

CFX Traffic Data and Statistics Manual 2018



Table of Contents



2018 Traffic Data and Statistics Manual
CENTRAL FLORIDA EXPRESSWAY AUTHORITY

TABLE OF CONTENTS

Executive Summary i

SECTION I - SYSTEM MAPS

Central Florida Expressway System 1

Toll Plaza Location Map 2

SECTION II - TRAFFIC COUNTS

Traffic Counts Introduction 3

2018 AAWT Segment & Mainline Plaza Volumes 4

SR 408 (East-West Expressway) Mainline Volume Summary 6

SR 408 (East-West Expressway) Interchange-Ramp Volume Summary 7

SR 528 (Beachline Expressway) Mainline Volume Summary 13

SR 528 (Beachline Expressway) Interchange-Ramp Volume Summary 14

SR 417 (Central Florida GreeneWay) Mainline Volume Summary 18

SR 417 (Central Florida GreeneWay) Interchange-Ramp Volume Summary 19

SR 429 (Western Beltway and Wekiva Parkway) Mainline Volume Summary 24

SR 429 (Western Beltway and Wekiva Parkway) Interchange-Ramp Volume Summary 25

SR 414 (Apopka Expressway) Mainline Volume Summary 29

SR 414 (Apopka Expressway) Interchange-Ramp Volume Summary 30

SR 451 (Western Beltway Connector Road) Mainline Volume Summary 32

SR 451 (Western Beltway Connector Road) Ramp Volume Summary 33

SR 453 Mainline Volume Summary 35

SR 453 Ramp Volume Summary	36
Weekday, Daily and Monthly Adjustment Factors	38

SECTION III – MAINLINE TOLL FACILITY CHARACTERISTICS

Mainline Toll Facility Characteristics Introduction	42
Hiwassee Mainline Toll Facility - SR 408	44
Pine Hills Mainline Toll Facility - SR 408	54
Conway East & West Mainline Toll Facility - SR 408	64
Dean Mainline Toll Facility - SR 408	75
Beachline Mainline Toll Facility - SR 528	85
Dallas Mainline Toll Facility - SR 528	95
John Young Mainline Toll Facility - SR 417	105
Boggy Creek Mainline Toll Facility - SR 417	115
Curry Ford Mainline Toll Facility - SR 417	125
University Mainline Toll Facility - SR 417	135
Independence Mainline Toll Facility - SR 429	145
Forest Lake Mainline Toll Facility - SR 429	155
Coral Hills Mainline Toll Facility - SR 414	165
Ponkan Mainline Toll Gantry - SR 429	175
Mount Plymouth Mainline Toll Gantry - SR 429	185
Coronado Mainline Toll Gantry - SR 453	195
Goldenrod Mainline Toll Facility - SR 551	205

SECTION IV - INTERCHANGES

SR 408 (East-West Expressway) Interchanges	215
SR 50 Spur - Exit 1	216
Good Homes Road - Exit 2	217
Hiawassee Road - Exit 4	218
Kirkman Road - Exit 5	219
Pine Hills Road - Exit 6	220
Old Winter Garden Road/Ortman Road - Exit 7	221
John Young Parkway - Exit 8A	222
Tampa Avenue - Exit 8B	223
Orange Blossom Trail - Exit 9	224
Interstate 4 - Exit 10A	225
Orange Avenue (1) - Entrance	226
Orange Avenue (2) - Exit 10B	227
Rosalind Avenue - Exit 11A	228
Mills Avenue - Exit 11B	229
Bumby Avenue - Exit 12A	230
Crystal Lake Drive - Exit 12B	231
Conway Road - Exit 13	232
Andes Avenue/Semoran Boulevard (SR 436) - Exit 14	233
Semoran Boulevard (SR 436) - Exit 14	234
Yucatan Drive - Entrance	235
Goldenrod Road (SR 551) - Exit 16	236
Chickasaw Trail - Exit 17	237
Central Florida GreeneWay (SR 417) - Exit 18	238
Dean Road - Exit 19	239
Rouse Road - Exit 20	240
Alafaya Trail - Exit 21	241
East Colonial Drive (SR 50) - Exit 23	242
SR 528 (Beachline Expressway) Interchanges	244
Boggy Creek Road - Exit 8	245
Tradeport Drive/Conway Road - Exit 9	247
Semoran Boulevard (SR 436) - Exit 11A & B	248
Goldenrod Road (SR 551) - Exit 12	249
Narcoossee Road (CR 15) - Exit 13	250

Central Florida GreeneWay (SR 417) - Exit 16	251
Innovation Way - Exit 19	252
Dallas Boulevard - Exit 24	253
SR 520 - Exit 31	254
SR 417 (Central Florida GreeneWay) Interchanges	257
International Drive - Exit 6	258
John Young Parkway - Exit 10	259
US 17-92/US 441/Orange Blossom Trail - Exit 11	260
Florida's Turnpike - Exit 12	261
Landstar Boulevard - Exit 14	262
South Access Road/International Airport/Boggy Creek Road - Exit 17A & B (1)	263
South Access Road/International Airport/Boggy Creek Road - Exit 17A & B (2)	264
Lake Nona Boulevard - Exit 19	265
Narcoossee Road (CR 15) - Exit 22	266
Moss Park Road - Exit 23	267
Dowden Road - Exit 24	268
Beachline Expressway (SR 528) - Exit 26	269
Lee Vista Boulevard - Exit 27	270
Curry Ford Road - Exit 30	271
East-West Expressway (SR 408) - Exit 33A & B	272
East Colonial Drive (SR 50) - Exit 34	273
University Boulevard - Exit 37A & B	274
NB SR 417 Exit to University Boulevard - Exit 37A	275
SR 429 (Western Beltway and Wekiva Parkway) Interchanges	277
Schofield Road - Exit 13	278
New Independence Parkway - Exit 15	279
CR 535 - Exit 19	280
Florida's Turnpike/West Colonial Drive (SR 50) - Exit 22/23	281
Plant Street/Franklin Street (SR 438) - Exit 24	282
Plant Street/Franklin Street (SR 438) - Exit 24	283
West Road/Clarcona-Ocoee Road - Exit 26	284
Ocoee-Apopka Road (CR 437A) - Exit 29	285
Apopka Expressway (SR 414) - Exit 30	286
SR 429/SR 414 at US 441/Connector Road/CR 437 - Exit 34	287

Kelly Park Road - Exit 38	288
Wekiva Parkway (SR 453) - Exit 39	289
SR 414 (Apopka Expressway) Interchanges	291
SR 451 - Exit 4A	292
Western Beltway (SR 429) - Exit 4B	293
Marden Road - Exit 5	294
Keene Road - Exit 6	295
Hiawassee Road - Exit 8	296
Orange Blossom Trail (US 441) - Exit 9	297
SR 451 (Western Beltway Connector Road) Interchanges	299
SR 414 East/SR 429 South - Exit 4A/4B	300
Orange Blossom Trail (US 441) - Exit 33	301
SR 453 Interchanges	303
SR 429 (Western Beltway and Wekiva Parkway) - Exit 39	304
SR 453 at SR 46 - Exit 3	305

SECTION V - GENERAL STATISTICS

General Statistics Introduction	306
Expressway Mileage and Total Lane Miles	308
Toll Facilities Lane Summary	309
Toll Rate Schedule	312
Distance Between Interchanges	315
SR 408 Distance Between Interchanges	316
SR 528 Distance Between Interchanges	321
SR 417 Distance Between Interchanges	322
SR 429 Distance Between Interchanges	326
SR 451 Distance Between Interchanges	328
SR 414 Distance Between Interchanges	329
SR 451 Distance Between Interchanges	330
SR 453 Distance Between Interchanges	331
Toll Rates Between Interchanges	332

SR 408 Toll Rates Between Interchanges	333
SR 528 Toll Rates Between Interchanges	338
SR 417 Toll Rates Between Interchanges	339
SR 429 Toll Rates Between Interchanges	343
SR 414 Toll Rates Between Interchanges	346
SR 453 Toll Rates Between Interchanges	347
Cost per Mile Between Interchanges	348
SR 408 Cost per Mile Between Interchanges	349
SR 528 Cost per Mile Between Interchanges	354
SR 417 Cost per Mile Between Interchanges	355
SR 429 Cost per Mile Between Interchanges	359
SR 414 Cost per Mile Between Interchanges	362
SR 453 Cost per Mile Between Interchanges	363

Executive Summary

The Central Florida Expressway Authority (CFX) system includes 118 centerline miles, 815 lane miles (including ramps), 69 interchanges, 335 bridges and 17 mainline toll facilities. CFX's system includes SR 408 (Spessard L. Holland Expressway and Arnold Palmer Expressway), SR 528 (Martin Andersen Beachline Expressway), SR 417 (Central Florida GreeneWay), SR 429 (Daniel Webster Western Beltway and Wekiva Parkway), SR 414 (John Land Apopka Expressway), SR 451 and SR 453.

“To provide the region with a world-class, integrated mobility network that drives economic prosperity and quality of life”

Vision Statement

On average, over a million toll transactions are recorded every day. CFX is authorized to build, operate and maintain a transportation facility in Central Florida, incorporating Lake, Orange, Seminole, Osceola and Brevard counties. This five-county region has more than 3 million residents and over 68 million visitors annually.

Towards the goal of a world-class system, and the strategic priority to build a customer-driven organization, CFX prepares this manual to provide a complete set of data relating to traffic volumes, traffic characteristics, toll facility operations and interchange lane configurations for their system. This data is utilized to project traffic trends and identify future capacity improvement projects within the system that can then be included into the Five-Year Work Plan.

For the fiscal year 2018, overall traffic increased on the system by 8.3%. Mainline volume changes range from -3.6% to 76.8%. This large increase is due to the opening of Wekiva Parkway Phase II. Of particular interest are the segments of roadways at the ends of the spectrum:

- SR 408 (Interstate 4 to Alafaya Trail) average growth of less than 1%
- SR 417 (International Drive to Landstar Boulevard) over 7% growth
- SR 417 (South Access (OIA) / Boggy Creek Road to Lake Nona Boulevard) 12% growth
- SR 429 (Seidel Road to CR 535) over 16% growth
- SR 429 (SR 414 o Kelly Park Road) over 33% growth

The data collected and detailed in this report is a snapshot in time. It should be noted that this data varies with time due to a number of influences. Factors such as construction and weather

can affect the routes that drivers choose to travel. Some of the activities controlled by CFX that may influence traffic data include:

- Expansion Projects
 - SR 429 (Wekiva Parkway Phase II)
 - SR 453
- Existing System Capacity Improvements (Complete and Under construction)
 - 253G - SR 408 / SR 417 Interchange Improvements Phase II
 - 408-128 - Widening SR 408 from SR 417 to Alafaya Trail
 - 417-134 - Widening SR 417 from North of E4 Canal to Aloma Avenue
- New and/or Modified Interchanges
 - SR 408 / Interstate 4 Ultimate Interchange (In partnership with others)
 - 528-313 - SR 528 / Innovation Way Interchange
 - SR 417 / Florida's Turnpike Interchange Improvements (By others)

The data collected in April 2018 and October 2018 is summarized in the following sections.

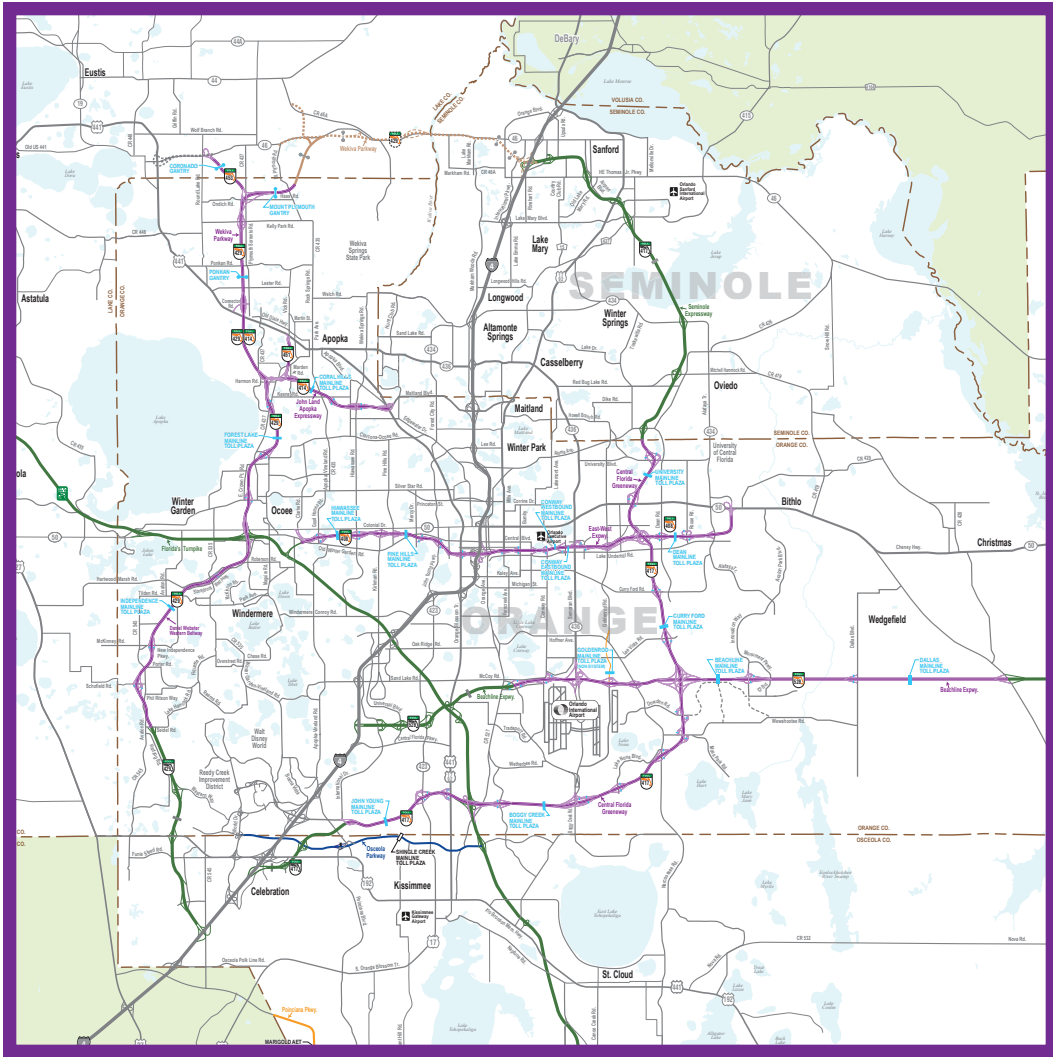

Section I: System Maps

2018 Traffic Data and Statistics Manual
CENTRAL FLORIDA EXPRESSWAY AUTHORITY

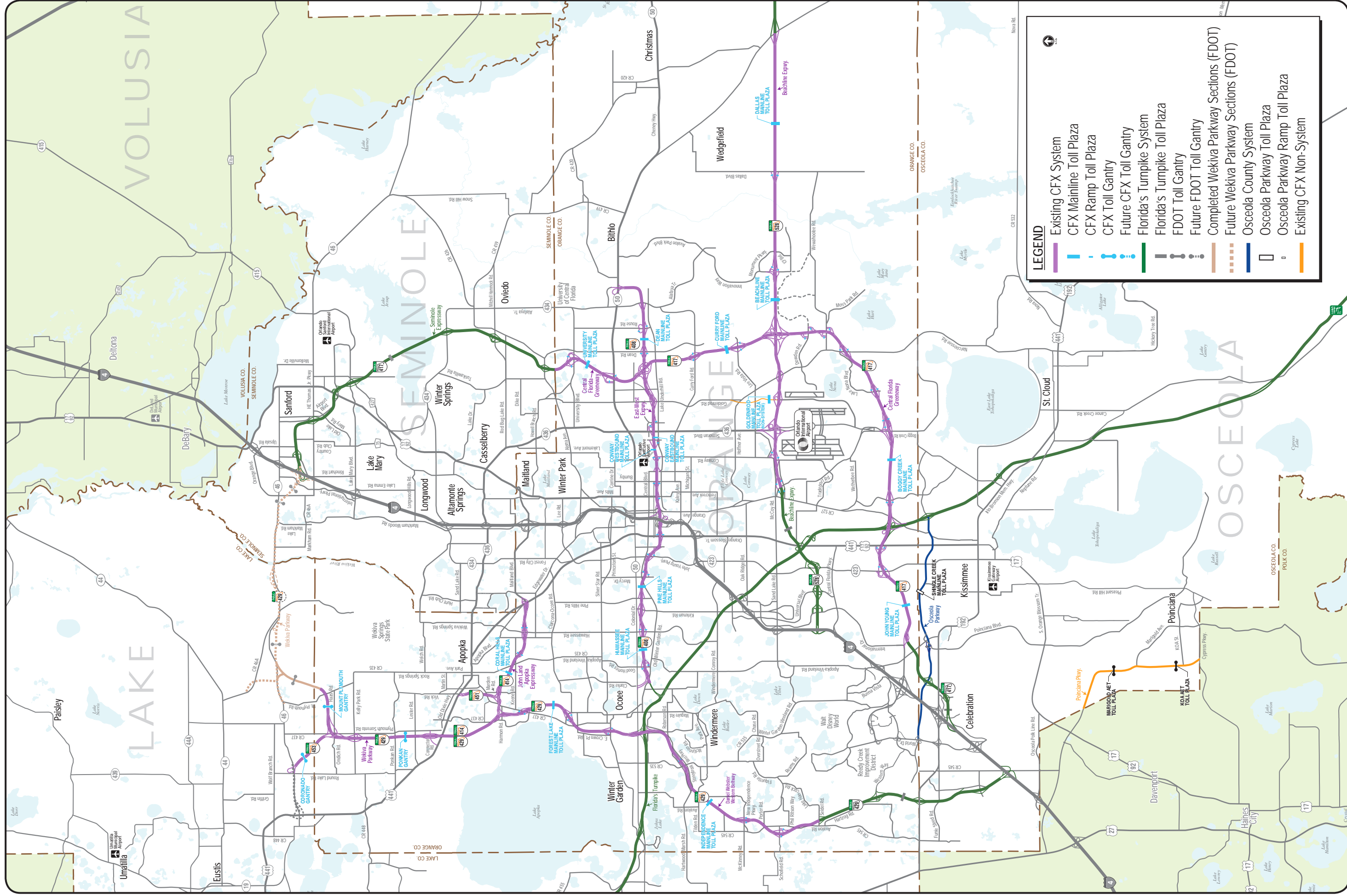

LEGEND

- Existing CFX System
- CFX Mainline Toll Plaza
- CFX Ramp Toll Plaza
- CFX Toll Gantry
- Future CFX Toll Gantry
- Florida's Turnpike System
- Florida's Turnpike Toll Plaza
- FDOT Toll Gantry
- Future FDOT Toll Gantry
- Completed Wekiva Parkway Sections (FDOT)
- Future Wekiva Parkway Sections (FDOT)
- Osceola County System
- Osceola Parkway Toll Plaza
- Osceola Parkway Ramp Toll Plaza
- Existing CFX Non-System

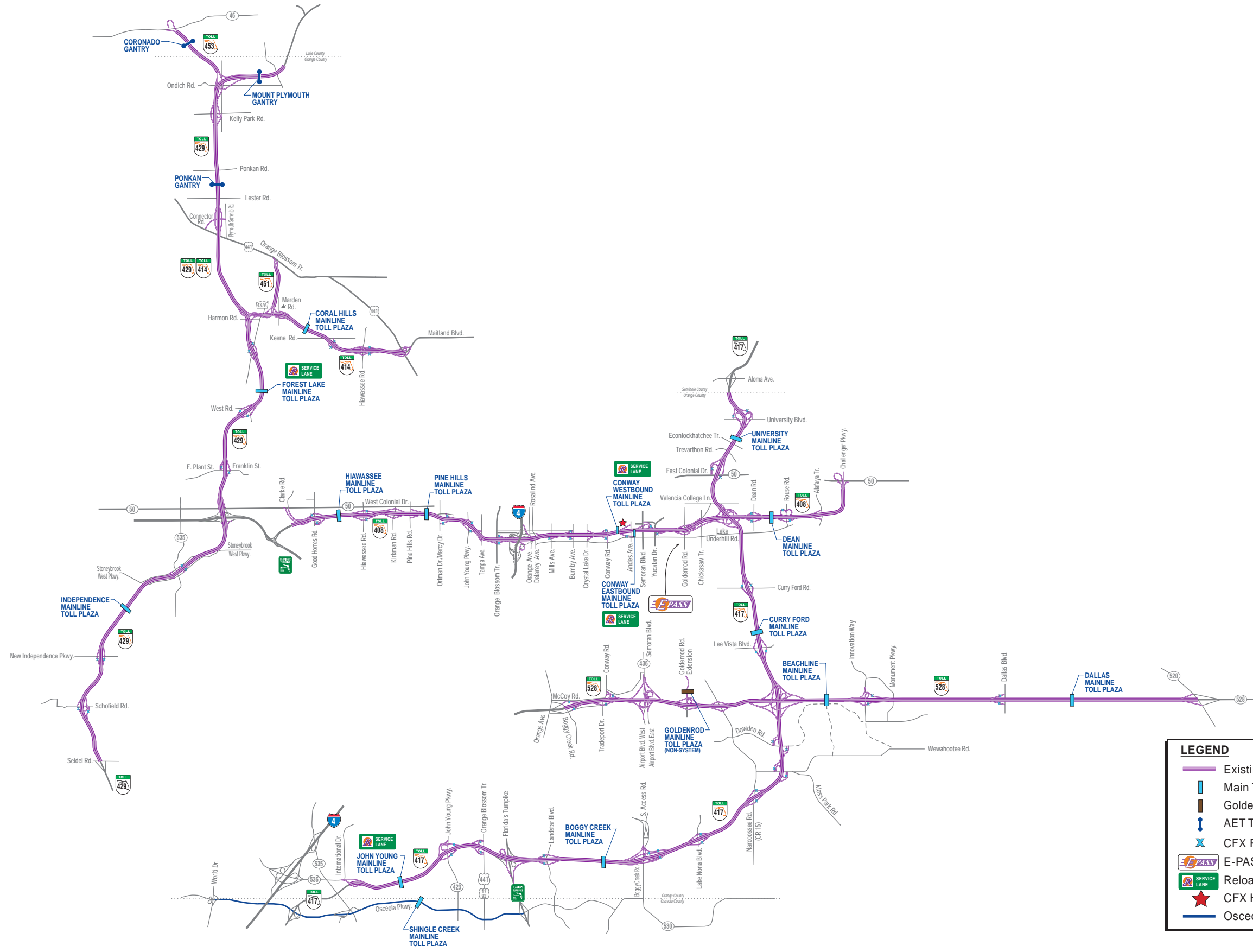

LEGEND

- Existing CFX System
- Main Toll Plaza
- Goldenrod Toll Facility (non-system)
- AET Toll Gantry
- CFX Ramp Toll Plaza
- E-PASS Service Center
- Reload E-PASS Service Lane
- CFX Headquarters
- Osceola Parkway

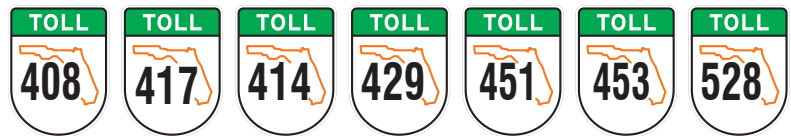

TOLL PLAZA LOCATION MAP CFX Expressway System



Section II: Traffic Counts

2018 Traffic Data and Statistics Manual
CENTRAL FLORIDA EXPRESSWAY AUTHORITY

Traffic Counts Introduction

Traffic data was collected Monday thru Friday for the entire month of April 2018 utilizing the Wavetronics Data Collection Sensors (SS125 HD) recently installed throughout the CFX system. Traffic data was also collected for the entire month of October 2018 utilizing the Wavetronics Data Collection Sensors (SS125 HD), and Toll Plaza data was collected for the entire month of April 2018.

Traffic data collected at the ramp and mainline toll plazas for the same five days is also utilized to calculate the Average Annual Weekday Traffic (AAWT). The data collection for this manual was completed during the month of April 2018 at the appropriate interchange ramp and mainline locations.

Monthly adjustment factors used to convert 24-hour weekday traffic counts to AAWT, are presented for each mainline segment and their accompanying ramps. These factors are based on the daily transaction information received from CFX for the mainline toll plazas' monthly transaction records for the most recent year unaffected by toll adjustments and major system additions. For example, if a 24-hour roadway count is collected on a normal weekday in April at a certain location, then that count would be multiplied by the appropriate monthly (April) factor to convert it to an average annual weekday volume. This normalizes the variations in weekly and monthly traffic so that counts taken at different times in the year can be compared.

The following pages contain estimates of AAWT for all mainline sections, and ramps associated with the CFX system facilities. The data includes the most recent observations, as well as historical traffic volumes starting from the year 2008 (where applicable).

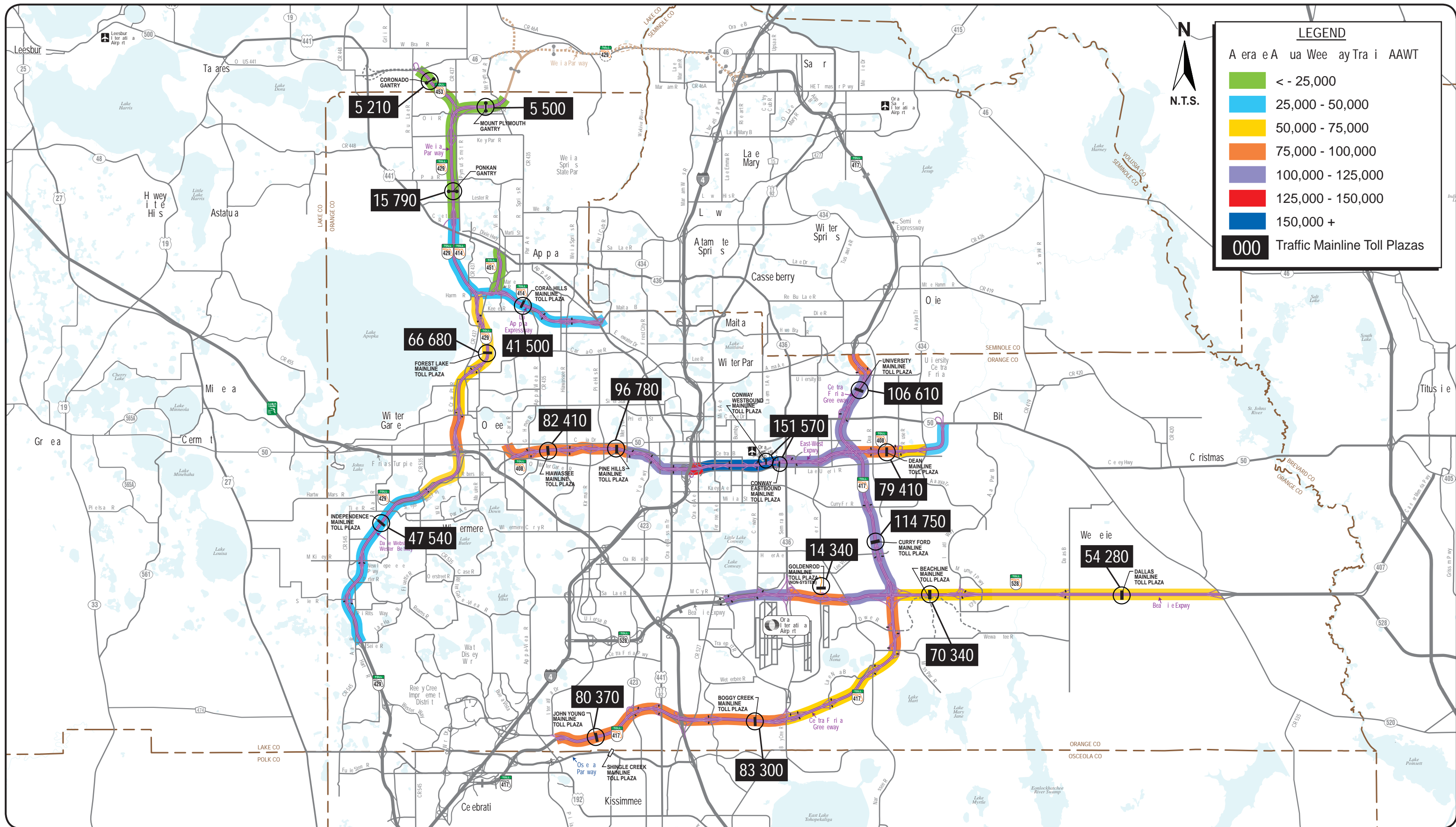

East-West Expressway



Existing and Historical Average Annual Weekday Mainline Traffic Volumes

Location	Year 2008	Year 2009	Year 2010	Year 2011	Year 2012	Year 2013	Year 2014	Year 2015	Year 2016	Year 2017	Year 2018
Florida Turnpike to SR 50 Spur / Clarke Road	46,980	42,220	42,740	44,580	44,130	46,360	50,710	57,450	62,830	68,380	73,020
SR 50 Spur / Clarke Road to Good Homes Road	58,890	53,740	54,560	55,030	53,930	56,070	60,500	68,170	73,650	78,140	83,410
Good Homes Road to Hiwassee Road	61,560	55,900	56,680	57,170	56,330	57,750	61,440	69,490	73,510	77,260	82,410
Hiwassee Road to Kirkman Road	67,950	60,950	62,250	62,410	60,960	62,410	66,730	73,490	76,680	81,550	86,090
Kirkman Road to Pine Hills Road	71,650	64,690	65,860	66,770	65,970	66,710	71,580	78,780	81,440	84,970	89,910
Pine Hills Road to Old Winter Garden Road	77,780	69,800	71,150	72,070	71,190	72,020	77,210	85,210	89,080	92,690	96,780
Old Winter Garden Road to John Young Parkway	81,790	73,190	74,880	75,820	74,850	76,310	81,130	90,450	94,740	98,820	103,290
John Young Parkway to Tampa Avenue	83,380	74,660	76,850	77,910	77,060	78,730	83,890	93,600	97,370	101,430	109,390
Tampa Avenue to US 441 (Orange Blossom Trail)	81,140	72,660	74,930	76,000	75,200	76,940	81,830	91,110	93,780	98,310	104,010
US 441 (Orange Blossom Trail) to Interstate 4 (I-4)	82,050	74,065	76,870	77,480	76,990	79,710	84,860	93,810	96,210	102,400	101,720
Interstate 4 (I-4) to Rosalind Avenue	100,810	108,040	112,550	116,620	113,060	114,050	118,820	127,860	135,130	138,600	141,330
Rosalind Avenue to Mills Avenue	119,820	126,480	130,650	134,260	131,970	132,930	139,470	152,210	157,830	160,300	162,090
Mills Avenue to Bumby Avenue	131,040	133,680	139,600	143,050	140,210	141,140	147,810	160,220	166,820	168,710	172,540
Bumby Avenue to Crystal Lake Drive	119,590	122,430	128,130	131,380	128,970	128,590	135,300	146,110	152,210	154,830	156,080
Crystal Lake Drive to Conway Road	132,850	132,200	138,930	141,490	138,810	136,320	144,420	157,950	165,780	169,430	172,110
Conway Road to Andes Avenue	120,130	120,900	127,020	129,090	127,170	125,460	132,760	144,880	152,970	156,110	153,570
Andes Avenue to SR 436 / Yucatan Drive	112,240	112,750	117,830	119,600	117,530	115,530	122,400	132,940	140,380	143,970	148,140
SR 436 / Yucatan Drive to Goldenrod Rd/Chickasaw Trail	110,690	111,380	115,600	116,310	114,450	116,930	123,510	131,920	139,480	141,600	148,300
Goldenrod Rd/Chickasaw Trail to SR 417 (Central FL GreeneWay)	104,150	104,230	109,580	107,280	102,280	103,730	109,630	117,270	124,240	125,510	127,410
SR 417 (Central FL GreeneWay) to Dean Road	75,540	74,290	77,070	76,040	76,500	75,280	78,960	84,230	89,950	90,340	87,130
Dean Road to Rouse Road	65,990	65,900	68,130	66,670	67,200	67,320	71,110	74,180	79,580	80,340	79,410
Rouse Road to Alafaya Trail	59,670	59,650	61,080	59,680	59,850	59,150	64,030	66,260	69,410	70,630	70,100
Alafaya Trail to SR 50 (East Colonial Drive)	31,120	32,530	33,300	33,340	33,060	33,990	34,780	37,460	38,440	40,980	41,560

Notes:

1. SR 408 under construction in Years 2006-2011 from Interstate 4 (I-4) to Goldenrod Rd/Chickasaw Trail.
2. SR 408 under construction in Years 2015-2017 at the Interstate 4 (I-4) Interchange (I-4 Ultimate). Orange Avenue WB On Ramp closed in Years 2016-2018.
3. SR 408 under construction from Good Homes Road to Hiwassee Road in Years 2017-2018.
4. SR 408 / SR 417 Interchange under construction by projects 408-253 F/G.
5. SR 408 under construction from SR 417 to Alafaya Trail in Years 2017-2018.



SR 408 (EAST-WEST EXPRESSWAY) Mainline Volume Summary

SECTION II

6

Existing and Historical Average Annual Weekday Ramp Terminal Traffic Volumes

Ramp Location	Year 2008	Year 2009	Year 2010	Year 2011	Year 2012	Year 2013	Year 2014	Year 2015	Year 2016	Year 2017	Year 2018
Exit 1 : SR 50 / Clarke Road Spur											
Eastbound On-Ramp	6,150	6,040	6,220	5,640	5,310	5,050	5,510	5,600	5,580	4,930	5,740
Westbound Off-Ramp	5,760	5,480	5,600	4,810	4,490	4,330	4,450	4,840	4,670	4,510	5,040
Exit 2: Good Homes Road											
Eastbound Off-Ramp	2,950	2,840	3,150	3,430	3,430	3,690	4,010	4,630	5,300	5,660	6,310
Westbound On-Ramp	2,830	3,090	3,440	3,540	3,640	3,940	4,320	4,940	5,720	6,440	7,270
Eastbound On-Ramp	4,330	4,070	4,350	4,540	4,820	4,500	4,840	5,480	5,850	5,520	6,320
Westbound Off-Ramp	4,120	4,020	4,360	4,570	4,650	4,320	4,620	5,230	5,590	5,450	6,080
Exit 4 : Hiwassee Road											
Eastbound Off-Ramp	2,770	2,310	2,440	2,360	2,310	2,330	2,630	2,960	3,250	2,260	3,860
Westbound On-Ramp	2,910	2,420	2,430	2,330	2,160	2,240	2,550	2,960	3,350	3,720	4,480
Eastbound On-Ramp	6,340	5,220	5,550	5,310	4,810	4,920	5,410	5,990	6,190	6,280	6,800
Westbound Off-Ramp	5,730	4,560	4,890	4,620	4,290	4,270	4,780	5,000	5,210	5,740	6,030
Exit 5 : Kirkman Road											
Eastbound Off-Ramp	4,270	3,530	3,820	3,440	3,370	3,330	3,690	3,570	4,020	4,430	5,600
Westbound On-Ramp	4,010	3,370	3,950	3,190	3,110	3,210	3,510	3,720	4,220	4,480	5,310
Eastbound On-Ramp	6,110	5,560	6,090	5,900	6,170	7,740	6,180	6,760	6,770	6,640	7,110
Westbound Off-Ramp	5,870	5,080	5,290	5,090	5,320	6,550	5,440	5,840	6,140	5,870	7,220
Exit 6 : Pine Hills Road											
Eastbound On-Ramp	3,200	2,740	2,850	2,900	2,950	2,760	2,990	3,390	3,650	3,600	3,780
Westbound Off-Ramp	2,930	2,370	2,440	2,400	2,270	2,550	2,620	2,080	2,300	1,840	3,570

Notes:

1. SR 408 under construction in Years 2006-2011 from Interstate 4 (I-4) to Goldenrod Rd/Chickasaw Trail.
2. SR 408 under construction in Years 2015-2017 at the Interstate 4 (I-4) Interchange (I-4 Ultimate). Orange Avenue WB On Ramp closed in Years 2016-2018.
3. SR 408 under construction from Good Homes Road to Hiwassee Road in Years 2017-2018.
4. SR 408 / SR 417 Interchange under construction by projects 408-253 F/G.
5. SR 408 under construction from SR 417 to Alafaya Trail in Years 2017-2018.



SR 408 (EAST-WEST EXPRESSWAY) Interchange - Ramp Volume Summary

Existing and Historical Average Annual Weekday Ramp Terminal Traffic Volumes

Ramp Location	Year 2008	Year 2009	Year 2010	Year 2011	Year 2012	Year 2013	Year 2014	Year 2015	Year 2016	Year 2017	Year 2018
Exit 7 : Old Winter Garden Road											
Eastbound On-Ramp	1,870	1,600	1,750	1,770	1,750	1,880	2,130	2,230	2,490	2,690	3,120
Westbound Off-Ramp	2,140	1,790	1,980	1,980	1,910	2,050	2,280	2,540	2,790	3,060	3,210
Exit 8A : John Young Parkway											
Eastbound Off-Ramp	4,360	3,440	3,660	3,810	3,920	3,110	3,220	3,680	3,850	3,910	4,630
Westbound On-Ramp	4,130	3,940	3,760	3,590	3,620	3,420	3,740	4,320	4,700	4,630	5,100
Eastbound On-Ramp	5,340	4,130	5,020	5,270	5,540	5,310	5,680	6,660	6,740	6,800	7,290
Westbound Off-Ramp	4,740	4,720	4,370	4,220	4,210	4,240	4,320	4,690	4,700	4,850	5,490
Exit 8B : Tampa Avenue											
Eastbound Off-Ramp	1,080	990	930	970	870	880	1,030	1,210	1,660	1,900	2,420
Westbound On-Ramp	1,160	1,010	990	940	990	1,040	1,140	1,300	1,810	1,880	2,320
Exit 9 : Orange Blossom Trail (US 441)											
Eastbound Off-Ramp	3,090	2,660	2,610	2,690	2,600	2,570	2,770	3,130	3,690	3,720	3,980
Westbound On-Ramp	3,300	2,740	2,770	2,850	2,650	2,690	2,930	3,170	3,870	3,520	5,070
Eastbound On-Ramp	3,720	3,400	3,720	3,690	3,640	3,970	4,280	4,660	5,170	5,580	6,520
Westbound Off-Ramp	3,580	3,405	3,600	3,330	3,400	3,690	3,920	4,160	4,530	5,140	6,230
Exit 10A/B : Interstate 4											
SR 408 Eastbound Off-Ramp to WB I-4	3,640	3,535	3,400	3,300	3,160	2,470	3,390	3,330	3,270	3,840	4,660
SR 408 Eastbound Off-Ramp to EB I-4	9,090	7,980	8,020	7,920	7,940	7,510	7,640	7,440	7,240	8,580	11,620
SR 408 Westbound On-Ramp from I-4	11,590	8,685	8,070	8,040	7,560	7,340	8,280	9,205	10,130	9,320	11,650
SR 408 Eastbound On-Ramp from I-4	30,910	31,650	31,560	23,920	30,890	29,950	33,780	36,185	38,590	28,400	31,430

Notes:

1. SR 408 under construction in Years 2006-2011 from Interstate 4 (I-4) to Goldenrod Rd/Chickasaw Trail.
2. SR 408 under construction in Years 2015-2017 at the Interstate 4 (I-4) Interchange (I-4 Ultimate). Orange Avenue WB On Ramp closed in Years 2016-2018.
3. SR 408 under construction from Good Homes Road to Hiwassee Road in Years 2017-2018.
4. SR 408 / SR 417 Interchange under construction by projects 408-253 F/G.
5. SR 408 under construction from SR 417 to Alafaya Trail in Years 2017-2018.



SR 408 (EAST-WEST EXPRESSWAY) Interchange - Ramp Volume Summary

Existing and Historical Average Annual Weekday Ramp Terminal Traffic Volumes

Ramp Location	Year 2008	Year 2009	Year 2010	Year 2011	Year 2012	Year 2013	Year 2014	Year 2015	Year 2016	Year 2017	Year 2018
Exit 10A/B : Interstate 4 (continued)											
SR 408 Westbound Off-Ramp to WB I-4	20,660	23,510	22,830	22,790	22,900	21,490	21,630	22,020	22,410	18,170	23,960
SR 408 Westbound Off-Ramp to EB I-4	6,370	13,655	15,000	14,510	14,730	14,080	12,990	10,770	8,550	10,990	14,630
Interstate 4 Westbound Off-Ramp	21,140	21,080	19,770	16,300	22,830	22,140	25,740	28,140	30,540	25,530	27,940
Interstate 4 Westbound On-Ramp	24,300	26,420	26,230	26,090	26,060	23,960	25,020	25,350	25,680	24,680	28,620
Interstate 4 Eastbound Off-Ramp to SR 408	21,360	18,410	19,860	15,660	15,620	15,150	16,320	17,250	18,180	16,180	15,140
Exit 10C : Orange Avenue											
Eastbound Off-Ramp	13,200	9,530	7,100	6,890	6,930	6,800	6,820	7,320	7,270	7,530	8,060
Westbound On-Ramp	5,730	5,110	5,470	5,500	5,500	5,430	5,720	6,520	-----	-----	-----
Exit 11A : Rosalind Avenue											
Eastbound On-Ramp	9,790	8,670	9,190	9,540	10,200	9,280	9,830	12,090	11,670	12,390	12,890
Westbound Off-Ramp	9,220	9,770	8,910	8,100	8,710	9,640	10,340	10,850	6,190	10,250	11,070
Exit 11B : Mills Avenue											
Eastbound Off-Ramp	1,250	1,070	1,100	1,050	1,080	1,080	1,200	1,430	1,570	1,610	1,750
Eastbound On-Ramp	8,370	4,050	4,300	4,280	4,300	4,510	5,300	5,590	6,250	6,160	7,310
Westbound Off-Ramp	4,100	4,220	5,750	5,560	5,020	4,070	4,260	4,420	4,820	5,370	5,240
Exit 12A : Bumby Avenue											
Eastbound Off-Ramp	5,470	5,420	5,330	5,460	5,330	5,180	5,580	6,300	6,380	6,800	7,470
Westbound On-Ramp	5,980	5,830	6,140	6,210	5,910	5,890	6,580	7,280	7,780	8,230	9,140
Exit 12B : Crystal Lake Drive											
Eastbound On-Ramp	8,110	4,660	5,580	5,130	4,910	4,920	5,590	5,890	6,530	6,800	7,700
Westbound Off-Ramp	5,150	5,110	5,220	4,980	4,930	5,600	6,210	6,760	7,330	8,010	9,190

Notes:

1. SR 408 under construction in Years 2006-2011 from Interstate 4 (I-4) to Goldenrod Rd/Chickasaw Trail.
2. SR 408 under construction in Years 2015-2017 at the Interstate 4 (I-4) Interchange (I-4 Ultimate). Orange Avenue WB On Ramp closed in Years 2016-2018.
3. SR 408 under construction from Good Homes Road to Hiwassee Road in Years 2017-2018.
4. SR 408 / SR 417 Interchange under construction by projects 408-253 F/G.
5. SR 408 under construction from SR 417 to Alafaya Trail in Years 2017-2018.



SR 408 (EAST-WEST EXPRESSWAY) Interchange - Ramp Volume Summary

Existing and Historical Average Annual Weekday Ramp Terminal Traffic Volumes

Ramp Location	Year 2008	Year 2009	Year 2010	Year 2011	Year 2012	Year 2013	Year 2014	Year 2015	Year 2016	Year 2017	Year 2018
Exit 13 : Conway Road											
Eastbound Off-Ramp	5,880	5,120	5,530	5,730	5,430	5,180	5,470	5,990	6,270	6,350	6,870
Westbound On-Ramp	6,840	6,180	6,380	6,670	6,210	5,680	6,190	6,280	6,680	7,010	7,310
Exit 14 : SR 436 / Andes Ave											
Eastbound Off-Ramp to Andes Ave / SR 436	7,890	7,700	8,780	9,010	9,170	9,440	9,950	11,030	11,650	11,570	11,650
Westbound On-Ramp from SR 436 SB	5,210	4,790	5,240	5,410	5,350	5,450	5,870	6,790	7,270	6,810	7,290
Westbound On-Ramp from SR 436 NB	4,670	4,920	5,670	6,130	5,620	5,430	5,690	6,480	6,650	6,760	7,110
Eastbound On-Ramp from Yucatan Dr	4,580	4,420	4,380	3,950	3,920	4,230	4,540	4,990	5,320	5,330	5,690
Westbound Off-Ramp to SR 436	3,750	3,920	4,300	4,300	3,970	4,510	5,030	5,600	5,860	5,870	6,640
Westbound On-Ramp from Andes Ave	----	450	410	480	470	490	410	580	680	810	910
Exit 16 : Goldenrod Road (SR 551)											
Eastbound Off-Ramp	9,970	9,480	10,240	10,480	10,660	7,310	7,510	8,160	6,190	8,190	8,350
Westbound On-Ramp	9,620	9,570	10,110	10,060	11,040	6,800	7,210	7,570	7,770	7,720	7,810
Eastbound On-Ramp	6,680	6,060	6,930	5,790	4,580	4,900	5,510	6,040	6,570	6,340	6,590
Westbound Off-Ramp	6,370	5,840	7,400	5,720	4,950	5,370	5,570	6,210	6,550	7,580	6,780
Exit 17 : Chickasaw Trail											
Eastbound Off-Ramp	----	----	----	----	----	4,850	5,510	5,700	6,610	6,720	7,170
Westbound On-Ramp	----	----	----	----	----	4,320	4,750	5,550	6,440	7,580	7,250
Exit 18 : SR 417 (Central Florida GreeneWay)											
Eastbound Off-Ramp to SB SR 417	6,400	6,700	7,080	6,950	7,310	7,530	8,620	9,880	11,040	10,690	14,230
Eastbound Off-Ramp to NB SR 417	-----	-----	-----	-----	15,090	15,450	16,160	17,540	18,470	18,730	19,740
Westbound On-Ramp from NB SR 417	6,920	7,100	7,530	8,050	8,170	8,190	8,180	10,520	11,910	11,350	14,920

Notes:

1. SR 408 under construction in Years 2006-2011 from Interstate 4 (I-4) to Goldenrod Rd/Chickasaw Trail.
2. SR 408 under construction in Years 2015-2017 at the Interstate 4 (I-4) Interchange (I-4 Ultimate). Orange Avenue WB On Ramp closed in Years 2016-2018.
3. SR 408 under construction from Good Homes Road to Hiwassee Road in Years 2017-2018.
4. SR 408 / SR 417 Interchange under construction by projects 408-253 F/G.
5. SR 408 under construction from SR 417 to Alafaya Trail in Years 2017-2018.



SR 408 (EAST-WEST EXPRESSWAY) Interchange - Ramp Volume Summary

SECTION II

10

Existing and Historical Average Annual Weekday Ramp Terminal Traffic Volumes

Ramp Location	Year 2008	Year 2009	Year 2010	Year 2011	Year 2012	Year 2013	Year 2014	Year 2015	Year 2016	Year 2017	Year 2018
Exit 18 : SR 417 (Central Florida GreeneWay) (cont.)											
Westbound On-Ramp from SB SR 417	-----	-----	-----	15,980	15,290	15,590	15,980	16,970	18,080	18,450	19,810
Eastbound On-Ramp from NB SR 417	7,210	6,080	6,220	6,230	6,340	6,040	6,030	7,230	7,660	8,180	9,820
Eastbound On-Ramp from SB SR 417	5,960	3,645	3,620	3,900	3,480	3,430	3,740	4,000	4,590	4,790	5,320
Westbound Off-Ramp to NB SR 417	4,130	3,975	4,220	4,020	3,410	3,590	3,870	4,250	4,770	4,920	5,040
Westbound Off-Ramp to SB SR 417	6,980	6,520	6,380	6,250	6,850	5,830	6,210	7,130	7,780	8,550	9,260
Exit 19 : Dean Road											
Eastbound Off-Ramp	5,660	4,960	5,220	5,390	5,560	5,300	4,870	5,490	5,940	5,990	6,530
Westbound On-Ramp	6,360	5,780	6,260	6,240	6,120	5,980	5,750	6,280	7,050	7,490	7,840
Eastbound On-Ramp	1,270	1,200	1,220	1,180	1,270	1,560	1,430	1,440	1,760	1,570	1,710
Westbound Off-Ramp	1,200	1,150	1,320	1,080	1,110	1,090	1,380	1,420	1,680	1,400	1,520
Exit 20 : Rouse Road											
Eastbound Off-Ramp	4,240	4,210	4,550	4,690	4,790	4,410	5,290	5,670	5,990	5,950	6,300
Westbound On-Ramp	3,800	3,530	3,950	3,590	3,720	3,730	4,400	4,800	5,750	5,330	5,640
Eastbound On-Ramp	890	760	710	660	610	670	730	740	830	710	910
Westbound Off-Ramp	830	730	740	630	550	550	650	720	760	680	940
Exit 21: Alafaya Trail											
Eastbound Off-Ramp	14,540	13,480	13,770	12,850	13,240	12,430	13,600	14,640	15,150	14,430	14,590
Westbound On-Ramp	14,010	13,640	14,010	13,490	13,550	12,730	14,660	15,330	16,000	15,520	15,560
Exit 23 : SR 50 (East Colonial Drive)											
Eastbound Off-Ramp	13,170	11,110	11,450	13,080	11,200	11,700	11,900	12,900	12,070	13,210	14,580
Westbound On-Ramp from EB SR 50	1,330	1,310	1,420	1,380	1,290	1,430	1,570	2,040	2,210	2,230	2,480
Westbound On Ramp from WB SR 50	10,680	10,480	11,770	10,410	10,300	9,930	9,970	10,890	10,360	12,250	13,290

Notes:

1. SR 408 under construction in Years 2006-2011 from Interstate 4 (I-4) to Goldenrod Rd/Chickasaw Trail.
2. SR 408 under construction in Years 2015-2017 at the Interstate 4 (I-4) Interchange (I-4 Ultimate). Orange Avenue WB On Ramp closed in Years 2016-2018.
3. SR 408 under construction from Good Homes Road to Hiawasse Road in Years 2017-2018.
4. SR 408 / SR 417 Interchange under construction by projects 408-253 F/G.
5. SR 408 under construction from SR 417 to Alafaya Trail in Years 2017-2018.



SR 408 (EAST-WEST EXPRESSWAY) Interchange - Ramp Volume Summary

Beachline Expressway



Existing and Historical Average Annual Weekday Mainline Traffic Volumes

Location	Year 2008	Year 2009	Year 2010	Year 2011	Year 2012	Year 2013	Year 2014	Year 2015	Year 2016	Year 2017	Year 2018
Boggy Creek Road to Tradeport Drive	85,700	85,340	88,765	90,780	94,310	92,200	98,510	104,530	110,540	109,140	112,350
Tradeport Drive to SR 436 (Semoran Boulevard)	76,260	75,200	77,840	78,680	80,840	80,730	83,820	91,280	98,740	109,020	112,970
SR 436 (Semoran Boulevard) to Goldenrod Road	67,780	64,245	64,450	67,700	68,610	71,910	73,760	79,710	85,770	93,500	99,040
Goldenrod Road to Narcoossee Road	68,070	65,670	65,350	68,710	69,920	73,700	75,190	81,920	89,020	97,000	102,750
Narcoossee Road to SR 417 (Central Florida GreeneWay)	55,610	53,280	54,080	55,910	54,280	58,270	60,730	65,110	70,470	76,630	81,000
SR 417 (Central Florida GreeneWay) to Innovation Way	42,450	43,300	46,300	46,880	48,430	49,230	53,510	56,120	60,710	64,640	70,340
Innovation Way to Dallas Boulevard	40,160	41,430	43,730	42,190	41,910	43,390	46,460	49,590	52,470	56,090	59,940
Dallas Boulevard to SR 520	35,650	37,910	39,580	38,730	38,360	39,190	40,890	45,530	46,880	50,590	54,280

Notes:

1. SR 528 under construction in the Years 2007-2008 at the SR 436 Interchange.
2. SR 528 under construction in the Years 2007-2008 at the Narcoossee Road Interchange.
3. SR 528 under construction in the Years 2008 - 2009 at the Beachline Main Mainline Toll Plaza.
4. SR 528 under construction in the Years 2010-2012 at Dallas Boulevard and the new Dallas Mainline Toll Plaza.
5. Systemwide Toll Increase was applied in July 2012 that included different toll rates for E-PASS and Cash customers.
6. SR 528 under construction in the Year 2013 for bridge deck replacements at Tradeport Drive, Daetwyler Drive and Via Flora Drive.
7. SR 528 under construction in the Year 2015 & 2016 widening and Airport Mainline Toll Plaza removal from Boggy Creek to SR 436.
8. SR 528 and Innovation Way interchange / ICP interchange removal under construction in Years 2017-2018.



SR 528 (BEACHLINE EXPRESSWAY) Mainline Volume Summary

Existing and Historical Average Annual Weekday Ramp Terminal Traffic Volumes

Ramp Location	Year 2008	Year 2009	Year 2010	Year 2011	Year 2012	Year 2013	Year 2014	Year 2015	Year 2016	Year 2017	Year 2018
Exit 8 : Boggy Creek Road											
Eastbound On-Ramp	15,730	14,530	15,320	16,000	15,350	11,790	12,710	11,990	11,260	11,540	11,670
Westbound Off-Ramp	13,160	11,450	11,730	12,030	12,080	10,960	11,570	10,610	9,650	10,400	10,490
Exit 9 : Tradeport Drive / Conway Road											
Eastbound Off-Ramp	9,930	9,110	9,490	9,910	10,680	9,180	9,670	9,820	9,970	4,430	5,020
Westbound On-Ramp	5,370	6,070	6,480	6,860	7,480	5,690	7,020	7,160	7,300	3,590	3,740
Eastbound On-Ramp	3,200	2,820	2,730	2,550	2,730	2,730	2,790	3,230	3,660	4,020	4,650
Westbound Off-Ramp	2,660	2,220	2,315	2,120	1,960	2,420	2,240	2,410	2,580	2,940	3,350
Exit 11 : SR 436 (Semoran Boulevard)											
Eastbound Off-Ramp to NB SR 436	4,890	5,250	4,740	4,580	4,960	4,740	3,440	5,560	6,870	7,280	7,300
Eastbound Off-Ramp to SB SR 436	10,840	13,220	13,850	11,720	14,200	13,010	14,830	16,150	17,600	18,120	18,170
Westbound On-Ramp from NB SR 436	10,880	12,770	13,040	13,440	13,130	11,970	11,780	14,310	14,580	16,160	16,350
Westbound On-Ramp from SB SR 436	6,220	6,225	7,110	6,590	6,350	6,080	6,110	6,520	6,930	8,130	8,380
Eastbound On-Ramp from NB SR 436	8,450	9,000	7,840	7,670	7,580	7,860	7,560	9,220	9,290	10,380	11,650
Eastbound On-Ramp from SB SR 436	3,830	4,560	4,350	4,500	5,030	5,370	5,340	5,720	6,300	6,700	7,520
Westbound Off-Ramp to NB SR 436	4,520	4,880	5,030	5,440	5,750	5,680	5,960	6,470	6,930	7,020	7,790
Westbound Off-Ramp to SB SR 436	7,550	8,070	8,130	7,740	8,050	7,990	7,400	9,110	9,340	10,340	11,680
Exit 12 : Goldenrod Road											
Eastbound Off-Ramp	2,670	2,550	2,390	2,480	2,470	2,390	2,890	2,780	3,390	3,690	3,480
Westbound On-Ramp	2,140	1,640	1,650	1,590	1,630	1,990	2,070	2,030	2,560	2,760	2,880

Notes:

1. SR 528 under construction in the Years 2007-2008 at the SR 436 Interchange.
2. SR 528 under construction in the Years 2007-2008 at the Narcoossee Road Interchange.
3. SR 528 under construction in the Years 2008 - 2009 at the Beachline Main Mainline Toll Plaza.
4. SR 528 under construction in the Years 2010-2012 at Dallas Boulevard and the new Dallas Mainline Toll Plaza.
5. Systemwide Toll Increase was applied in July 2012 that included different toll rates for E-PASS and Cash customers.
6. SR 528 under construction in the Year 2013 for bridge deck replacements at Tradeport Drive, Daetwyler Drive and Via Flora Drive.
7. SR 528 under construction in the Year 2015 & 2016 widening and Airport Mainline Toll Plaza removal from Boggy Creek to SR 436.
8. SR 528 and Innovation Way interchange / ICP interchange removal under construction in Years 2017-2018.



SR 528 (BEACHLINE EXPRESSWAY) Interchange - Ramp Volume Summary

Existing and Historical Average Annual Weekday Ramp Terminal Traffic Volumes

Ramp Location	Year 2008	Year 2009	Year 2010	Year 2011	Year 2012	Year 2013	Year 2014	Year 2015	Year 2016	Year 2017	Year 2018
Exit 12 : Goldenrod Road - Continued											
Westbound On-Ramp	510	510	640	580	620	560	670	810	830	850	820
Eastbound On-Ramp	2,910	3,420	2,890	2,920	3,130	3,250	3,450	3,700	4,870	5,370	5,740
Westbound Off-Ramp	2,700	2,705	2,690	2,740	2,900	2,990	3,110	3,160	4,200	4,560	5,080
Exit 13 : Narcoossee Road											
Eastbound Off-Ramp	9,830	9,010	8,980	9,470	10,690	10,840	11,280	11,610	13,140	14,000	15,030
Westbound On-Ramp	9,260	8,680	9,240	9,540	10,610	10,750	10,680	11,100	12,460	13,320	14,320
Eastbound On-Ramp	3,190	2,390	3,360	3,050	2,970	2,960	3,420	3,560	3,940	3,970	4,160
Westbound Off-Ramp	3,440	2,910	3,590	3,160	2,690	3,230	3,110	3,270	3,490	3,180	3,350
Exit 16 : SR 417 (Central Florida GreeneWay)											
Eastbound Off-Ramp to NB SR 417	14,460	13,650	13,570	13,060	13,410	12,750	13,960	13,800	15,700	17,190	18,780
Eastbound Off-Ramp to SB SR 417	250	350	900	870	800	950	1,220	1,410	1,820	2,380	2,800
Westbound On-Ramp from NB SR 417	730	860	990	940	1,030	1,150	1,560	1,610	1,820	2,200	2,290
Westbound On-Ramp from SB SR 417	15,420	15,030	13,500	12,550	13,660	12,740	13,450	13,950	15,340	16,690	16,830
Eastbound On-Ramp from NB SR 417	3,040	2,890	4,020	3,180	3,480	3,790	4,380	4,540	5,990	6,910	6,750
Eastbound On-Ramp from SB SR 417	5,360	4,980	6,030	4,490	5,500	5,180	5,720	5,980	6,700	6,670	7,650
Westbound Off-Ramp to NB SR 417	6,230	5,420	6,690	5,060	5,730	5,890	6,250	6,370	7,180	6,920	7,570
Westbound Off-Ramp to SB SR 417	3,270	2,930	4,440	3,260	3,590	3,860	4,420	5,020	6,000	6,740	7,860

Notes:

1. SR 528 under construction in the Years 2007-2008 at the SR 436 Interchange.
2. SR 528 under construction in the Years 2007-2008 at the Narcoossee Road Interchange.
3. SR 528 under construction in the Years 2008 - 2009 at the Beachline Main Mainline Toll Plaza.
4. SR 528 under construction in the Years 2010-2012 at Dallas Boulevard and the new Dallas Mainline Toll Plaza.
5. Systemwide Toll Increase was applied in July 2012 that included different toll rates for E-PASS and Cash customers.
6. SR 528 under construction in the Year 2013 for bridge deck replacements at Tradeport Drive, Daetwyler Drive and Via Flora Drive.
7. SR 528 under construction in the Year 2015 & 2016 widening and Airport Mainline Toll Plaza removal from Boggy Creek to SR 436.
8. SR 528 and Innovation Way interchange / ICP interchange removal under construction in Years 2017-2018.



SR 528 (BEACHLINE EXPRESSWAY) Interchange - Ramp Volume Summary

Existing and Historical Average Annual Weekday Ramp Terminal Traffic Volumes

Ramp Location	Year 2008	Year 2009	Year 2010	Year 2011	Year 2012	Year 2013	Year 2014	Year 2015	Year 2016	Year 2017	Year 2018
Exit 19 : Innovation Way											
Eastbound Off-Ramp	1,400	1,220	2,670	2,780	3,710	4,020	4,740	4,830	4,920	5,700	5,690
Westbound On-Ramp	1,410	1,240	3,030	3,050	3,950	4,500	4,260	4,840	5,410	6,120	5,830
Westbound On-Loop Ramp	-----	-----	-----	-----	-----	-----	-----	-----	-----	-----	900
Eastbound On-Ramp	250	280	690	560	580	750	890	900	1,020	1,200	930
Westbound Off-Ramp	270	310	720	580	560	690	780	850	1,030	1,090	1,090
Exit 24 : Dallas Boulevard											
Eastbound Off-Ramp	2,030	1,600	1,890	1,600	1,620	1,870	1,950	1,970	2,610	2,690	2,810
Westbound On-Ramp	2,480	1,920	2,260	1,860	1,930	2,150	2,270	2,210	2,930	2,960	3,100
Exit 31 : SR 520											
Eastbound Off-Ramp	4,920	4,550	4,470	4,460	4,480	4,240	4,520	4,590	4,600	6,130	5,100
Westbound On-Ramp	5,430	3,910	3,930	3,820	3,920	3,730	3,610	3,820	3,820	5,220	3,900

Notes:

1. SR 528 under construction in the Years 2007-2008 at the SR 436 Interchange.
2. SR 528 under construction in the Years 2007-2008 at the Narcoossee Road Interchange.
3. SR 528 under construction in the Years 2008 - 2009 at the Beachline Main Mainline Toll Plaza.
4. SR 528 under construction in the Years 2010-2012 at Dallas Boulevard and the new Dallas Mainline Toll Plaza.
5. Systemwide Toll Increase was applied in July 2012 that included different toll rates for E-PASS and Cash customers.
6. SR 528 under construction in the Year 2013 for bridge deck replacements at Tradeport Drive, Daetwyler Drive and Via Flora Drive.
7. SR 528 under construction in the Year 2015 & 2016 widening and Airport Mainline Toll Plaza removal from Boggy Creek to SR 436.
8. SR 528 and Innovation Way interchange / ICP interchange removal under construction in Years 2017-2018.



SR 528 (BEACHLINE EXPRESSWAY) Interchange - Ramp Volume Summary

Central Florida GreeneWay



2018 Traffic Data and Statistics Manual
CENTRAL FLORIDA EXPRESSWAY AUTHORITY

Existing and Historical Average Annual Weekday Mainline Traffic Volumes

Location	Year 2008	Year 2009	Year 2010	Year 2011	Year 2012	Year 2013	Year 2014	Year 2015	Year 2016	Year 2017	Year 2018
International Drive to John Young Parkway	43,530	38,200	39,630	41,400	41,300	41,840	44,780	51,500	62,150	75,150	80,370
John Young Parkway to Orange Blossom Trail	43,000	37,205	37,620	40,400	40,610	41,850	45,940	53,210	64,650	79,200	85,050
Orange Blossom Trail to Florida Turnpike	40,610	35,085	36,450	37,300	38,170	39,850	44,260	51,780	63,880	78,840	85,050
Florida Turnpike to Landstar Boulevard	40,610	35,085	36,450	37,300	38,170	39,850	44,260	57,230	70,150	86,230	94,050
Landstar Boulevard to South Access (OIA)/Boggy Creek Road	40,390	35,900	36,520	38,300	38,350	40,300	44,880	54,580	66,700	76,520	83,300
South Access (OIA)/Boggy Creek Road to Lake Nona Boulevard	30,370	27,730	28,640	30,530	30,790	32,610	39,110	46,140	51,490	61,260	68,520
Lake Nona Boulevard to Narcoossee Road	29,860	27,220	28,290	29,990	29,930	33,500	38,020	44,980	53,040	61,070	68,180
Narcoossee Road to Moss Park Road	-----	-----	31,510	30,670	30,940	35,250	40,480	48,510	57,750	65,750	74,640
Moss Park Road to Innovation Way/Dowden Road	-----	-----	36,120	35,250	35,670	40,170	45,600	54,310	64,230	72,160	81,870
Innovation Way/Dowden Road to SR 528 (Beachline Expressway)	33,120	31,280	36,540	35,610	36,080	39,720	46,230	55,650	64,860	73,930	83,650
SR 528 (Beachline Expressway) to Lee Vista Boulevard	65,720	61,200	61,130	60,010	62,600	64,910	70,860	82,510	94,850	103,010	113,330
Lee Vista Boulevard to Curry Ford Road	68,900	63,300	63,160	62,530	64,950	66,575	73,770	86,030	97,280	104,190	114,750
Curry Ford Road to SR 408/SR 417 Systems Interchange	62,250	56,740	59,170	57,640	61,640	65,080	69,700	83,390	90,030	94,500	108,140
SR 408/SR 417 Systems Interchange to SR 50 (Colonial Dr)	79,430	74,150	76,570	76,980	74,720	73,840	76,920	89,760	98,570	103,480	109,160
SR 50 (Colonial Dr) to University Boulevard	75,550	70,500	72,900	74,900	-----	71,670	-----	86,650	95,670	100,740	106,610
University Boulevard to Orange / Seminole County Line	61,075	56,110	57,860	59,530	56,300	58,140	61,680	70,500	78,110	84,260	88,650

Notes:

1. \$0.25 Toll Increase was applied systemwide at various locations in April 2009 and 2012.
2. SR 417 under construction in the Years 2010-2011 from SR 528 to North of Curry Ford and from SR 408 to SR 50 (Colonial Drive).
3. In the Year 2011, Valencia College Lane Southbound On and Off Ramps and Southbound 408 / 417 Spur were removed due to the new ramp alignment as part of the 408-253E-E1 project at the SR 408 System Interchange.
4. In the Year 2012, Valencia College Lane Northbound On and Off Ramps and Northbound 408 / 417 Spur were removed due to the new ramp alignment as part of the 408-253E-E1 project at the SR 408 System Interchange.
5. Systemwide Toll Increase was applied in July 2012 that included different toll rates for E-PASS and Cash customers.
6. 24 Hour Machine counts were used for SR 417 NB Off-Ramp to Florida's Turnpike and SR 417 SB Off Ramp to Florida's Turnpike in 2017.
7. Exit 17A; South Access Rd opened in 2016.
8. Florida's Turnpike Southbound Off Ramp to Northbound Turnpike and SR 417 Northbound Off Ramps to Florida's Turnpike opened May 2016.



SR 417 (CENTRAL FLORIDA GREENEWAY) Mainline Volume Summary

Existing and Historical Average Annual Weekday Ramp Terminal Traffic Volumes

Ramp Location	Year 2008	Year 2009	Year 2010	Year 2011	Year 2012	Year 2013	Year 2014	Year 2015	Year 2016	Year 2017	Year 2018
Exit 6 : International Drive											
Northbound On-Ramp	10,970	10,270	9,300	9,900	9,850	10,160	11,230	11,890	13,840	15,820	16,680
Southbound Off-Ramp	11,300	9,760	9,940	10,370	10,270	10,270	10,700	11,980	13,490	14,720	15,520
Exit 10 : John Young Parkway											
Northbound Off-Ramp	4,600	4,125	4,620	4,180	4,270	4,150	4,230	4,500	5,170	5,220	5,370
Southbound On-Ramp	4,490	4,120	4,500	4,250	4,020	4,010	4,060	4,260	4,626	4,950	5,400
Northbound On-Ramp	4,240	3,630	3,600	3,690	3,890	4,080	4,830	5,270	5,930	8,910	10,340
Southbound Off-Ramp	2,700	2,260	2,200	2,340	2,320	2,460	2,850	3,000	3,440	5,540	5,910
Southbound Off-Ramp to NB JYP	-----	-----	-----	-----	-----	-----	-----	-----	-----	2,080	2,220
Southbound Off-Ramp to SB JYP	-----	-----	-----	-----	-----	-----	-----	-----	-----	3,460	3,690
Exit 11 : US 17-92 / US 441											
Northbound Off-Ramp	4,200	3,630	3,810	4,030	3,840	3,930	4,250	4,520	5,210	5,080	5,250
Southbound On-Ramp	4,080	4,000	3,140	4,840	4,420	4,430	4,630	4,930	5,520	5,700	6,120
Northbound On-Ramp	2,780	2,610	2,710	2,700	2,740	3,070	3,350	3,690	4,160	5,570	6,180
Southbound Off-Ramp	3,110	2,900	3,070	3,070	3,080	3,400	3,870	4,210	4,810	4,950	5,200
Exit 12 : Florida Turnpike											
Northbound Off-Ramp to NB Turnpike	-----	-----	-----	-----	-----	-----	-----	-----	-----	3,370	5,020
Northbound Off-Ramp to SB Turnpike	-----	-----	-----	-----	-----	-----	-----	-----	-----	5,860	7,240
Northbound On-Ramp from NB Turnpike	-----	-----	-----	-----	-----	-----	-----	3,120	4,030	7,110	8,660
Southbound Off-Ramp to NB Turnpike	-----	-----	-----	-----	-----	-----	-----	-----	-----	6,150	7,870
Southbound Off-Ramp to SB Turnpike	-----	-----	-----	-----	-----	-----	-----	2,580	3,330	4,200	4,900
Exit 14 : Landstar Boulevard											
Northbound Off-Ramp	4,340	2,720	2,730	2,910	3,010	3,210	3,750	5,500	6,520	7,550	7,910
Southbound On-Ramp	4,110	3,230	3,190	3,400	3,490	3,560	4,090	5,840	6,870	10,560	11,530
Northbound On-Ramp	4,010	3,745	2,770	3,700	3,380	3,540	3,940	3,980	4,130	4,070	4,300
Southbound Off-Ramp	4,220	3,020	3,220	3,610	3,300	3,560	3,990	4,140	4,510	4,200	4,260

Notes:

1. \$.25 Toll Increase was applied systemwide at various locations in April 2009 and 2012.
2. SR 417 under construction in the Years 2010-2011 from SR 528 to North of Curry Ford and from SR 408 to SR 50 (Colonial Drive).
3. In the Year 2011, Valencia College Lane Southbound On and Off Ramps and Southbound 408 / 417 Spur were removed due to the new ramp alignment as part of the 408-253E-E1 project at the SR 408 System Interchange.
4. In the Year 2012, Valencia College Lane Northbound On and Off Ramps and Northbound 408 / 417 Spur were removed due to the new ramp alignment as part of the 408-253E-E1 project at the SR 408 System Interchange.
5. Systemwide Toll Increase was applied in July 2012 that included different toll rates for E-PASS and Cash customers.
6. 24 Hour Machine counts were used for SR 417 NB Off-Ramp to Florida's Turnpike and SR 417 SB Off Ramp to Florida's Turnpike in 2017.
7. Exit 17A; South Access Rd opened in 2016.
8. Florida's Turnpike Southbound Off Ramp to Northbound Turnpike and SR 417 Northbound Off Ramps to Florida's Turnpike opened May 2016.



SR 417 (CENTRAL FLORIDA GREENEWAY) Interchange - Ramp Volume Summary

Existing and Historical Average Annual Weekday Ramp Terminal Traffic Volumes

Ramp Location	Year 2008	Year 2009	Year 2010	Year 2011	Year 2012	Year 2013	Year 2014	Year 2015	Year 2016	Year 2017	Year 2018
Exit 17A : Int'l Airport (South Access Road)											
Northbound Off-Ramp	-----	-----	-----	-----	-----	-----	-----	-----	8,490	9,540	10,030
Southbound On-Ramp	-----	-----	-----	-----	-----	-----	-----	-----	9,180	9,450	10,330
Northbound On-Ramp	-----	-----	-----	-----	-----	-----	-----	-----	590	1,030	1,890
Southbound Off-Ramp	-----	-----	-----	-----	-----	-----	-----	-----	770	830	1,040
NB Ramp from Boggy Creek to South Access Rd	-----	-----	-----	-----	-----	-----	-----	-----	-----	10,440	10,900
SB Ramp from South Access Rd to Boggy Creek	-----	-----	-----	-----	-----	-----	-----	-----	-----	11,110	11,540
Exit 17B : Boggy Creek Road											
Northbound Off-Ramp	6,910	6,210	5,880	6,140	6,210	5,630	5,840	7,680	2,120	2,470	2,910
Southbound On-Ramp	7,680	6,440	6,860	6,990	6,950	6,670	6,610	8,390	2,070	3,940	4,070
Northbound On-Ramp	2,360	2,350	2,630	2,870	2,950	3,430	3,700	4,020	3,490	3,630	4,520
Southbound Off-Ramp	2,210	2,130	2,230	2,490	2,650	3,030	3,410	3,700	3,300	3,850	4,690
Exit 19 : Lake Nona Boulevard											
Northbound Off-Ramp	760	610	1,080	1,520	1,740	2,000	2,500	3,020	3,460	3,720	4,630
Southbound On-Ramp	510	640	1,080	1,470	1,770	1,870	2,460	2,880	3,120	3,570	4,440
Northbound On-Ramp	390	370	920	1,210	1,320	1,510	2,080	2,990	3,570	3,700	4,460
Southbound Off-Ramp	370	370	890	1,240	1,330	1,500	2,040	2,910	3,400	3,620	4,450
Exit 22 : Narcoossee Road											
Northbound Off-Ramp	3,850	3,250	3,580	3,090	3,120	3,400	3,920	3,960	4,260	5,660	5,760
Southbound On-Ramp	4,160	3,490	3,540	2,820	3,070	3,270	3,850	4,220	4,470	5,620	6,280
Northbound On-Ramp	6,060	5,860	3,360	3,410	3,710	4,420	5,400	6,140	6,840	7,740	9,370
Southbound Off-Ramp	5,210	4,940	3,420	3,180	3,490	4,140	5,000	5,600	6,440	7,610	9,270
Exit 23 : Moss Park Road											
Northbound Off-Ramp	-----	-----	630	720	-----	770	840	940	1,100	1,340	1,490
Southbound On-Ramp	-----	-----	580	660	-----	770	860	980	1,090	1,470	1,770
Northbound On-Ramp	-----	-----	2,870	2,910	3,030	3,190	3,430	3,620	3,950	4,170	4,850
Southbound Off-Ramp	-----	-----	2,950	3,050	3,260	3,220	3,470	3,830	4,320	4,800	5,440

Notes:

1. \$.25 Toll Increase was applied systemwide at various locations in April 2009 and 2012.
2. SR 417 under construction in the Years 2010-2011 from SR 528 to North of Curry Ford and from SR 408 to SR 50 (Colonial Drive).
3. In the Year 2011, Valencia College Lane Southbound On and Off Ramps and Southbound 408 / 417 Spur were removed due to the new ramp alignment as part of the 408-253E-E1 project at the SR 408 System Interchange.
4. In the Year 2012, Valencia College Lane Northbound On and Off Ramps and Northbound 408 / 417 Spur were removed due to the new ramp alignment as part of the 408-253E-E1 project at the SR 408 System Interchange.
5. Systemwide Toll Increase was applied in July 2012 that included different toll rates for E-PASS and Cash customers.
6. 24 Hour Machine counts were used for SR 417 NB Off-Ramp to Florida's Turnpike and SR 417 SB Off Ramp to Florida's Turnpike in 2017.
7. Exit 17A; South Access Rd opened in 2016.
8. Florida's Turnpike Southbound Off Ramp to Northbound Turnpike and SR 417 Northbound Off Ramps to Florida's Turnpike opened May 2016.



SR 417 (CENTRAL FLORIDA GREENEWAY) Interchange - Ramp Volume Summary

Existing and Historical Average Annual Weekday Ramp Terminal Traffic Volumes

Ramp Location	Year 2008	Year 2009	Year 2010	Year 2011	Year 2012	Year 2013	Year 2014	Year 2015	Year 2016	Year 2017	Year 2018
Exit 24 : Dowden Road											
Northbound Off-Ramp	-----	-----	70	100	230	300	480	710	885	1,110	1,840
Southbound On-Ramp	-----	-----	70	90	200	360	590	890	1,130	1,200	2,130
Northbound On-Ramp	-----	-----	240	220	340	670	950	1,280	1,500	1,990	2,590
Southbound Off-Ramp	-----	-----	320	330	500	810	1,180	1,650	2,020	2,410	3,550
Exit 26 : Beachline Expressway (SR 528)											
Northbound Off-Ramp to EB SR 528	3,040	2,890	4,020	3,180	3,480	3,790	4,380	4,540	5,990	6,910	7,750
Northbound Off-Ramp to WB SR 528	730	860	990	940	1,030	1,150	1,560	1,610	1,820	2,200	2,330
Southbound On-Ramp from EB SR 528	250	350	900	870	800	950	1,220	1,410	1,820	2,380	2,840
Southbound On-Ramp from WB SR 528	3,270	2,930	4,440	3,260	3,590	3,860	4,420	5,020	6,000	6,740	7,990
Northbound On-Ramp from EB SR 528	14,660	13,650	13,570	13,060	13,410	12,750	13,960	13,800	15,700	17,190	19,080
Northbound On-Ramp from WB SR 528	6,230	5,420	6,690	5,060	5,730	5,890	6,250	6,370	7,180	6,920	7,700
Southbound Off-Ramp to EB SR 528	5,360	4,980	6,030	4,490	5,500	5,180	5,720	5,980	6,700	6,670	7,780
Southbound Off-Ramp to WB SR 528	15,420	15,030	13,500	12,550	13,660	12,740	13,450	13,950	15,340	16,690	17,110
Exit 27 : Lee Vista Boulevard											
Northbound Off-Ramp	1,300	1,120	1,160	1,070	1,140	1,180	1,440	1,580	2,020	2,260	2,370
Southbound On-Ramp	1,300	1,250	1,410	1,270	1,280	1,270	1,670	1,860	2,160	2,340	2,540
Northbound On-Ramp	2,980	2,300	2,330	2,380	2,460	2,490	2,640	2,680	3,050	4,320	3,670
Southbound Off-Ramp	2,800	2,170	2,270	2,480	2,310	2,420	2,620	2,680	3,030	3,020	3,320
Exit 30 : Curry Ford Road											
Northbound Off-Ramp	7,680	6,830	5,900	5,940	5,690	5,530	6,230	7,100	8,940	9,290	9,530
Southbound On-Ramp	7,270	7,170	5,900	6,380	6,070	5,130	5,490	5,890	6,820	7,770	8,310
Northbound On-Ramp	4,330	3,840	4,070	3,940	4,380	4,170	4,440	4,650	4,860	4,720	5,150
Southbound Off-Ramp	3,970	3,600	3,740	3,490	4,070	3,820	4,230	4,520	4,810	4,610	5,060

Notes:

1. \$.25 Toll Increase was applied systemwide at various locations in April 2009 and 2012.
2. SR 417 under construction in the Years 2010-2011 from SR 528 to North of Curry Ford and from SR 408 to SR 50 (Colonial Drive).
3. In the Year 2011, Valencia College Lane Southbound On and Off Ramps and Southbound 408 / 417 Spur were removed due to the new ramp alignment as part of the 408-253E-E1 project at the SR 408 System Interchange.
4. In the Year 2012, Valencia College Lane Northbound On and Off Ramps and Northbound 408 / 417 Spur were removed due to the new ramp alignment as part of the 408-253E-E1 project at the SR 408 System Interchange.
5. Systemwide Toll Increase was applied in July 2012 that included different toll rates for E-PASS and Cash customers.
6. 24 Hour Machine counts were used for SR 417 NB Off-Ramp to Florida's Turnpike and SR 417 SB Off Ramp to Florida's Turnpike in 2017.
7. Exit 17A; South Access Rd opened in 2016.
8. Florida's Turnpike Southbound Off Ramp to Northbound Turnpike and SR 417 Northbound Off Ramps to Florida's Turnpike opened May 2016.



SR 417 (CENTRAL FLORIDA GREENEWAY) Interchange - Ramp Volume Summary

Existing and Historical Average Annual Weekday Ramp Terminal Traffic Volumes

Ramp Location	Year 2008	Year 2009	Year 2010	Year 2011	Year 2012	Year 2013	Year 2014	Year 2015	Year 2016	Year 2017	Year 2018
Exit 33A&B : SR 408 (East-West Expressway)											
Northbound Off-Ramp to EB SR 408	7,210	6,080	6,220	6,230	6,340	6,040	6,030	7,230	7,660	8,180	9,400
Northbound Off-Ramp to WB SR 408	6,920	7,100	7,530	8,050	8,170	8,190	8,180	10,520	11,910	11,350	14,280
Southbound On-Ramp from EB SR 408	6,400	6,700	7,080	6,950	7,310	7,530	8,620	9,880	11,040	10,690	13,610
Southbound On-Ramp from WB SR 408	6,980	6,520	6,380	6,250	6,850	5,830	6,210	7,130	7,780	8,550	8,860
Northbound On-Ramp from WB SR 408	4,130	3,975	4,220	4,020	3,410	3,590	3,870	4,250	4,770	4,960	4,820
Southbound Off-Ramp to EB SR 408	5,960	3,645	3,620	3,900	3,480	3,430	3,740	4,000	4,590	4,400	5,090
Northbound On-Ramp from EB SR 408	-----	-----	-----	-----	15,090	15,450	16,160	17,540	18,470	18,730	18,890
Southbound Off-Ramp to WB SR 408	-----	-----	-----	15,980	15,290	15,590	15,980	17,030	18,080	18,450	18,950
Exit 34 : SR 50 (East Colonial Drive)											
Northbound Off-Ramp	4,770	3,920	4,140	3,740	4,110	3,840	4,170	4,810	5,120	4,980	5,590
Southbound On-Ramp	3,910	3,190	3,330	3,370	3,550	3,480	3,730	4,250	4,600	4,810	5,040
Northbound On-Ramp	2,450	1,760	1,880	2,070	2,870	2,670	2,950	3,300	3,520	3,650	3,880
Southbound Off-Ramp	2,350	1,700	1,920	2,960	2,820	2,640	2,980	3,290	3,470	3,530	3,710
Exit 37 : University Boulevard											
Northbound Off-Ramp to EB University Blvd	9,475	8,950	9,030	9,610	8,280	7,550	9,560	9,920	10,270	10,110	10,210
Northbound Off Ramp to WB University Blvd	2,350	2,050	2,060	2,010	2,020	1,780	2,060	2,200	2,440	2,470	2,790
Northbound E-PASS Ramp to University Blvd Exit	-----	-----	-----	-----	-----	-----	-----	-----	-----	9,740	9,530
Southbound On-Ramp from EB University Blvd	2,380	2,490	2,390	1,980	1,970	2,130	2,390	2,800	3,840	3,150	3,490
Southbound On Ramp from WB University Blvd	8,330	8,090	8,720	8,970	8,570	8,270	8,710	9,240	9,900	9,760	10,390
Northbound On-Ramp	3,950	3,550	3,500	3,520	3,410	3,300	3,430	3,710	3,990	4,130	4,350
Southbound Off-Ramp	3,950	3,550	3,500	3,520	3,410	3,300	3,430	3,710	3,990	3,850	4,070

Notes:

1. \$.25 Toll Increase was applied systemwide at various locations in April 2009 and 2012.
2. SR 417 under construction in the Years 2010-2011 from SR 528 to North of Curry Ford and from SR 408 to SR 50 (Colonial Drive).
3. In the Year 2011, Valencia College Lane Southbound On and Off Ramps and Southbound 408 / 417 Spur were removed due to the new ramp alignment as part of the 408-253E-E1 project at the SR 408 System Interchange.
4. In the Year 2012, Valencia College Lane Northbound On and Off Ramps and Northbound 408 / 417 Spur were removed due to the new ramp alignment as part of the 408-253E-E1 project at the SR 408 System Interchange.
5. Systemwide Toll Increase was applied in July 2012 that included different toll rates for E-PASS and Cash customers.
6. 24 Hour Machine counts were used for SR 417 NB Off-Ramp to Florida's Turnpike and SR 417 SB Off Ramp to Florida's Turnpike in 2017.
7. Exit 17A; South Access Rd opened in 2016.
8. Florida's Turnpike Southbound Off Ramp to Northbound Turnpike and SR 417 Northbound Off Ramps to Florida's Turnpike opened May 2016.



SR 417 (CENTRAL FLORIDA GREENEWAY) Interchange - Ramp Volume Summary

Western Beltway and Wekiva Parkway



Existing and Historical Average Annual Weekday Mainline Traffic Volumes

Location	Year 2008	Year 2009	Year 2010	Year 2011	Year 2012	Year 2013	Year 2014	Year 2015	Year 2016	Year 2017	Year 2018
Seidel Road to Schofield Road	12,820	11,950	13,070	13,290	14,880	15,600	17,510	22,950	26,790	31,920	35,690
Schofield Road to New Independence Parkway	-----	-----	-----	-----	-----	-----	-----	23,580	27,760	34,580	39,750
New Independence Parkway to CR 535	13,540	12,500	13,700	14,130	15,930	16,620	19,520	26,200	31,570	40,570	47,540
CR 535 to Florida Turnpike / SR 50	34,010	32,510	34,250	34,820	35,740	37,630	41,940	50,770	58,240	65,550	72,890
Florida Turnpike / SR 50 to SR 438	37,350	36,330	38,470	39,440	40,260	43,480	48,290	57,450	65,850	73,100	79,790
SR 438 / Plant St / Franklin St to West Road	32,660	31,930	33,720	34,360	35,840	38,760	43,860	52,620	60,860	67,530	74,300
West Road to Ocoee Apopka Road (CR 437A)	26,990	27,600	29,500	29,600	31,650	34,430	38,930	46,360	53,510	58,710	66,680
Ocoee Apopka Road (CR 437A) to SR 414	24,440	20,500	20,680	20,110	29,320	33,220	37,440	44,190	50,580	55,370	60,920
SR 429 / 414 (SR 414 to West US 441)	-----	-----	-----	-----	-----	18,670	21,320	24,470	28,490	29,910	35,930
West US 441 to Kelly Park Rd (Wekiva Parkway)	-----	-----	-----	-----	-----	-----	-----	-----	-----	8,930	15,790
Kelly Park Rd to SR 453	-----	-----	-----	-----	-----	-----	-----	-----	-----	-----	12,020
SR 453 to SR 46	-----	-----	-----	-----	-----	-----	-----	-----	-----	-----	5,500

Notes:

1. SR 429 & 414 interchange was under construction during the Year 2011 and Year 2012.
2. The SR 429/414 Extension opened to traffic in January 2013. At the same time, the existing north portion of SR 429 from SR 414 to US 441 was re-named SR 451.
3. CR 437A Northbound On and Southbound Off ramps opened to traffic in January 2013.
4. Wekiva Parkway from SR 429 Connector Road to Kelly Park Road opened in July 2017.
5. Wekiva Parkway from Kelly Park Road to SR 46 Interchange opened in April 2018.



SR 429 (WESTERN BELTWAY AND WEKIVA PARKWAY) Mainline Volume Summary

Existing and Historical Average Annual Weekday Ramp Terminal Traffic Volumes

Ramp Location	Year 2008	Year 2009	Year 2010	Year 2011	Year 2012	Year 2013	Year 2014	Year 2015	Year 2016	Year 2017	Year 2018
Exit 13 : Schofield Road											
Northbound Off-Ramp	-----	-----	-----	-----	-----	-----	-----	-----	290	430	490
Southbound On-Ramp	-----	-----	-----	-----	-----	-----	-----	-----	190	220	260
Northbound On-Ramp from WB Schofield Rd	-----	-----	-----	-----	-----	-----	-----	-----	820	1,890	2,540
Northbound On-Ramp from EB Schofield Rd	-----	-----	-----	-----	-----	-----	-----	-----	-----	1,450	3,000
Southbound Off-Ramp	-----	-----	-----	-----	-----	-----	-----	-----	680	1,510	2,150
Exit 15 : New Independence Pkwy											
Northbound Off-Ramp	500	420	390	370	370	530	780	980	1,020	1,290	1,580
Southbound On-Ramp	510	430	380	400	400	490	790	1,030	1,110	1,420	1,650
Northbound On-Ramp	890	720	700	820	920	1,180	1,880	2,410	3,000	4,550	5,690
Southbound Off-Ramp	840	680	700	790	900	1,140	1,790	2,290	2,820	4,190	5,380
Exit 19 : CR 535											
Northbound Off-Ramp	1,390	1,350	1,430	1,550	1,790	1,740	2,000	2,520	2,990	3,410	3,920
Southbound On-Ramp	1,440	1,340	1,390	1,570	1,650	1,750	1,910	2,370	2,750	3,400	3,920
Northbound On-Ramp	11,880	11,440	11,760	11,980	11,710	12,030	12,820	14,090	15,720	15,350	17,150
Southbound Off-Ramp	11,420	11,260	11,610	11,830	11,540	12,060	12,810	14,170	15,790	15,630	16,230
Exits 22 & 23 : FL Turnpike / SR 50											
Northbound On-Ramp from SR 50	2,610	2,580	2,610	2,540	2,750	2,750	2,970	3,480	3,800	3,460	4,260
Southbound Off-Ramp to SR 50	2,670	2,740	2,680	2,430	2,690	2,810	3,170	3,500	3,650	3,970	4,360
Northbound Off-Ramp to NB Turnpike	1,270	1,370	1,760	1,600	1,530	1,840	1,850	2,680	2,890	3,530	3,950
Northbound Off-Ramp to SB Turnpike	8,660	8,130	8,260	8,790	8,450	9,040	9,900	11,900	13,430	14,730	16,150
Southbound On-Ramp from NB Turnpike	7,980	7,700	7,850	8,240	7,920	7,830	8,530	10,110	12,010	12,880	15,040
Southbound On-Ramp from SB Turnpike	1,620	1,680	1,660	1,740	1,920	2,190	2,310	3,150	3,200	3,900	4,580

Notes:

1. SR 429 & 414 interchange was under construction during the Year 2011 and Year 2012.
2. The SR 429/414 Extension opened to traffic in January 2013. At the same time, the existing north portion of SR 429 from SR 414 to US 441 was re-named SR 451.
3. CR 437A Northbound On and Southbound Off ramps opened to traffic in January 2013.
4. Wekiva Parkway from SR 429 Connector Road to Kelly Park Road opened in July 2017.
5. Wekiva Parkway from Kelly Park Road to SR 46 Interchange opened in April 2018.



SR 429 (WESTERN BELTWAY AND WEKIVA PARKWAY) Interchange - Ramp Volume Summary

Existing and Historical Average Annual Weekday Ramp Terminal Traffic Volumes

Ramp Location	Year 2008	Year 2009	Year 2010	Year 2011	Year 2012	Year 2013	Year 2014	Year 2015	Year 2016	Year 2017	Year 2018
Exits 22 & 23 : FL Turnpike / SR 50 (Cont.)											
Northbound Off-Ramp to SR 50	2,330	2,320	2,690	2,190	1,990	1,780	1,900	2,450	2,400	2,380	2,960
Southbound On-Ramp from SR 50	2,480	3,150	2,810	2,380	2,170	2,750	2,100	2,680	2,580	2,440	3,000
Northbound On-Ramp from NB Turnpike	9,630	9,000	9,200	9,340	9,200	9,630	10,410	12,060	14,240	15,820	16,280
Northbound On-Ramp from SB Turnpike	2,680	2,670	3,060	3,040	3,190	3,280	3,680	4,640	5,440	5,350	6,110
Southbound Off-Ramp to NB Turnpike	2,520	2,500	2,990	3,000	3,140	3,130	3,390	4,160	4,770	5,270	6,180
Southbound Off-Ramp to SB Turnpike	9,440	8,680	8,710	9,210	9,270	7,910	8,530	10,120	11,160	12,190	12,920
Exit 24 : SR 438 / Plant Street											
Northbound Off-Ramp	4,130	3,830	4,050	4,010	3,640	3,810	4,150	4,710	5,450	5,650	6,170
Southbound On-Ramp	3,510	3,200	3,420	3,590	3,280	3,550	3,750	4,280	4,740	5,000	5,380
Northbound On-Ramp	1,550	1,200	1,270	1,290	1,110	1,470	1,640	2,000	2,170	2,340	2,750
Southbound Off-Ramp	1,400	1,430	1,450	1,230	1,390	1,500	1,680	1,900	2,040	2,610	2,650
Exit 26 : West Road											
Northbound Off-Ramp	3,410	2,630	2,590	2,640	2,590	2,740	3,260	3,860	4,760	5,410	6,180
Southbound On-Ramp	3,360	2,720	2,700	2,980	2,730	2,790	3,270	3,870	4,690	5,380	6,080
Northbound On-Ramp	560	520	540	420	530	620	800	810	950	1,020	1,370
Southbound Off-Ramp	540	500	530	440	600	570	720	730	840	1,010	1,350
Exit 29 : CR 437A (Ocoee Apopka Road)											
Northbound Off-Ramp	1,300	3,510	4,450	4,880	1,170	1,230	1,420	1,700	1,960	2,520	2,850
Southbound On-Ramp	1,250	3,590	4,370	4,610	1,160	1,200	1,420	1,800	1,990	2,610	2,990
Northbound On-Ramp	-----	-----	-----	-----	-----	500	570	680	740	900	1,140
Southbound Off-Ramp	-----	-----	-----	-----	-----	450	500	780	820	800	1,050

Notes:

1. SR 429 & 414 interchange was under construction during the Year 2011 and Year 2012.
2. The SR 429/414 Extension opened to traffic in January 2013. At the same time, the existing north portion of SR 429 from SR 414 to US 441 was re-named SR 451.
3. CR 437A Northbound On and Southbound Off ramps opened to traffic in January 2013.
4. Wekiva Parkway from SR 429 Connector Road to Kelly Park Road opened in July 2017.
5. Wekiva Parkway from Kelly Park Road to SR 46 Interchange opened in April 2018.



SR 429 (WESTERN BELTWAY AND WEKIVA PARKWAY) Interchange - Ramp Volume Summary

Existing and Historical Average Annual Weekday Ramp Terminal Traffic Volumes

Ramp Location	Year 2008	Year 2009	Year 2010	Year 2011	Year 2012	Year 2013	Year 2014	Year 2015	Year 2016	Year 2017	Year 2018
Exit 30 : SR 414 (Apopka Expressway)											
Northbound Off-Ramp to SR 414 / 451	-----	-----	-----	-----	5,030	6,040	7,220	14,040	16,360	17,410	17,850
Northbound Off-Ramp to EB SR 414	-----	-----	-----	-----	5,030	6,040	7,220	8,950	10,620	10,470	12,180
Northbound Off-Ramp to NB SR 451	-----	-----	-----	-----	-----	-----	-----	5,090	5,740	6,940	5,670
Southbound On-Ramp from WB SR 414	-----	-----	-----	-----	4,960	5,700	6,920	8,130	9,990	9,640	12,100
Southbound On-Ramp from SB 451	-----	-----	-----	-----	-----	-----	-----	6,190	6,500	4,290	6,040
Northbound On-Ramp from WB SR 414	-----	-----	-----	-----	-----	3,050	3,410	3,950	4,700	4,290	5,680
Southbound Off-Ramp to EB SR 414	-----	-----	-----	-----	-----	3,080	3,510	3,990	4,630	4,210	5,440
Exit 34: SR 429 Connector Road (US 441/CR 437)											
Northbound Off-Ramp	-----	-----	-----	-----	-----	9,330	10,950	12,420	14,310	10,260	7,860
Southbound On-Ramp	-----	-----	-----	-----	-----	7,050	7,410	7,240	8,340	12,870	14,310
Northbound On-Ramp	-----	-----	-----	-----	-----	-----	-----	-----	-----	170	480
Southbound Off-Ramp	-----	-----	-----	-----	-----	-----	-----	-----	-----	300	520
Exit 38: Kelly Park Road											
Northbound Off-Ramp	-----	-----	-----	-----	-----	-----	-----	-----	-----	4,720	2,940
Southbound On-Ramp	-----	-----	-----	-----	-----	-----	-----	-----	-----	4,210	3,130
Northbound On-Ramp	-----	-----	-----	-----	-----	-----	-----	-----	-----	-----	380
Northbound Loop On-Ramp	-----	-----	-----	-----	-----	-----	-----	-----	-----	-----	310
Southbound Off-Ramp	-----	-----	-----	-----	-----	-----	-----	-----	-----	-----	630
Exit 39: Wekiva Parkway (SR 453)											
Northbound Off-Ramp	-----	-----	-----	-----	-----	-----	-----	-----	-----	-----	3,350
Southbound On-Ramp	-----	-----	-----	-----	-----	-----	-----	-----	-----	-----	2,310
Northbound On-Ramp	-----	-----	-----	-----	-----	-----	-----	-----	-----	-----	70
Southbound Off-Ramp	-----	-----	-----	-----	-----	-----	-----	-----	-----	-----	100

Notes:

1. SR 429 & 414 interchange was under construction during the Year 2011 and Year 2012.
2. The SR 429/414 Extension opened to traffic in January 2013. At the same time, the existing north portion of SR 429 from SR 414 to US 441 was re-named SR 451.
3. CR 437A Northbound On and Southbound Off ramps opened to traffic in January 2013.
4. Wekiva Parkway from SR 429 Connector Road to Kelly Park Road opened in July 2017.
5. Wekiva Parkway from Kelly Park Road to SR 46 Interchange opened in April 2018.



SR 429 (WESTERN BELTWAY AND WEKIVA PARKWAY) Interchange - Ramp Volume Summary

Apopka Expressway



Existing and Historical Average Annual Weekday Mainline Traffic Volumes

Location	Year 2009	Year 2010	Year 2011	Year 2012	Year 2013	Year 2014	Year 2015	Year 2016	Year 2017	Year 2018
SR 451 / SR 429 to Marden Road	10,500	13,025	13,820	16,320	20,870	24,120	29,100	33,900	36,790	39,250
Marden Road to Keene Road	-----	-----	-----	-----	-----	-----	-----	-----	36,500	41,500
Keene Road to Hiwassee Road	12,400	16,075	17,580	20,590	24,670	28,290	33,500	38,600	41,870	45,740
Hiwassee Road to US 441 (Orange Blossom Trail)	13,780	18,205	20,080	21,990	25,900	28,810	34,200	38,700	41,110	44,400
US 441 (Orange Blossom Trail) to Rose Avenue / Bear Lake Road	27,340	31,075	32,240	34,040	35,290	37,790	42,400	44,300	45,080	45,230

Notes:

1. SR 414 Apopka Expressway Partially Opened to traffic in February 2009, fully opened to traffic in May 2009.
2. SR 429 & 414 interchange was under construction during the Year 2011 and Year 2012.
3. Systemwide Toll Increase was applied in July 2012 that included different toll rates for E-PASS and Cash customers.
4. The SR 429/414 Extension, which extended SR 414 to the west of SR 451 opened to traffic in January 2013.
5. The Marden Road interchange opened to traffic in June of 2017.



SR 414 (APOPKA EXPRESSWAY) Mainline Volume Summary

Existing and Historical Average Annual Weekday Ramp Terminal Traffic Volumes

Ramp Location	Year 2009	Year 2010	Year 2011	Year 2012	Year 2013	Year 2014	Year 2015	Year 2016	Year 2017	Year 2017
Exit 4B : SR 429 (Western Beltway)										
Eastbound On-Ramp from NB SR 429	-----	-----	-----	5,030	6,040	7,220	8,950	10,620	10,470	12,120
Westbound Off-Ramp to SB SR 429	-----	-----	-----	4,960	5,700	6,920	8,130	9,990	9,640	12,040
Eastbound On-Ramp from SB SR 429 / 414	-----	-----	-----	-----	3,080	3,510	3,990	4,630	4,210	5,410
Westbound Off-Ramp to NB SR 429 / 414	-----	-----	-----	-----	3,050	3,410	3,950	4,700	4,290	5,650
Exit 4A : SR 451										
Eastbound On-Ramp from SR 451 SB	2,390	2,900	3,420	3,710	1,600	1,310	1,550	1,600	2,410	2,390
Westbound Off-Ramp to SR 451 NB	2,190	2,830	3,140	3,030	1,410	1,550	1,730	1,960	2,000	2,020
Eastbound Off-Ramp to SR 451 NB	-----	-----	-----	-----	-----	-----	5,090	5,740	6,970	5,640
Westbound On Ramp from SR 451 SB	-----	-----	-----	-----	-----	-----	6,190	6,500	7,760	6,070
Exit 5 : Marden Road										
Eastbound On-Ramp	-----	-----	-----	-----	-----	-----	-----	-----	680	970
Westbound Off-Ramp	-----	-----	-----	-----	-----	-----	-----	-----	580	900
Exit 6 : Keene Road										
Eastbound On-Ramp	960	1,520	1,910	2,220	2,100	2,090	2,260	2,400	2,620	2,320
Westbound Off-Ramp	940	1,530	1,850	2,050	1,920	1,967	2,140	2,290	2,550	2,310
Exit 8 : Hiwassee Road										
Eastbound Off-Ramp	910	1,010	1,130	1,550	1,600	1,840	2,280	2,550	2,810	3,340
Westbound On-Ramp	890	1,100	1,090	1,430	1,600	1,970	2,430	2,790	2,780	2,990
Eastbound On-Ramp	1,550	2,100	2,350	2,220	2,210	2,250	2,530	2,490	2,460	2,470
Westbound Off-Ramp	1,630	2,140	2,370	2,160	2,210	2,450	2,630	2,620	2,490	2,510
Exit 9 : US 441 (Orange Blossom Trail)										
Eastbound Off-Ramp	1,190	1,460	1,610	1,940	2,130	2,430	2,980	3,780	4,260	5,010
Westbound On-Ramp from NB US 441	835	1,085	1,070	1,320	1,420	1,660	2,050	2,560	2,910	3,390
Westbound On-Ramp from SB US 441	165	215	210	280	390	390	430	550	610	730
Eastbound On-Ramp	7,000	7,130	6,920	6,940	5,870	5,660	5,770	5,270	5,020	2,840
Westbound Off-Ramp	8,750	8,500	8,130	8,650	7,600	7,720	7,900	7,280	6,770	7,200

Notes:

1. SR 414 Apopka Expressway Partially Opened to traffic in February 2009, fully opened to traffic in May 2009.
2. SR 429 & 414 interchange was under construction during the year 2011 and year 2012.
3. Systemwide Toll Increase was applied in July 2012 that included different toll rates for E-PASS and Cash customers.
4. The SR 429/414 Extension, which extended SR 414 to the west of SR 451 opened to traffic in January 2013.
5. The Marden Road interchange opened to traffic in June of 2017.



SR 414 (APOPKA EXPRESSWAY) Interchange - Ramp Volume Summary

Western Beltway Connector Road



Existing and Historical Average Annual Weekday Mainline Traffic Volumes

Segment Location	Year 2008	Year 2009	Year 2010	Year 2011	Year 2012	Year 2013	Year 2014	Year 2015	Year 2016	Year 2017	Year 2018
SR 429/SR 451 to US 441 (Orange Blossom)	25,080	26,410	26,410	26,670	26,070	12,250	12,820	14,560	15,800	17,300	18,150

Notes:

1. \$0.25 Toll Increase was applied systemwide at various locations in April 2009 and 2012.
2. SR 429 & 414 interchange was under construction during the Year 2011 and Year 2012.
3. Systemwide Toll Increase was applied in July 2012 that included different toll rates for E-PASS and Cash customers.
4. The SR 429 / 414 Extension opened to traffic in January 2013. The existing portion of SR 429 from SR 414 to US 441 was re-named SR 451.



SR 451 (WESTERN BELTWAY CONNECTOR ROAD) Mainline Volume Summary

Existing and Historical Average Annual Weekday Ramp Terminal Traffic Volumes

Ramp Location	Year 2008	Year 2009	Year 2010	Year 2011	Year 2012	Year 2013	Year 2014	Year 2015	Year 2016	Year 2017	Year 2018
Exit 4A: SR 414 East / SR 429 South											
Northbound On-Ramp from NB SR 429	-----	-----	-----	-----	9,415	4,130	4,570	5,090	5,740	6,910	5,640
Southbound Off-Ramp to SB SR 429	-----	-----	-----	-----	10,120	5,090	5,330	6,190	6,500	7,680	6,010
Northbound On-Ramp from WB SR 414	-----	2,190	2,830	3,140	2,825	1,410	1,550	1,730	1,960	2,000	2,020
Southbound Off-Ramp to EB SR 414	-----	2,390	2,900	3,420	3,710	1,600	1,310	1,550	1,600	1,870	2,390
Expressway Ends : US 441 (OBT) & Vick Road											
Northbound Off-Ramp	12,080	12,685	12,980	13,110	12,240	5,660	5,960	6,820	7,700	8,890	7,670
Southbound On-Ramp from SB US 441	7,720	8,245	9,150	9,250	9,960	2,760	2,660	2,840	2,930	3,170	2,810
Southbound On-Ramp from NB US 441	4,640	4,150	4,280	4,310	3,870	3,840	4,260	4,900	5,170	6,400	7,670

Notes:

1. \$0.25 Toll Increase was applied systemwide at various locations in April 2009 and 2012.
2. SR 429 & 414 interchange was under construction during the Year 2011 and Year 2012.
3. Systemwide Toll Increase was applied in July 2012 that included different toll rates for E-PASS and Cash customers.
4. The SR 429 / 414 Extension opened to traffic in January 2013. The existing portion of SR 429 from SR 414 to US 441 was re-named SR 451.



SR 451 (WESTERN BELTWAY CONNECTOR ROAD) Interchange - Ramp Volume Summary

SR 453



Existing and Historical Average Annual Weekday Mainline Traffic Volumes

Segment Location	Year 2008	Year 2009	Year 2010	Year 2011	Year 2012	Year 2013	Year 2014	Year 2015	Year 2016	Year 2017	Year 2018
SR 429 to SR 46	-----	-----	-----	-----	-----	-----	-----	-----	-----	-----	5,210

Notes:
 1. SR 453 opened in March 2018.



**SR 453 (WESTERN BELTWAY CONNECTOR ROAD)
 Mainline Volume Summary**

Existing and Historical Average Annual Weekday Ramp Terminal Traffic Volumes

Ramp Location	Year 2008	Year 2009	Year 2010	Year 2011	Year 2012	Year 2013	Year 2014	Year 2015	Year 2016	Year 2017	Year 2018
Exit To & From SR 429											
Northbound On-Ramp from NB SR 429	-----	-----	-----	-----	-----	-----	-----	-----	-----	-----	3,000
Southbound Off-Ramp to SB SR 429	-----	-----	-----	-----	-----	-----	-----	-----	-----	-----	2,060
Northbound On-Ramp from SB 429	-----	-----	-----	-----	-----	-----	-----	-----	-----	-----	90
Northbound On-Ramp from SB 429	-----	-----	-----	-----	-----	-----	-----	-----	-----	-----	60
Expressway Ends : SR 46											
Northbound Off-Ramp	-----	-----	-----	-----	-----	-----	-----	-----	-----	-----	3,080
Southbound On-Ramp	-----	-----	-----	-----	-----	-----	-----	-----	-----	-----	2,130

Notes:

1. SR 453 opened in March 2018.



SR 453 (WESTERN BELTWAY CONNECTOR ROAD) Interchange - Ramp Volume Summary

Systemwide Adjustment Factors



Weekday, Daily and Monthly Adjustment Factors

Annual Average Weekday Traffic (AAWT) is the estimated volume of traffic on a highway and/or expressway segment for five (5) days of the week (Monday through Friday) that is obtained from collecting 24 hour, 72 hour traffic counts and/or monthly traffic counts and adjusting these collected weekday traffic counts by utilizing the developed daily and monthly seasonal adjustment factors.

All weekday traffic volumes collected must be adjusted to reflect the seasonal changes in traffic volumes. In order to calculate the AAWT and AADT, monthly seasonal adjustment factors are calculated from each of the mainline toll plaza transactions for each month of the year. These numbers are then used to convert the twenty-four hour Weekday Traffic Counts to AAWT.

In addition to developing the AAWT, seasonal adjustment factors and a conversion factor to calculate the Average Annual Daily Traffic (AADT) are also tabulated. The AADT is the estimated daily traffic volume on a highway and/or expressway for all days of the week, (Monday through Sunday) over the period of one year. The AADT is obtained by taking similar adjustment factors developed from the mainline and ramp toll plaza transactions and applying those factors to the same twenty-four hour weekday traffic counts. This calculated conversion factor is used to convert the AAWT to AADT by multiplying the appropriate factor to the corresponding AAWT to obtain the AADT traffic volume.

The following tables summarize the daily and monthly adjustment factors for the Central Florida Expressway Authority's system. Note that these adjustment factors are based on the year 2018 mainline toll plaza transactions and accounts for the number of weekdays, weekends and holidays occurring each month.

Average Annual Weekday Traffic (AAWT)

Monthly Seasonal Conversion Factors

CFX Expressway System	AAWT Monthly Conversion Factors					
	January	February	March	April	May	June
SR 408 (East-West Expressway)						
Florida Turnpike (SR 91) to Interstate 4 (I-4)	1.0220	0.9507	1.0908	0.9458	0.9878	0.9795
Interstate 4 (I-4) to SR 50 (East Colonial Drive)	0.9912	0.9351	1.0790	0.9365	0.9753	0.9864
SR 528 (Beachline Expressway)						
Boggy Creek Road to SR 417 (Central Florida GreeneWay)	0.9692	0.9740	1.0820	1.0236	0.9356	1.0315
SR 417 (Central Florida GreeneWay) to SR 520	1.0625	0.9679	0.9566	0.9475	0.9988	0.9667
SR 417 (Central Florida GreeneWay)						
International Drive to SR 528 (Beachline Expressway)	1.0117	0.9644	0.9751	0.9532	0.9925	0.9665
SR 528 (Beachline Expressway) to Orange/Seminole County Line	1.0206	0.9505	1.0431	0.9453	0.9876	0.9706
SR 429 (Western Beltway and Wekiva Parkway)						
Seidel Road to CR 535 (Old Winter Garden Road)	1.0769	0.9935	1.0427	0.9685	0.9969	0.9456
CR 535 (Old Winter Garden Road to US 441 (Orange Blossom Trail))	1.0391	0.9694	1.0715	0.9466	0.9670	0.9453
SR 414 (Apopka Expressway)						
SR 429 / SR 451 to US 441 (Orange Blossom Trail)	0.9199	0.8548	0.9266	0.8469	0.8855	0.8696
SR 451 (Western Beltway Connector Road)						
SR 429 / SR 451 to US 441 (Orange Blossom Trail)	0.9795	0.9121	0.9991	0.8968	0.9263	0.9074
SR 453						
SR 429 / SR 453 to SR 46	1.0391	0.9694	1.0715	0.9466	0.9670	0.9453

CFX Expressway System	AAWT Monthly Conversion Factor					
	July	August	September	October	November	December
SR 408 (East-West Expressway)						
Florida Turnpike (SR 91) to Interstate 4 (I-4)	1.0052	0.9636	0.9845	1.1130	0.9710	1.0162
Interstate 4 (I-4) to SR 50 (East Colonial Drive)	1.0142	0.9854	0.9804	1.1089	0.9876	1.0510
SR 528 (Beachline Expressway)						
Boggy Creek Road to SR 417 (Central Florida GreeneWay)	1.0775	0.9855	0.9489	0.9470	1.0197	1.0055
SR 417 (Central Florida GreeneWay) to SR 520	0.9476	0.9913	1.0372	1.1705	0.9910	1.0031
SR 417 (Central Florida GreeneWay)						
International Drive to SR 528 (Beachline Expressway)	0.9685	1.0076	1.0522	1.1888	0.9808	0.9804
SR 528 (Beachline Expressway) to Orange/Seminole County Line	0.9991	0.9785	0.9911	1.1198	0.9867	1.0310
SR 429 (Western Beltway and Wekiva Parkway)						
Seidel Road to CR 535 (Old Winter Garden Road)	0.9471	0.9650	1.0051	1.1341	0.9609	0.9580
CR 535 (Old Winter Garden Road to US 441 (Orange Blossom Trail))	0.9831	0.9629	0.9961	1.1253	0.9744	1.0245
SR 414 (Apopka Expressway)						
SR 429 / SR 451 to US 441 (Orange Blossom Trail)	0.9067	0.8704	1.0033	1.1339	0.9442	0.9952
SR 451 (Western Beltway Connector Road)						
SR 429 / SR 451 to US 441 (Orange Blossom Trail)	0.9449	0.9166	0.9997	1.1296	0.9593	1.0098
SR 453						
SR 429 / SR 453 to SR 46	0.9831	0.9629	0.9961	1.1253	0.9744	1.0245

Notes:

1. Due to prolonged lane closures during the month of November 2017, adjustment factors were used.
2. SR 453 opened to traffic in March of 2018. Due to not having a full years worth of traffic counts, the seasonal factors for SR 453 will match the north end of SR 429.



Average Annual Daily Traffic (AAWT)

Monthly Seasonal Conversion Factors

CFX Expressway System	AADT Monthly Conversion Factors					
	January	February	March	April	May	June
SR 408 (East-West Expressway)						
Florida Turnpike (SR 91) to Interstate 4 (I-4)	1.0345	0.9624	1.0035	0.9562	1.0043	0.9997
Interstate 4 (I-4) to SR 50 (East Colonial Drive)	0.9987	0.9493	1.0082	0.9487	0.9929	1.0059
SR 528 (Beachline Expressway)						
Boggy Creek Road to SR 417 (Central Florida GreeneWay)	0.9601	0.9647	1.0716	1.0112	0.9386	1.1289
SR 417 (Central Florida GreeneWay) to SR 520	1.0809	0.9787	0.9259	0.9586	1.0243	0.9711
SR 417 (Central Florida GreeneWay)						
International Drive to SR 528 (Beachline Expressway)	1.0291	0.9785	0.9371	0.9621	1.0104	0.9805
SR 528 (Beachline Expressway) to Orange/Seminole County Line	1.0336	0.9673	0.9607	0.9586	1.0066	0.9893
SR 429 (Western Beltway and Wekiva Parkway)						
Seidel Road to CR 535 (Old Winter Garden Road)	1.1481	1.0492	0.9974	1.0174	1.0622	0.9946
CR 535 (Old Winter Garden Road to US 441 (Orange Blossom Trail)	1.1384	1.0542	1.0620	1.0305	1.0621	1.0355
SR 414 (Apopka Expressway)						
SR 429 / SR 451 to US 441 (Orange Blossom Trail)	0.9386	0.8668	0.8397	0.8588	0.9030	0.8848
SR 451 (Western Beltway Connector Road)						
SR 429 / SR 451 to US 441 (Orange Blossom Trail)	1.0385	0.9605	0.9508	0.9446	0.9825	0.9601
SR 453						
SR 429 / SR 453 to SR 46	1.1384	1.0542	1.0620	1.0305	1.0621	1.0355

CFX Expressway System	AADT Monthly Conversion Factor					
	July	August	September	October	November	December
SR 408 (East-West Expressway)						
Florida Turnpike (SR 91) to Interstate 4 (I-4)	1.0249	0.9835	1.0029	1.0415	0.9752	1.0214
Interstate 4 (I-4) to SR 50 (East Colonial Drive)	1.0327	1.0037	0.9949	1.0302	0.9944	1.0515
SR 528 (Beachline Expressway)						
Boggy Creek Road to SR 417 (Central Florida GreeneWay)	1.0905	0.9705	0.9181	0.9541	0.9995	0.9921
SR 417 (Central Florida GreeneWay) to SR 520	0.9602	0.9919	1.0448	1.0568	1.0077	1.0222
SR 417 (Central Florida GreeneWay)						
International Drive to SR 528 (Beachline Expressway)	0.9832	1.0203	1.0676	1.0874	0.9846	0.9801
SR 528 (Beachline Expressway) to Orange/Seminole County Line	1.0158	0.9959	1.0082	1.0459	0.9953	1.0325
SR 429 (Western Beltway and Wekiva Parkway)						
Seidel Road to CR 535 (Old Winter Garden Road)	1.0041	1.0308	1.0717	1.1015	0.9504	1.0032
CR 535 (Old Winter Garden Road to US 441 (Orange Blossom Trail)	1.0738	1.0556	1.0943	1.1355	0.9663	1.1055
SR 414 (Apopka Expressway)						
SR 429 / SR 451 to US 441 (Orange Blossom Trail)	0.9197	0.8873	1.0322	1.0830	0.9392	0.9946
SR 451 (Western Beltway Connector Road)						
SR 429 / SR 451 to US 441 (Orange Blossom Trail)	0.9967	0.9714	1.0633	1.1093	0.9527	1.0500
SR 453						
SR 429 / SR 453 to SR 46	1.0738	1.0556	1.0943	1.1355	0.9663	1.1055

Notes:

1. Due to prolonged lane closures during the month of November 2017, adjustment factors were used.
2. SR 453 opened to traffic in March of 2018. Due to not having a full years worth of traffic counts, the seasonal factors for SR 453 will match the north end of SR 429.



Average Annual Weekday Traffic (AAWT) to Average Annual Daily Traffic (AADT)

Monthly Seasonal Conversion Factors

CFX Expressway System	AAWT to AADT Monthly Conversion Factors					
	January	February	March	April	May	June
SR 408 (East-West Expressway)						
Florida Turnpike (SR 91) to Interstate 4 (I-4)	0.9152	0.9151	1.0069	0.9162	0.9112	0.9076
Interstate 4 (I-4) to SR 50 (East Colonial Drive)	0.9261	0.9192	0.9986	0.9211	0.9166	0.9150
SR 528 (Beachline Expressway)						
Boggy Creek Road to SR 417 (Central Florida GreeneWay)	1.0110	1.0109	1.0108	1.0082	1.0238	1.1170
SR 417 (Central Florida GreeneWay) to SR 520	0.9849	0.9910	1.0352	0.9904	0.9770	0.9975
SR 417 (Central Florida GreeneWay)						
International Drive to SR 528 (Beachline Expressway)	0.9693	0.9720	1.0258	0.9771	0.9687	0.9720
SR 528 (Beachline Expressway) to Orange/Seminole County Line	0.9154	0.9110	1.0066	0.9143	0.9097	0.9096
SR 429 (Western Beltway and Wekiva Parkway)						
Seidel Road to CR 535 (Old Winter Garden Road)	0.9380	0.9469	1.0454	0.9520	0.9386	0.9507
CR 535 (Old Winter Garden Road to US 441 (Orange Blossom Trail)	0.9128	0.9195	1.0090	0.9185	0.9105	0.9129
SR 414 (Apopka Expressway)						
SR 429 / SR 451 to US 441 (Orange Blossom Trail)	0.8860	0.8916	0.9977	0.8916	0.8866	0.8886
SR 451 (Western Beltway Connector Road)						
SR 429 / SR 451 to US 441 (Orange Blossom Trail)	0.8994	0.9056	1.0033	0.9051	0.8985	0.9007
SR 453						
SR 429 / SR 453 to SR 46	0.9128	0.9195	1.0090	0.9185	0.9105	0.9129

CFX Expressway System	AAWT to AADT Monthly Conversion Factors					
	July	August	September	October	November	December
SR 408 (East-West Expressway)						
Florida Turnpike (SR 91) to Interstate 4 (I-4)	0.9085	0.9075	0.9094	0.9900	0.9223	0.9216
Interstate 4 (I-4) to SR 50 (East Colonial Drive)	0.9164	0.9161	0.9195	1.0044	0.9267	0.9326
SR 528 (Beachline Expressway)						
Boggy Creek Road to SR 417 (Central Florida GreeneWay)	1.0329	1.0051	0.9875	1.0282	1.0004	1.0070
SR 417 (Central Florida GreeneWay) to SR 520	0.9889	1.0014	0.9947	1.1099	0.9854	0.9832
SR 417 (Central Florida GreeneWay)						
International Drive to SR 528 (Beachline Expressway)	0.9714	0.9740	0.9720	1.0782	0.9824	0.9864
SR 528 (Beachline Expressway) to Orange/Seminole County Line	0.9119	0.9110	0.9114	0.9926	0.9192	0.9258
SR 429 (Western Beltway and Wekiva Parkway)						
Seidel Road to CR 535 (Old Winter Garden Road)	0.9432	0.9361	0.9378	1.0296	0.9548	0.9549
CR 535 (Old Winter Garden Road to US 441 (Orange Blossom Trail)	0.9156	0.9122	0.9103	0.9911	0.9194	0.9268
SR 414 (Apopka Expressway)						
SR 429 / SR 451 to US 441 (Orange Blossom Trail)	0.8913	0.8869	0.8787	0.9466	0.8907	0.9046
SR 451 (Western Beltway Connector Road)						
SR 429 / SR 451 to US 441 (Orange Blossom Trail)	0.9034	0.8995	0.8945	0.9688	0.9050	0.9157
SR 453						
SR 429 / SR 453 to SR 46	0.9156	0.9122	0.9103	0.9911	0.9194	0.9268

Notes:

1. Due to prolonged lane closures during the month of November 2017, adjustment factors were used.
2. SR 453 opened to traffic in March of 2018. Due to not having a full years worth of traffic counts, the seasonal factors for SR 453 will match the north end of SR 429.



CFX EXPRESSWAY SYSTEM

Average Annual Weekday Traffic (AAWT) to Average Annual Daily Traffic (AADT)

SECTION II



Section III: Mainline Toll Facility Characteristics



2018 Traffic Data and Statistics Manual
CENTRAL FLORIDA EXPRESSWAY AUTHORITY

Mainline Toll Facility Characteristics Introduction

The following pages provide a summary of the existing unadjusted traffic data gathered at the mainline toll plazas located on the SR 408 (East-West Expressway) at the Hiwassee Mainline, Pine Hills Mainline, Conway Mainline and Dean Mainline, on SR 528 (Beachline Expressway) at the Beachline Mainline and Dallas Mainline, on SR 417 (Central Florida Greeneway) at the John Young Mainline, Boggy Creek Mainline, Curry Ford Mainline and the University Mainline, on SR 429 (Western Beltway and Wekiva Parkway) at the Forest Lake Mainline, Independence Mainline, Ponkan Gantry, and Mt. Plymouth Gantry, on SR 414 (Apopka Expressway) at the Coral Hills Mainline, on SR 453 at the Coronado Gantry, and on the Non System Goldenrod Extension at the Goldenrod Mainline.

The data for the mainline toll plazas includes the following:

- Figures summarizing the type and number of lanes through the Mainline Toll Plaza.
- Mainline and Ramp Toll Plaza monthly toll transactions and revenue obtained from the Monthly Statistical Reports Fiscal Year 2018.
- Typical Total Daily Expressway Traffic obtained for entire month of April (Monday through Sunday) from the toll plaza data statistics (Mainline Tolls Only).
- Unadjusted typical average five-day (weekday) & seven-day (daily) traffic volume summaries obtained from the toll plaza data statistics.
- Unadjusted typical average weekday peak hour characteristics summarizing the peak to daily ratio (“K”) and the directional distribution (“D”) factors.
- Unadjusted typical average weekday transactions summarizing the percentages for electronic E-PASS, Exact Change (ACM) and Change/Receipt (Manual).
- Historical and Existing Year E-PASS, Cash and Violation percentages.

Hiwassee Mainline Toll Facility (East-West Expressway)



2018 Traffic Data and Statistics Manual
CENTRAL FLORIDA EXPRESSWAY AUTHORITY

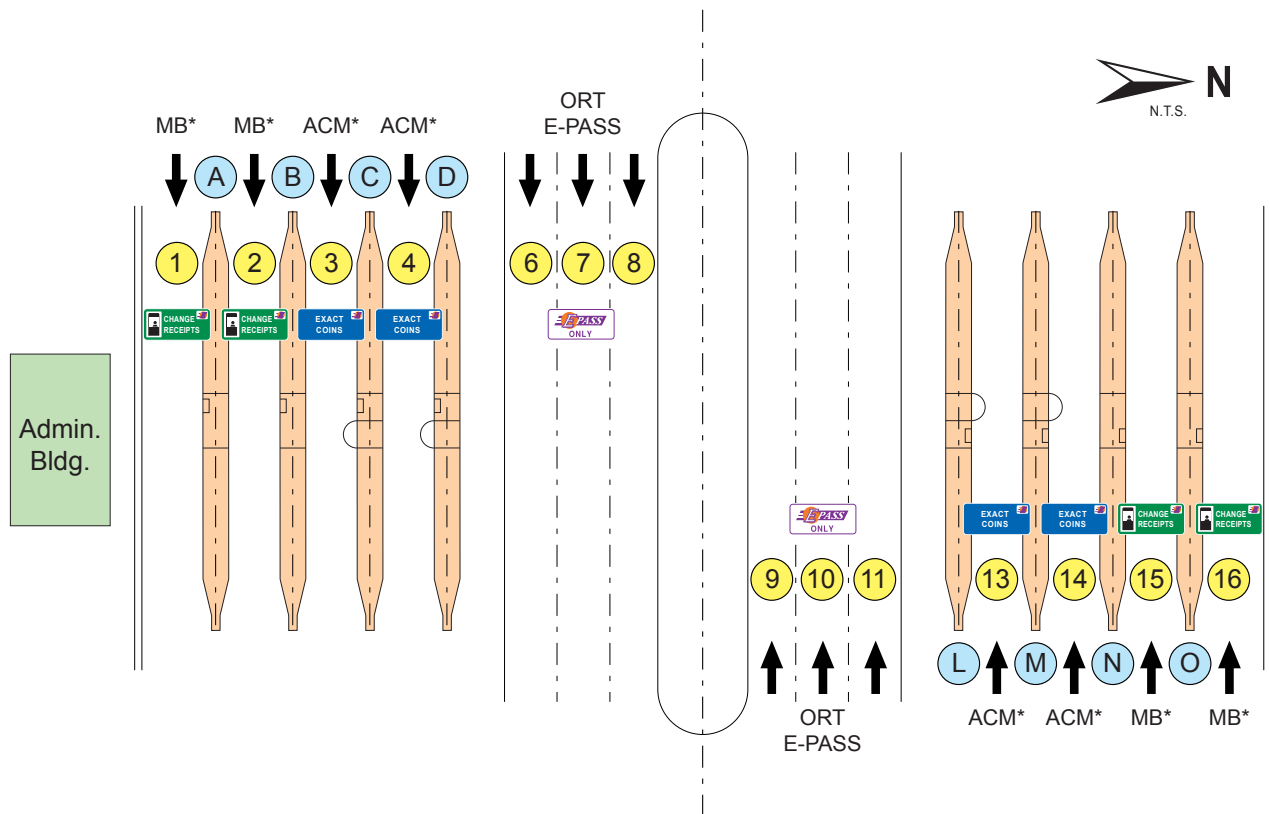

HISTORIC TRAFFIC - A.A.W.T.

1992	11,620 (Post Toll)	2001	45,180	2010	56,680
1993	13,570	2002	49,490	2011	57,170
1994	16,650	2003	53,070	2012	56,330 (Toll Increase July 2012)
1995	18,460	2004	59,370	2013	57,750
1996	23,250	2005	59,700	2014	61,440
1997	25,830	2006	64,200	2015	69,490
1998	31,400	2007	66,820	2016	73,510
1999	34,370	2008	61,620	2017	72,200
2000	41,040	2009	59,900 (Toll Increase April 2009)	2018	84,520 (Toll Increase July 2018)

TOLL RATE STRUCTURE

	<u>E-PASS</u>	<u>CASH</u>
2 Axles	\$.86	\$ 1.00
3 Axles	\$ 1.71	\$ 2.00
4 Axles	\$ 1.99	\$ 2.25
5 Axles or more	\$ 2.57	\$ 3.00

(Toll Rates Effective July 1, 2019)

LANES OF EQUIPMENT

- 4 Manned Booths (MB) with E-PASS
- 2 Booths with Automatic Coin Machines (ACM) and E-PASS
- 4 Open Road Tolling (ORT) E-PASS
- * Changeable Message Sign

LEGEND

- ① Lane Number
- Ⓐ Island Designation



SR 408 (EAST-WEST EXPRESSWAY) Hiwassee Mainline Toll Facility

SECTION III



Approx. Scale: 1" = 200'
January 2018

Hiwassee Mainline Toll Facility

SR 408 - East-West Expressway

Fiscal Year 2018 Monthly Mainline & Ramp Toll Transactions and Revenue Summary

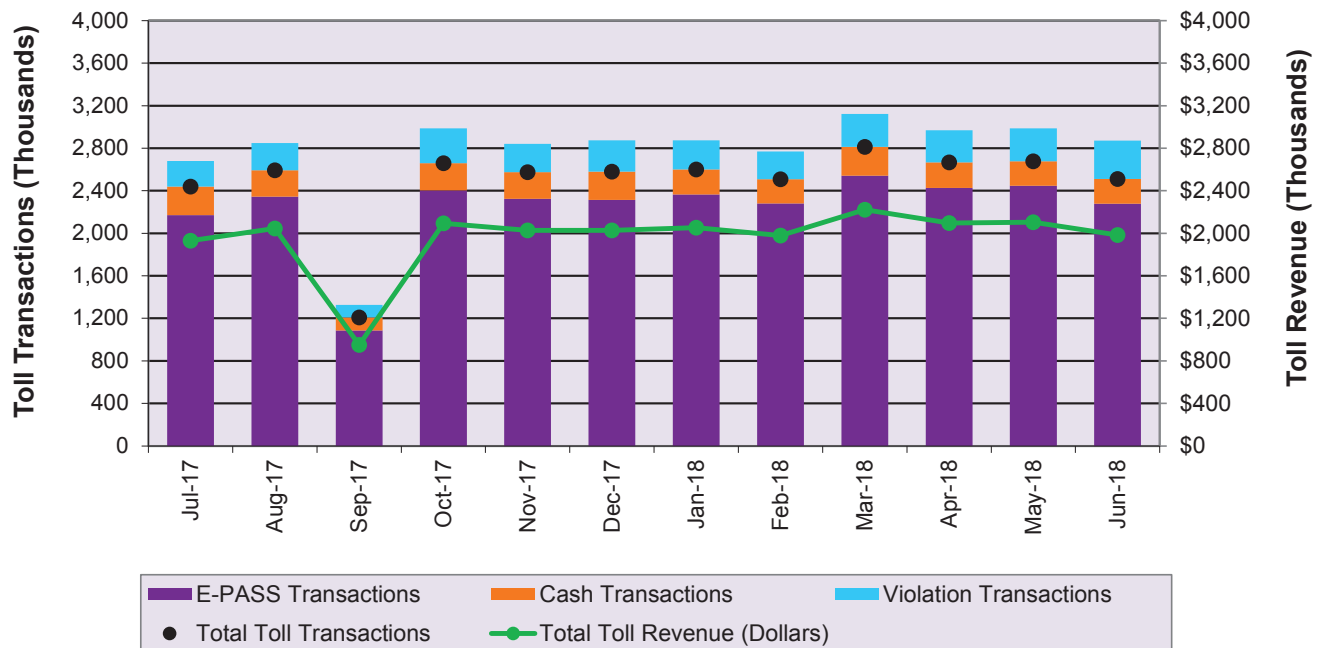

Month	FY 18 MONTHLY MAINLINE & RAMP TOLL TRANSACTIONS					Total Toll Revenue
	E-PASS	Cash	Total Revenue	Violations	Total	
July-17	2,169,531	269,462	2,438,993	241,850	2,680,843	\$1,929,145
August-17	2,344,602	247,954	2,592,556	257,126	2,849,682	\$2,044,961
September-17	1,085,502	122,333	1,207,835	118,580	1,326,415	\$950,497
October-17	2,403,884	256,449	2,660,333	325,126	2,985,459	\$2,094,755
November-17	2,323,830	251,907	2,575,737	265,428	2,841,165	\$2,026,674
December-17	2,314,569	265,347	2,579,916	293,056	2,872,972	\$2,026,537
January-18	2,364,646	234,635	2,599,281	273,911	2,873,192	\$2,052,615
February-18	2,281,624	226,583	2,508,207	260,063	2,768,270	\$1,978,217
March-18	2,541,603	271,435	2,813,038	308,621	3,121,659	\$2,222,547
April-18	2,426,436	239,161	2,665,597	303,220	2,968,817	\$2,096,479
May-18	2,447,954	230,242	2,678,196	307,102	2,985,298	\$2,105,061
June-18	2,277,852	233,000	2,510,852	361,006	2,871,858	\$1,984,984
Yearly Totals	26,982,033	2,848,508	29,830,541	3,315,089	33,145,630	\$23,512,472

Note: Data includes ramp toll plazas that report to the Hiwassee Mainline Toll Plaza.

1. Cash transactions are calculated as the difference between total revenue traffic and E-PASS traffic.

2. In FY 18, all plazas had tolls suspended from September 5, 2017 to September 21, 2017 due to Hurricane Irma.



Hiwassee Mainline Toll Facility
SR 408 - East-West Expressway
Typical Daily Traffic Volumes - April 2018

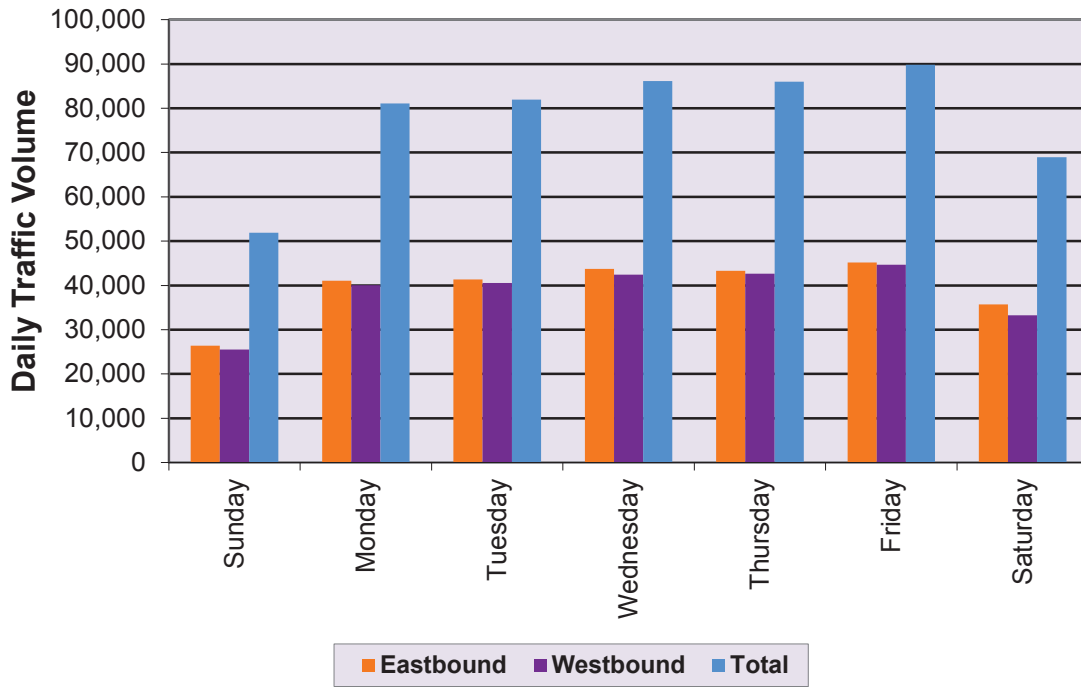

Day	Expressway Traffic Volumes		
	Eastbound	Westbound	Total
Sunday	26,356	25,505	51,861
Monday	41,047	40,058	81,105
Tuesday	41,373	40,559	81,932
Wednesday	43,731	42,430	86,160
Thursday	43,321	42,664	85,984
Friday	45,159	44,672	89,831
Saturday	35,731	33,247	68,978

Hiwassee Mainline Toll Facility SR 408 - East-West Expressway Average Five Day Hourly Traffic - April 2018

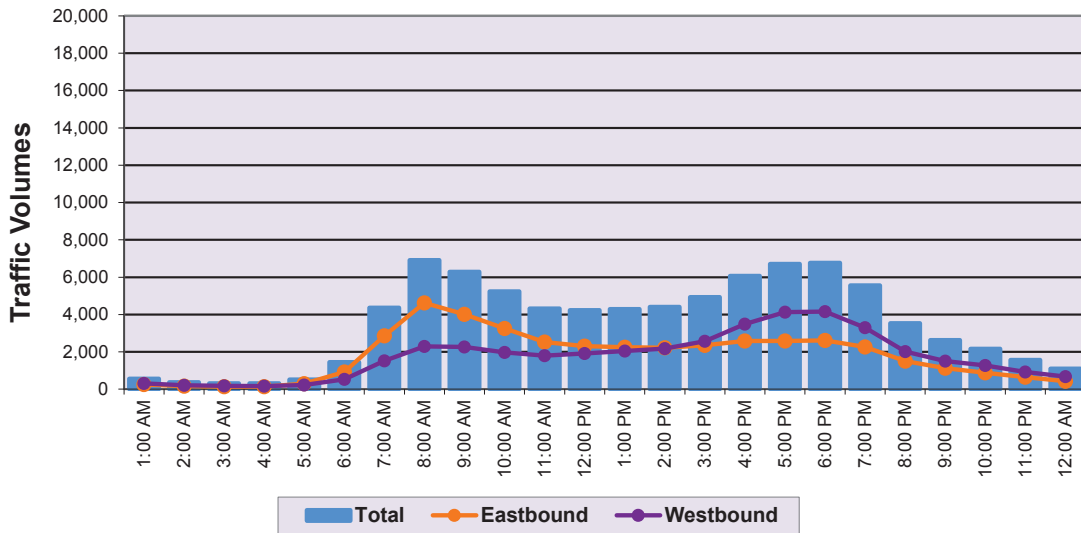

Hour Ending	Average Weekday Volumes		
	Eastbound	Westbound	Total
1:00 AM	249	303	552
2:00 AM	158	205	363
3:00 AM	128	180	308
4:00 AM	135	170	305
5:00 AM	288	225	513
6:00 AM	922	526	1,448
7:00 AM	2,853	1,514	4,367
8:00 AM	4,617	2,296	6,913
9:00 AM	4,018	2,262	6,280
10:00 AM	3,259	1,970	5,229
11:00 AM	2,529	1,795	4,324
12:00 PM	2,312	1,916	4,228

Hour Ending	Average Weekday Volumes		
	Eastbound	Westbound	Total
1:00 PM	2,253	2,038	4,291
2:00 PM	2,225	2,178	4,403
3:00 PM	2,351	2,572	4,923
4:00 PM	2,578	3,486	6,063
5:00 PM	2,584	4,127	6,712
6:00 PM	2,606	4,158	6,764
7:00 PM	2,269	3,291	5,560
8:00 PM	1,507	2,017	3,523
9:00 PM	1,127	1,506	2,634
10:00 PM	885	1,274	2,158
11:00 PM	639	922	1,561
12:00 AM	432	667	1,099

Total Eastbound	42,926
Total Westbound	41,596
Total Weekday	84,522



SR 408 (EAST-WEST EXPRESSWAY) Hiwassee Mainline Toll Facility

Hiwassee Mainline Toll Facility SR 408 - East-West Expressway Average Seven Day Hourly Traffic - April 2018

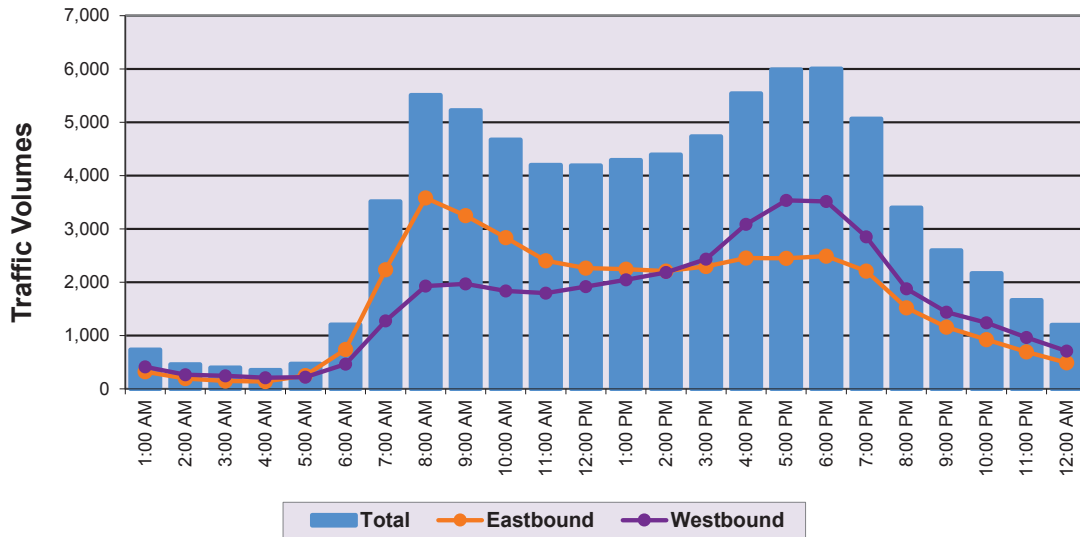

Hour Ending	Average Weekday Volumes		
	Eastbound	Westbound	Total
1:00 AM	320	417	737
2:00 AM	195	264	459
3:00 AM	149	248	397
4:00 AM	140	211	351
5:00 AM	251	219	470
6:00 AM	741	466	1,207
7:00 AM	2,237	1,276	3,513
8:00 AM	3,581	1,927	5,508
9:00 AM	3,251	1,972	5,223
10:00 AM	2,839	1,835	4,674
11:00 AM	2,404	1,795	4,199
12:00 PM	2,267	1,921	4,188

Hour Ending	Average Weekday Volumes		
	Eastbound	Westbound	Total
1:00 PM	2,244	2,048	4,292
2:00 PM	2,211	2,183	4,394
3:00 PM	2,298	2,435	4,734
4:00 PM	2,454	3,087	5,541
5:00 PM	2,451	3,538	5,989
6:00 PM	2,491	3,515	6,006
7:00 PM	2,211	2,853	5,065
8:00 PM	1,522	1,878	3,399
9:00 PM	1,158	1,441	2,599
10:00 PM	926	1,242	2,168
11:00 PM	697	967	1,664
12:00 AM	492	709	1,201

Total Eastbound	39,531
Total Westbound	38,448
Total Weekday	77,979



SR 408 (EAST-WEST EXPRESSWAY) Hiwassee Mainline Toll Facility

Hiwassee Mainline Toll Facility

Toll Facility Peak Hour Characteristic Summary Typical Average Weekday (Monday through Friday) - April 2018

Average Weekday Traffic Summary (unadjusted)

Average Weekday Total Traffic	84,522
Eastbound Directional Traffic	42,926
Westbound Directional Traffic	41,596

Morning Peak Hour Summary (7:00 a.m. to 8:00 a.m.)

Eastbound Directional Traffic	4,617
Westbound Directional Traffic	2,296
Total AM Peak Hour Traffic	6,913

AM Peak Hour Factor ("K") = Total Peak Hour Traffic / Average Weekday Total Traffic

AM Peak Hour Factor ("K_{am}") 8.18%

AM Peak Hour Directional Factor ("D") = Peak Directional Traffic / Total Peak Hour Traffic

AM Peak Hour Directional Factor ("D_{am}") 66.78%

Evening Peak Hour Summary (5:00 p.m. to 6:00 p.m.)

Eastbound Directional Traffic	2,606
Westbound Directional Traffic	4,158
Total PM Peak Hour Traffic	6,764

PM Peak Hour Factor ("K") = Total Peak Hour Traffic / Average Weekday Total Traffic

PM Peak Hour Factor ("K_{pm}") 8.00%

PM Peak Hour Directional Factor ("D") = Peak Directional Traffic / Total Peak Hour Traffic

PM Peak Hour Directional Factor ("D_{pm}") 61.47%

Hiwassee Mainline Toll Facility

Toll Transaction Summary

Typical Average Weekday (Monday through Friday) - April 2018

Average Weekday Summary

Direction of Travel	E-PASS (AVI)		ACM (Coin)		Manual (Cash)		Total	
	Volume	% Usage	Volume	% Usage	Volume	% Usage	Traffic	% Usage
Eastbound	33,208	92%	537	1%	2,371	7%	36,116	100%
Westbound	32,732	93%	481	1%	2,093	6%	35,305	100%

Morning Peak Hour Summary (7:00 a.m. to 8:00 a.m.)

Direction of Travel	E-PASS (AVI)		ACM (Coin)		Manual (Cash)		Total	
	Volume	% Usage	Volume	% Usage	Volume	% Usage	Traffic	% Usage
Eastbound	3,913	96%	23	1%	120	3%	4,056	100%
Westbound	1,772	92%	27	1%	121	6%	1,920	100%

Evening Peak Hour Summary (5:00 p.m. to 6:00 p.m.)

Direction of Travel	E-PASS (AVI)		ACM (Coin)		Manual (Cash)		Total	
	Volume	% Usage	Volume	% Usage	Volume	% Usage	Traffic	% Usage
Eastbound	1,947	91%	39	2%	164	8%	2,150	100%
Westbound	3,453	95%	34	1%	148	4%	3,636	100%

Hiwassee Mainline Toll Facility
SR 408 - East-West Expressway
Historical & Existing Total Revenue Transactions Statistics

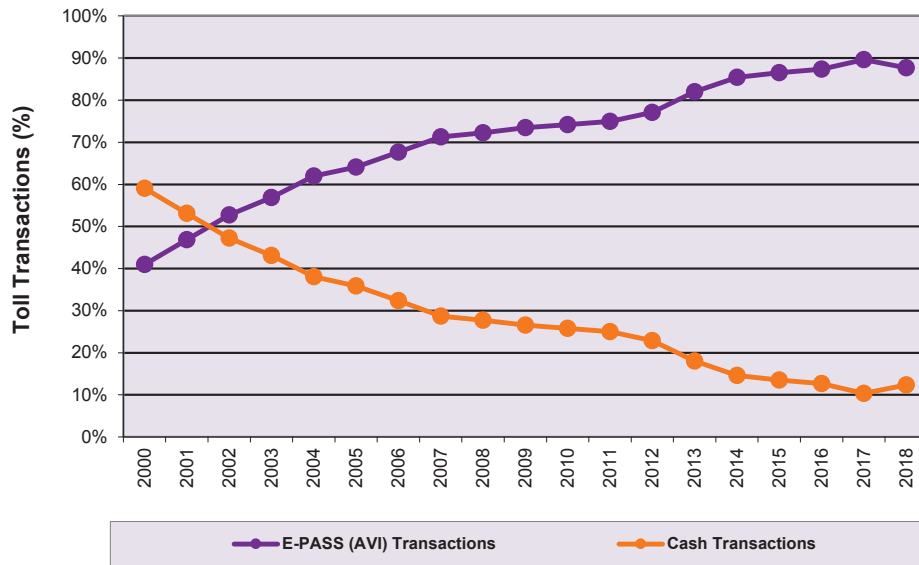

Year	Yearly Revenue Transaction		% Violations ⁽²⁾ (Percent of Total Transactions)
	% E-PASS (AVI) Transactions	% Cash Transactions	
2000	41.0%	59.0%	2.2%
2001	46.9%	53.1%	1.9%
2002	52.7%	47.3%	2.1%
2003	56.9%	43.1%	1.2%
2004	61.9%	38.1%	1.4%
2005	64.1%	35.9%	1.5%
2006	67.6%	32.4%	2.8%
2007	71.3%	28.7%	2.6%
2008	72.3%	27.7%	2.4%
2009	73.5%	26.5%	2.8%
2010	74.2%	25.8%	3.0%
2011	75.0%	25.0%	3.0%
2012	77.1%	22.9%	3.2%
2013	82.0%	18.0%	3.7%
2014	85.4%	14.6%	4.6%
2015	86.5%	13.5%	5.4%
2016	87.3%	12.7%	6.2%
2017	89.6%	10.4%	8.8%
2018	87.7%	12.3%	12.9%

1. In FY 18, all plazas had tolls suspended from September 5, 2017 to September 21, 2017 due to Hurricane Irma.

2. Calculated as percentage of Total Transactions, which is equal to Revenue Transactions plus Violations.



Pine Hills Mainline Toll Facility (East-West Expressway)



2018 Traffic Data and Statistics Manual
CENTRAL FLORIDA EXPRESSWAY AUTHORITY

OSCEOLA

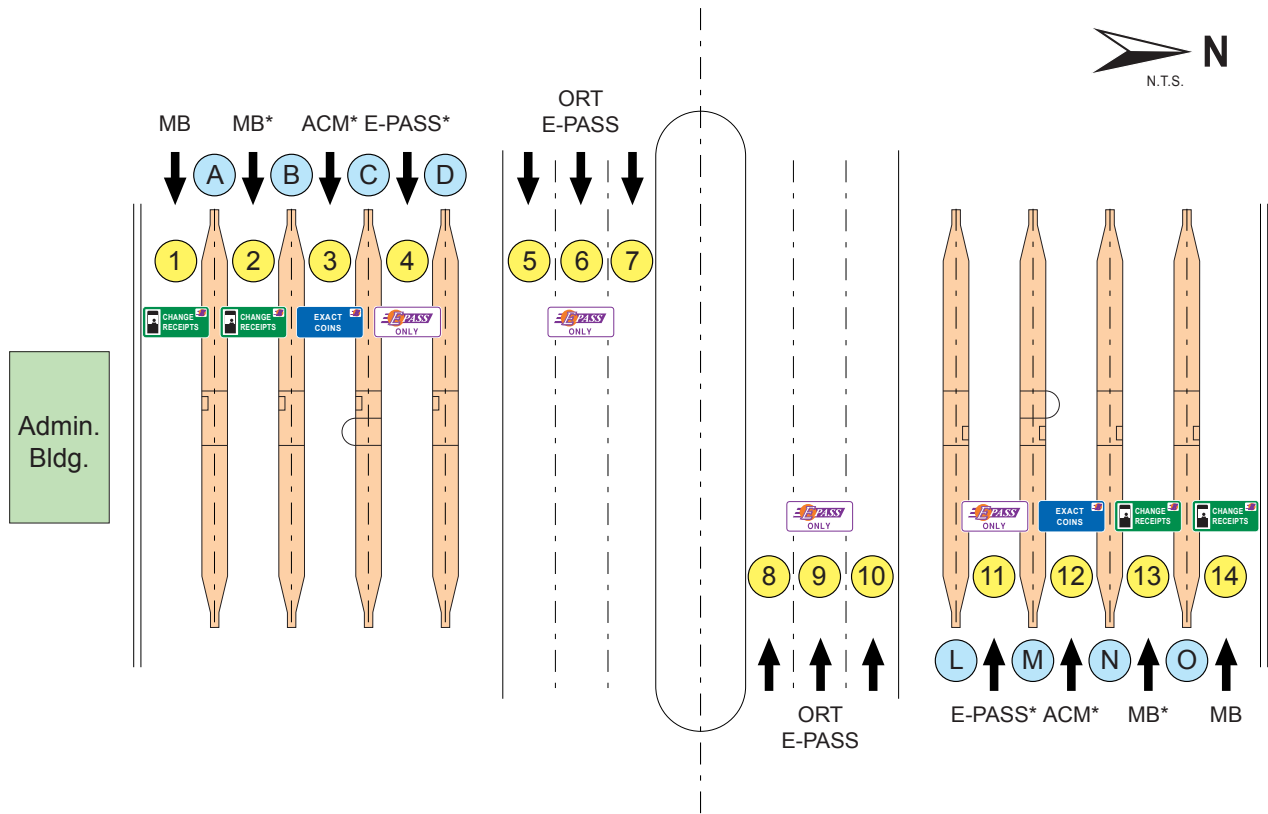

HISTORIC TRAFFIC - A.A.W.T.

2006	78,660	2011	72,070	2016	89,080
2007	82,710	2012	71,190 <i>(Toll Increase July 2012)</i>	2017	94,910
2008	77,800	2013	72,020	2018	100,740 <i>(Toll Increase July 2018)</i>
2009	69,800 <i>(Toll Increase April 2009)</i>	2014	77,210		
2010	71,150	2015	85,210		

TOLL RATE STRUCTURE

	<u>E-PASS</u>	<u>CASH</u>
2 Axles	\$ 1.13	\$ 1.25
3 Axles	\$ 1.71	\$ 2.00
4 Axles	\$ 1.99	\$ 2.25
5 Axles or more	\$ 2.57	\$ 3.00

(Toll Rates Effective July 1, 2019)

LANES OF EQUIPMENT

- 4 Manned Booths (MB) with E-PASS
- 2 Booths with Automatic Coin Machines (ACM) and E-PASS
- 2 Booths with Dedicated E-PASS
- 6 Open Road Tolling (ORT) E-PASS
- * Changeable Message Sign

LEGEND

- ① Lane Number
- Ⓐ Island Designation



**SR 408 (EAST-WEST EXPRESSWAY)
Pine Hills Mainline Toll Facility**



Approx. Scale: 1" = 200'
January 2018

Pine Hills Mainline Toll Facility

SR 408 - East-West Expressway

Fiscal Year 2018 Monthly Mainline & Ramp Toll Transactions and Revenue Summary

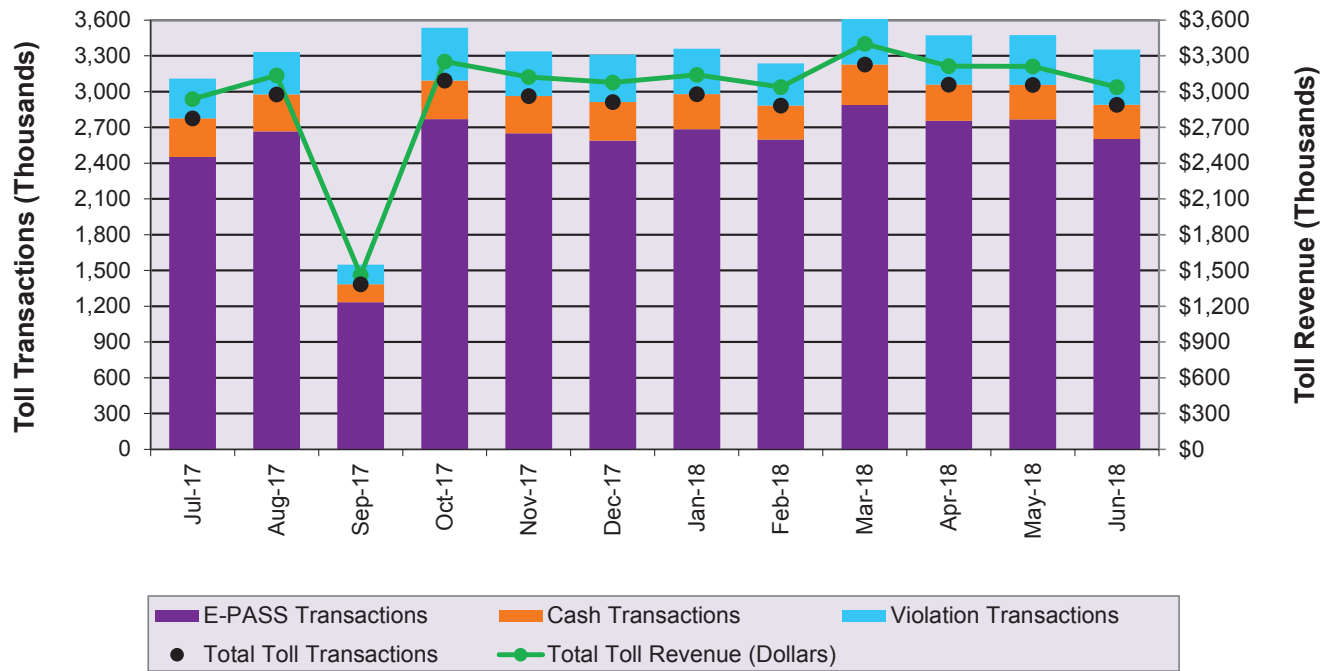

Month	FY 18 MONTHLY MAINLINE & RAMP TOLL TRANSACTIONS					Total Toll Revenue
	E-PASS	Cash	Total Revenue	Violations	Total	
July-17	2,452,377	324,478	2,776,855	332,471	3,109,326	\$2,937,090
August-17	2,666,892	308,582	2,975,474	356,865	3,332,339	\$3,136,394
September-17	1,232,841	150,543	1,383,384	164,407	1,547,791	\$1,462,401
October-17	2,769,754	323,060	3,092,814	442,607	3,535,421	\$3,251,660
November-17	2,650,216	313,305	2,963,521	374,088	3,337,609	\$3,122,244
December-17	2,588,086	324,956	2,913,042	396,279	3,309,321	\$3,076,073
January-18	2,684,449	294,630	2,979,079	381,327	3,360,406	\$3,140,728
February-18	2,598,492	285,347	2,883,839	352,794	3,236,633	\$3,039,136
March-18	2,888,684	339,497	3,228,181	415,543	3,643,724	\$3,400,728
April-18	2,755,600	304,210	3,059,810	411,058	3,470,868	\$3,214,019
May-18	2,765,625	290,007	3,055,632	417,611	3,473,243	\$3,210,923
June-18	2,601,742	287,066	2,888,808	463,211	3,352,019	\$3,038,723
Yearly Totals	30,654,758	3,545,681	34,200,439	4,508,261	38,708,700	\$36,030,119

Note: Data includes ramp toll plazas that report to the Pine Hills Mainline Toll Plaza.

1. Cash transactions are calculated as the difference between total revenue traffic and E-PASS traffic.

2. In FY 18, all plazas had tolls suspended from September 5, 2017 to September 21, 2017 due to Hurricane Irma.



SR 408 (EAST-WEST EXPRESSWAY) Pine Hills Mainline Toll Facility

Pine Hills Mainline Toll Facility
SR 408 - East-West Expressway
 Typical Daily Traffic Volumes - April 2018

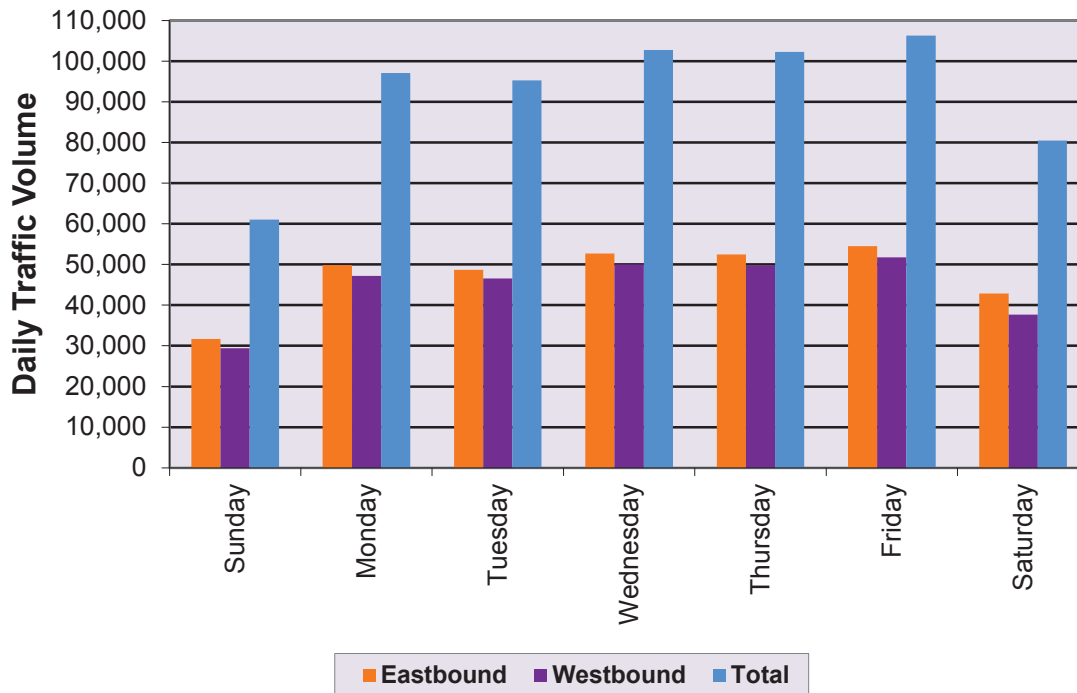

Day	Expressway Traffic Volumes		
	Eastbound	Westbound	Total
Sunday	31,653	29,438	61,091
Monday	49,841	47,229	97,070
Tuesday	48,706	46,561	95,267
Wednesday	52,741	50,004	102,745
Thursday	52,509	49,788	102,297
Friday	54,517	51,789	106,306
Saturday	42,840	37,698	80,538

Pine Hills Mainline Toll Facility
SR 408 - East-West Expressway
Average Five Day Hourly Traffic - April 2018

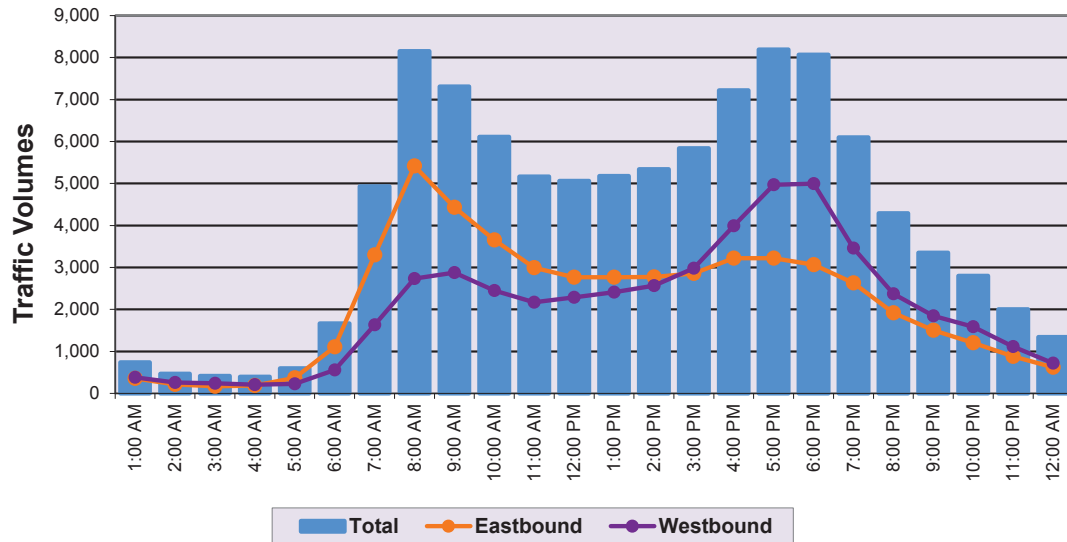

Hour Ending	Average Weekday Volumes		
	Eastbound	Westbound	Total
1:00 AM	358	381	740
2:00 AM	213	258	471
3:00 AM	173	244	416
4:00 AM	190	207	397
5:00 AM	368	229	597
6:00 AM	1,111	558	1,669
7:00 AM	3,301	1,632	4,933
8:00 AM	5,416	2,738	8,154
9:00 AM	4,432	2,878	7,310
10:00 AM	3,657	2,452	6,110
11:00 AM	2,994	2,171	5,165
12:00 PM	2,771	2,289	5,060

Hour Ending	Average Weekday Volumes		
	Eastbound	Westbound	Total
1:00 PM	2,769	2,410	5,179
2:00 PM	2,775	2,567	5,342
3:00 PM	2,856	2,985	5,841
4:00 PM	3,224	3,994	7,219
5:00 PM	3,220	4,969	8,189
6:00 PM	3,068	4,998	8,066
7:00 PM	2,633	3,464	6,097
8:00 PM	1,918	2,372	4,290
9:00 PM	1,501	1,848	3,350
10:00 PM	1,207	1,591	2,797
11:00 PM	883	1,118	2,001
12:00 AM	625	721	1,345

Total Eastbound	51,663
Total Westbound	49,074
Total Weekday	100,737



Pine Hills Mainline Toll Facility
SR 408 - East-West Expressway
Average Seven Day Hourly Traffic - April 2018

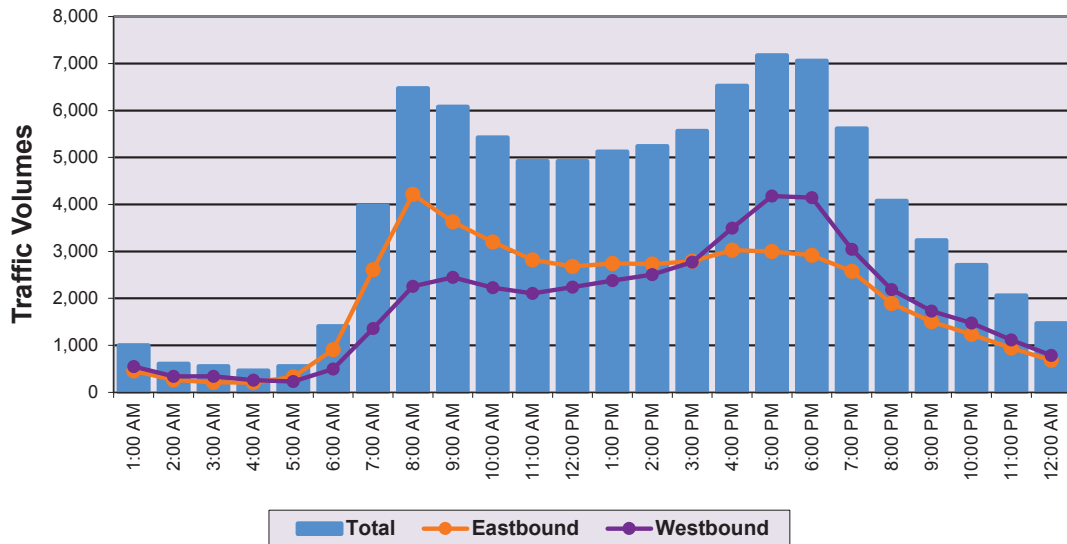

Hour Ending	Average Weekday Volumes		
	Eastbound	Westbound	Total
1:00 AM	453	545	997
2:00 AM	266	341	606
3:00 AM	212	341	553
4:00 AM	204	258	462
5:00 AM	325	228	553
6:00 AM	909	494	1,402
7:00 AM	2,610	1,359	3,970
8:00 AM	4,212	2,258	6,470
9:00 AM	3,631	2,446	6,077
10:00 AM	3,197	2,225	5,422
11:00 AM	2,817	2,104	4,920
12:00 PM	2,677	2,241	4,919

Hour Ending	Average Weekday Volumes		
	Eastbound	Westbound	Total
1:00 PM	2,744	2,378	5,122
2:00 PM	2,733	2,506	5,240
3:00 PM	2,789	2,773	5,562
4:00 PM	3,028	3,494	6,522
5:00 PM	2,995	4,177	7,171
6:00 PM	2,918	4,143	7,060
7:00 PM	2,572	3,042	5,614
8:00 PM	1,892	2,186	4,077
9:00 PM	1,505	1,732	3,237
10:00 PM	1,229	1,477	2,705
11:00 PM	944	1,116	2,060
12:00 AM	683	784	1,467

Total Eastbound	47,544
Total Westbound	44,644
Total Weekday	92,187



Pine Hills Mainline Toll Facility

Toll Facility Peak Hour Characteristic Summary Typical Average Weekday (Monday through Friday) - April 2018

Average Weekday Traffic Summary (unadjusted)

Average Weekday Total Traffic	100,737
Eastbound Directional Traffic	51,663
Westbound Directional Traffic	49,074

Morning Peak Hour Summary (7:00 a.m. to 8:00 a.m.)

Eastbound Directional Traffic	5,416
Westbound Directional Traffic	2,738
Total AM Peak Hour Traffic	8,154

AM Peak Hour Factor ("K") = Total Peak Hour Traffic / Average Weekday Total Traffic

AM Peak Hour Factor ("K_{am}") 8.09%

AM Peak Hour Directional Factor ("D") = Peak Directional Traffic / Total Peak Hour Traffic

AM Peak Hour Directional Factor ("D_{am}") 66.42%

Evening Peak Hour Summary (5:00 p.m. to 6:00 p.m.)

Eastbound Directional Traffic	3,068
Westbound Directional Traffic	4,998
Total PM Peak Hour Traffic	8,066

PM Peak Hour Factor ("K") = Total Peak Hour Traffic / Average Weekday Total Traffic

PM Peak Hour Factor ("K_{pm}") 8.01%

PM Peak Hour Directional Factor ("D") = Peak Directional Traffic / Total Peak Hour Traffic

PM Peak Hour Directional Factor ("D_{pm}") 61.96%

Pine Hills Mainline Toll Facility

Toll Transaction Summary

Typical Average Weekday (Monday through Friday) - April 2018

Average Weekday Summary

Direction of Travel	E-PASS (AVI)		ACM (Coin)		Manual (Cash)		Total	
	Volume	% Usage	Volume	% Usage	Volume	% Usage	Traffic	% Usage
Eastbound	46,815	91%	836	2%	3,425	7%	51,663	99%
Westbound	44,835	91%	778	2%	2,890	6%	49,074	99%

Morning Peak Hour Summary (7:00 a.m. to 8:00 a.m.)

Direction of Travel	E-PASS (AVI)		ACM (Coin)		Manual (Cash)		Total	
	Volume	% Usage	Volume	% Usage	Volume	% Usage	Traffic	% Usage
Eastbound	5,064	94%	52	1%	237	4%	5,416	99%
Westbound	2,738	100%	33	1%	134	5%	2,738	106%

Evening Peak Hour Summary (5:00 p.m. to 6:00 p.m.)

Direction of Travel	E-PASS (AVI)		ACM (Coin)		Manual (Cash)		Total	
	Volume	% Usage	Volume	% Usage	Volume	% Usage	Traffic	% Usage
Eastbound	2,800	91%	45	1%	196	6%	3,068	99%
Westbound	4,644	93%	54	1%	243	5%	4,998	99%



Pine Hills Mainline Toll Facility
SR 408 - East-West Expressway
Historical & Existing Total Revenue Transactions Statistics

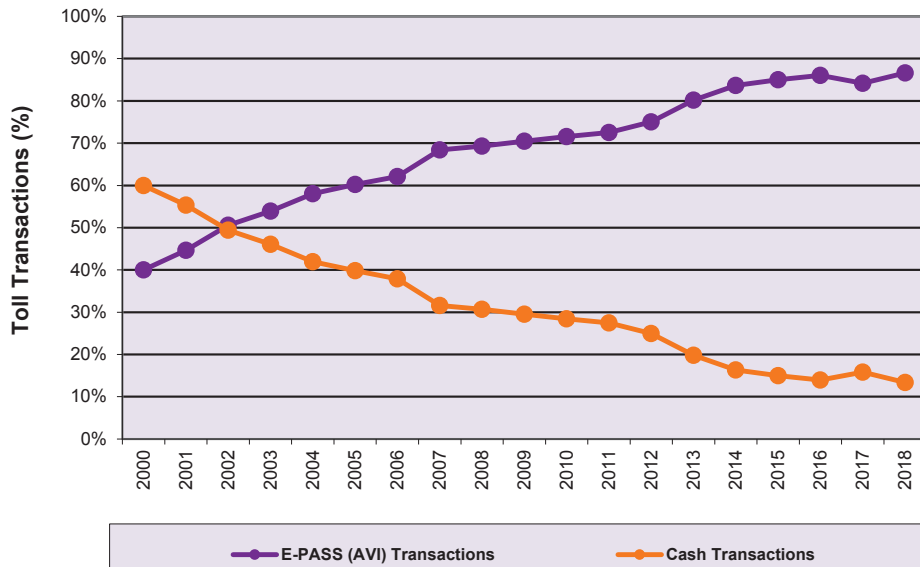

Year	Yearly Revenue Transaction		% Violations ⁽²⁾ (Percent of Total Transactions)
	% E-PASS (AVI) Transactions	% Cash Transactions	
2000	40.0%	60.0%	3.0%
2001	44.7%	55.3%	2.6%
2002	50.6%	49.4%	2.1%
2003	53.9%	46.1%	2.1%
2004	58.1%	41.9%	2.1%
2005	60.2%	39.8%	2.4%
2006	62.1%	37.9%	2.7%
2007	68.4%	31.6%	4.5%
2008	69.3%	30.7%	3.6%
2009	70.5%	29.5%	3.7%
2010	71.6%	28.4%	4.0%
2011	72.5%	27.5%	4.0%
2012	75.0%	25.0%	4.2%
2013	80.2%	19.8%	4.7%
2014	83.7%	16.3%	5.7%
2015	85.0%	15.0%	6.6%
2016	86.0%	14.0%	7.6%
2017	84.2%	15.8%	9.2%
2018	86.6%	13.4%	14.6%

1. In FY 18, all plazas had tolls suspended from September 5, 2017 to September 21, 2017 due to Hurricane Irma.

2. Calculated as percentage of Total Transactions, which is equal to Revenue Transactions plus Violations.



Conway East & West Mainline Toll Facility (East-West Expressway)



2018 Traffic Data and Statistics Manual
CENTRAL FLORIDA EXPRESSWAY AUTHORITY

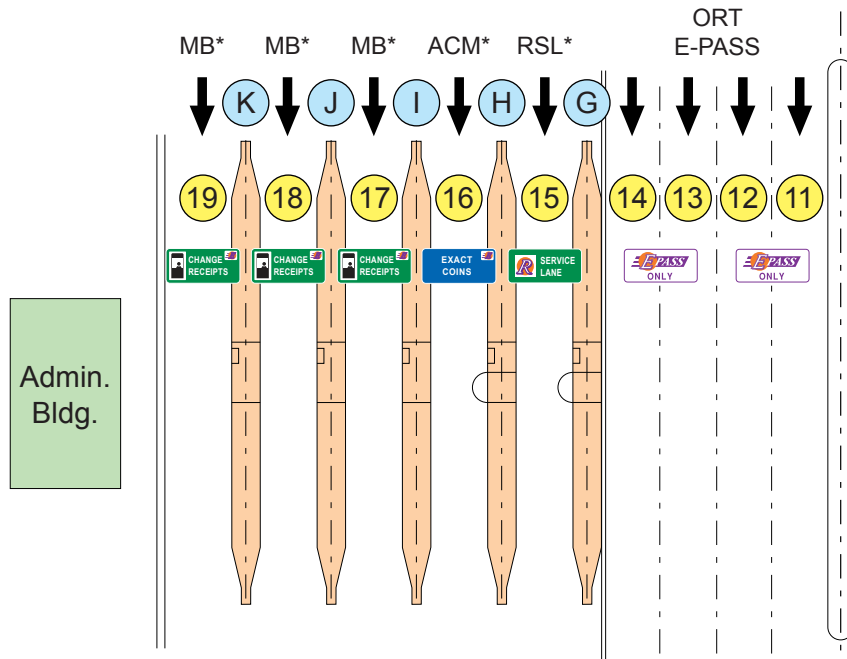

Notes: Lane 15 E-PASS Reload Lane
Lane 14 opened to traffic Q4 of 2017

** Historic traffic includes both the Conway East & West Mainline Toll Facilities.

HISTORIC TRAFFIC - A.A.W.T. **

1992	No Count (Post Toll)	2001	107,940	2010	117,830
1993	62,620	2002	110,130	2011	119,600
1994	64,650	2003	116,000	2012	117,530 (Toll Increase July 2012)
1995	73,020	2004	125,460	2013	115,530
1996	77,400	2005	123,500	2014	122,400
1997	87,810	2006	125,000	2015	132,940
1998	94,450	2007	118,100	2016	140,380
1999	98,850	2008	112,200	2017	147,220
2000	105,200	2009	112,750 (Toll Increase April 2009)	2018	151,570 (Toll Increase July 2018)

TOLL RATE STRUCTURE

	E-PASS	CASH
2 Axles	\$ 1.13	\$ 1.25
3 Axles	\$ 1.71	\$ 2.00
4 Axles	\$ 1.99	\$ 2.25
5 Axles or more	\$ 2.57	\$ 3.00

(Toll Rates Effective July 1, 2019)

LANES OF EQUIPMENT

- 3 Manned Booths (MB) with E-PASS
- 1 Booth with Automatic Coin Machines (ACM) and E-PASS
- 1 Reload Service Lane (RSL)
- 4 Open Road Tolling (ORT) E-PASS
- * Changeable Message Sign

LEGEND

- ① Lane Number
- Ⓐ Island Designation



SR 408 (EAST-WEST EXPRESSWAY) Conway East Mainline Toll Facility

SECTION III

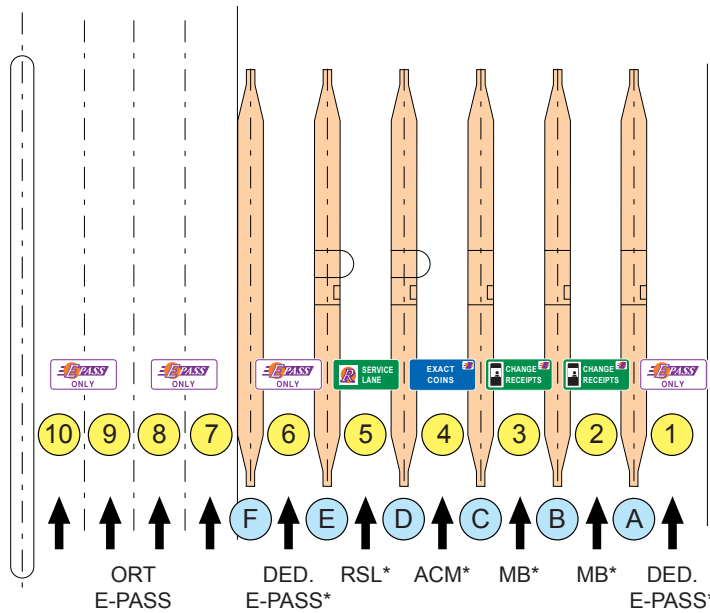

Notes: Lane 5 E-PASS Reload Lane
Lane 4 opened to traffic Q4 of 2017

** Historic traffic includes both the Conway East & West Mainline Toll Facilities.

HISTORIC TRAFFIC - A.A.W.T. **

1992	No Count (Post Toll)	2001	107,940	2010	117,830
1993	62,620	2002	110,130	2011	119,600
1994	64,650	2003	116,000	2012	117,530 (Toll Increase July 2012)
1995	73,020	2004	125,460	2013	115,530
1996	77,400	2005	123,500	2014	122,400
1997	87,810	2006	125,000	2015	132,940
1998	94,450	2007	118,100	2016	140,380
1999	98,850	2008	112,200	2017	147,220
2000	105,200	2009	112,750 (Toll Increase April 2009)	2018	151,570 (Toll Increase July 2018)

TOLL RATE STRUCTURE

	E-PASS	CASH
2 Axles	\$ 1.13	\$ 1.25
3 Axles	\$ 1.71	\$ 2.00
4 Axles	\$ 1.99	\$ 2.25
5 Axles or more	\$ 2.57	\$ 3.00

(Toll Rates Effective July 1, 2019)

LANES OF EQUIPMENT

- 2 Manned Booths (MB) with E-PASS
- 1 Booths with Automatic Coin Machines (ACM) and E-PASS
- 1 Reload Service Lane (RSL)
- 2 Dedicated E-PASS Lanes
- 4 Open Road Tolling (ORT) E-PASS
- * Changeable Message Sign

LEGEND

- ① Lane Number
- Ⓐ Island Designation



SR 408 (EAST-WEST EXPRESSWAY) Conway West Mainline Toll Facility

SECTION III



Approx. Scale: 1" = 300'
January 2018

Conway Mainline Toll Facility SR 408 - East-West Expressway

Fiscal Year 2018 Monthly Mainline & Ramp Toll Transactions and Revenue Summary

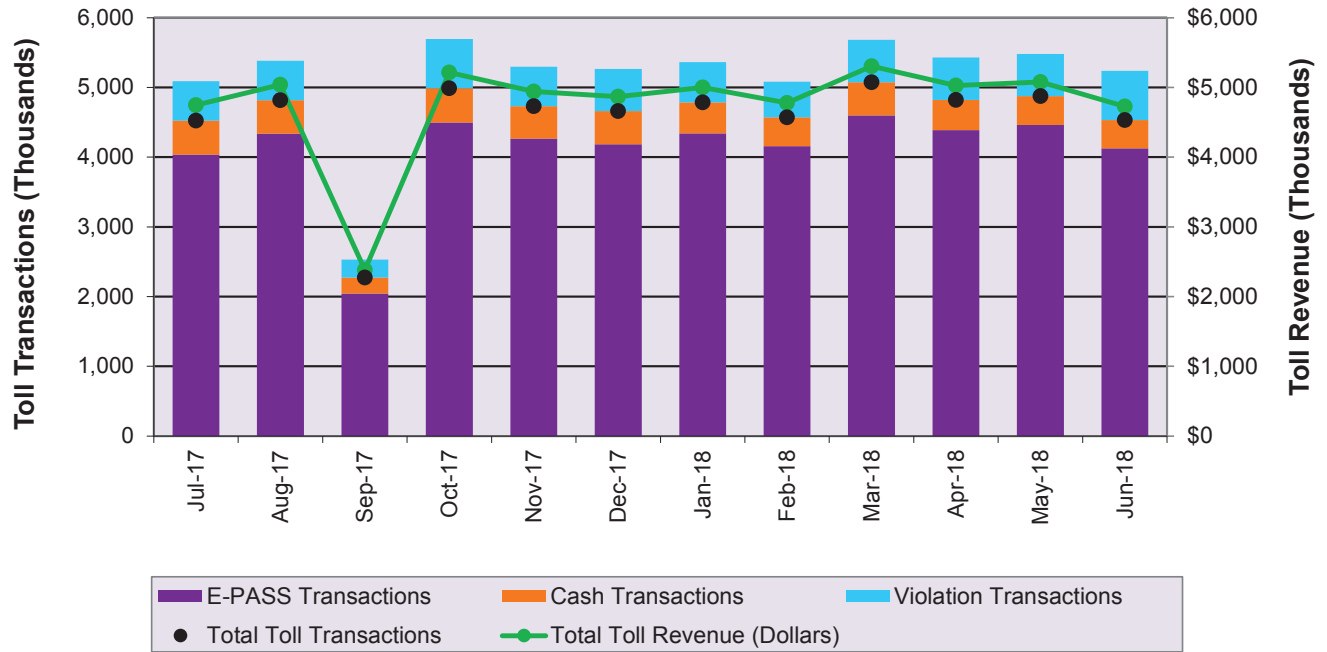

Month	FY 18 MONTHLY MAINLINE & RAMP TOLL TRANSACTIONS					Total Toll Revenue
	E-PASS	Cash	Total Revenue	Violations	Total	
July-17	4,035,296	488,823	4,524,119	567,188	5,091,307	\$4,745,330
August-17	4,338,126	479,900	4,818,026	562,337	5,380,363	\$5,038,325
September-17	2,044,357	229,347	2,273,704	257,899	2,531,603	\$2,382,770
October-17	4,498,194	490,257	4,988,451	704,386	5,692,837	\$5,215,387
November-17	4,267,367	461,460	4,728,827	567,379	5,296,206	\$4,942,355
December-17	4,182,621	478,528	4,661,149	605,352	5,266,501	\$4,866,598
January-18	4,341,772	441,787	4,783,559	577,206	5,360,765	\$4,999,786
February-18	4,157,061	414,683	4,571,744	510,565	5,082,309	\$4,775,570
March-18	4,597,081	477,256	5,074,337	609,432	5,683,769	\$5,305,063
April-18	4,388,613	431,758	4,820,371	609,562	5,429,933	\$5,025,473
May-18	4,460,247	415,807	4,876,054	603,817	5,479,871	\$5,079,598
June-18	4,125,817	405,466	4,531,283	706,458	5,237,741	\$4,725,998
Yearly Totals	49,436,552	5,215,072	54,651,624	6,881,581	61,533,205	\$57,102,253

Note: Data includes ramp toll plazas that report to the Conway Mainline Toll Plaza.

- Cash transactions are calculated as the difference between total revenue traffic and E-PASS traffic.
- In FY 18, all plazas had tolls suspended from September 5, 2017 to September 21, 2017 due to Hurricane Irma.



Conway Mainline Toll Facility
SR 408 - East-West Expressway
Typical Daily Traffic Volumes - April 2018

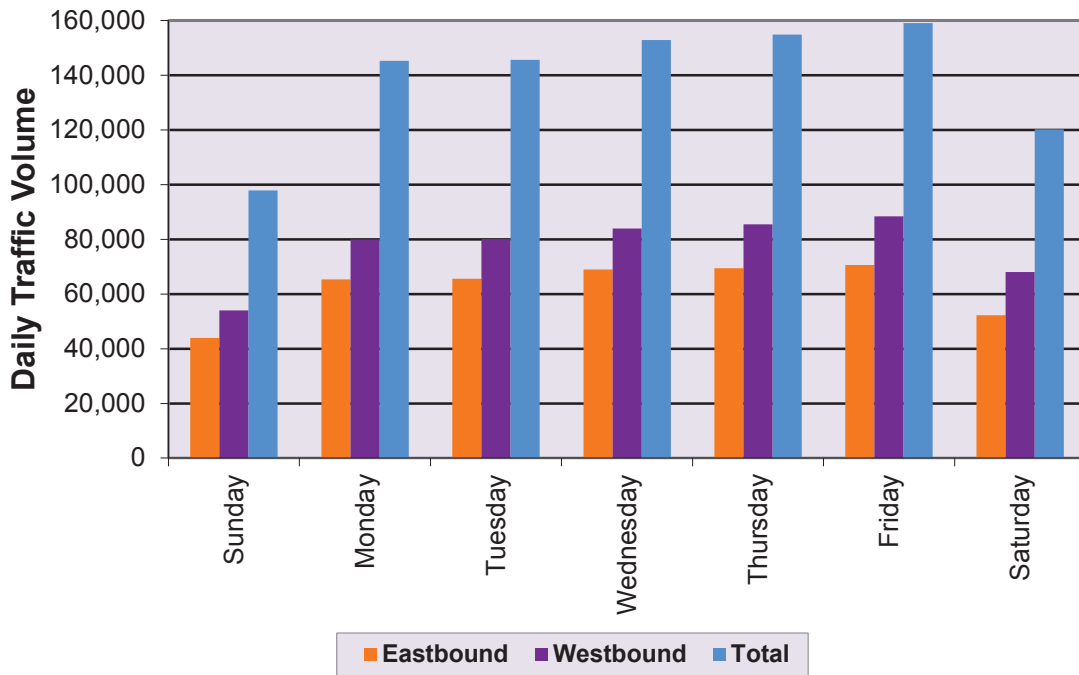

Day	Expressway Traffic Volumes		
	Eastbound	Westbound	Total
Sunday	43,902	54,041	97,943
Monday	65,348	79,997	145,344
Tuesday	65,539	80,058	145,597
Wednesday	68,932	84,018	152,950
Thursday	69,453	85,453	154,905
Friday	70,632	88,412	159,044
Saturday	52,217	68,022	120,238



Conway Mainline Toll Facility SR 408 - East-West Expressway Average Five Day Hourly Traffic - April 2018

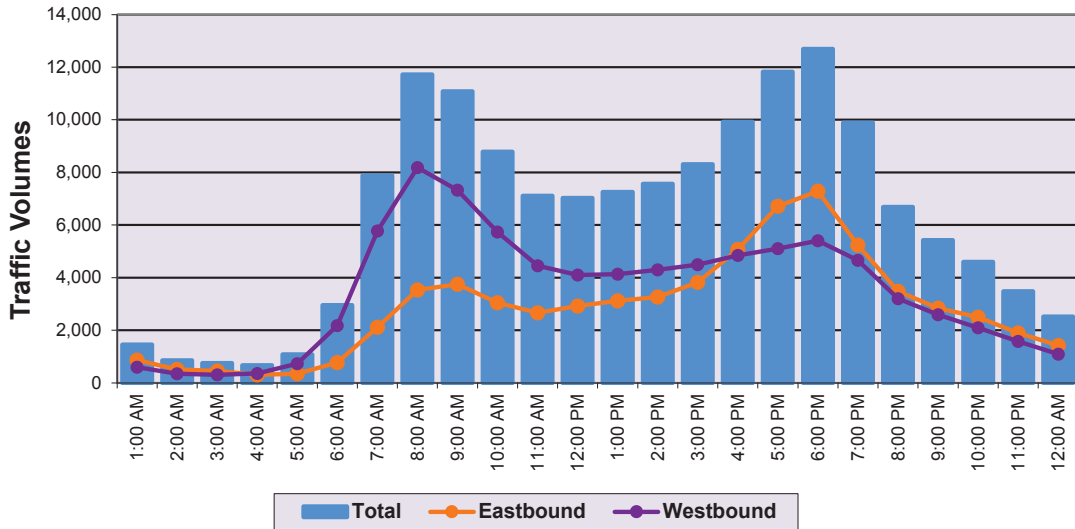

Hour Ending	Average Weekday Volumes		
	Eastbound	Westbound	Total
1:00 AM	866	592	1,459
2:00 AM	515	345	861
3:00 AM	449	307	756
4:00 AM	312	361	673
5:00 AM	351	735	1,087
6:00 AM	777	2,177	2,954
7:00 AM	2,115	5,774	7,889
8:00 AM	3,533	8,185	11,718
9:00 AM	3,754	7,327	11,080
10:00 AM	3,046	5,737	8,783
11:00 AM	2,661	4,450	7,112
12:00 PM	2,928	4,098	7,026

Hour Ending	Average Weekday Volumes		
	Eastbound	Westbound	Total
1:00 PM	3,122	4,131	7,253
2:00 PM	3,267	4,293	7,560
3:00 PM	3,821	4,491	8,312
4:00 PM	5,073	4,847	9,920
5:00 PM	6,721	5,103	11,824
6:00 PM	7,289	5,406	12,694
7:00 PM	5,236	4,660	9,896
8:00 PM	3,484	3,207	6,691
9:00 PM	2,837	2,589	5,427
10:00 PM	2,498	2,097	4,595
11:00 PM	1,897	1,581	3,478
12:00 AM	1,428	1,095	2,522

Total Eastbound	67,980
Total Westbound	83,587
Total Weekday	151,568



SR 408 (EAST-WEST EXPRESSWAY) Conway East & West Mainline Toll Facility

Conway Mainline Toll Facility
SR 408 - East-West Expressway
Average Seven Day Hourly Traffic - April 2018

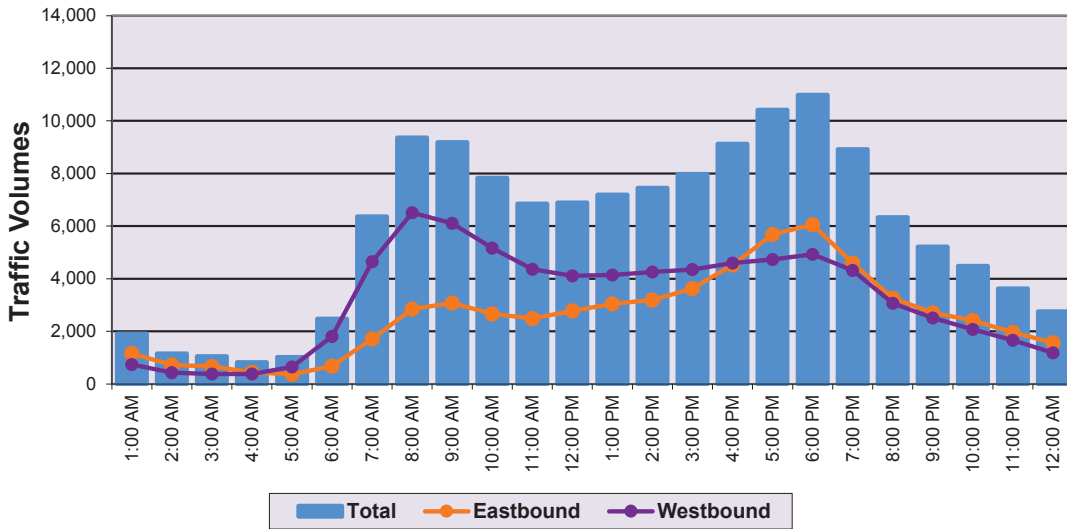

Hour Ending	Average Weekday Volumes		
	Eastbound	Westbound	Total
1:00 AM	1,164	745	1,909
2:00 AM	725	434	1,159
3:00 AM	670	385	1,054
4:00 AM	445	378	822
5:00 AM	365	652	1,017
6:00 AM	676	1,803	2,479
7:00 AM	1,716	4,645	6,361
8:00 AM	2,854	6,514	9,368
9:00 AM	3,083	6,109	9,192
10:00 AM	2,662	5,172	7,834
11:00 AM	2,494	4,361	6,855
12:00 PM	2,775	4,114	6,889

Hour Ending	Average Weekday Volumes		
	Eastbound	Westbound	Total
1:00 PM	3,050	4,140	7,190
2:00 PM	3,194	4,262	7,455
3:00 PM	3,627	4,350	7,976
4:00 PM	4,529	4,603	9,131
5:00 PM	5,687	4,728	10,415
6:00 PM	6,058	4,934	10,992
7:00 PM	4,593	4,321	8,915
8:00 PM	3,269	3,065	6,334
9:00 PM	2,709	2,507	5,216
10:00 PM	2,414	2,072	4,486
11:00 PM	1,964	1,663	3,627
12:00 AM	1,567	1,189	2,755

Total Eastbound	62,289
Total Westbound	77,143
Total Weekday	139,431



SR 408 (EAST-WEST EXPRESSWAY)
Conway East & West Mainline Toll Facility

Conway Mainline Toll Facility

Toll Facility Peak Hour Characteristic Summary Typical Average Weekday (Monday through Friday) - April 2018

Average Weekday Traffic Summary (unadjusted)

Average Weekday Total Traffic	151,568
Eastbound Directional Traffic	67,980
Westbound Directional Traffic	83,587

Morning Peak Hour Summary (7:00 a.m. to 8:00 a.m.)

Eastbound Directional Traffic	3,533
Westbound Directional Traffic	8,185
Total AM Peak Hour Traffic	11,718

AM Peak Hour Factor ("K") = Total Peak Hour Traffic / Average Weekday Total Traffic

AM Peak Hour Factor ("K_{am}") 7.73%

AM Peak Hour Directional Factor ("D") = Peak Directional Traffic / Total Peak Hour Traffic

AM Peak Hour Directional Factor ("D_{am}") 69.85%

Evening Peak Hour Summary (5:00 p.m. to 6:00 p.m.)

Eastbound Directional Traffic	7,289
Westbound Directional Traffic	5,406
Total PM Peak Hour Traffic	12,694

PM Peak Hour Factor ("K") = Total Peak Hour Traffic / Average Weekday Total Traffic

PM Peak Hour Factor ("K_{pm}") 8.38%

PM Peak Hour Directional Factor ("D") = Peak Directional Traffic / Total Peak Hour Traffic

PM Peak Hour Directional Factor ("D_{pm}") 57.42%

Conway Mainline Toll Facility

Toll Transaction Summary

Typical Average Weekday (Monday through Friday) - April 2018

Average Weekday Summary

Direction of Travel	E-PASS (AVI)		ACM (Coin)		Manual (Cash)		Total	
	Volume	% Usage	Volume	% Usage	Volume	% Usage	Traffic	% Usage
Eastbound	61,871	92%	767	1%	4,661	7%	67,299	100%
Westbound	75,216	91%	870	1%	6,572	8%	82,658	100%

Morning Peak Hour Summary (7:00 a.m. to 8:00 a.m.)

Direction of Travel	E-PASS (AVI)		ACM (Coin)		Manual (Cash)		Total	
	Volume	% Usage	Volume	% Usage	Volume	% Usage	Traffic	% Usage
Eastbound	3,255	93%	36	1%	214	6%	3,505	100%
Westbound	7,589	94%	5	0%	516	6%	8,110	100%

Evening Peak Hour Summary (5:00 p.m. to 6:00 p.m.)

Direction of Travel	E-PASS (AVI)		ACM (Coin)		Manual (Cash)		Total	
	Volume	% Usage	Volume	% Usage	Volume	% Usage	Traffic	% Usage
Eastbound	6,755	93%	57	1%	414	6%	7,227	100%
Westbound	4,881	91%	67	1%	399	7%	5,347	100%



**Conway Mainline Toll Facility
SR 408 - East West Expressway
Historical & Existing Total Transactions Statistics**

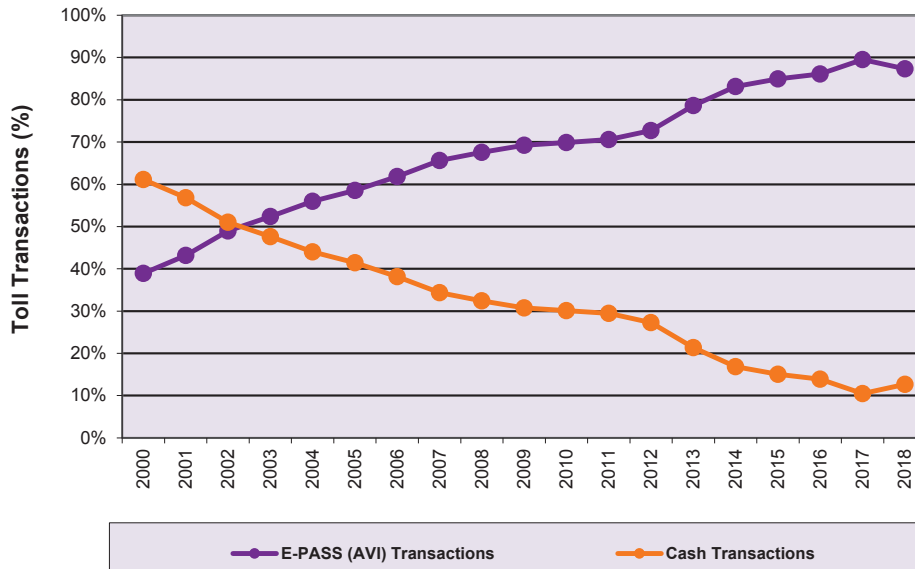

Year	Yearly Revenue Transaction		% Violations ⁽²⁾ (Percent of Total Transactions)
	% E-PASS (AVI) Transactions	% Cash Transactions	
2000	38.9%	61.1%	3.0%
2001	43.2%	56.8%	2.5%
2002	49.0%	51.0%	1.9%
2003	52.4%	47.6%	1.9%
2004	56.0%	44.0%	2.0%
2005	58.6%	41.4%	2.5%
2006	61.8%	38.2%	2.4%
2007	65.6%	34.4%	2.7%
2008	67.6%	32.4%	3.3%
2009	69.3%	30.7%	4.5%
2010	69.9%	30.1%	4.9%
2011	70.6%	29.4%	4.8%
2012	72.7%	27.3%	4.7%
2013	78.7%	21.3%	5.2%
2014	83.2%	16.8%	6.3%
2015	84.9%	15.1%	7.2%
2016	86.1%	13.9%	8.3%
2017	89.5%	10.5%	10.7%
2018	87.3%	12.7%	14.0%

1. In FY 18, all plazas had tolls suspended from September 5, 2017 to September 21, 2017 due to Hurricane Irma.
2. Calculated as percentage of Total Transactions, which is equal to Revenue Transactions plus Violations.



**SR 408 (EAST-WEST EXPRESSWAY)
Conway East & West Mainline Toll Facility**

Dean Mainline Toll Facility (East-West Expressway)



2018 Traffic Data and Statistics Manual
CENTRAL FLORIDA EXPRESSWAY AUTHORITY

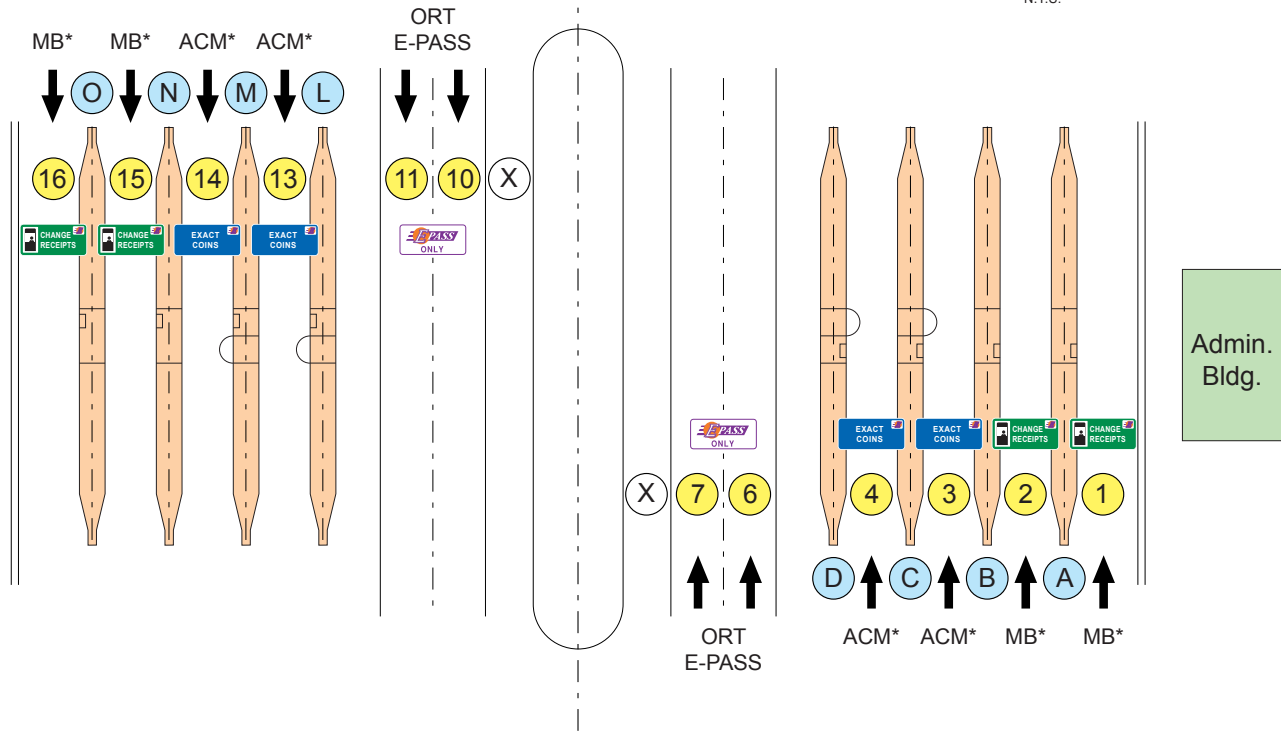

HISTORIC TRAFFIC - A.A.W.T.

1992	13,680 (Post Toll)	2001	50,100	2010	68,130
1993	14,740	2002	53,760	2011	66,670
1994	16,380	2003	57,600	2012	67,200 (Toll Increase July 2012)
1995	20,410	2004	63,930	2013	67,320
1996	22,770	2005	65,900	2014	71,110
1997	26,360	2006	69,900	2015	74,180
1998	31,630	2007	70,100	2016	79,580
1999	38,530	2008	66,000	2017	83,570
2000	45,800	2009	65,900 (Toll Increase April 2009)	2018	85,430 (Toll Increase July 2018)

TOLL RATE STRUCTURE

	E-PASS	CASH
2 Axles	\$.86	\$ 1.00
3 Axles	\$ 1.71	\$ 2.00
4 Axles	\$ 1.99	\$ 2.25
5 Axles or more	\$ 2.57	\$ 3.00

(Toll Rates Effective July 1, 2019)

LANES OF EQUIPMENT

- 4 Manned Booths (MB) with E-PASS
- 4 Booths with Automatic Coin Machines (ACM) and E-PASS
- 4 Open Road Tolling (ORT) E-PASS
- * Changeable Message Sign

LEGEND

- ① Lane Number
- Ⓐ Island Designation
- ⓧ Under Construction by Project #408-128



SR 408 (EAST-WEST EXPRESSWAY) Dean Mainline Toll Facility

SECTION III



Approx. Scale: 1" = 200'
January 2018

Dean Mainline Toll Facility
SR 408 - East-West Expressway
Fiscal Year 2018 Monthly Mainline & Ramp Toll Transactions and Revenue Summary

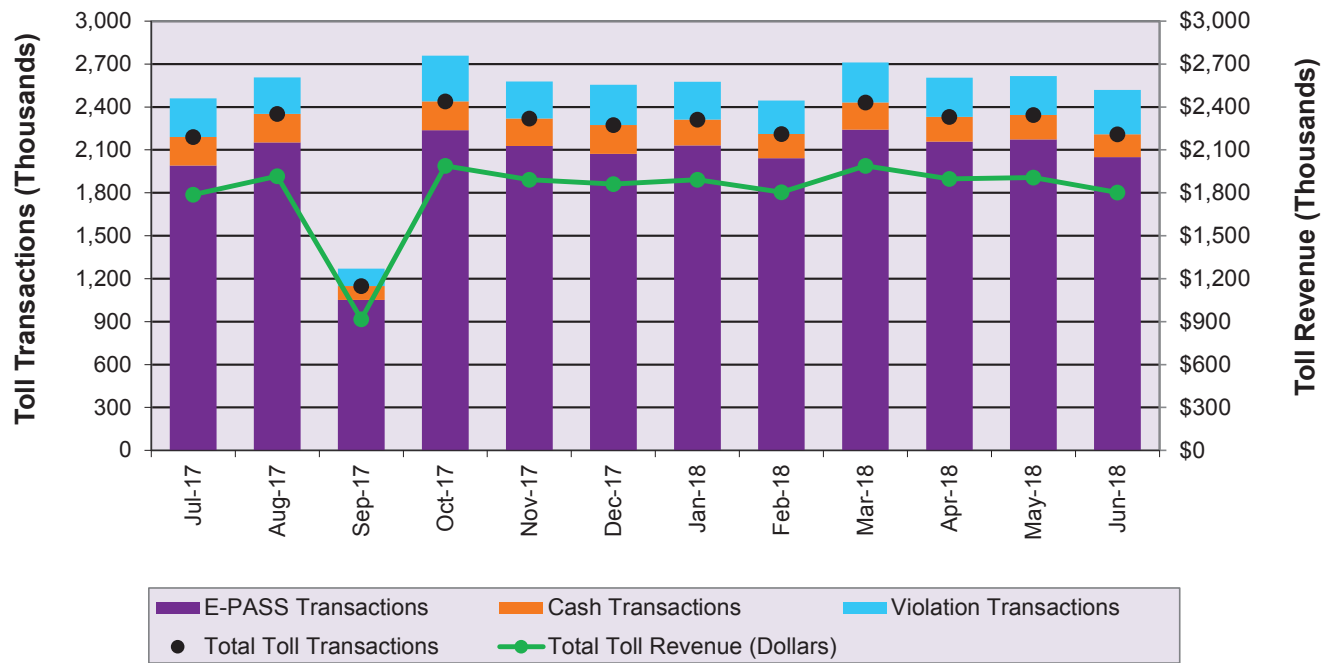

Month	FY 18 MONTHLY MAINLINE & RAMP TOLL TRANSACTIONS					Total Toll Revenue
	E-PASS	Cash	Total Revenue	Violations	Total	
July-17	1,991,057	199,105	2,190,162	269,740	2,459,902	\$1,787,735
August-17	2,151,547	199,331	2,350,878	255,523	2,606,401	\$1,916,432
September-17	1,051,112	97,072	1,148,184	121,498	1,269,682	\$916,299
October-17	2,237,850	202,098	2,439,948	319,276	2,759,224	\$1,987,946
November-17	2,127,527	191,487	2,319,014	259,225	2,578,239	\$1,892,578
December-17	2,072,893	200,608	2,273,501	280,834	2,554,335	\$1,861,804
January-18	2,132,173	180,336	2,312,509	263,671	2,576,180	\$1,890,930
February-18	2,042,046	168,195	2,210,241	235,675	2,445,916	\$1,804,830
March-18	2,241,703	190,727	2,432,430	279,297	2,711,727	\$1,988,825
April-18	2,156,978	174,478	2,331,456	273,779	2,605,235	\$1,896,647
May-18	2,173,495	170,430	2,343,925	272,581	2,616,506	\$1,906,896
June-18	2,049,815	160,364	2,210,179	308,572	2,518,751	\$1,802,721
Yearly Totals	24,428,196	2,134,231	26,562,427	3,139,671	29,702,098	\$21,653,643

Note: Data includes ramp toll plazas that report to the Dean Mainline Toll Plaza.

1. Cash transactions are calculated as the difference between total revenue traffic and E-PASS traffic.
2. In FY 18, all plazas had tolls suspended from September 5, 2017 to September 21, 2017 due to Hurricane Irma.



Dean Mainline Toll Facility
SR 408 - East-West Expressway
 Typical Daily Traffic Volumes - April 2018

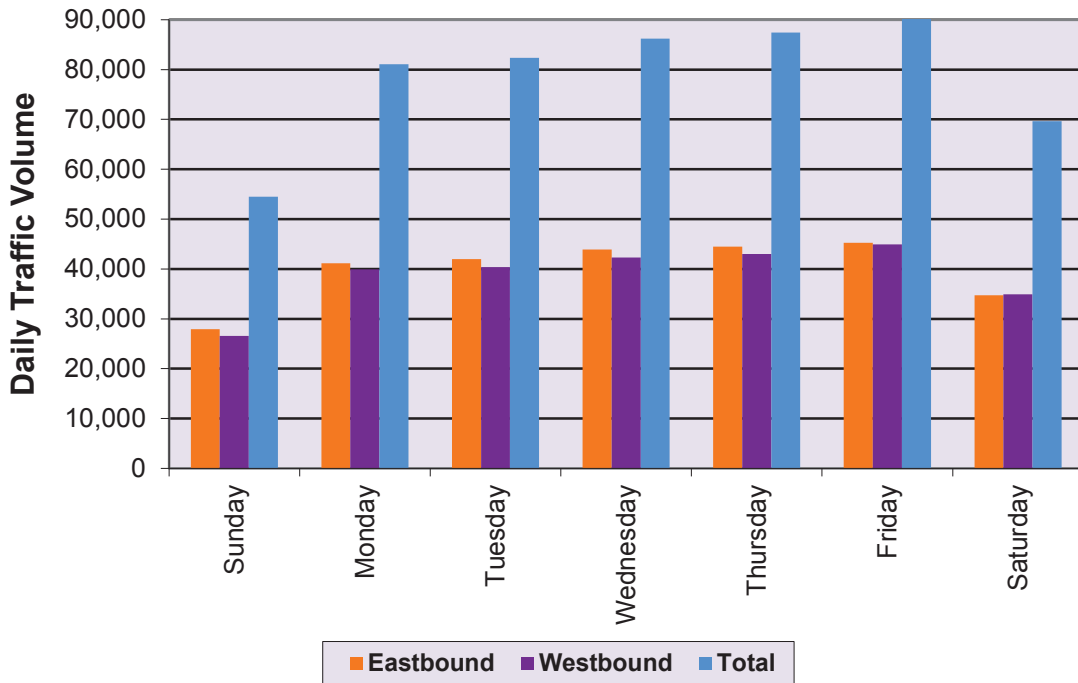

Day	Expressway Traffic Volumes		
	Eastbound	Westbound	Total
Sunday	27,908	26,562	54,470
Monday	41,159	39,893	81,051
Tuesday	41,999	40,346	82,345
Wednesday	43,902	42,277	86,179
Thursday	44,452	42,985	87,437
Friday	45,238	44,916	90,154
Saturday	34,691	34,940	69,631

Dean Mainline Toll Facility
SR 408 - East-West Expressway
Average Five Day Hourly Traffic - April 2018

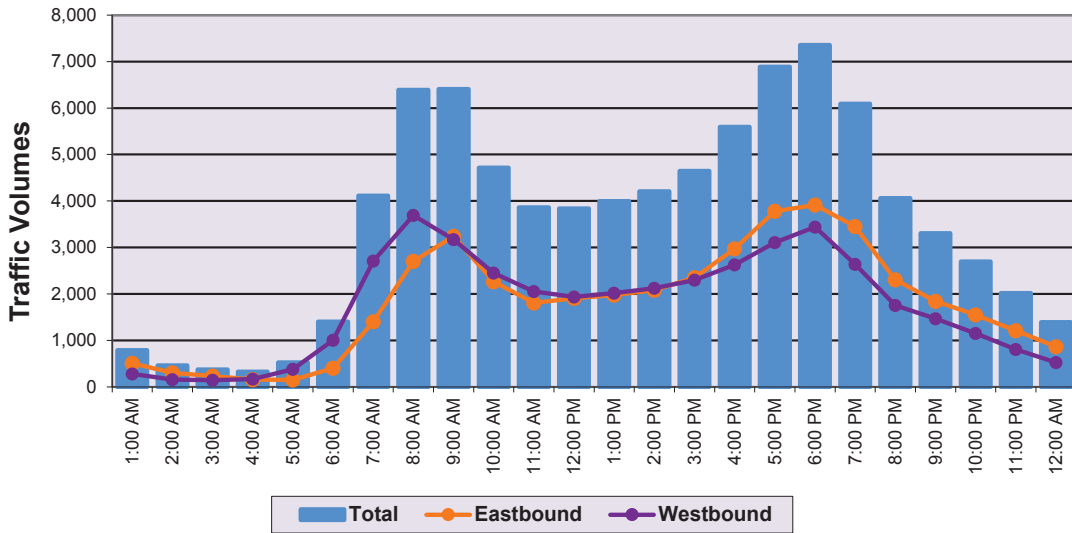

Hour Ending	Average Weekday Volumes		
	Eastbound	Westbound	Total
1:00 AM	510	279	788
2:00 AM	304	155	459
3:00 AM	233	142	375
4:00 AM	155	170	324
5:00 AM	147	376	523
6:00 AM	401	1,004	1,406
7:00 AM	1,404	2,709	4,113
8:00 AM	2,701	3,691	6,392
9:00 AM	3,239	3,170	6,409
10:00 AM	2,262	2,451	4,713
11:00 AM	1,805	2,054	3,858
12:00 PM	1,906	1,933	3,838

Hour Ending	Average Weekday Volumes		
	Eastbound	Westbound	Total
1:00 PM	1,979	2,016	3,995
2:00 PM	2,084	2,122	4,205
3:00 PM	2,349	2,298	4,647
4:00 PM	2,969	2,625	5,594
5:00 PM	3,777	3,107	6,884
6:00 PM	3,914	3,439	7,353
7:00 PM	3,451	2,639	6,091
8:00 PM	2,302	1,755	4,057
9:00 PM	1,841	1,465	3,306
10:00 PM	1,546	1,152	2,699
11:00 PM	1,209	806	2,015
12:00 AM	862	527	1,390

Total Eastbound	43,350
Total Westbound	42,083
Total Weekday	85,433



Dean Mainline Toll Facility
SR 408 - East-West Expressway
Average Seven Day Hourly Traffic - April 2018

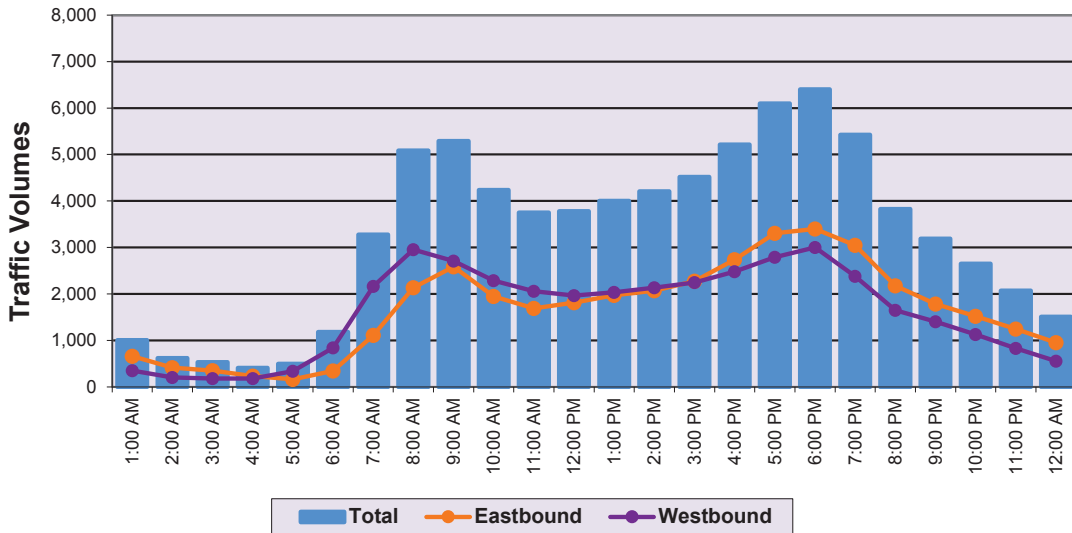

Hour Ending	Average Weekday Volumes			Hour Ending	Average Weekday Volumes		
	Eastbound	Westbound	Total		Eastbound	Westbound	Total
1:00 AM	657	348	1,004	1:00 PM	1,969	2,033	4,002
2:00 AM	416	204	619	2:00 PM	2,072	2,133	4,206
3:00 AM	347	182	530	3:00 PM	2,273	2,245	4,518
4:00 AM	232	178	410	4:00 PM	2,736	2,479	5,216
5:00 AM	161	335	497	5:00 PM	3,308	2,789	6,096
6:00 AM	343	838	1,181	6:00 PM	3,398	3,001	6,399
7:00 AM	1,110	2,166	3,276	7:00 PM	3,046	2,379	5,424
8:00 AM	2,136	2,951	5,087	8:00 PM	2,174	1,651	3,825
9:00 AM	2,582	2,705	5,288	9:00 PM	1,786	1,401	3,187
10:00 AM	1,946	2,289	4,235	10:00 PM	1,519	1,130	2,649
11:00 AM	1,691	2,058	3,749	11:00 PM	1,242	830	2,072
12:00 PM	1,814	1,963	3,777	12:00 AM	950	556	1,507

Total Eastbound	39,907
Total Westbound	38,845
Total Weekday	78,752



SR 408 (EAST-WEST EXPRESSWAY)
Dean Mainline Toll Facility

Dean Mainline Toll Facility

Toll Facility Peak Hour Characteristic Summary Typical Average Weekday (Monday through Friday) - April 2018

Average Weekday Traffic Summary (unadjusted)

Average Weekday Total Traffic	85,433
Eastbound Directional Traffic	43,350
Westbound Directional Traffic	42,083

Morning Peak Hour Summary (7:00 a.m. to 8:00 a.m.)

Eastbound Directional Traffic	3,239
Westbound Directional Traffic	3,170
Total AM Peak Hour Traffic	6,409

AM Peak Hour Factor ("K") = Total Peak Hour Traffic / Average Weekday Total Traffic

AM Peak Hour Factor ("K_{am}") 7.50%

AM Peak Hour Directional Factor ("D") = Peak Directional Traffic / Total Peak Hour Traffic

AM Peak Hour Directional Factor ("D_{am}") 50.54%

Evening Peak Hour Summary (5:00 p.m. to 6:00 p.m.)

Eastbound Directional Traffic	3,914
Westbound Directional Traffic	3,439
Total PM Peak Hour Traffic	7,353

PM Peak Hour Factor ("K") = Total Peak Hour Traffic / Average Weekday Total Traffic

PM Peak Hour Factor ("K_{pm}") 8.61%

PM Peak Hour Directional Factor ("D") = Peak Directional Traffic / Total Peak Hour Traffic

PM Peak Hour Directional Factor ("D_{pm}") 53.23%

Dean Mainline Toll Facility

Toll Transaction Summary

Typical Average Weekday (Monday through Friday) - April 2018

Average Weekday Summary

Direction of Travel	E-PASS (AVI)		ACM (Coin)		Manual (Cash)		Total	
	Volume	% Usage	Volume	% Usage	Volume	% Usage	Traffic	% Usage
Eastbound	40,435	94%	568	1%	1,873	4%	42,876	100%
Westbound	39,073	94%	468	1%	2,093	5%	41,634	100%

Morning Peak Hour Summary (7:00 a.m. to 8:00 a.m.)

Direction of Travel	E-PASS (AVI)		ACM (Coin)		Manual (Cash)		Total	
	Volume	% Usage	Volume	% Usage	Volume	% Usage	Traffic	% Usage
Eastbound	3,080	96%	33	1%	106	3%	3,219	100%
Westbound	3,004	96%	21	1%	109	3%	3,134	100%

Evening Peak Hour Summary (5:00 p.m. to 6:00 p.m.)

Direction Of Travel	E-PASS (AVI)		ACM (Coin)		Manual (Cash)		Total	
	Volume	% Usage	Volume	% Usage	Volume	% Usage	Traffic	% Usage
Eastbound	3,707	96%	39	1%	126	3%	3,872	100%
Westbound	3,221	94%	31	1%	163	5%	3,415	100%

Dean Mainline Toll Facility
SR 408 - East-West Expressway
Historical & Existing Total Revenue Transactions Statistics

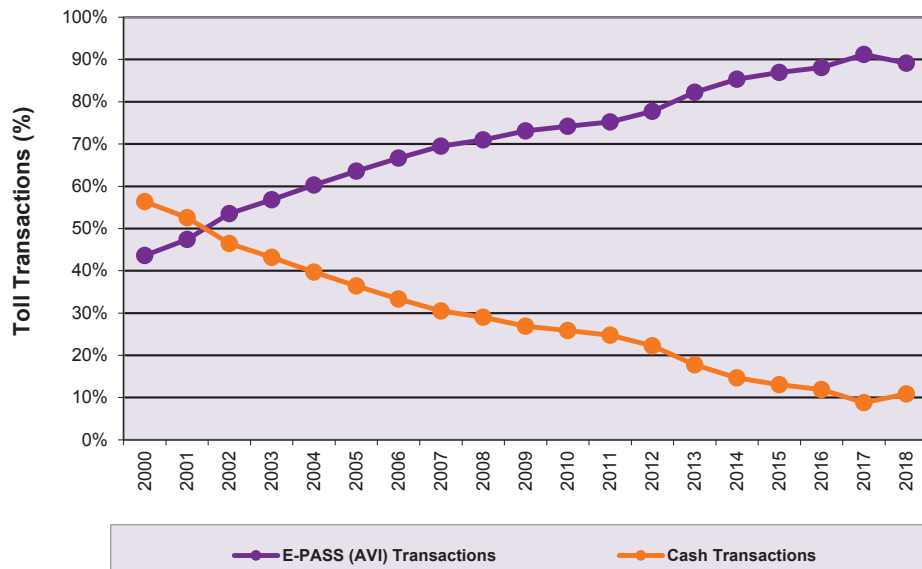

Year	Yearly Revenue Transaction		% Violations ⁽²⁾ (Percent of Total Transactions)
	% E-PASS (AVI) Transactions	% Cash Transactions	
2000	43.7%	56.3%	1.9%
2001	47.4%	52.6%	1.7%
2002	53.5%	46.5%	1.5%
2003	56.8%	43.2%	1.3%
2004	60.3%	39.7%	1.6%
2005	63.6%	36.4%	2.8%
2006	66.7%	33.3%	2.4%
2007	69.5%	30.5%	2.4%
2008	71.0%	29.0%	2.4%
2009	73.1%	26.9%	3.3%
2010	74.2%	25.8%	3.7%
2011	75.2%	24.8%	3.7%
2012	77.8%	22.2%	4.0%
2013	82.2%	17.8%	4.7%
2014	85.3%	14.7%	5.5%
2015	87.0%	13.0%	6.4%
2016	88.1%	11.9%	7.3%
2017	91.2%	8.8%	9.6%
2018	89.1%	10.9%	13.2%

1. In FY 18, all plazas had tolls suspended from September 5, 2017 to September 21, 2017 due to Hurricane Irma.

2. Calculated as percentage of Total Transactions, which is equal to Revenue Transactions plus Violations.



Beachline Mainline Toll Facility (Beachline Expressway)



2018 Traffic Data and Statistics Manual
CENTRAL FLORIDA EXPRESSWAY AUTHORITY

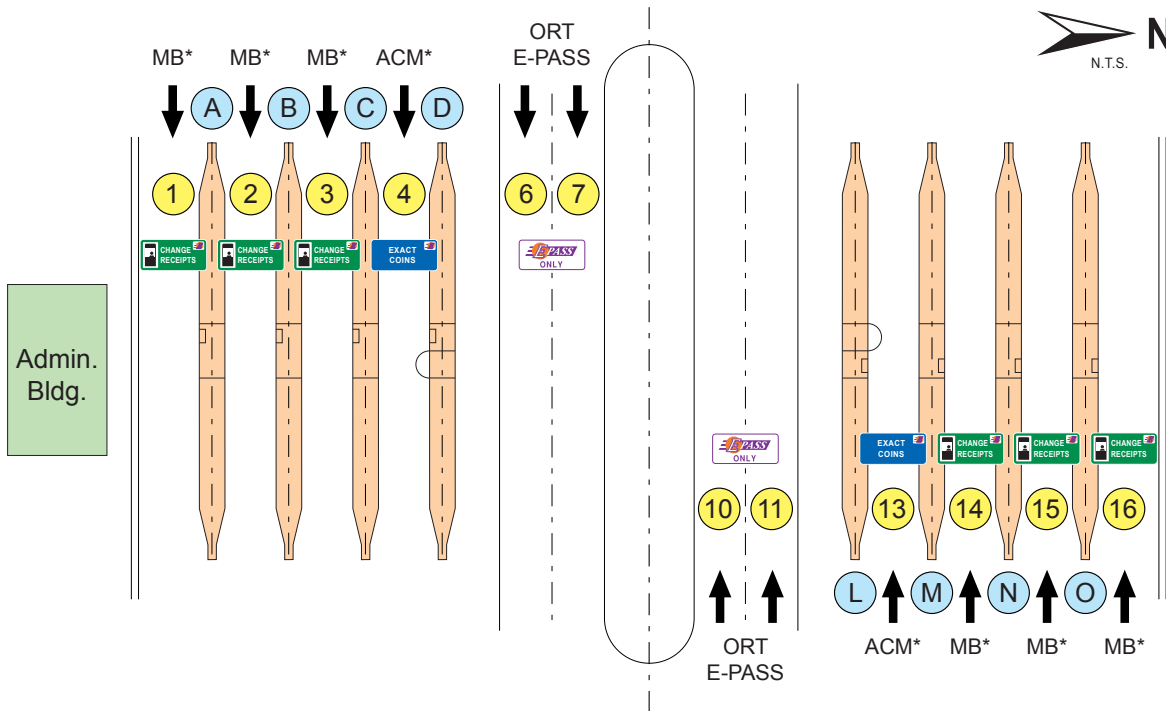

HISTORIC TRAFFIC - A.A.W.T.

1992	18,630 (<i>Post Toll</i>)	2001	34,590	2010	46,300
1993	21,090	2002	36,760	2011	46,880
1994	21,800	2003	39,940	2012	48,430 (<i>Toll Increase July 2012</i>)
1995	22,130	2004	45,930	2013	49,230
1996	23,920	2005	46,000	2014	53,510
1997	25,520	2006	46,300	2015	56,120
1998	29,420	2007	47,700	2016	60,710
1999	29,970	2008	42,500	2017	65,540
2000	33,590	2009	43,300 (<i>Toll Increase April 2009</i>)	2018	72,670 (<i>Toll Increase July 2018</i>)

TOLL RATE STRUCTURE**

	<u>E-PASS</u>	<u>CASH</u>
2 Axles	\$.91	\$ 1.25
3 Axles	\$ 1.79	\$ 2.00
4 Axles	\$ 2.09	\$ 2.50
5 Axles or more	\$ 2.66	\$ 3.00

(Toll Rates Effective July 1, 2019)

LANES OF EQUIPMENT

- 6 Manned Booths (MB) with E-PASS
- 2 Booths with Automatic Coin Machines (ACM) and E-PASS
- 4 Open Road Tolling (ORT) E-PASS
- * Changeable Message Sign
- ** \$0.25 of toll paid to FDOT for removed FDOT plaza

LEGEND

- ① Lane Number
- Ⓐ Island Designation



Approx. Scale: 1" = 200'
January 2018

Beachline Mainline Toll Facility

SR 528 - Beachline Expressway

Fiscal Year 2018 Monthly Mainline & Ramp Toll Transactions and Revenue Summary

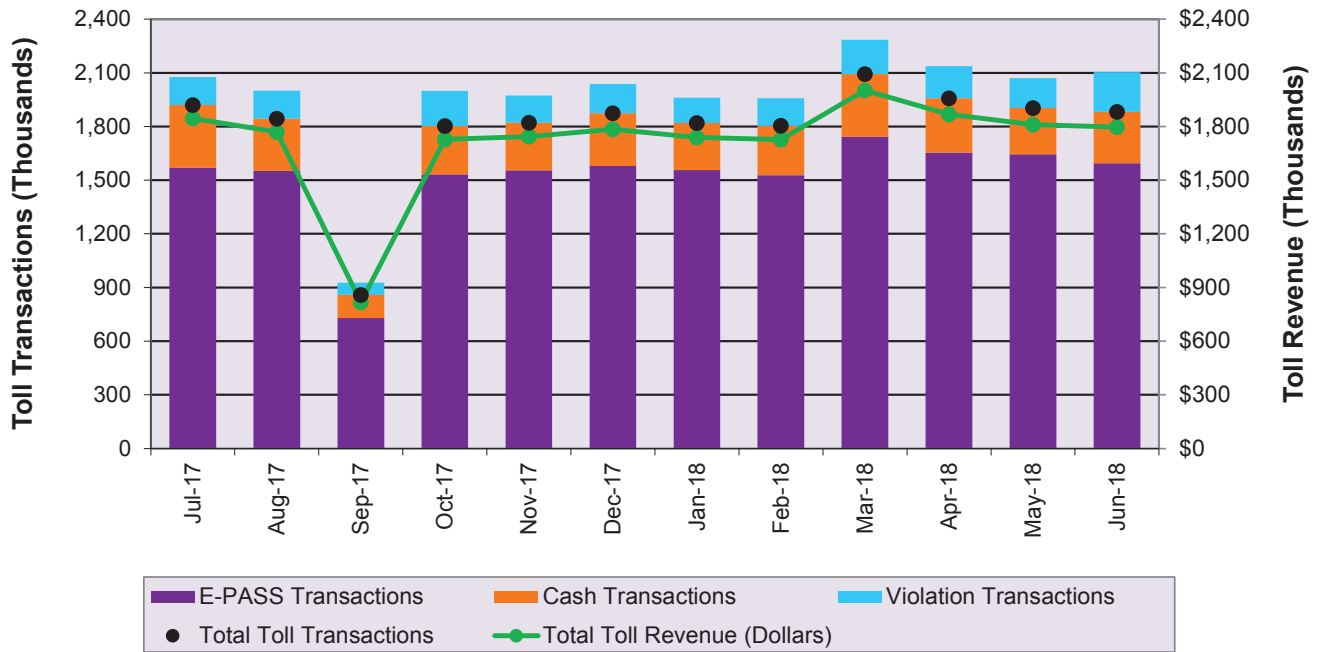

Month	FY 18 MONTHLY MAINLINE & RAMP TOLL TRANSACTIONS					Total Toll Revenue
	E-PASS	Cash	Total Revenue	Violations	Total	
July-17	1,567,970	351,648	1,919,618	156,588	2,076,206	\$1,844,725
August-17	1,552,507	292,059	1,844,566	155,709	2,000,275	\$1,769,487
September-17	729,730	128,626	858,356	69,302	927,658	\$817,669
October-17	1,532,411	270,645	1,803,056	195,437	1,998,493	\$1,728,597
November-17	1,554,683	266,501	1,821,184	152,718	1,973,902	\$1,743,257
December-17	1,579,328	295,545	1,874,873	161,638	2,036,511	\$1,785,394
January-18	1,556,306	262,972	1,819,278	141,998	1,961,276	\$1,739,272
February-18	1,527,838	276,964	1,804,802	152,836	1,957,638	\$1,726,995
March-18	1,742,294	350,587	2,092,881	191,752	2,284,633	\$2,001,756
April-18	1,654,208	304,063	1,958,271	179,501	2,137,772	\$1,868,016
May-18	1,644,961	257,732	1,902,693	168,590	2,071,283	\$1,810,521
June-18	1,593,878	287,437	1,881,315	223,009	2,104,324	\$1,796,314
Yearly Totals	18,236,114	3,344,779	21,580,893	1,949,078	23,529,971	\$20,632,003

Note: Data includes ramp toll plazas that report to the Beachline Mainline Toll Plaza.

1. Cash transactions are calculated as the difference between total revenue traffic and E-PASS traffic.

2. In FY 18, all plazas had tolls suspended from September 5, 2017 to September 21, 2017 due to Hurricane Irma.



SR 528 (BEACHLINE EXPRESSWAY) Beachline Mainline Toll Facility

Beachline Mainline Toll Facility

SR 528 - Beachline Expressway

Typical Daily Expressway Traffic Volumes - April 2018

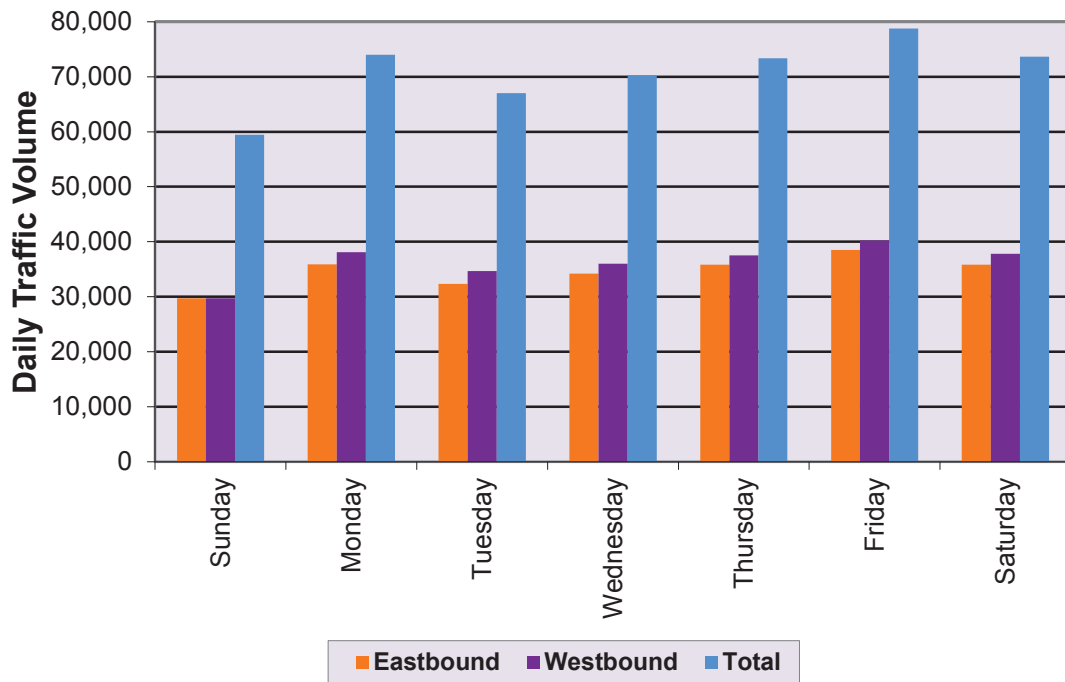

Day	Expressway Traffic Volumes		
	Eastbound	Westbound	Total
Sunday	29,733	29,717	59,450
Monday	35,911	38,078	73,989
Tuesday	32,336	34,675	67,011
Wednesday	34,205	36,020	70,225
Thursday	35,841	37,523	73,364
Friday	38,515	40,259	78,774
Saturday	35,823	37,834	73,657

Beachline Mainline Toll Facility
SR 528 - Beachline Expressway
Typical Average Five Day Hourly Traffic - April 2018

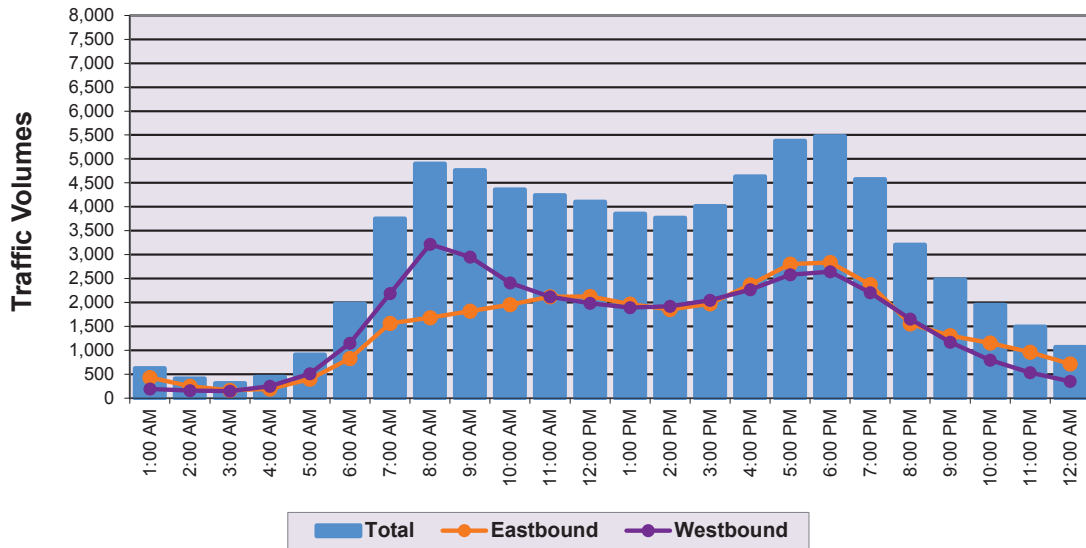

Hour Ending	Average Weekday Volumes		
	Eastbound	Westbound	Total
1:00 AM	432	189	621
2:00 AM	247	158	405
3:00 AM	161	148	310
4:00 AM	191	249	440
5:00 AM	395	511	906
6:00 AM	826	1,145	1,970
7:00 AM	1,564	2,189	3,753
8:00 AM	1,683	3,216	4,899
9:00 AM	1,818	2,947	4,766
10:00 AM	1,953	2,408	4,361
11:00 AM	2,121	2,121	4,242
12:00 PM	2,125	1,982	4,107

Hour Ending	Average Weekday Volumes		
	Eastbound	Westbound	Total
1:00 PM	1,965	1,892	3,856
2:00 PM	1,849	1,918	3,768
3:00 PM	1,969	2,045	4,013
4:00 PM	2,367	2,269	4,635
5:00 PM	2,801	2,577	5,378
6:00 PM	2,835	2,640	5,475
7:00 PM	2,374	2,203	4,577
8:00 PM	1,552	1,654	3,206
9:00 PM	1,308	1,172	2,480
10:00 PM	1,155	796	1,950
11:00 PM	957	534	1,491
12:00 AM	716	350	1,066

Total Eastbound	35,361
Total Westbound	37,311
Total Weekday	72,672



Beachline Mainline Toll Facility
SR 528 - Beachline Expressway
Typical Average Seven Day Hourly Traffic - April 2018

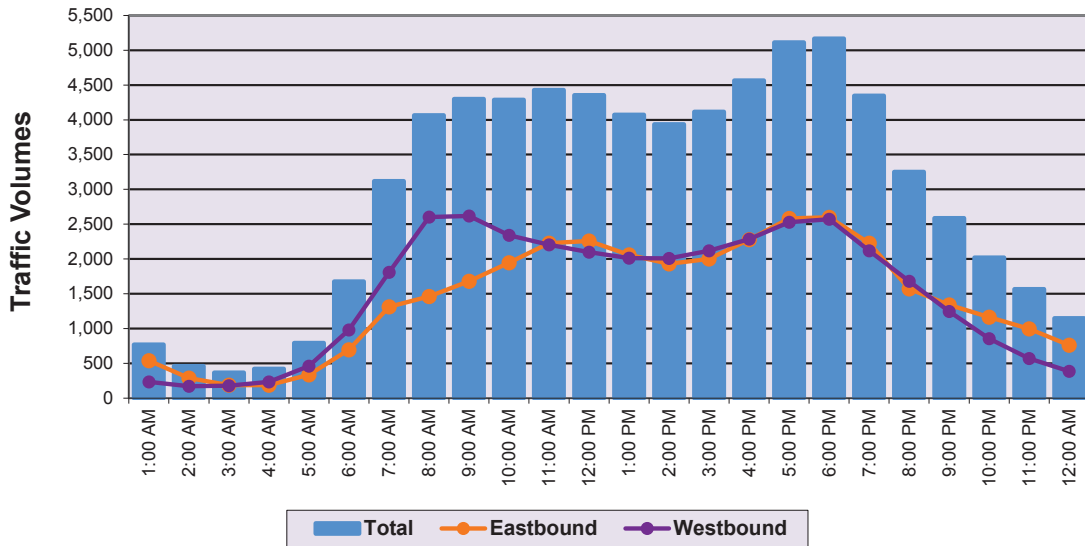

Hour Ending	Average Weekday Volumes			Hour Ending	Average Weekday Volumes		
	Eastbound	Westbound	Total		Eastbound	Westbound	Total
1:00 AM	537	232	768	1:00 PM	2,061	2,012	4,073
2:00 AM	289	169	458	2:00 PM	1,930	2,007	3,937
3:00 AM	188	177	364	3:00 PM	2,000	2,117	4,117
4:00 AM	188	234	422	4:00 PM	2,278	2,287	4,565
5:00 AM	335	459	794	5:00 PM	2,583	2,528	5,111
6:00 AM	695	980	1,675	6:00 PM	2,597	2,571	5,168
7:00 AM	1,310	1,809	3,119	7:00 PM	2,226	2,119	4,346
8:00 AM	1,462	2,601	4,063	8:00 PM	1,570	1,680	3,250
9:00 AM	1,681	2,618	4,299	9:00 PM	1,341	1,247	2,588
10:00 AM	1,947	2,341	4,288	10:00 PM	1,165	856	2,021
11:00 AM	2,227	2,202	4,429	11:00 PM	996	570	1,566
12:00 PM	2,257	2,098	4,355	12:00 AM	762	386	1,148

Total Eastbound	34,623
Total Westbound	36,301
Total Weekday	70,924



SR 528 (BEACHLINE EXPRESSWAY)
Beachline Mainline Toll Facility

Beachline Mainline Toll Facility

Toll Facility Peak Hour Characteristic Summary Typical Average Weekday (Monday through Friday) - April 2018

Average Weekday Traffic Summary (unadjusted)

Average Weekday Total Traffic	72,672
Eastbound Directional Traffic	35,361
Westbound Directional Traffic	37,311

Morning Peak Hour Summary (7:00 a.m. to 8:00 a.m.)

Eastbound Directional Traffic	1,683
Westbound Directional Traffic	3,216
Total AM Peak Hour Traffic	4,899

AM Peak Hour Factor ("K") = Total Peak Hour Traffic / Average Weekday Total Traffic

AM Peak Hour Factor ("K_{am}") 6.74%

AM Peak Hour Directional Factor ("D") = Peak Directional Traffic / Total Peak Hour Traffic

AM Peak Hour Directional Factor ("D_{am}") 65.64%

Evening Peak Hour Summary (5:00 p.m. to 6:00 p.m.)

Eastbound Directional Traffic	2,835
Westbound Directional Traffic	2,640
Total PM Peak Hour Traffic	5,475

PM Peak Hour Factor ("K") = Total Peak Hour Traffic / Average Weekday Total Traffic

PM Peak Hour Factor ("K_{pm}") 7.53%

PM Peak Hour Directional Factor ("D") = Peak Directional Traffic / Total Peak Hour Traffic

PM Peak Hour Directional Factor ("D_{pm}") 51.78%

Beachline Mainline Toll Facility

Toll Transaction Summary

Typical Average Weekday (Monday through Friday) - April 2018

Average Weekday Summary

Direction of Travel	E-PASS (AVI)		ACM (Coin)		Manual (Cash)		Total	
	Volume	% Usage	Volume	% Usage	Volume	% Usage	Traffic	% Usage
Eastbound	30,037	85%	989	3%	4,191	12%	35,217	100%
Westbound	31,657	85%	1,308	4%	4,187	11%	37,153	100%

Morning Peak Hour Summary (7:00 a.m. to 8:00 a.m.)

Direction of Travel	E-PASS (AVI)		ACM (Coin)		Manual (Cash)		Total	
	Volume	% Usage	Volume	% Usage	Volume	% Usage	Traffic	% Usage
Eastbound	1,586	88%	43	2%	184	10%	1,812	100%
Westbound	2,622	89%	82	3%	228	8%	2,931	100%

Evening Peak Hour Summary (5:00 p.m. to 6:00 p.m.)

Direction of Travel	E-PASS (AVI)		ACM (Coin)		Manual (Cash)		Total	
	Volume	% Usage	Volume	% Usage	Volume	% Usage	Traffic	% Usage
Eastbound	2,539	90%	50	2%	232	8%	2,820	100%
Westbound	2,175	83%	101	4%	359	14%	2,634	100%



Beachline Mainline Toll Facility
SR 528 - Beachline Expressway
Historical & Existing Total Revenue Transactions Statistics

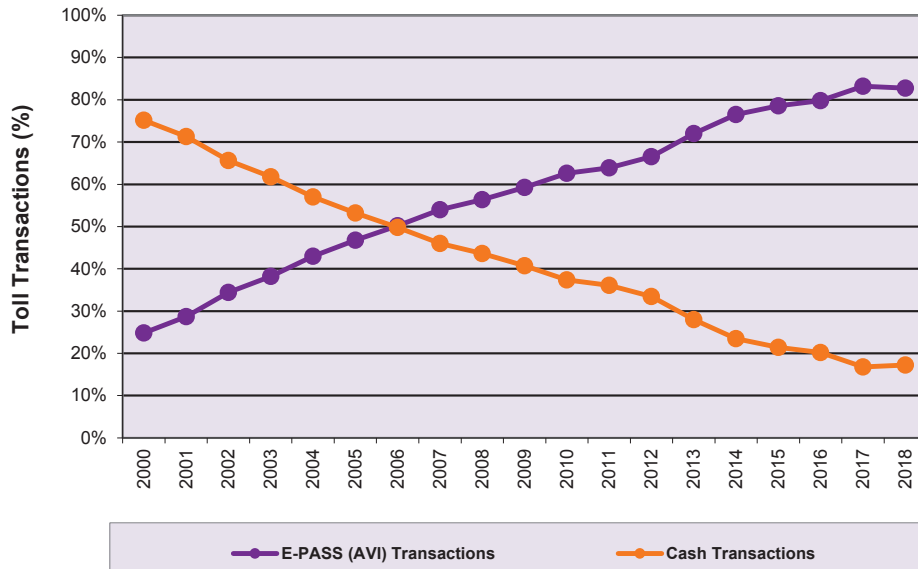

Year	Yearly Revenue Transaction		% Violations ⁽²⁾ (Percent of Total Transactions)
	% E-PASS (AVI) Transactions	% Cash Transactions	
2000	24.8%	75.2%	2.5%
2001	28.7%	71.3%	2.0%
2002	34.4%	65.6%	1.7%
2003	38.2%	61.8%	1.8%
2004	43.0%	57.0%	2.3%
2005	46.8%	53.2%	2.7%
2006	50.2%	49.8%	2.6%
2007	54.0%	46.0%	2.1%
2008	56.3%	43.7%	2.1%
2009	59.3%	40.7%	3.6%
2010	62.6%	37.4%	3.7%
2011	63.9%	36.1%	4.1%
2012	66.5%	33.5%	3.2%
2013	72.0%	28.0%	3.5%
2014	76.5%	23.5%	4.2%
2015	78.6%	21.4%	5.0%
2016	79.8%	20.2%	5.6%
2017	83.2%	16.8%	7.4%
2018	82.7%	17.3%	11.5%

1. In FY 18, all plazas had tolls suspended from September 5, 2017 to September 21, 2017 due to Hurricane Irma.
2. Calculated as percentage of Total Transactions, which is equal to Revenue Transactions plus Violations.



Dallas Mainline Toll Facility (Beachline Expressway)



2018 Traffic Data and Statistics Manual
CENTRAL FLORIDA EXPRESSWAY AUTHORITY

OSCEOLA

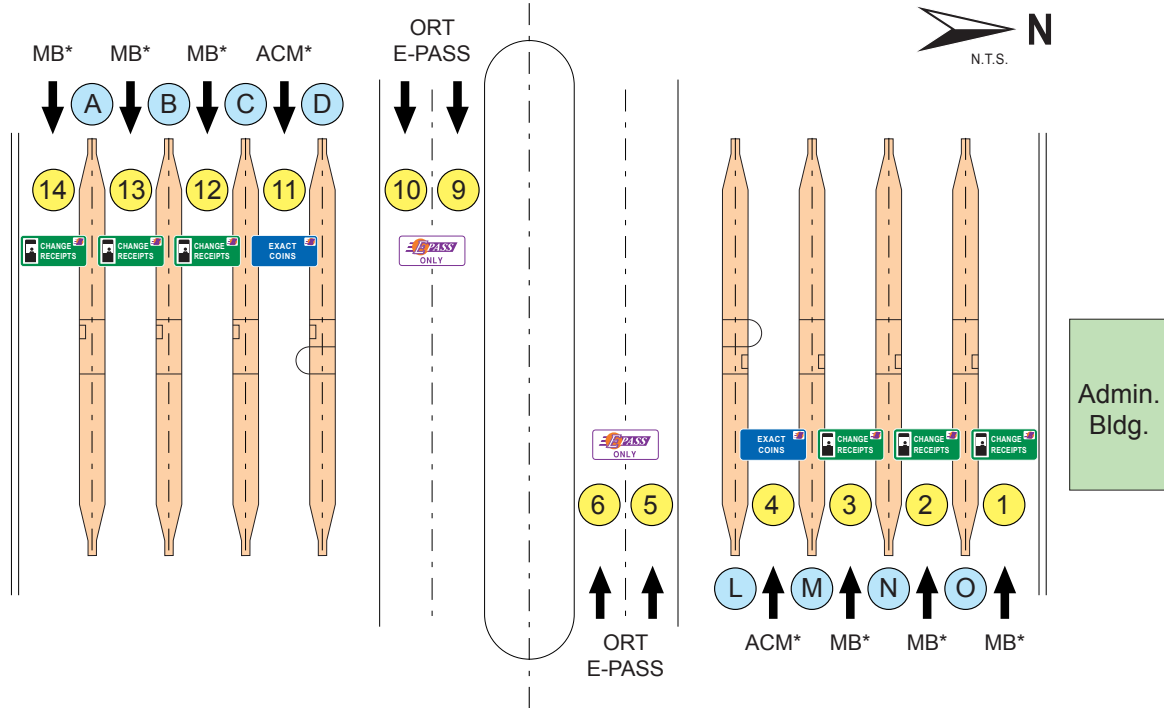

HISTORIC TRAFFIC - A.A.W.T.

2012	38,360	2015	45,530	2018	57,230 (Toll Increase July 2018)
2013	39,190	2016	46,880		
2014	40,890	2017	51,122		

TOLL RATE STRUCTURE

	E-PASS	CASH
2 Axles	\$.52	\$.75
3 Axles	\$.79	\$ 1.00
4 Axles	\$ 1.04	\$ 1.25
5 Axles or more	\$ 1.04	\$ 1.25

(Toll Rates Effective July 1, 2019)

LANES OF EQUIPMENT

- 6 Manned Booths (MB) with E-PASS
- 2 Booths with Automatic Coin Machines (ACM) and E-PASS
- 4 Open Road Tolling (ORT) E-PASS
- * Changeable Message Sign

LEGEND

- ① Lane Number
- Ⓐ Island Designation



Approx. Scale: 1" = 200'
January 2018

Dallas Mainline Toll Facility

SR 528 - Beachline Expressway

Fiscal Year 2018 Monthly Mainline & Ramp Toll Transactions and Revenue Summary

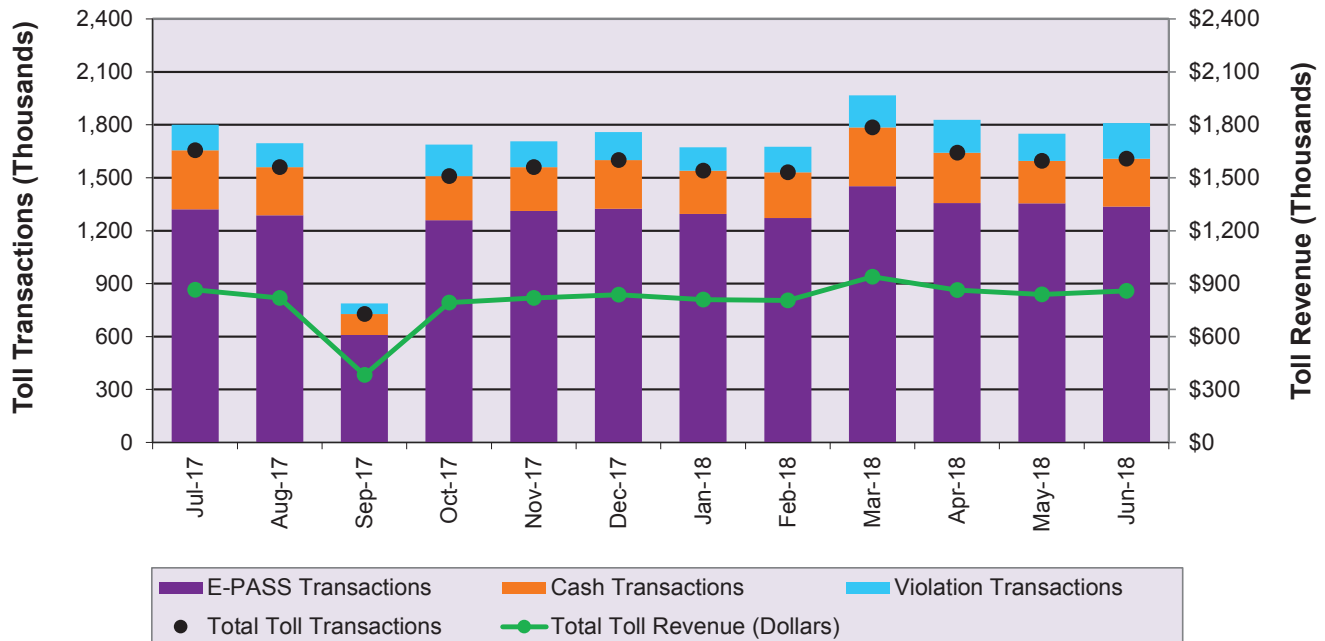

Month	FY 18 MONTHLY MAINLINE & RAMP TOLL TRANSACTIONS					Total Toll Revenue
	E-PASS	Cash	Total Revenue	Violations	Total	
July-17	1,321,614	333,405	1,655,019	145,354	1,800,373	\$865,429
August-17	1,287,320	272,504	1,559,824	136,324	1,696,148	\$819,072
September-17	608,367	118,770	727,137	60,041	787,178	\$382,258
October-17	1,259,486	250,142	1,509,628	178,662	1,688,290	\$792,157
November-17	1,311,577	249,078	1,560,655	145,442	1,706,097	\$818,692
December-17	1,323,566	276,303	1,599,869	159,718	1,759,587	\$837,619
January-18	1,294,689	245,213	1,539,902	133,327	1,673,229	\$809,688
February-18	1,271,657	259,264	1,530,921	144,225	1,675,146	\$803,997
March-18	1,451,785	332,558	1,784,343	183,175	1,967,518	\$938,556
April-18	1,356,707	285,291	1,641,998	185,643	1,827,641	\$863,208
May-18	1,354,738	240,243	1,594,981	154,435	1,749,416	\$838,298
June-18	1,336,025	272,148	1,608,173	202,160	1,810,333	\$859,134
Yearly Totals	15,177,531	3,134,919	18,312,450	1,828,506	20,140,956	\$9,628,108

Note: Data includes ramp toll plazas that report to the Dallas Mainline Toll Plaza.

1. Cash transactions are calculated as the difference between total revenue traffic and E-PASS traffic.

2. In FY 18, all plazas had tolls suspended from September 5, 2017 to September 21, 2017 due to Hurricane Irma.



Dallas Mainline Toll Facility
SR 528 - Beachline Expressway
Typical Daily Expressway Traffic Volumes - April 2018

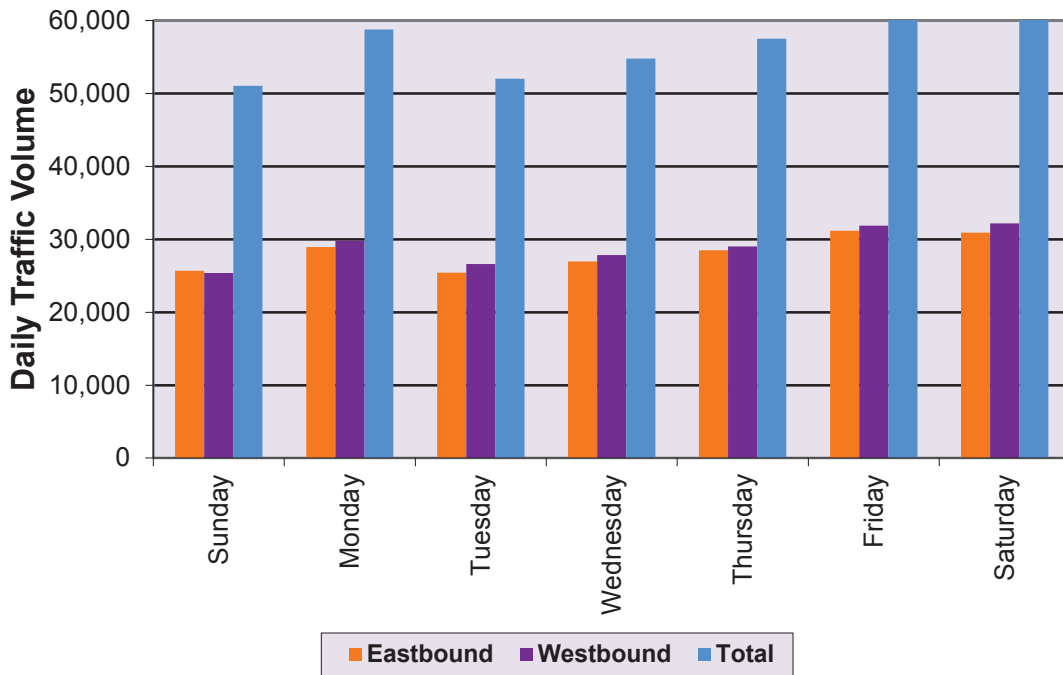

Day	Expressway Traffic Volumes		
	Eastbound	Westbound	Total
Sunday	25,674	25,388	51,062
Monday	28,956	29,836	58,792
Tuesday	25,418	26,623	52,041
Wednesday	26,960	27,827	54,786
Thursday	28,486	29,025	57,511
Friday	31,168	31,869	63,037
Saturday	30,898	32,191	63,088

Dallas Mainline Toll Facility
SR 528 - Beachline Expressway
 Typical Average Five Day Hourly Traffic - April 2018

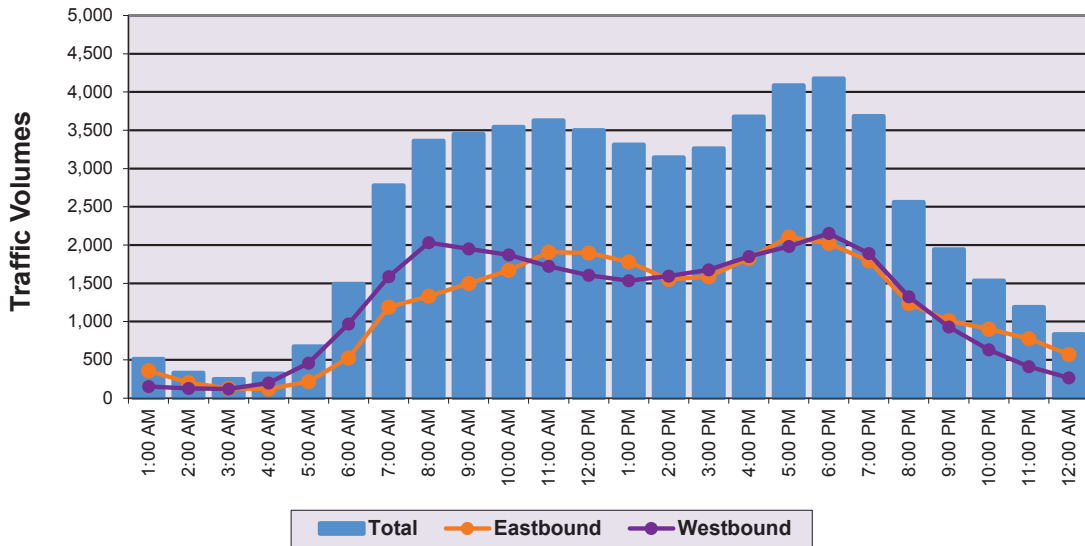

Hour Ending	Average Weekday Volumes		
	Eastbound	Westbound	Total
1:00 AM	358	152	509
2:00 AM	201	127	328
3:00 AM	127	120	248
4:00 AM	120	198	318
5:00 AM	217	458	675
6:00 AM	524	968	1,492
7:00 AM	1,189	1,589	2,778
8:00 AM	1,330	2,032	3,362
9:00 AM	1,498	1,952	3,450
10:00 AM	1,670	1,872	3,543
11:00 AM	1,908	1,722	3,629
12:00 PM	1,896	1,604	3,500

Hour Ending	Average Weekday Volumes		
	Eastbound	Westbound	Total
1:00 PM	1,778	1,533	3,310
2:00 PM	1,551	1,594	3,145
3:00 PM	1,586	1,676	3,262
4:00 PM	1,827	1,851	3,678
5:00 PM	2,105	1,983	4,088
6:00 PM	2,020	2,153	4,174
7:00 PM	1,793	1,891	3,684
8:00 PM	1,235	1,325	2,560
9:00 PM	1,013	929	1,942
10:00 PM	903	631	1,534
11:00 PM	777	413	1,190
12:00 AM	571	264	835

Total Eastbound	28,197
Total Westbound	29,036
Total Weekday	57,233



SR 528 (BEACHLINE EXPRESSWAY)
Dallas Mainline Toll Facility

Dallas Mainline Toll Facility
SR 528 - Beachline Expressway
 Typical Average Seven Day Hourly Traffic - April 2018

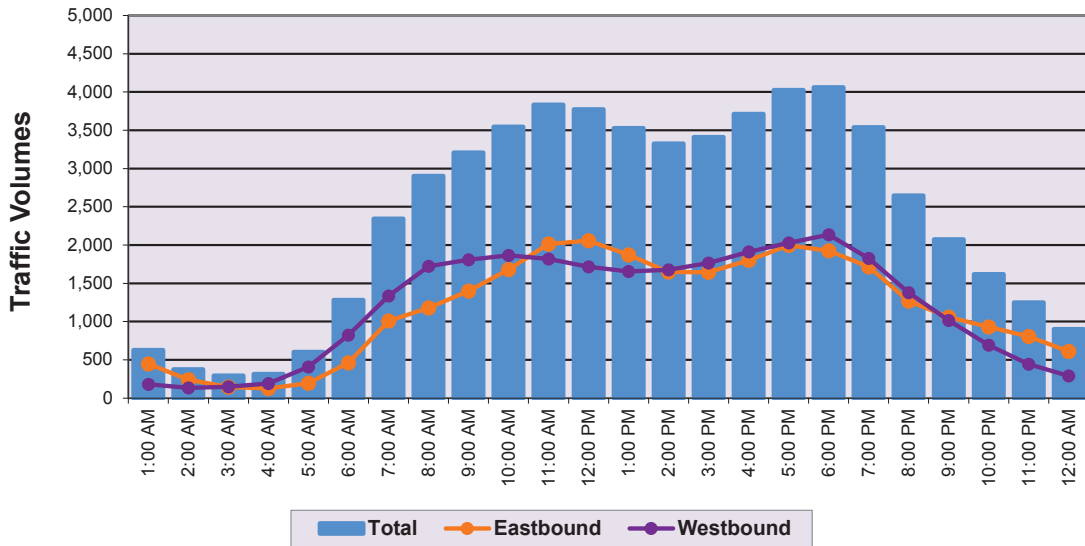

Hour Ending	Average Weekday Volumes		
	Eastbound	Westbound	Total
1:00 AM	447	179	626
2:00 AM	239	135	374
3:00 AM	146	149	295
4:00 AM	127	189	316
5:00 AM	196	409	604
6:00 AM	460	822	1,282
7:00 AM	1,009	1,336	2,345
8:00 AM	1,178	1,723	2,901
9:00 AM	1,400	1,808	3,208
10:00 AM	1,681	1,866	3,547
11:00 AM	2,013	1,820	3,833
12:00 PM	2,055	1,717	3,772

Hour Ending	Average Weekday Volumes		
	Eastbound	Westbound	Total
1:00 PM	1,871	1,655	3,527
2:00 PM	1,649	1,675	3,324
3:00 PM	1,644	1,765	3,409
4:00 PM	1,801	1,912	3,712
5:00 PM	1,996	2,029	4,025
6:00 PM	1,926	2,134	4,061
7:00 PM	1,714	1,826	3,540
8:00 PM	1,267	1,379	2,646
9:00 PM	1,058	1,015	2,073
10:00 PM	929	690	1,619
11:00 PM	805	444	1,249
12:00 AM	612	290	902

Total Eastbound	28,223
Total Westbound	28,965
Total Weekday	57,188



SR 528 (BEACHLINE EXPRESSWAY)
Dallas Mainline Toll Facility

Dallas Mainline Toll Facility

Toll Facility Peak Hour Characteristic Summary Typical Average Weekday (Monday through Friday) - April 2018

Average Weekday Traffic Summary (unadjusted)

Average Weekday Total Traffic	57,233
Eastbound Directional Traffic	28,197
Westbound Directional Traffic	29,036

Morning Peak Hour Summary (7:00 a.m. to 8:00 a.m.)

Eastbound Directional Traffic	1,498
Westbound Directional Traffic	1,952
Total AM Peak Hour Traffic	3,450

AM Peak Hour Factor ("K") = Total Peak Hour Traffic / Average Weekday Total Traffic

AM Peak Hour Factor ("K_{am}") **6.03%**

AM Peak Hour Directional Factor ("D") = Peak Directional Traffic / Total Peak Hour Traffic

AM Peak Hour Directional Factor ("D_{am}") **56.57%**

Evening Peak Hour Summary (5:00 p.m. to 6:00 p.m.)

Eastbound Directional Traffic	2,020
Westbound Directional Traffic	2,153
Total PM Peak Hour Traffic	4,174

PM Peak Hour Factor ("K") = Total Peak Hour Traffic / Average Weekday Total Traffic

PM Peak Hour Factor ("K_{pm}") **7.29%**

PM Peak Hour Directional Factor ("D") = Peak Directional Traffic / Total Peak Hour Traffic

PM Peak Hour Directional Factor ("D_{pm}") **51.59%**

Dallas Mainline Toll Facility

Toll Transaction Summary

Typical Average Weekday (Monday through Friday) - April 2018

Average Weekday Summary

Direction of Travel	E-PASS (AVI)		ACM (Coin)		Manual (Cash)		Total	
	Volume	% Usage	Volume	% Usage	Volume	% Usage	Traffic	% Usage
Eastbound	23,402	83%	924	3%	3,799	14%	28,124	100%
Westbound	24,003	83%	1,118	4%	3,837	13%	28,958	100%

Morning Peak Hour Summary (7:00 a.m. to 8:00 a.m.)

Direction of Travel	E-PASS (AVI)		ACM (Coin)		Manual (Cash)		Total	
	Volume	% Usage	Volume	% Usage	Volume	% Usage	Traffic	% Usage
Eastbound	1,305	87%	30	2%	159	11%	1,493	100%
Westbound	1,677	86%	63	3%	205	11%	1,945	100%

Evening Peak Hour Summary (5:00 p.m. to 6:00 p.m.)

Direction of Travel	E-PASS (AVI)		ACM (Coin)		Manual (Cash)		Total	
	Volume	% Usage	Volume	% Usage	Volume	% Usage	Traffic	% Usage
Eastbound	1,760	87%	44	2%	209	10%	2,012	100%
Westbound	1,729	80%	102	5%	319	15%	2,150	100%

Dallas Mainline Toll Facility
SR 528 - Beachline Expressway
Historical & Existing Total Revenue Transactions Statistics

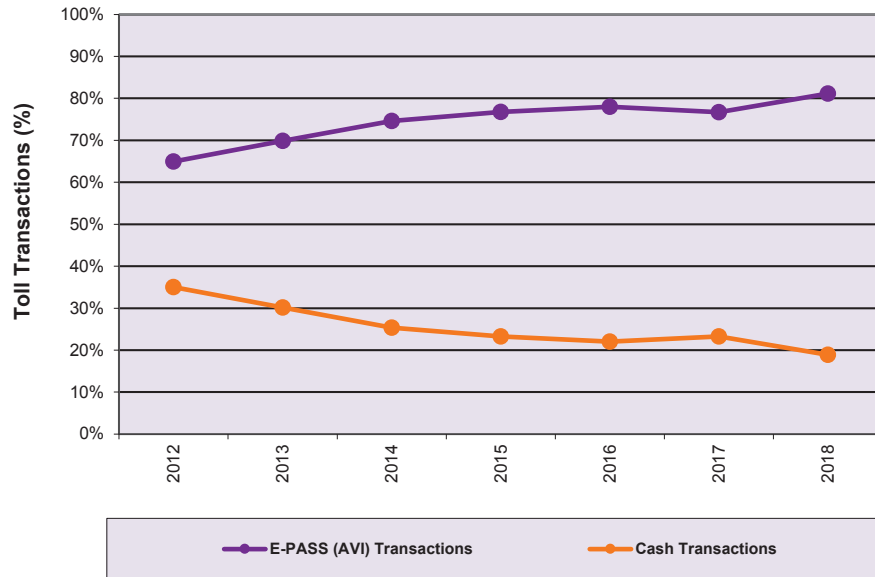

Year	Yearly Revenue Transaction		% Violations ⁽²⁾ (Percent of Total Transactions)
	% E-PASS (AVI) Transactions	% Cash Transactions	
2000	Not Open to Traffic		
2001	Not Open to Traffic		
2002	Not Open to Traffic		
2003	Not Open to Traffic		
2004	Not Open to Traffic		
2005	Not Open to Traffic		
2006	Not Open to Traffic		
2007	Not Open to Traffic		
2008	Not Open to Traffic		
2009	Not Open to Traffic		
2010	Not Open to Traffic		
2011	Not Open to Traffic		
2012	64.9%	35.1%	3.3%
2013	69.8%	30.2%	3.6%
2014	74.6%	25.4%	4.2%
2015	76.7%	23.3%	4.9%
2016	78.0%	22.0%	5.7%
2017	76.7%	23.3%	11.3%
2018	81.1%	18.9%	12.4%

1. In FY 18, all plazas had tolls suspended from September 5, 2017 to September 21, 2017 due to Hurricane Irma.
2. Calculated as percentage of Total Transactions, which is equal to Revenue Transactions plus Violations.



John Young Mainline Toll Facility (Central Florida GreeneWay)



2018 Traffic Data and Statistics Manual
CENTRAL FLORIDA EXPRESSWAY AUTHORITY

OSCEOLA

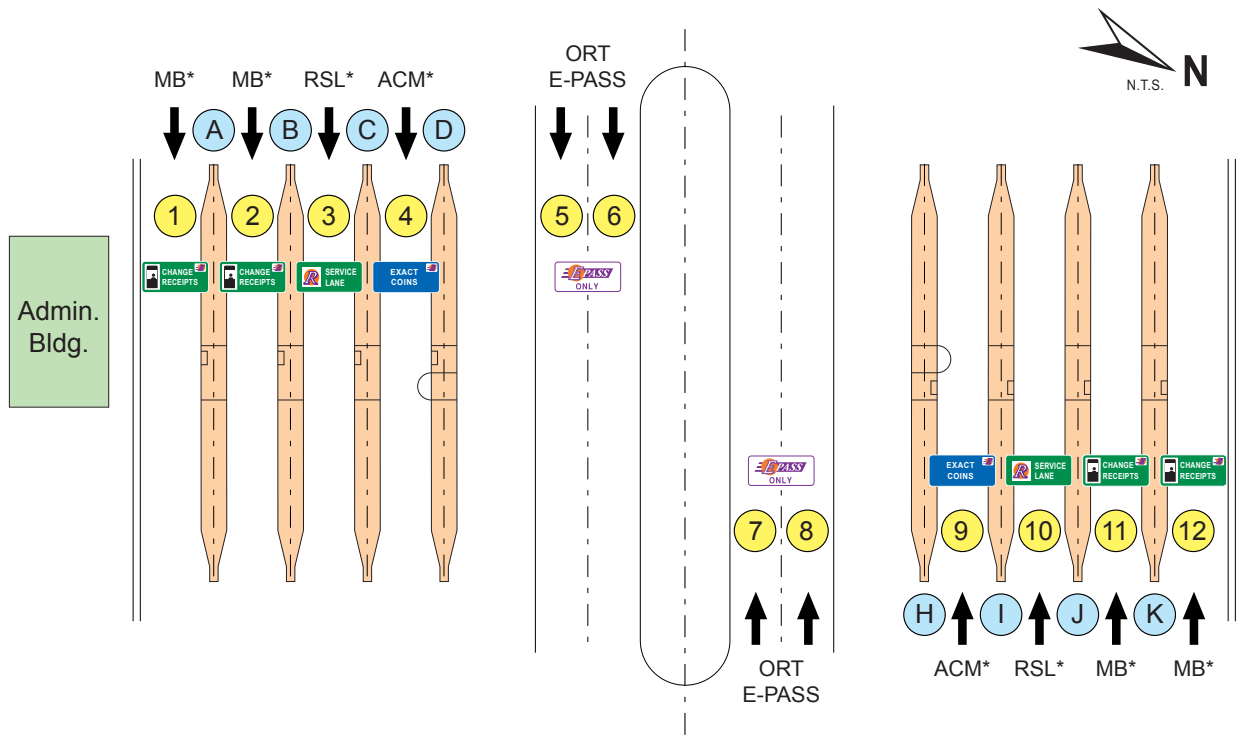

HISTORIC TRAFFIC - A.A.W.T.

1993	7,370	2002	32,020	2011	41,400
1994	11,370	2003	33,240	2012	41,300 <i>(Toll Increase July 2012)</i>
1995	13,070	2004	40,000	2013	44,780
1996	17,520	2005	40,500	2014	44,780
1997	20,550	2006	42,700	2015	51,500
1998	22,660	2007	45,800	2016	62,150
1999	25,630	2008	43,500	2017	76,880
2000	28,660	2009	38,200 <i>(Toll Increase April 2009)</i>	2018	83,600 <i>(Toll Increase July 2018)</i>
2001	29,160	2010	39,630		

TOLL RATE STRUCTURE

	E-PASS	CASH
2 Axles	\$ 1.43	\$ 1.75
3 Axles	\$ 1.99	\$ 2.25
4 Axles	\$ 2.57	\$ 3.00
5 Axles or more	\$ 3.13	\$ 3.50

(Toll Rates Effective July 1, 2019)

LANES OF EQUIPMENT

- 4 Manned Booths (MB) with E-PASS
- 2 Booths with Automatic Coin Machines (ACM) and E-PASS
- 2 Reload Service Lanes (RSL)
- 4 Open Road Tolling (ORT) E-PASS
- * Changeable Message Sign

LEGEND

- ① Lane Number
- Ⓐ Island Designation



Approx. Scale: 1" = 200'
January 2018

John Young Mainline Toll Facility

SR 417 - Central Florida GreenWay

Fiscal Year 2018 Monthly Mainline & Ramp Toll Transactions and Revenue Summary

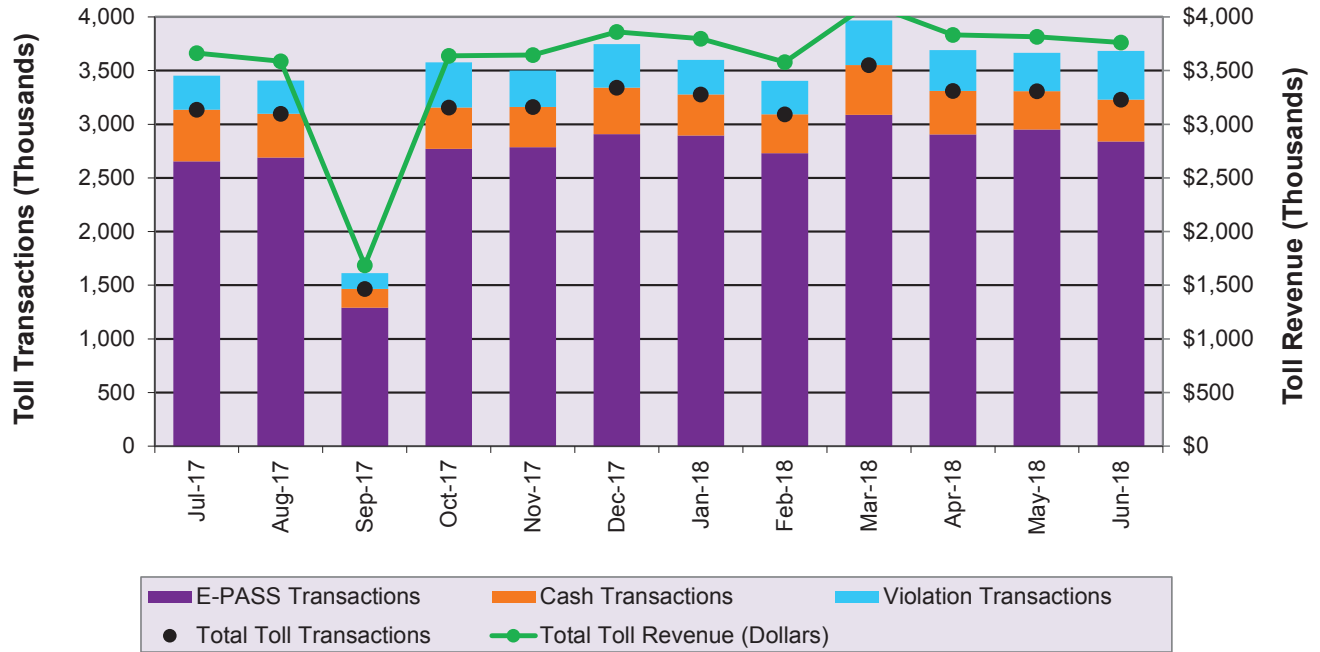

Month	FY 18 MONTHLY MAINLINE & RAMP TOLL TRANSACTIONS					Total Toll Revenue
	E-PASS	Cash	Total Revenue	Violations	Total	
July-17	2,653,464	481,711	3,135,175	318,424	3,453,599	\$3,662,326
August-17	2,689,340	407,330	3,096,670	310,993	3,407,663	\$3,587,898
September-17	1,289,413	177,081	1,466,494	144,721	1,611,215	\$1,686,869
October-17	2,770,839	385,388	3,156,227	421,188	3,577,415	\$3,638,548
November-17	2,785,437	376,736	3,162,173	338,395	3,500,568	\$3,645,687
December-17	2,908,323	432,527	3,340,850	405,226	3,746,076	\$3,859,466
January-18	2,895,312	383,224	3,278,536	320,531	3,599,067	\$3,796,689
February-18	2,729,714	362,497	3,092,211	312,320	3,404,531	\$3,578,915
March-18	3,088,244	464,202	3,552,446	414,696	3,967,142	\$4,125,255
April-18	2,904,672	405,961	3,310,633	379,442	3,690,075	\$3,832,525
May-18	2,950,822	357,471	3,308,293	357,726	3,666,019	\$3,815,970
June-18	2,838,791	391,972	3,230,763	452,390	3,683,153	\$3,762,177
Yearly Totals	32,504,371	4,626,100	37,130,471	4,176,052	41,306,523	\$42,992,325

Note: Data includes ramp toll plazas that report to the John Young Mainline Toll Plaza.

1. Cash transactions are calculated as the difference between total revenue traffic and E-PASS traffic.

2. In FY 18, all plazas had tolls suspended from September 5, 2017 to September 21, 2017 due to Hurricane Irma.



John Young Mainline Toll Facility
SR 417 - Central Florida GreeneWay
Typical Daily Expressway Traffic Volumes - April 2018

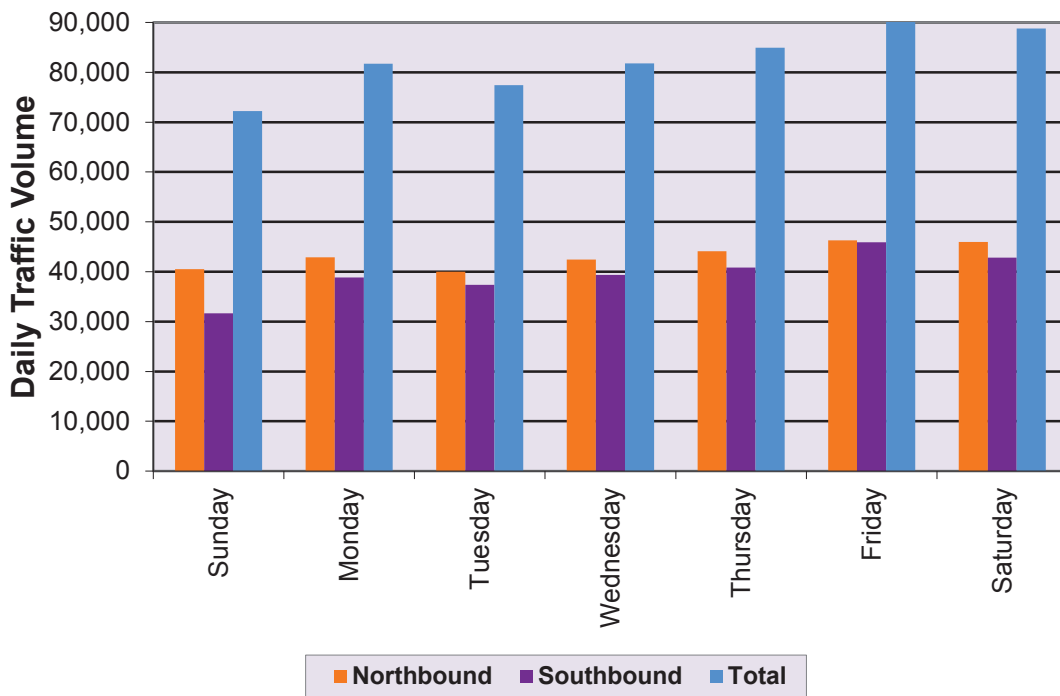

Day	Expressway Traffic Volumes		
	Northbound	Southbound	Total
Sunday	40,530	31,689	72,218
Monday	42,885	38,819	81,704
Tuesday	40,035	37,373	77,407
Wednesday	42,422	39,355	81,777
Thursday	44,094	40,835	84,928
Friday	46,283	45,898	92,181
Saturday	45,988	42,821	88,809



John Young Mainline Toll Facility SR 417 - Central Florida GreeneWay Typical Average Five Day Hourly Traffic - April 2018

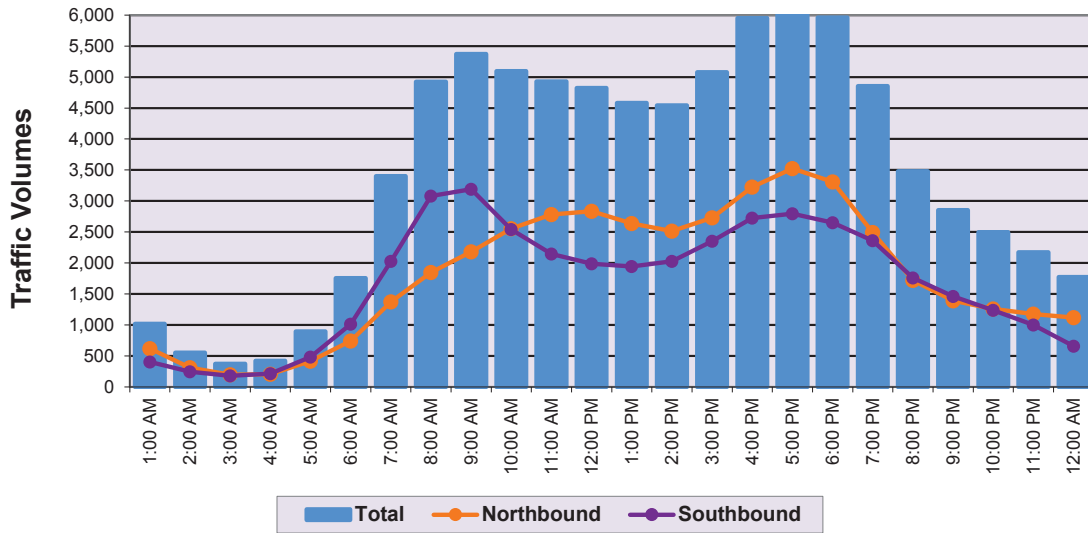

Hour Ending	Average Weekday Volumes			Hour Ending	Average Weekday Volumes		
	Northbound	Southbound	Total		Northbound	Southbound	Total
1:00 AM	617	401	1,018	1:00 PM	2,637	1,942	4,580
2:00 AM	308	243	551	2:00 PM	2,515	2,026	4,542
3:00 AM	194	178	372	3:00 PM	2,730	2,349	5,079
4:00 AM	203	215	418	4:00 PM	3,226	2,722	5,949
5:00 AM	415	481	896	5:00 PM	3,524	2,795	6,319
6:00 AM	740	1,013	1,753	6:00 PM	3,309	2,652	5,960
7:00 AM	1,374	2,027	3,401	7:00 PM	2,493	2,360	4,852
8:00 AM	1,846	3,078	4,924	8:00 PM	1,721	1,758	3,479
9:00 AM	2,179	3,190	5,370	9:00 PM	1,390	1,462	2,852
10:00 AM	2,555	2,540	5,095	10:00 PM	1,260	1,236	2,496
11:00 AM	2,783	2,145	4,928	11:00 PM	1,173	999	2,172
12:00 PM	2,835	1,989	4,824	12:00 AM	1,116	655	1,772

Total Northbound	43,144
Total Southbound	40,456
Total Weekday	83,599



John Young Mainline Toll Facility
SR 417 - Central Florida GreeneWay
Typical Average Seven Day Hourly Traffic - April 2018

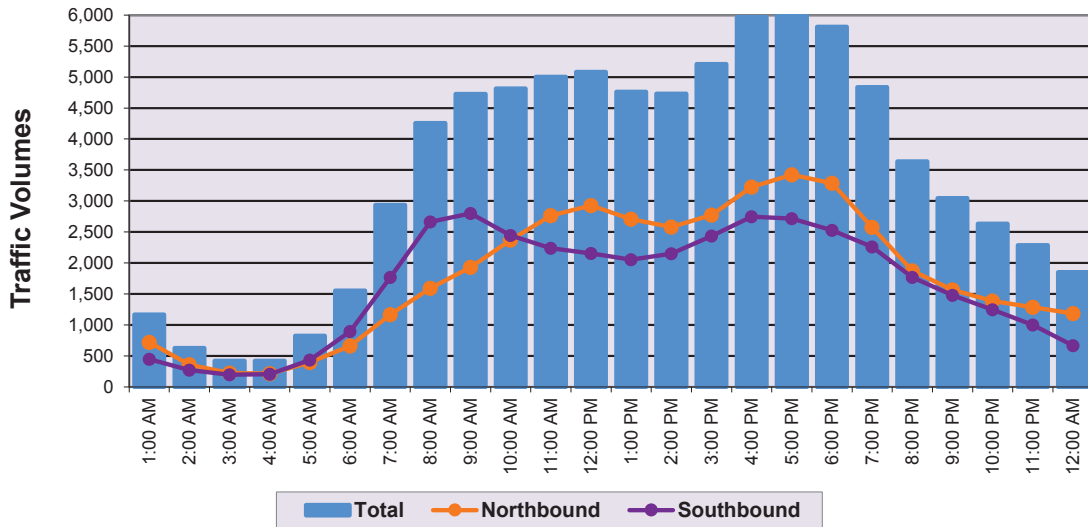

Hour Ending	Average Weekday Volumes			Hour Ending	Average Weekday Volumes		
	Northbound	Southbound	Total		Northbound	Southbound	Total
1:00 AM	718	447	1,165	1:00 PM	2,708	2,053	4,760
2:00 AM	357	271	628	2:00 PM	2,582	2,148	4,730
3:00 AM	222	198	419	3:00 PM	2,774	2,434	5,208
4:00 AM	214	205	418	4:00 PM	3,224	2,746	5,970
5:00 AM	392	432	824	5:00 PM	3,423	2,715	6,138
6:00 AM	659	892	1,551	6:00 PM	3,285	2,528	5,812
7:00 AM	1,168	1,768	2,936	7:00 PM	2,574	2,260	4,834
8:00 AM	1,592	2,662	4,254	8:00 PM	1,873	1,765	3,638
9:00 AM	1,930	2,798	4,728	9:00 PM	1,567	1,477	3,044
10:00 AM	2,371	2,441	4,812	10:00 PM	1,386	1,245	2,631
11:00 AM	2,763	2,239	5,002	11:00 PM	1,285	999	2,283
12:00 PM	2,929	2,154	5,083	12:00 AM	1,183	667	1,851

Total Northbound	43,176
Total Southbound	39,541
Total Weekday	82,718



John Young Mainline Toll Facility

Toll Facility Peak Hour Characteristic Summary Typical Average Weekday (Monday through Friday) - April 2018

Average Weekday Traffic Summary (unadjusted)

Average Weekday Total Traffic	83,599
Northbound Directional Traffic	43,144
Southbound Directional Traffic	40,456

Morning Peak Hour Summary (7:00 a.m. to 8:00 a.m.)

Northbound Directional Traffic	2,179
Southbound Directional Traffic	3,190
Total AM Peak Hour Traffic	5,370

AM Peak Hour Factor ("K") = Total Peak Hour Traffic / Average Weekday Total Traffic

AM Peak Hour Factor ("K_{am}") 6.42%

AM Peak Hour Directional Factor ("D") = Peak Directional Traffic / Total Peak Hour Traffic

AM Peak Hour Directional Factor ("D_{am}") 59.41%

Evening Peak Hour Summary (5:00 p.m. to 6:00 p.m.)

Northbound Directional Traffic	3,309
Southbound Directional Traffic	2,652
Total PM Peak Hour Traffic	5,960

PM Peak Hour Factor ("K") = Total Peak Hour Traffic / Average Weekday Total Traffic

PM Peak Hour Factor ("K_{pm}") 7.13%

PM Peak Hour Directional Factor ("D") = Peak Directional Traffic / Total Peak Hour Traffic

PM Peak Hour Directional Factor ("D_{pm}") 55.51%

John Young Mainline Toll Facility

Toll Transaction Summary

Typical Average Weekday (Monday through Friday) - April 2018

Average Weekday Summary

Direction of Travel	E-PASS (AVI)		ACM (Coin)		Manual (Cash)		Total	
	Volume	% Usage	Volume	% Usage	Volume	% Usage	Traffic	% Usage
Northbound	37,331	87%	797	2%	4,865	11%	42,993	100%
Southbound	35,381	88%	636	2%	4,300	11%	40,317	100%

Morning Peak Hour Summary (7:00 a.m. to 8:00 a.m.)

Direction of Travel	E-PASS (AVI)		ACM (Coin)		Manual (Cash)		Total	
	Volume	% Usage	Volume	% Usage	Volume	% Usage	Traffic	% Usage
Northbound	1,905	88%	27	1%	243	11%	2,174	100%
Southbound	2,969	93%	26	1%	185	6%	3,180	100%

Evening Peak Hour Summary (5:00 p.m. to 6:00 p.m.)

Direction of Travel	E-PASS (AVI)		ACM (Coin)		Manual (Cash)		Total	
	Volume	% Usage	Volume	% Usage	Volume	% Usage	Traffic	% Usage
Northbound	2,951	89%	32	1%	316	10%	3,299	100%
Southbound	2,233	84%	50	2%	360	14%	2,643	100%



John Young Mainline Toll Facility
SR 417 - Central Florida GreenWay
Historical & Existing Total Revenue Transactions Statistics

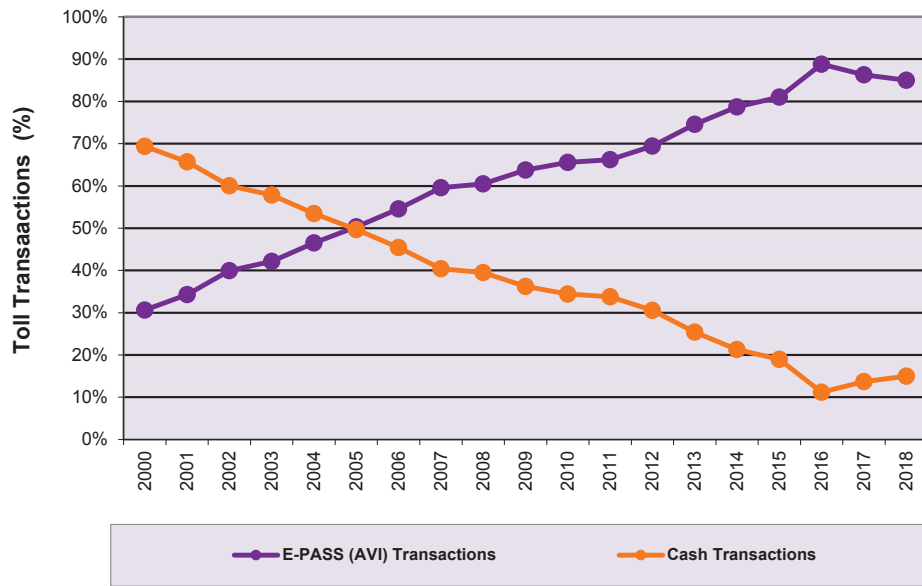

Year	Yearly Revenue Transaction		% Violations ⁽²⁾ (Percent of Total Transactions)
	% E-PASS (AVI) Transactions	% Cash Transactions	
2000	30.6%	69.4%	1.8%
2001	34.3%	65.7%	1.7%
2002	40.0%	60.0%	1.6%
2003	42.1%	57.9%	1.5%
2004	46.5%	53.5%	1.7%
2005	50.3%	49.7%	2.0%
2006	54.6%	45.4%	2.5%
2007	59.6%	40.4%	2.6%
2008	60.5%	39.5%	2.5%
2009	63.8%	36.2%	2.9%
2010	65.6%	34.4%	2.8%
2011	66.2%	33.8%	2.5%
2012	69.4%	30.6%	3.1%
2013	74.6%	25.4%	3.3%
2014	78.7%	21.3%	4.3%
2015	81.0%	19.0%	5.2%
2016	88.8%	11.2%	6.5%
2017	86.3%	13.7%	8.8%
2018	85.0%	15.0%	13.7%

1. In FY 18, all plazas had tolls suspended from September 5, 2017 to September 21, 2017 due to Hurricane Irma.
2. Calculated as percentage of Total Transactions, which is equal to Revenue Transactions plus Violations.



Boggy Creek Mainline Toll Facility (Central Florida GreeneWay)



2018 Traffic Data and Statistics Manual
CENTRAL FLORIDA EXPRESSWAY AUTHORITY

OSCEOLA

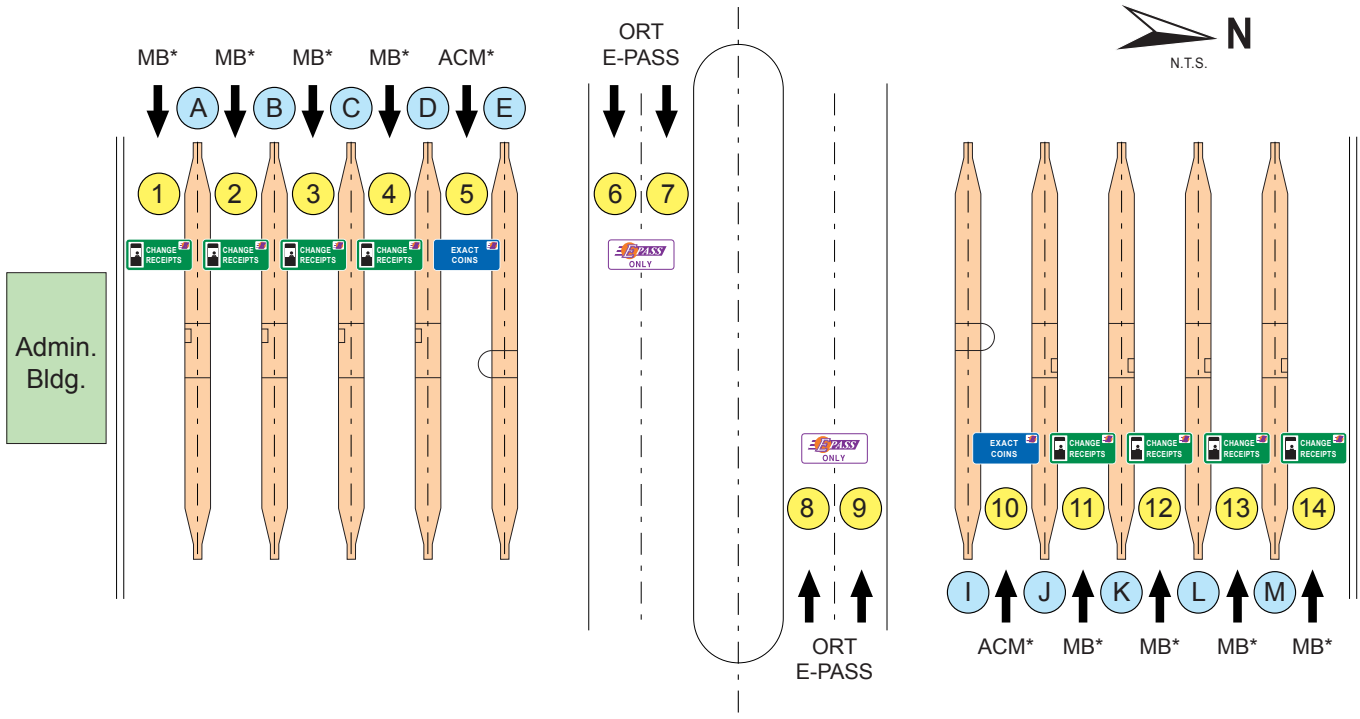

HISTORIC TRAFFIC - A.A.W.T.

1993	6,200	2002	28,120	2011	38,300
1994	10,750	2003	30,190	2012	38,350 <i>(Toll Increase July 2012)</i>
1995	11,970	2004	36,920	2013	40,300
1996	15,780	2005	37,900	2014	44,880
1997	17,760	2006	42,400	2015	54,580
1998	20,400	2007	44,800	2016	66,700
1999	22,440	2008	44,400	2017	78,830
2000	24,380	2009	35,900 <i>(Toll Increase April 2009)</i>	2018	87,570 <i>(Toll Increase July 2018)</i>
2001	25,180	2010	36,520		

TOLL RATE STRUCTURE

	<u>E-PASS</u>	<u>CASH</u>
2 Axles	\$ 1.43	\$ 1.75
3 Axles	\$ 1.99	\$ 2.25
4 Axles	\$ 2.57	\$ 3.00
5 Axles or more	\$ 3.13	\$ 3.50

(Toll Rates Effective July 1, 2019)

LANES OF EQUIPMENT

- 8 Manned Booths (MB) with E-PASS
- 2 Booths with Automatic Coin Machines (ACM) and E-PASS
- 4 Open Road Tolling (ORT) E-PASS
- * Changeable Message Sign

LEGEND

- ① Lane Number
- Ⓐ Island Designation



**SR 417 (CENTRAL FLORIDA GREENEWAY)
Boggy Creek Mainline Toll Facility**

SECTION III



Approx. Scale: 1" = 200'
January 2018

Boggy Creek Mainline Toll Facility

SR 417 - Central Florida GreenWay

Fiscal Year 2018 Monthly Mainline & Ramp Toll Transactions and Revenue Summary

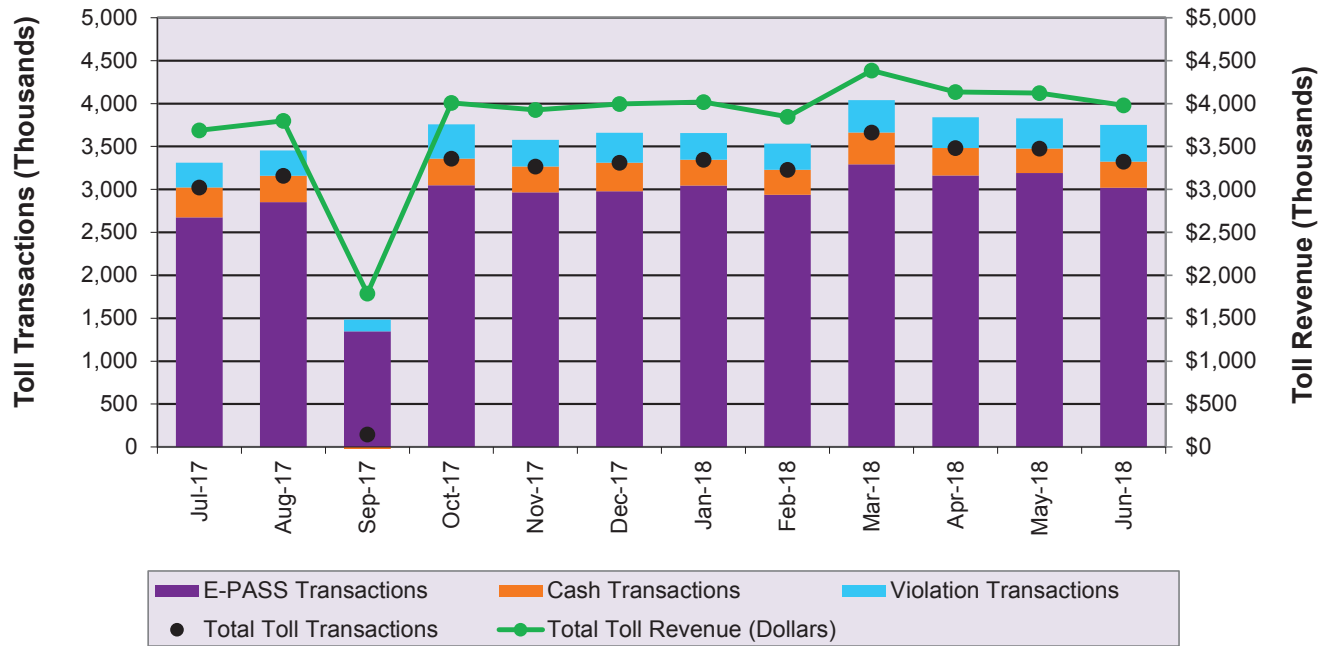

Month	FY 18 MONTHLY MAINLINE & RAMP TOLL TRANSACTIONS					Total Toll Revenue
	E-PASS	Cash	Total Revenue	Violations	Total	
Jul-17	2,673,986	349,053	3,023,039	287,449	3,310,488	\$3,688,450
Aug-17	2,852,131	306,979	3,159,110	295,887	3,454,997	\$3,799,949
Sep-17	1,347,409	-1,200,802	146,607	135,661	282,268	\$1,787,066
Oct-17	3,049,255	309,592	3,358,847	400,632	3,759,479	\$4,007,300
Nov-17	2,965,123	300,581	3,265,704	312,199	3,577,903	\$3,924,514
Dec-17	2,977,863	334,065	3,311,928	349,303	3,661,231	\$3,996,975
Jan-18	3,046,542	299,510	3,346,052	311,486	3,657,538	\$4,018,599
Feb-18	2,936,332	293,467	3,229,799	302,035	3,531,834	\$3,846,683
Mar-18	3,293,492	370,085	3,663,577	377,918	4,041,495	\$4,385,583
Apr-18	3,162,898	318,742	3,481,640	357,602	3,839,242	\$4,133,597
May-18	3,191,882	285,162	3,477,044	351,087	3,828,131	\$4,122,578
Jun-18	3,020,480	302,511	3,322,991	429,274	3,752,265	\$3,981,272
Yearly Totals	34,517,393	2,268,945	36,786,338	3,910,533	40,696,871	\$45,692,566

Note: Data includes ramp toll plazas that report to the Boggy Creek Mainline Toll Plaza.

1. Cash transactions are calculated as the difference between total revenue traffic and E-PASS traffic.
2. In FY 18, all plazas had tolls suspended from September 5, 2017 to September 21, 2017 due to Hurricane Irma.



Boggy Creek Mainline Toll Facility
SR 417 - Central Florida GreeneWay
Typical Daily Expressway Traffic Volumes - April 2018

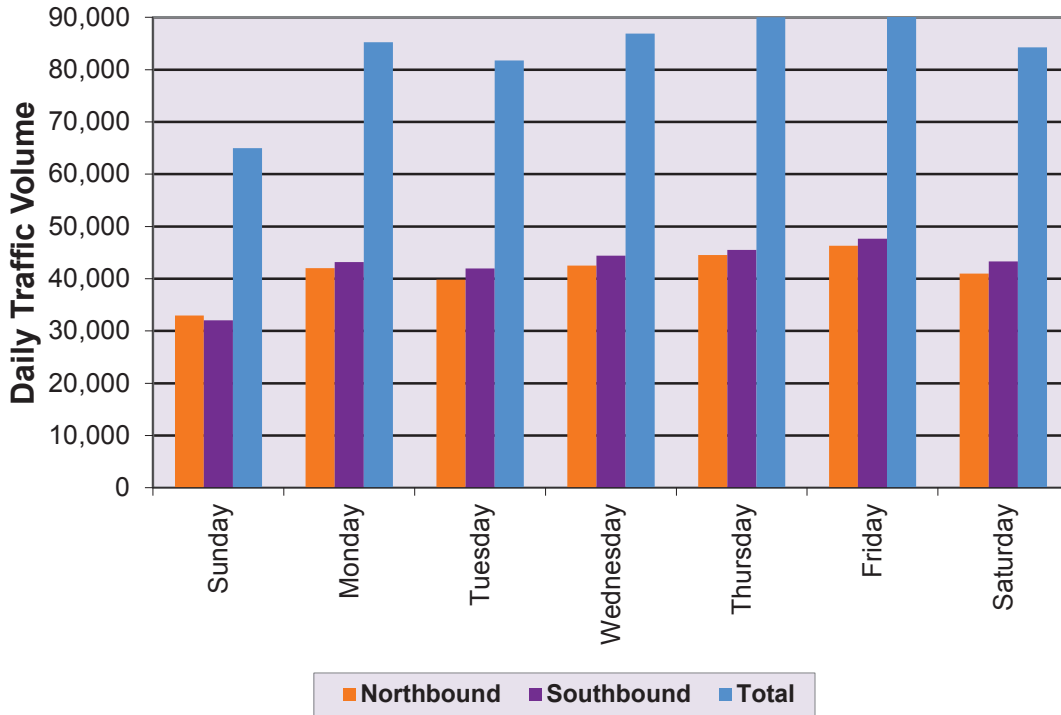

Day	Expressway Traffic Volumes		
	Northbound	Southbound	Total
Sunday	32,972	32,027	64,999
Monday	42,027	43,198	85,225
Tuesday	39,798	41,987	81,785
Wednesday	42,495	44,398	86,892
Thursday	44,517	45,511	90,028
Friday	46,282	47,657	93,939
Saturday	40,964	43,303	84,267



Boggy Creek Mainline Toll Facility
SR 417 - Central Florida GreenWay
Typical Average Five Day Hourly Traffic - April 2018

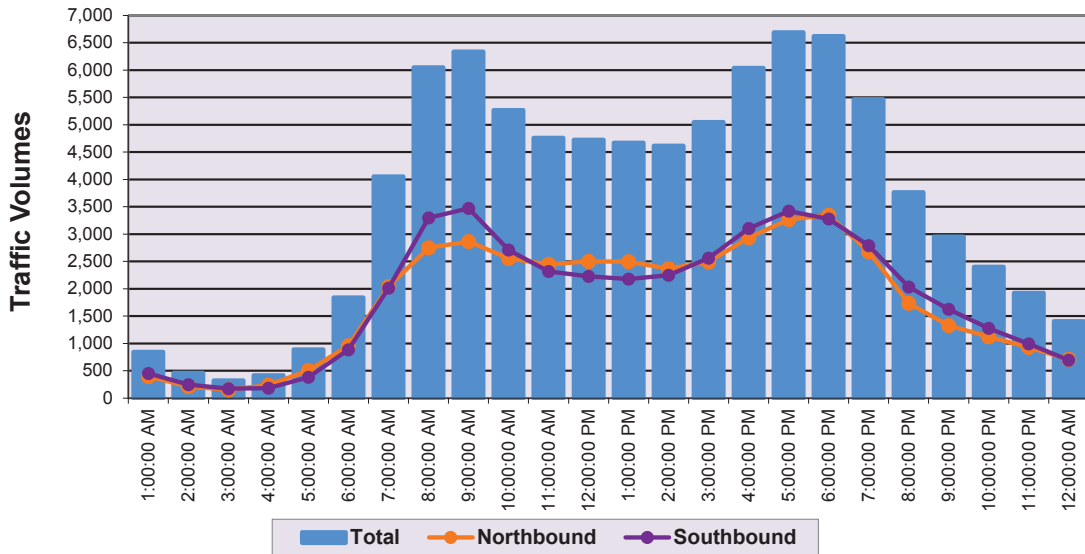

Hour Ending	Average Weekday Volumes		
	Northbound	Southbound	Total
1:00 AM	395	449	844
2:00 AM	214	246	460
3:00 AM	153	170	323
4:00 AM	235	182	417
5:00 AM	507	380	887
6:00 AM	956	885	1,841
7:00 AM	2,041	2,014	4,055
8:00 AM	2,751	3,297	6,047
9:00 AM	2,863	3,473	6,336
10:00 AM	2,558	2,708	5,266
11:00 AM	2,444	2,318	4,762
12:00 PM	2,499	2,228	4,727

Hour Ending	Average Weekday Volumes		
	Northbound	Southbound	Total
1:00 PM	2,496	2,177	4,673
2:00 PM	2,368	2,246	4,614
3:00 PM	2,490	2,562	5,051
4:00 PM	2,935	3,102	6,037
5:00 PM	3,269	3,420	6,689
6:00 PM	3,347	3,277	6,623
7:00 PM	2,677	2,791	5,469
8:00 PM	1,735	2,032	3,767
9:00 PM	1,329	1,627	2,955
10:00 PM	1,125	1,278	2,403
11:00 PM	927	995	1,922
12:00 AM	712	694	1,406

Total Northbound	43,024
Total Southbound	44,550
Total Weekday	87,574



Boggy Creek Mainline Toll Facility
SR 417 - Central Florida GreeneWay
 Typical Average Seven Day Hourly Traffic - April 2018

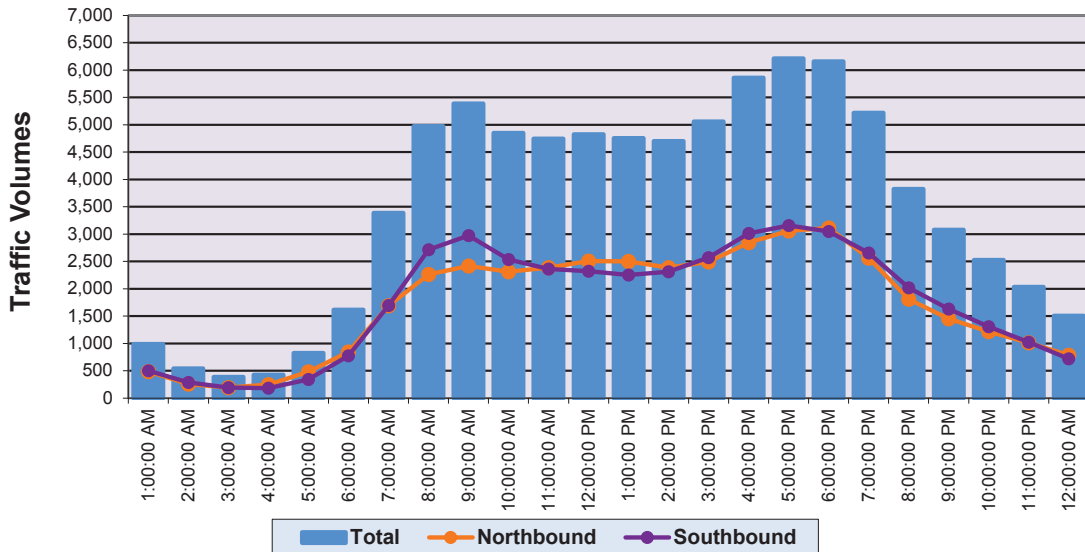

Hour Ending	Average Weekday Volumes		
	Northbound	Southbound	Total
1:00 AM	487	499	986
2:00 AM	257	285	542
3:00 AM	192	194	386
4:00 AM	245	183	428
5:00 AM	480	344	824
6:00 AM	842	772	1,614
7:00 AM	1,690	1,695	3,385
8:00 AM	2,261	2,714	4,974
9:00 AM	2,416	2,973	5,389
10:00 AM	2,312	2,536	4,848
11:00 AM	2,386	2,362	4,747
12:00 PM	2,506	2,320	4,826

Hour Ending	Average Weekday Volumes		
	Northbound	Southbound	Total
1:00 PM	2,501	2,253	4,754
2:00 PM	2,386	2,314	4,700
3:00 PM	2,489	2,568	5,057
4:00 PM	2,845	3,014	5,859
5:00 PM	3,057	3,157	6,214
6:00 PM	3,112	3,047	6,159
7:00 PM	2,559	2,657	5,216
8:00 PM	1,807	2,019	3,826
9:00 PM	1,450	1,629	3,079
10:00 PM	1,218	1,308	2,526
11:00 PM	1,011	1,024	2,035
12:00 AM	785	718	1,503

Total Northbound	41,293
Total Southbound	42,583
Total Weekday	83,876



Boggy Creek Mainline Toll Facility

Toll Facility Peak Hour Characteristic Summary Typical Average Weekday (Monday through Friday) - April 2018

Average Weekday Traffic Summary (unadjusted)

Average Weekday Total Traffic	87,574
Northbound Directional Traffic	43,024
Southbound Directional Traffic	44,550

Morning Peak Hour Summary (7:00 a.m. to 8:00 a.m.)

Northbound Directional Traffic	2,863
Southbound Directional Traffic	3,473
Total AM Peak Hour Traffic	6,336

AM Peak Hour Factor ("K") = Total Peak Hour Traffic / Average Weekday Total Traffic

AM Peak Hour Factor ("K_{am}") 7.23%

AM Peak Hour Directional Factor ("D") = Peak Directional Traffic / Total Peak Hour Traffic

AM Peak Hour Directional Factor ("D_{am}") 54.81%

Evening Peak Hour Summary (5:00 p.m. to 6:00 p.m.)

Northbound Directional Traffic	3,347
Southbound Directional Traffic	3,277
Total PM Peak Hour Traffic	6,623

PM Peak Hour Factor ("K") = Total Peak Hour Traffic / Average Weekday Total Traffic

PM Peak Hour Factor ("K_{pm}") 7.56%

PM Peak Hour Directional Factor ("D") = Peak Directional Traffic / Total Peak Hour Traffic

PM Peak Hour Directional Factor ("D_{pm}") 50.53%



Boggy Creek Mainline Toll Facility

Toll Transaction Summary

Typical Average Weekday (Monday through Friday) - April 2018

Average Weekday Summary

Direction of Travel	E-PASS (AVI)		ACM (Coin)		Manual (Cash)		Total	
	Volume	% Usage	Volume	% Usage	Volume	% Usage	Traffic	% Usage
Northbound	37,995	89%	671	2%	4,129	10%	42,796	100%
Southbound	39,692	90%	594	1%	4,008	9%	44,294	100%

Morning Peak Hour Summary (7:00 a.m. to 8:00 a.m.)

Direction of Travel	E-PASS (AVI)		ACM (Coin)		Manual (Cash)		Total	
	Volume	% Usage	Volume	% Usage	Volume	% Usage	Traffic	% Usage
Northbound	2,572	90%	45	2%	236	8%	2,853	100%
Southbound	3,261	95%	28	1%	161	5%	3,450	100%

Evening Peak Hour Summary (5:00 p.m. to 6:00 p.m.)

Direction of Travel	E-PASS (AVI)		ACM (Coin)		Manual (Cash)		Total	
	Volume	% Usage	Volume	% Usage	Volume	% Usage	Traffic	% Usage
Northbound	3,043	92%	43	1%	238	7%	3,325	100%
Southbound	2,824	87%	56	2%	380	12%	3,259	100%



Boggy Creek Mainline Toll Facility
SR 417 - Central Florida GreeneWay
Historical & Existing Total Revenue Transactions Statistics

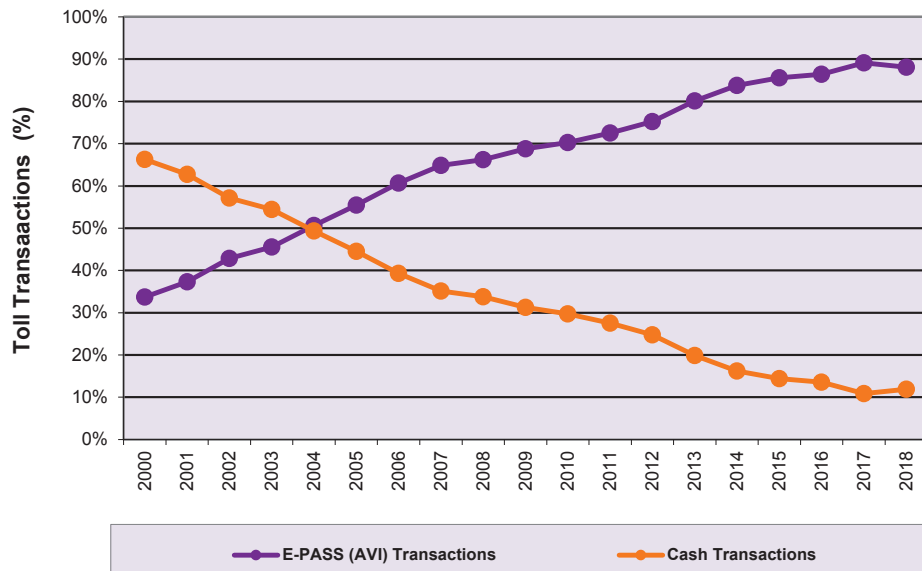

Year	Yearly Revenue Transaction		% Violations ⁽²⁾ (Percent of Total Transactions)
	% E-PASS (AVI) Transactions	% Cash Transactions	
2000	33.7%	66.3%	2.5%
2001	37.3%	62.7%	2.4%
2002	42.8%	57.2%	1.8%
2003	45.5%	54.5%	1.6%
2004	50.6%	49.4%	1.8%
2005	55.4%	44.6%	2.3%
2006	60.7%	39.3%	2.8%
2007	64.9%	35.1%	2.8%
2008	66.2%	33.8%	3.2%
2009	68.8%	31.2%	2.9%
2010	70.3%	29.7%	2.7%
2011	72.5%	27.5%	2.6%
2012	75.2%	24.8%	2.9%
2013	80.1%	19.9%	3.3%
2014	83.8%	16.2%	4.3%
2015	85.6%	14.4%	5.2%
2016	86.4%	13.6%	6.0%
2017	89.1%	10.9%	13.0%
2018	88.1%	11.9%	12.9%

1. In FY 18, all plazas had tolls suspended from September 5, 2017 to September 21, 2017 due to Hurricane Irma.
2. Calculated as percentage of Total Transactions, which is equal to Revenue Transactions plus Violations.



Curry Ford Mainline Toll Facility (Central Florida GreeneWay)



2018 Traffic Data and Statistics Manual
CENTRAL FLORIDA EXPRESSWAY AUTHORITY

OSCEOLA

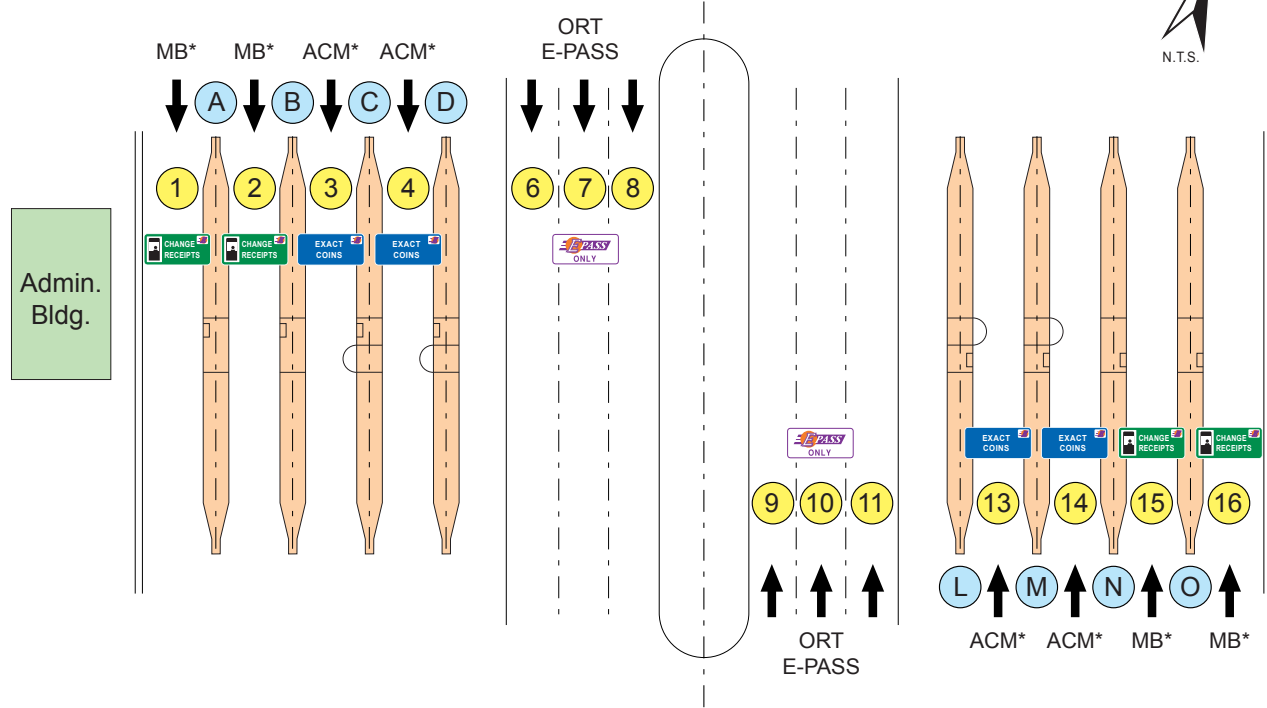

HISTORIC TRAFFIC - A.A.W.T.

1992	9,950 (Post Toll)	2001	44,290	2010	63,160
1993	13,550	2002	50,200	2011	62,530
1994	17,810	2003	54,760	2012	64,950 (Toll Increase July 2012)
1995	21,810	2004	67,010	2013	66,820
1996	26,780	2005	69,900	2014	73,770
1997	27,880	2006	74,300	2015	86,030
1998	33,530	2007	76,100	2016	97,280
1999	39,270	2008	68,900	2017	105,660
2000	42,460	2009	63,300 (Toll Increase April 2009)	2018	117,750 (Toll Increase July 2018)

TOLL RATE STRUCTURE

	<u>E-PASS</u>	<u>CASH</u>
2 Axles	\$.86	\$ 1.00
3 Axles	\$ 1.71	\$ 2.00
4 Axles	\$ 1.99	\$ 2.25
5 Axles or more	\$ 2.57	\$ 3.00

(Toll Rates Effective July 1, 2019)

LANES OF EQUIPMENT

- 4 Manned Booths (MB) with E-PASS
- 4 Booths with Automatic Coin Machines (ACM) and E-PASS
- 6 Open Road Tolling (ORT) E-PASS
- * Changeable Message Sign

LEGEND

- ① Lane Number
- Ⓐ Island Designation



**SR 417 (CENTRAL FLORIDA GREENEWAY)
Curry Ford Mainline Toll Facility**

SECTION III



Approx. Scale: 1" = 200'
January 2018

Curry Ford Mainline Toll Facility SR 417 - Central Florida GreenWay

Fiscal Year 2018 Monthly Mainline & Ramp Toll Transactions and Revenue Summary

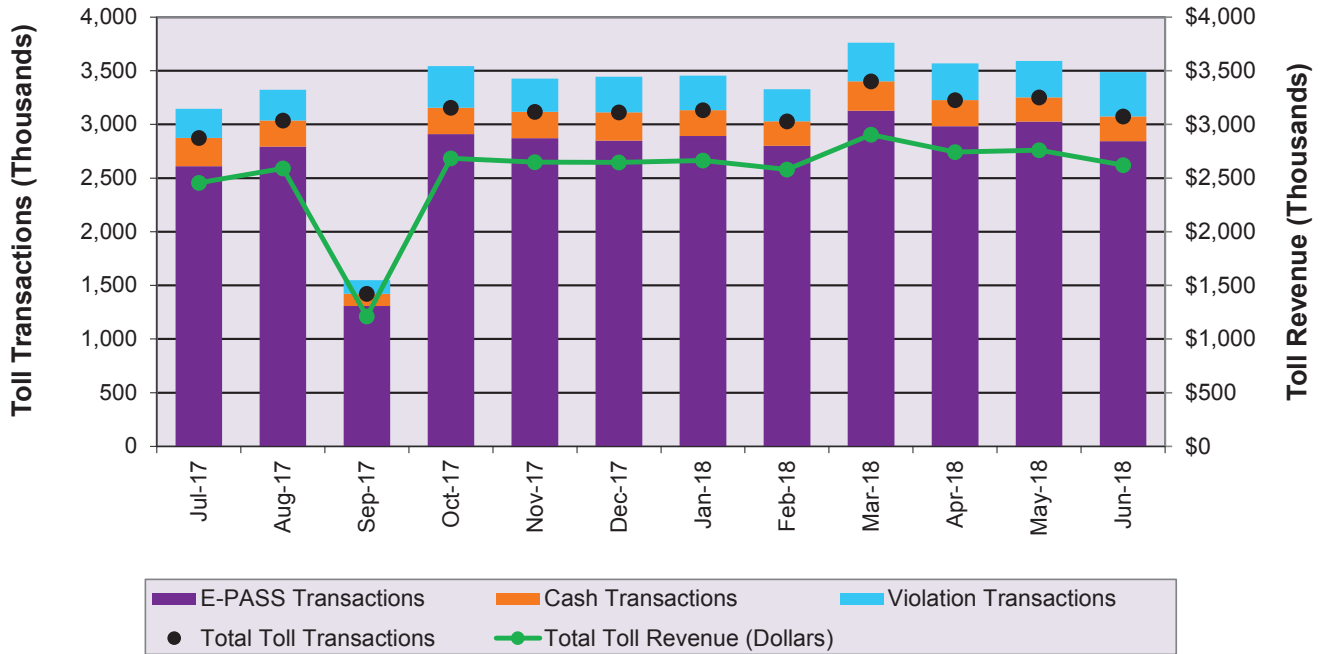

Month	FY 18 MONTHLY MAINLINE & RAMP TOLL TRANSACTIONS					Total Toll Revenue
	E-PASS	Cash	Total Revenue	Violations	Total	
July-17	2,611,154	263,443	2,874,597	270,675	3,145,272	\$2,456,119
August-17	2,791,917	244,849	3,036,766	285,779	3,322,545	\$2,590,446
September-17	1,308,688	112,154	1,420,842	128,146	1,548,988	\$1,210,293
October-17	2,908,325	247,889	3,156,214	387,532	3,543,746	\$2,685,008
November-17	2,872,195	244,198	3,116,393	309,925	3,426,318	\$2,648,932
December-17	2,847,687	263,503	3,111,190	332,627	3,443,817	\$2,645,403
January-18	2,891,841	239,399	3,131,240	323,961	3,455,201	\$2,663,509
February-18	2,800,136	229,231	3,029,367	298,609	3,327,976	\$2,579,703
March-18	3,126,423	274,111	3,400,534	360,751	3,761,285	\$2,903,778
April-18	2,983,721	241,278	3,224,999	344,033	3,569,032	\$2,742,464
May-18	3,026,992	225,214	3,252,206	339,032	3,591,238	\$2,759,423
June-18	2,843,479	231,871	3,075,350	412,185	3,487,535	\$2,620,979
Yearly Totals	33,012,558	2,817,140	35,829,698	3,793,255	39,622,953	\$30,506,057

Note: Data includes ramp toll plazas that report to the Curry Ford Mainline Toll Plaza.

1. Cash transactions are calculated as the difference between total revenue traffic and E-PASS traffic.
2. In FY 18, all plazas had tolls suspended from September 5, 2017 to September 21, 2017 due to Hurricane Irma.



Curry Ford Mainline Toll Facility
SR 417 - Central Florida GreeneWay
 Typical Daily Traffic Volumes - April 2018

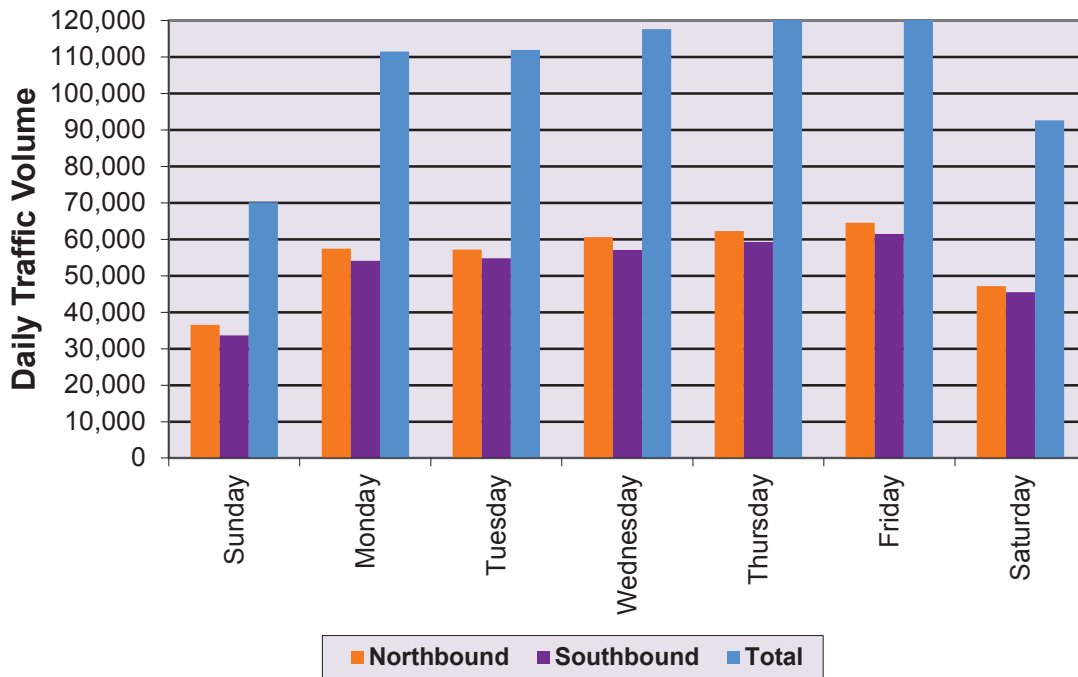

Day	Expressway Traffic Volumes		
	Northbound	Southbound	Total
Sunday	36,537	33,662	70,199
Monday	57,429	54,099	111,528
Tuesday	57,141	54,774	111,914
Wednesday	60,578	57,121	117,699
Thursday	62,267	59,331	121,598
Friday	64,534	61,464	125,998
Saturday	47,217	45,467	92,684



Curry Ford Mainline Toll Facility
SR 417 - Central Florida GreenWay
Average Five Day Hourly Traffic - April 2018

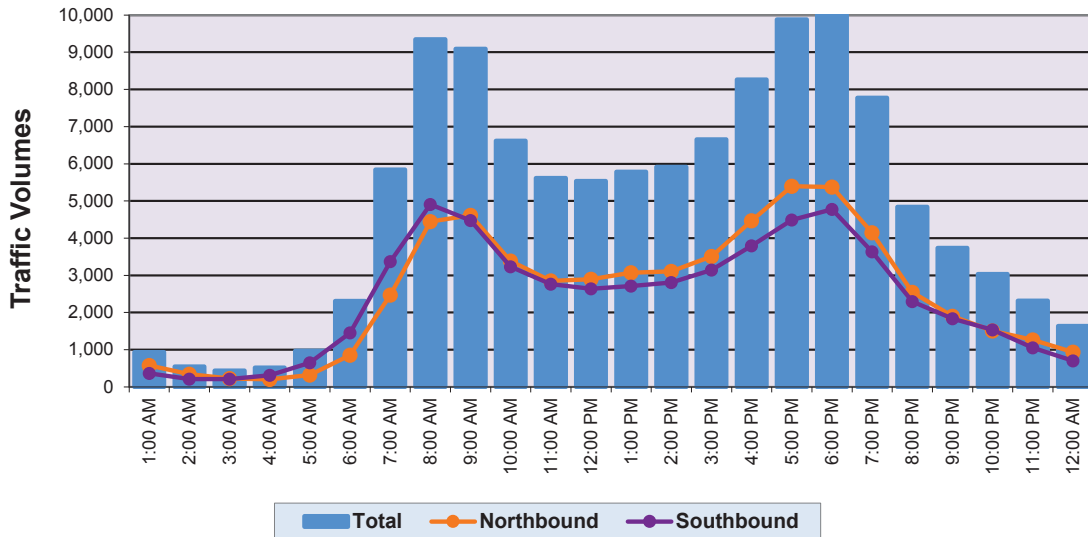

Hour Ending	Average Weekday Volumes		
	Northbound	Southbound	Total
1:00 AM	575	360	935
2:00 AM	341	209	550
3:00 AM	227	213	440
4:00 AM	202	314	516
5:00 AM	317	651	968
6:00 AM	853	1,457	2,310
7:00 AM	2,471	3,369	5,840
8:00 AM	4,443	4,907	9,349
9:00 AM	4,614	4,475	9,090
10:00 AM	3,384	3,232	6,616
11:00 AM	2,854	2,763	5,617
12:00 PM	2,898	2,640	5,538

Hour Ending	Average Weekday Volumes		
	Northbound	Southbound	Total
1:00 PM	3,070	2,715	5,784
2:00 PM	3,109	2,810	5,918
3:00 PM	3,507	3,145	6,652
4:00 PM	4,471	3,791	8,263
5:00 PM	5,394	4,487	9,881
6:00 PM	5,373	4,772	10,146
7:00 PM	4,144	3,634	7,778
8:00 PM	2,544	2,295	4,840
9:00 PM	1,897	1,836	3,733
10:00 PM	1,504	1,533	3,037
11:00 PM	1,264	1,050	2,314
12:00 AM	936	698	1,634

Total Northbound	60,390
Total Southbound	57,358
Total Weekday	117,747



Curry Ford Mainline Toll Facility
SR 417 - Central Florida GreeneWay
Average Seven Day Hourly Traffic - April 2018

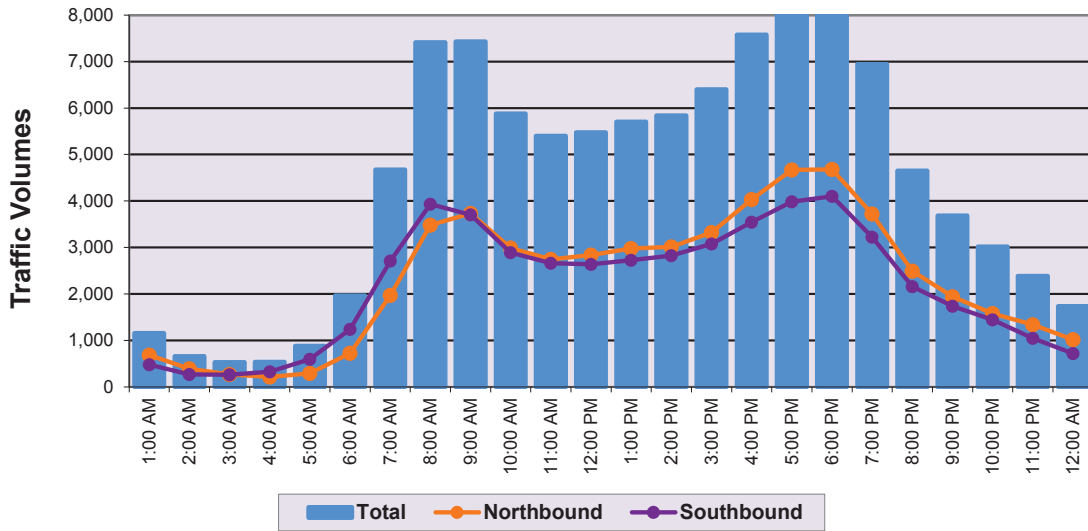

Hour Ending	Average Weekday Volumes		
	Northbound	Southbound	Total
1:00 AM	681	476	1,157
2:00 AM	393	268	661
3:00 AM	270	259	529
4:00 AM	212	324	536
5:00 AM	289	594	883
6:00 AM	725	1,237	1,962
7:00 AM	1,968	2,707	4,675
8:00 AM	3,483	3,928	7,411
9:00 AM	3,733	3,701	7,434
10:00 AM	2,991	2,891	5,882
11:00 AM	2,740	2,660	5,400
12:00 PM	2,836	2,638	5,474

Hour Ending	Average Weekday Volumes		
	Northbound	Southbound	Total
1:00 PM	2,980	2,727	5,706
2:00 PM	3,011	2,825	5,836
3:00 PM	3,321	3,078	6,399
4:00 PM	4,031	3,544	7,576
5:00 PM	4,669	3,986	8,655
6:00 PM	4,678	4,101	8,780
7:00 PM	3,721	3,224	6,945
8:00 PM	2,489	2,159	4,648
9:00 PM	1,944	1,739	3,683
10:00 PM	1,578	1,443	3,021
11:00 PM	1,339	1,047	2,386
12:00 AM	1,018	717	1,735

Total Northbound	55,100
Total Southbound	52,274
Total Weekday	107,374



SR 417 (CENTRAL FLORIDA GREENEWAY)
Curry Ford Mainline Toll Facility

Curry Ford Mainline Toll Facility

Toll Facility Peak Hour Characteristic Summary Typical Average Weekday (Monday through Friday) - April 2018

Average Weekday Traffic Summary (unadjusted)

Average Weekday Total Traffic	117,747
Northbound Directional Traffic	60,390
Southbound Directional Traffic	57,358

Morning Peak Hour Summary (7:00 a.m. to 8:00 a.m.)

Northbound Directional Traffic	4,443
Southbound Directional Traffic	4,907
Total AM Peak Hour Traffic	9,349

AM Peak Hour Factor ("K") = Total Peak Hour Traffic / Average Weekday Total Traffic

AM Peak Hour Factor ("K_{am}") 7.94%

AM Peak Hour Directional Factor ("D") = Peak Directional Traffic / Total Peak Hour Traffic

AM Peak Hour Directional Factor ("D_{am}") 52.48%

Evening Peak Hour Summary (5:00 p.m. to 6:00 p.m.)

Northbound Directional Traffic	5,373
Southbound Directional Traffic	4,772
Total PM Peak Hour Traffic	10,146

PM Peak Hour Factor ("K") = Total Peak Hour Traffic / Average Weekday Total Traffic

PM Peak Hour Factor ("K_{pm}") 8.62%

PM Peak Hour Directional Factor ("D") = Peak Directional Traffic / Total Peak Hour Traffic

PM Peak Hour Directional Factor ("D_{pm}") 52.96%



Curry Ford Mainline Toll Facility

Toll Transaction Summary

Typical Average Weekday (Monday through Friday) - April 2018

Average Weekday Summary

Direction of Travel	E-PASS (AVI)		ACM (Coin)		Manual (Cash)		Total	
	Volume	% Usage	Volume	% Usage	Volume	% Usage	Traffic	% Usage
Northbound	55,758	93%	1,002	2%	3,150	5%	59,910	100%
Southbound	53,279	94%	785	1%	2,824	5%	56,888	100%

Morning Peak Hour Summary (7:00 a.m. to 8:00 a.m.)

Direction of Travel	E-PASS (AVI)		ACM (Coin)		Manual (Cash)		Total	
	Volume	% Usage	Volume	% Usage	Volume	% Usage	Traffic	% Usage
Northbound	4,233	96%	30	1%	138	3%	4,400	100%
Southbound	4,661	96%	41	1%	168	3%	4,869	100%

Evening Peak Hour Summary (5:00 p.m. to 6:00 p.m.)

Direction of Travel	E-PASS (AVI)		ACM (Coin)		Manual (Cash)		Total	
	Volume	% Usage	Volume	% Usage	Volume	% Usage	Traffic	% Usage
Northbound	5,028	94%	80	2%	228	4%	5,336	100%
Southbound	4,448	94%	69	1%	218	5%	4,734	100%



Curry Ford Mainline Toll Facility
SR 417 - Central Florida GreenWay
Historical & Existing Total Revenue Transactions Statistics

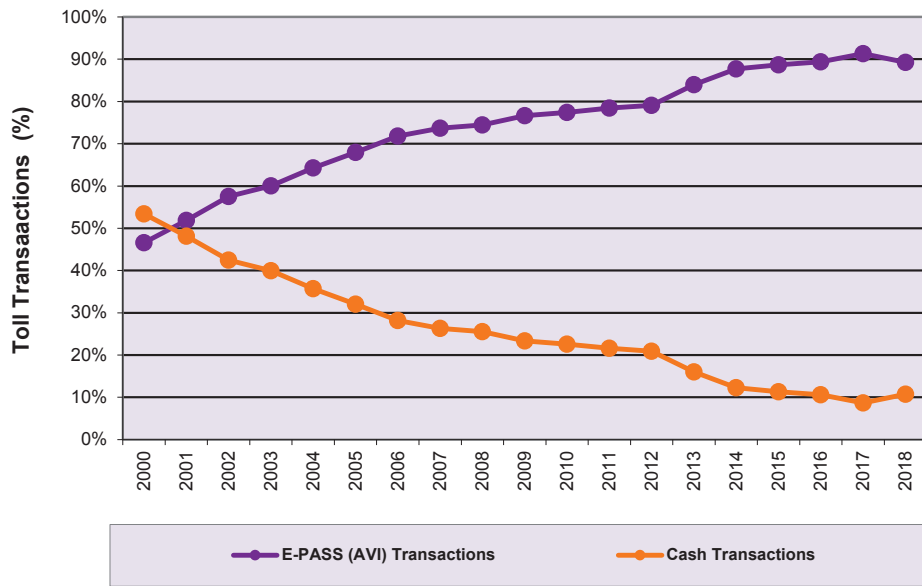

Year	Yearly Revenue Transaction		% Violations ⁽²⁾ (Percent of Total Transactions)
	% E-PASS (AVI) Transactions	% Cash Transactions	
2000	46.6%	53.4%	2.5%
2001	51.8%	48.2%	2.1%
2002	57.5%	42.5%	1.5%
2003	60.0%	40.0%	1.8%
2004	64.3%	35.7%	2.2%
2005	67.9%	32.1%	2.9%
2006	71.8%	28.2%	2.6%
2007	73.7%	26.3%	2.4%
2008	74.4%	25.6%	2.4%
2009	76.7%	23.3%	5.0%
2010	77.4%	22.6%	2.6%
2011	78.4%	21.6%	2.8%
2012	79.1%	20.9%	3.2%
2013	84.0%	16.0%	3.6%
2014	87.7%	12.3%	4.5%
2015	88.7%	11.3%	5.3%
2016	89.4%	10.6%	6.2%
2017	91.3%	8.7%	8.5%
2018	89.3%	10.7%	13.2%

1. In FY 18, all plazas had tolls suspended from September 5, 2017 to September 21, 2017 due to Hurricane Irma.
2. Calculated as percentage of Total Transactions, which is equal to Revenue Transactions plus Violations.



University Mainline Toll Facility (Central Florida GreeneWay)



2018 Traffic Data and Statistics Manual
CENTRAL FLORIDA EXPRESSWAY AUTHORITY

OSCEOLA

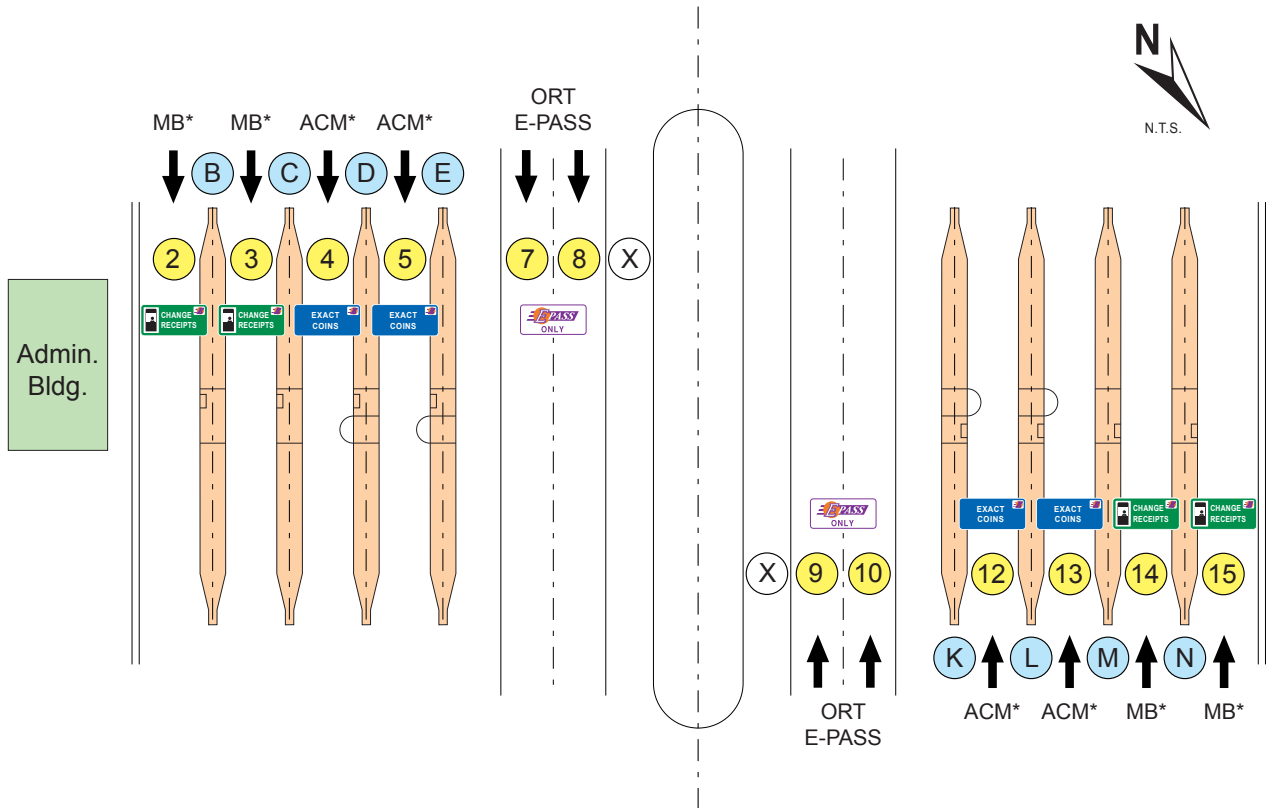

HISTORIC TRAFFIC - A.A.W.T.

1992	15,910 (<i>Post Toll</i>)	2001	56,370	2010	72,900
1993	19,370	2002	60,650	2011	74,900
1994	26,420	2003	68,590	2012	72,750 (<i>Toll Increase July 2012</i>)
1995	31,500	2004	77,940	2013	71,670
1996	37,300	2005	79,700	2014	74,080
1997	38,730	2006	81,600	2015	86,650
1998	44,610	2007	82,800	2016	95,670
1999	49,900	2008	75,600	2017	103,030
2000	53,240	2009	70,500 (<i>Toll Increase April 2009</i>)	2018	110,100 (<i>Toll Increase July 2018</i>)

TOLL RATE STRUCTURE

	<u>E-PASS</u>	<u>CASH</u>
2 Axles	\$.86	\$ 1.00
3 Axles	\$ 1.71	\$ 2.00
4 Axles	\$ 1.99	\$ 2.25
5 Axles or more	\$ 2.57	\$ 3.00

(Toll Rates Effective July 1, 2019)

LANES OF EQUIPMENT

- 4 Manned Booths (MB) with E-PASS
- 4 Booths with Automatic Coin Machines (ACM) and E-PASS
- 4 Open Road Tolling (ORT) E-PASS
- * Changeable Message Sign

LEGEND

- ① Lane Number
- Ⓐ Island Designation
- ⓧ Under Construction by 417-134



Approx. Scale: 1" = 200'
January 2018



**SR 417 (CENTRAL FLORIDA GREENEWAY)
University Mainline Toll Facility**

SECTION III

136

University Mainline Toll Facility

SR 417 - Central Florida GreeneWay

Fiscal Year 2018 Monthly Mainline & Ramp Toll Transactions and Revenue Summary

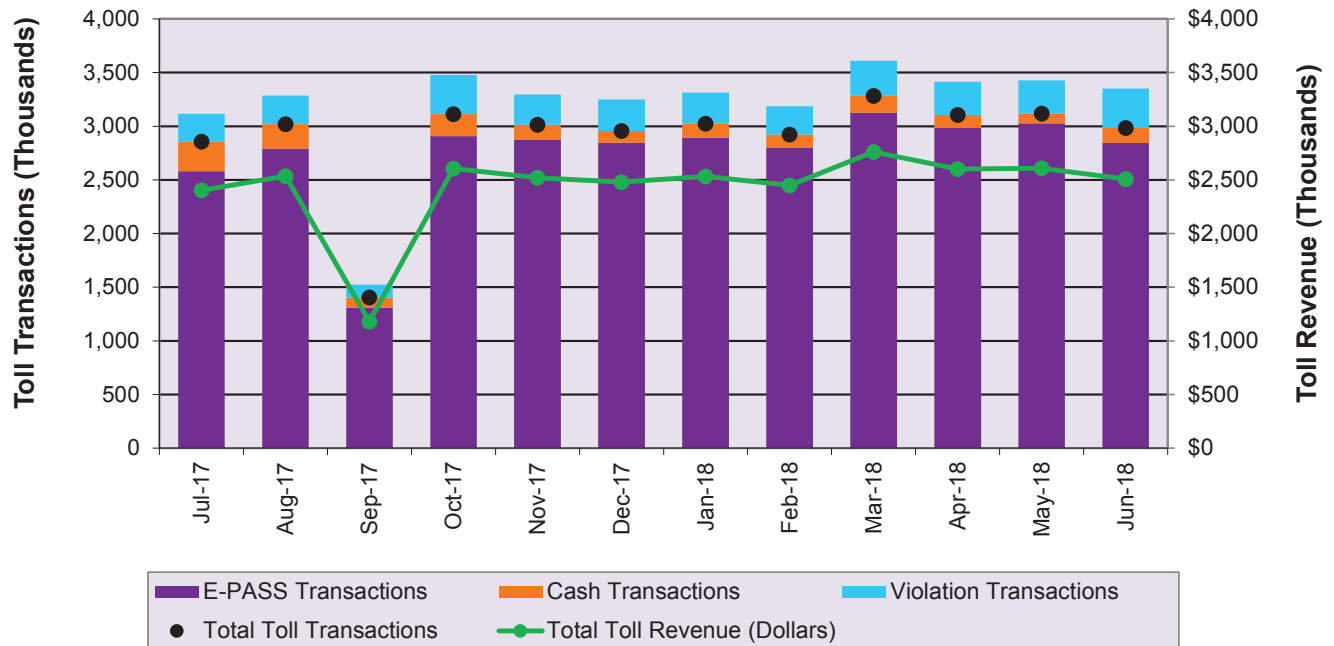

Month	FY 18 MONTHLY MAINLINE & RAMP TOLL TRANSACTIONS					Total Toll Revenue
	E-PASS	Cash	Total Revenue	Violations	Total	
July-17	2,581,016	276,904	2,857,920	257,477	3,115,397	\$2,404,022
August-17	2,791,917	228,277	3,020,194	264,280	3,284,474	\$2,536,018
September-17	1,308,688	95,914	1,404,602	120,224	1,524,826	\$1,177,829
October-17	2,908,325	204,173	3,112,498	364,370	3,476,868	\$2,605,259
November-17	2,872,195	141,106	3,013,301	282,965	3,296,266	\$2,520,303
December-17	2,847,687	108,092	2,955,779	293,563	3,249,342	\$2,479,245
January-18	2,891,841	132,153	3,023,994	289,477	3,313,471	\$2,531,404
February-18	2,800,136	121,618	2,921,754	265,036	3,186,790	\$2,448,873
March-18	3,126,423	155,177	3,281,600	327,751	3,609,351	\$2,759,515
April-18	2,983,721	120,787	3,104,508	311,123	3,415,631	\$2,602,033
May-18	3,026,992	91,940	3,118,932	307,121	3,426,053	\$2,608,732
June-18	2,843,479	140,322	2,983,801	367,853	3,351,654	\$2,506,229
Yearly Totals	32,982,420	1,816,463	34,798,883	3,451,240	38,250,123	\$29,179,462

Note: Data includes ramp toll plazas that report to the University Mainline Toll Plaza.

1. Cash transactions are calculated as the difference between total revenue traffic and E-PASS traffic.

2. In FY 18, all plazas had tolls suspended from September 5, 2017 to September 21, 2017 due to Hurricane Irma.



University Mainline Toll Facility
SR 417 - Central Florida GreeneWay
Typical Daily Expressway Traffic Volumes - April 2018

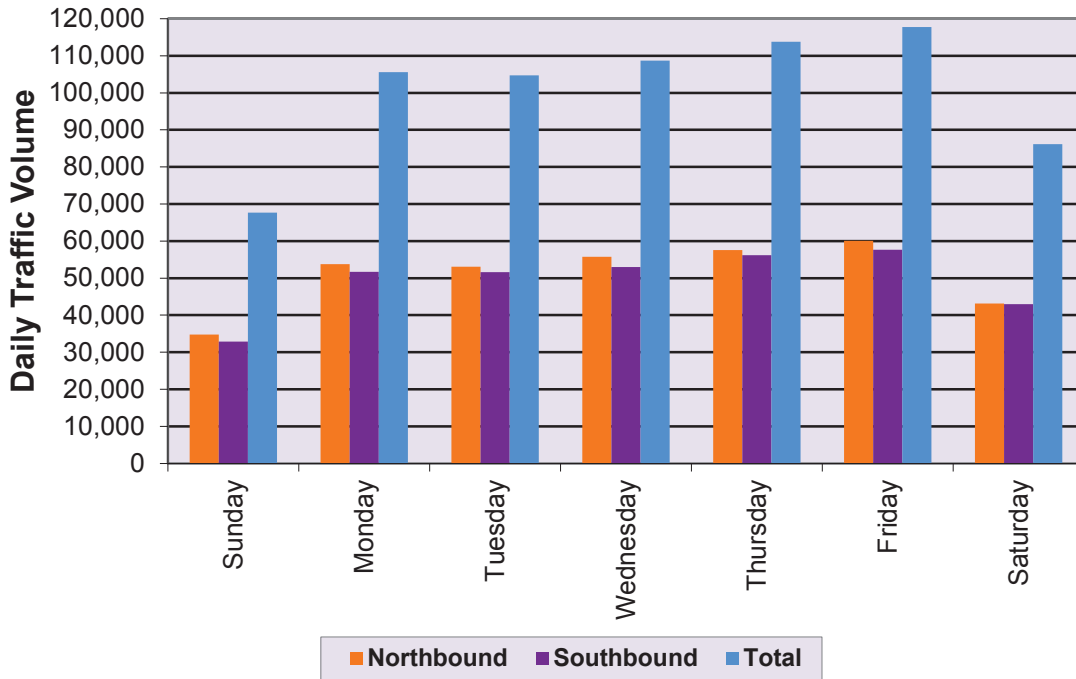

Day	Expressway Traffic Volumes		
	Northbound	Southbound	Total
Sunday	34,770	32,885	67,655
Monday	53,810	51,737	105,547
Tuesday	53,042	51,643	104,685
Wednesday	55,773	52,953	108,726
Thursday	57,596	56,195	113,791
Friday	60,114	57,617	117,731
Saturday	43,136	43,015	86,150

University Mainline Toll Facility
SR 417 - Central Florida GreeneWay
 Typical Average Five Day Hourly Traffic - April 2018

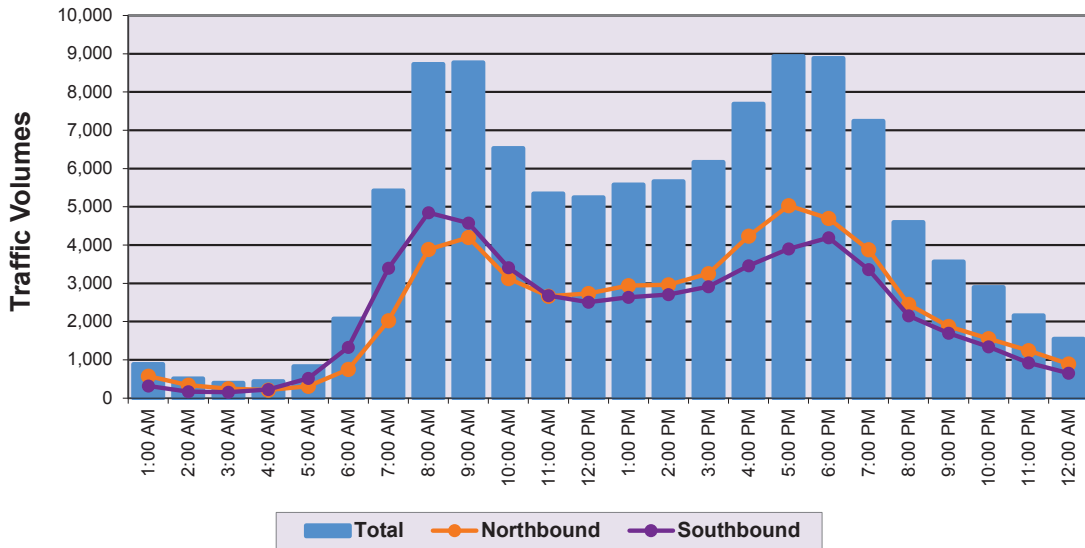

Hour Ending	Average Weekday Volumes		
	Northbound	Southbound	Total
1:00 AM	571	316	887
2:00 AM	337	170	507
3:00 AM	243	156	398
4:00 AM	214	222	436
5:00 AM	313	520	833
6:00 AM	748	1,326	2,074
7:00 AM	2,022	3,396	5,418
8:00 AM	3,884	4,845	8,729
9:00 AM	4,199	4,573	8,772
10:00 AM	3,123	3,408	6,531
11:00 AM	2,662	2,679	5,340
12:00 PM	2,738	2,508	5,246

Hour Ending	Average Weekday Volumes		
	Northbound	Southbound	Total
1:00 PM	2,943	2,636	5,579
2:00 PM	2,959	2,706	5,665
3:00 PM	3,256	2,912	6,169
4:00 PM	4,233	3,459	7,691
5:00 PM	5,034	3,901	8,935
6:00 PM	4,698	4,188	8,886
7:00 PM	3,880	3,359	7,239
8:00 PM	2,450	2,148	4,598
9:00 PM	1,872	1,694	3,566
10:00 PM	1,554	1,341	2,895
11:00 PM	1,241	919	2,160
12:00 AM	895	648	1,544

Total Northbound	56,067
Total Southbound	54,029
Total Weekday	110,096



University Mainline Toll Facility
SR 417 - Central Florida GreenWay
 Typical Average Seven Day Hourly Traffic - April 2018

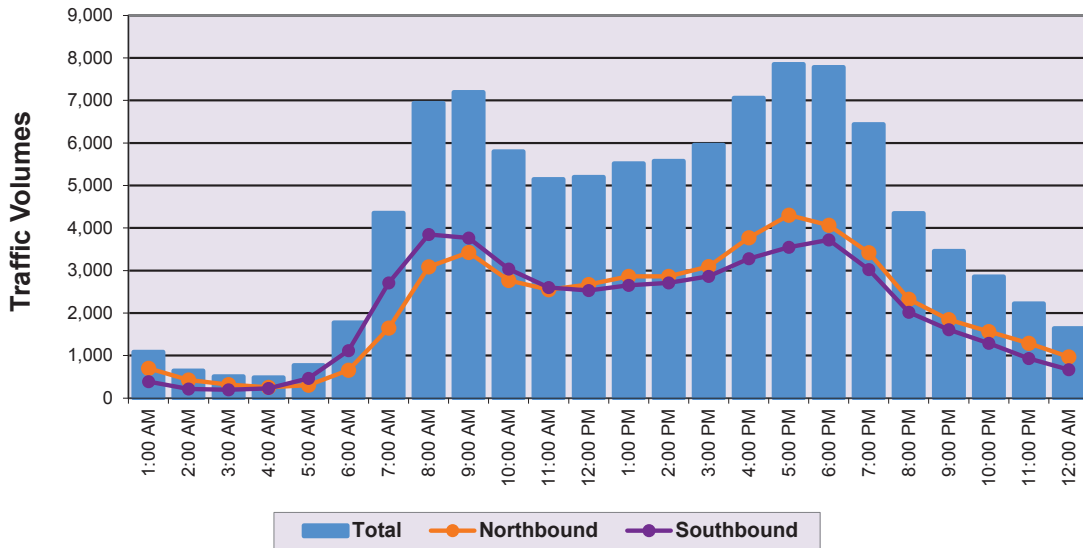

Hour Ending	Average Weekday Volumes		
	Northbound	Southbound	Total
1:00 AM	700	387	1,087
2:00 AM	424	218	641
3:00 AM	316	194	510
4:00 AM	252	230	482
5:00 AM	304	468	771
6:00 AM	659	1,117	1,776
7:00 AM	1,646	2,708	4,354
8:00 AM	3,086	3,851	6,937
9:00 AM	3,427	3,767	7,195
10:00 AM	2,766	3,037	5,803
11:00 AM	2,549	2,600	5,150
12:00 PM	2,673	2,529	5,202

Hour Ending	Average Weekday Volumes		
	Northbound	Southbound	Total
1:00 PM	2,865	2,654	5,519
2:00 PM	2,865	2,711	5,576
3:00 PM	3,091	2,865	5,956
4:00 PM	3,775	3,283	7,058
5:00 PM	4,304	3,547	7,851
6:00 PM	4,064	3,720	7,784
7:00 PM	3,418	3,021	6,439
8:00 PM	2,326	2,019	4,345
9:00 PM	1,844	1,612	3,456
10:00 PM	1,565	1,293	2,857
11:00 PM	1,288	935	2,223
12:00 AM	970	671	1,641

Total Northbound	51,177
Total Southbound	49,435
Total Weekday	100,612



University Mainline Toll Facility

Toll Facility Peak Hour Characteristic Summary Typical Average Weekday (Monday through Friday) - April 2018

Average Weekday Traffic Summary (unadjusted)

Average Weekday Total Traffic	110,096
Northbound Directional Traffic	56,067
Southbound Directional Traffic	54,029

Morning Peak Hour Summary (7:00 a.m. to 8:00 a.m.)

Northbound Directional Traffic	4,199
Southbound Directional Traffic	4,573
Total AM Peak Hour Traffic	8,772

AM Peak Hour Factor ("K") = Total Peak Hour Traffic / Average Weekday Total Traffic

AM Peak Hour Factor ("K_{am}") **7.97%**

AM Peak Hour Directional Factor ("D") = Peak Directional Traffic / Total Peak Hour Traffic

AM Peak Hour Directional Factor ("D_{am}") **52.13%**

Evening Peak Hour Summary (5:00 p.m. to 6:00 p.m.)

Northbound Directional Traffic	4,698
Southbound Directional Traffic	4,188
Total PM Peak Hour Traffic	8,886

PM Peak Hour Factor ("K") = Total Peak Hour Traffic / Average Weekday Total Traffic

PM Peak Hour Factor ("K_{pm}") **8.07%**

PM Peak Hour Directional Factor ("D") = Peak Directional Traffic / Total Peak Hour Traffic

PM Peak Hour Directional Factor ("D_{pm}") **52.87%**



University Mainline Toll Facility

Toll Transaction Summary

Typical Average Weekday (Monday through Friday) - April 2018

Average Weekday Summary

Direction of Travel	E-PASS (AVI)		ACM (Coin)		Manual (Cash)		Total	
	Volume	% Usage	Volume	% Usage	Volume	% Usage	Traffic	% Usage
Northbound	51,639	93%	891	2%	3,108	6%	55,638	100%
Southbound	50,100	93%	760	1%	2,752	5%	53,612	100%

Morning Peak Hour Summary (7:00 a.m. to 8:00 a.m.)

Direction of Travel	E-PASS (AVI)		ACM (Coin)		Manual (Cash)		Total	
	Volume	% Usage	Volume	% Usage	Volume	% Usage	Traffic	% Usage
Northbound	3,954	95%	48	1%	179	4%	4,181	100%
Southbound	4,336	96%	45	1%	157	3%	4,538	100%

Evening Peak Hour Summary (5:00 p.m. to 6:00 p.m.)

Direction of Travel	E-PASS (AVI)		ACM (Coin)		Manual (Cash)		Total	
	Volume	% Usage	Volume	% Usage	Volume	% Usage	Traffic	% Usage
Northbound	4,397	94%	59	1%	201	4%	4,657	100%
Southbound	3,878	93%	71	2%	208	5%	4,157	100%



University Mainline Toll Facility
SR 417 - Central Florida GreenWay
Historical & Existing Total Revenue Transactions Statistics

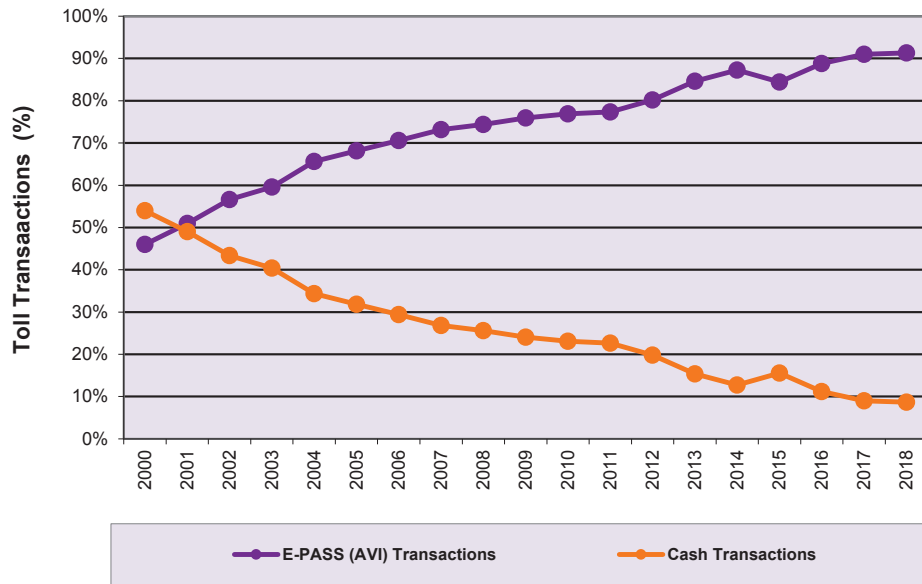

Year	Yearly Revenue Transaction		% Violations ⁽²⁾ (Percent of Total Transactions)
	% E-PASS (AVI) Transactions	% Cash Transactions	
2000	46.0%	54.0%	2.6%
2001	51.0%	49.0%	2.6%
2002	56.7%	43.3%	2.0%
2003	59.6%	40.4%	2.2%
2004	65.7%	34.3%	2.5%
2005	68.2%	31.8%	2.9%
2006	70.6%	29.4%	2.6%
2007	73.2%	26.8%	2.6%
2008	74.4%	25.6%	2.6%
2009	75.9%	24.1%	3.0%
2010	76.9%	23.1%	2.9%
2011	77.4%	22.6%	2.8%
2012	80.2%	19.8%	3.0%
2013	84.6%	15.4%	3.3%
2014	87.3%	12.7%	4.0%
2015	84.4%	15.6%	4.6%
2016	88.8%	11.2%	5.7%
2017	91.0%	9.0%	8.0%
2018	91.3%	8.7%	12.3%

1. In FY 18, all plazas had tolls suspended from September 5, 2017 to September 21, 2017 due to Hurricane Irma.
2. Calculated as percentage of Total Transactions, which is equal to Revenue Transactions plus Violations.



Independence Mainline Toll Facility (Western Beltway)



2018 Traffic Data and Statistics Manual
CENTRAL FLORIDA EXPRESSWAY AUTHORITY

OSCEOLA

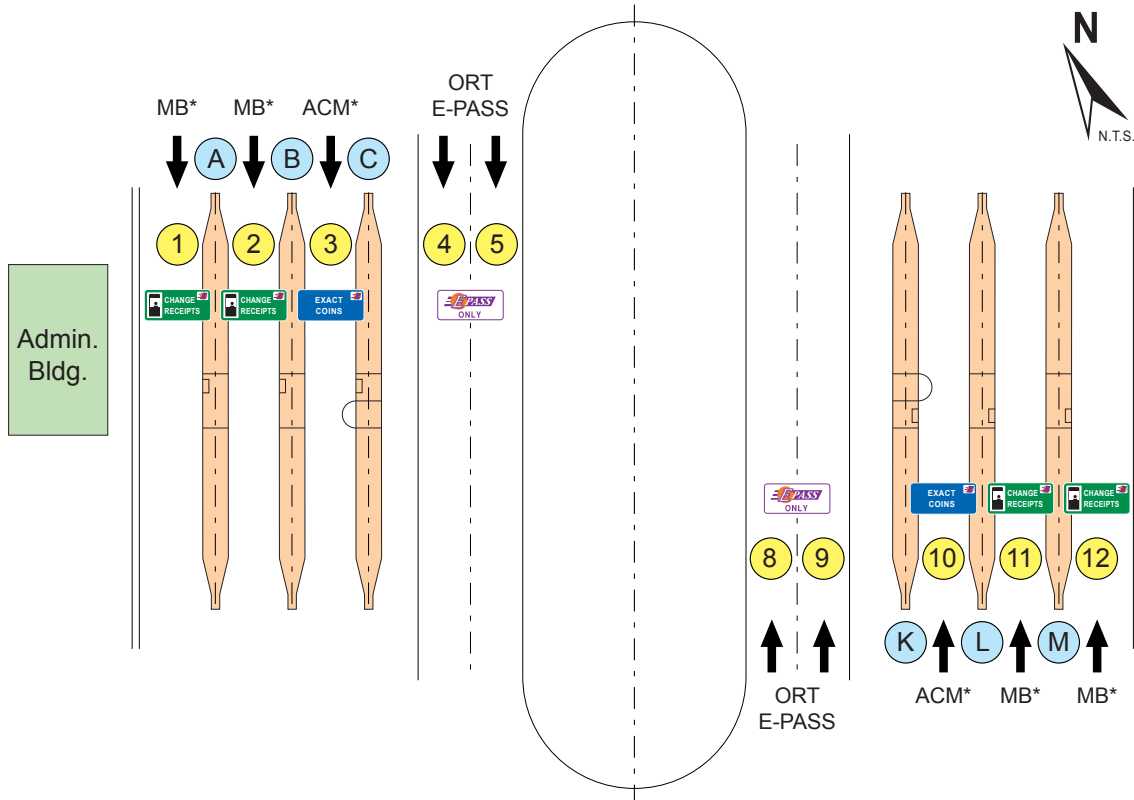

HISTORIC TRAFFIC - A.A.W.T.

2006	8,400	2011	14,130	2016	31,570
2007	14,000	2012	15,930 <i>(Toll Increase July 2012)</i>	2017	41,260
2008	13,500	2013	16,620	2018	49,150 <i>(Toll Increase July 2018)</i>
2009	12,500 <i>(Toll Increase April 2009)</i>	2014	19,520		
2010	13,700	2015	26,200		

TOLL RATE STRUCTURE

	<u>E-PASS</u>	<u>CASH</u>
2 Axles	\$ 1.43	\$ 1.75
3 Axles	\$ 1.99	\$ 2.25
4 Axles	\$ 2.57	\$ 3.00
5 Axles or more	\$ 3.13	\$ 3.50

(Toll Rates Effective July 1, 2019)

LANES OF EQUIPMENT

- 4 Manned Booths (MB) with E-PASS
- 2 Booths with Automatic Coin Machines (ACM) and E-PASS
- 4 Open Road Tolling (ORT) E-PASS
- * Changeable Message Sign

LEGEND

- ① Lane Number
- Ⓐ Island Designation



Approx. Scale: 1" = 200'
January 2018

Independence Mainline Toll Facility

SR 429 - Western Beltway

Fiscal Year 2018 Monthly Mainline & Ramp Toll Transactions and Revenue Summary

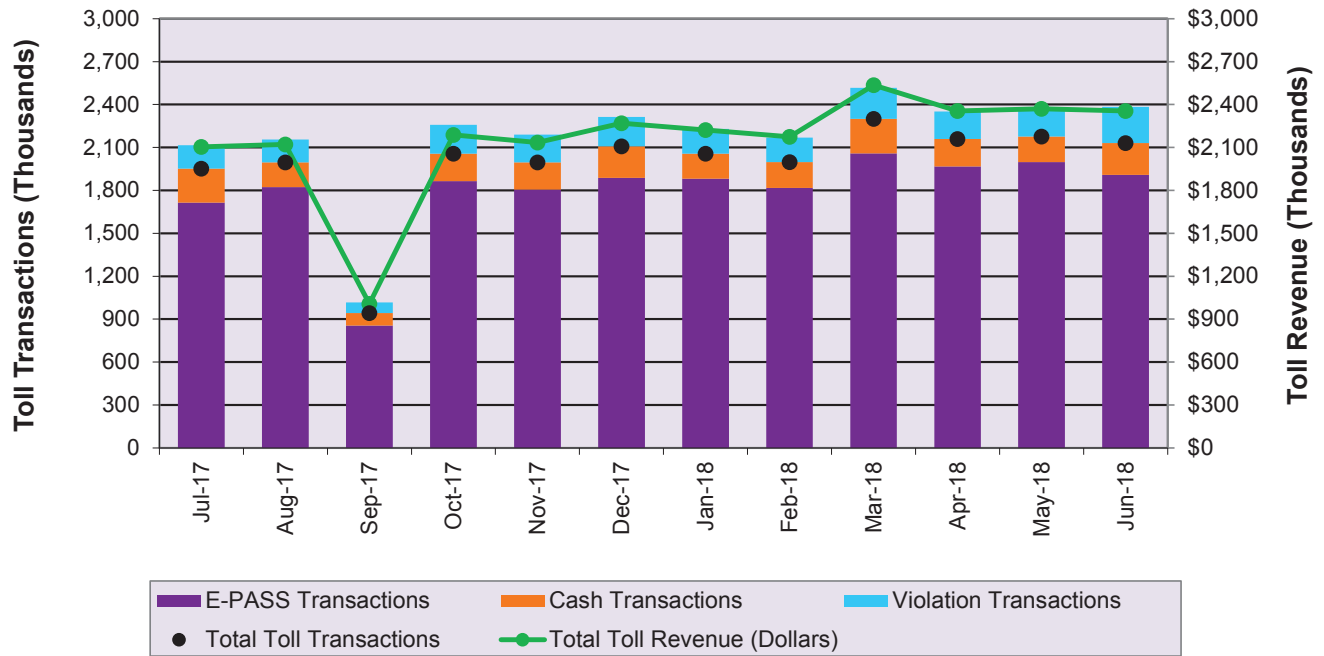

Month	FY 18 MONTHLY MAINLINE & RAMP TOLL TRANSACTIONS					Total Toll Revenue
	E-PASS	Cash	Total Revenue	Violations	Total	
July-17	1,714,999	237,775	1,952,774	162,947	2,115,721	\$2,103,484
August-17	1,823,437	171,764	1,995,201	161,010	2,156,211	\$2,120,780
September-17	854,764	88,558	943,322	74,027	1,017,349	\$1,006,704
October-17	1,864,927	191,449	2,056,376	202,157	2,258,533	\$2,186,802
November-17	1,805,422	190,650	1,996,072	194,241	2,190,313	\$2,135,075
December-17	1,887,598	219,468	2,107,066	206,166	2,313,232	\$2,269,885
January-18	1,881,065	175,238	2,056,303	173,393	2,229,696	\$2,222,275
February-18	1,817,244	179,657	1,996,901	171,657	2,168,558	\$2,174,962
March-18	2,058,976	240,360	2,299,336	216,380	2,515,716	\$2,535,703
April-18	1,966,986	191,543	2,158,529	192,232	2,350,761	\$2,354,734
May-18	1,998,311	178,020	2,176,331	197,723	2,374,054	\$2,369,660
June-18	1,908,082	222,156	2,130,238	253,822	2,384,060	\$2,355,134
Yearly Totals	21,581,811	2,286,638	23,868,449	2,205,755	26,074,204	\$25,835,198

Note: Data includes ramp toll plazas that report to the Independence Mainline Toll Plaza.

1. Cash transactions are calculated as the difference between total revenue traffic and E-PASS traffic.

2. In FY 18, all plazas had tolls suspended from September 5, 2017 to September 21, 2017 due to Hurricane Irma.



SR 429 (WESTERN BELTWAY) Independence Mainline Toll Facility

SECTION III

Independence Mainline Toll Facility SR 429 - Western Beltway Typical Daily Traffic Volumes - April 2018

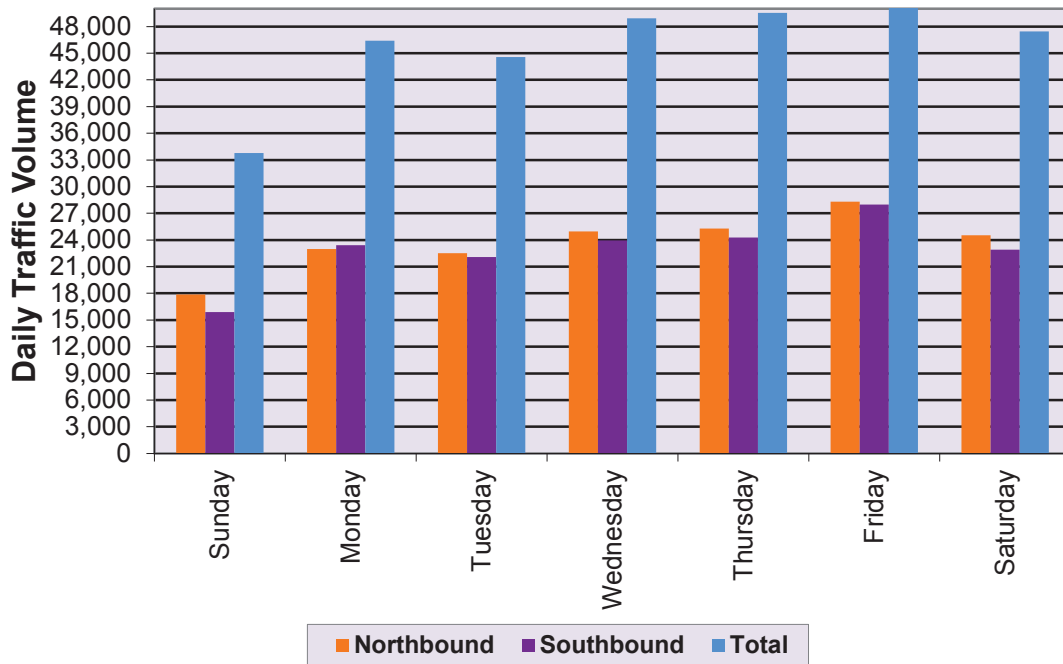

Day	Expressway Traffic Volumes		
	Northbound	Southbound	Total
Sunday	17,886	15,885	33,770
Monday	22,981	23,425	46,406
Tuesday	22,512	22,071	44,583
Wednesday	24,968	23,948	48,916
Thursday	25,275	24,276	49,551
Friday	28,289	27,995	56,284
Saturday	24,522	22,917	47,438

Independence Mainline Toll Facility

SR 429 - Western Beltway

Average Five Day Hourly Traffic - April 2018

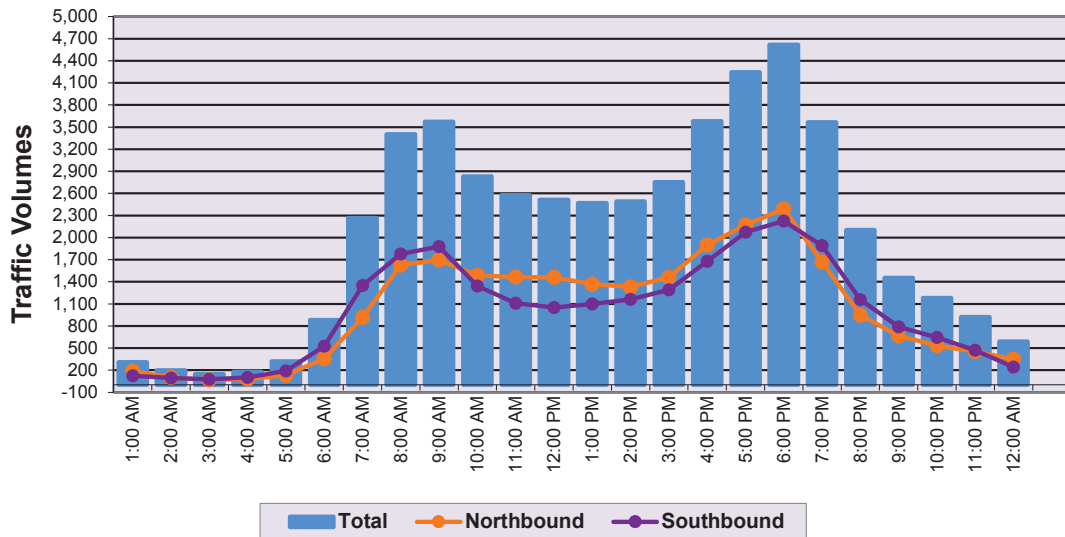

Hour Ending	Average Weekday Volumes		
	Northbound	Southbound	Total
1:00 AM	186	122	308
2:00 AM	102	95	197
3:00 AM	69	77	147
4:00 AM	77	102	179
5:00 AM	129	191	321
6:00 AM	357	525	882
7:00 AM	917	1,348	2,265
8:00 AM	1,625	1,779	3,404
9:00 AM	1,697	1,876	3,574
10:00 AM	1,487	1,342	2,829
11:00 AM	1,465	1,109	2,574
12:00 PM	1,460	1,051	2,511

Hour Ending	Average Weekday Volumes		
	Northbound	Southbound	Total
1:00 PM	1,367	1,100	2,467
2:00 PM	1,329	1,163	2,492
3:00 PM	1,460	1,292	2,752
4:00 PM	1,899	1,680	3,578
5:00 PM	2,170	2,073	4,243
6:00 PM	2,392	2,226	4,618
7:00 PM	1,671	1,892	3,563
8:00 PM	945	1,158	2,103
9:00 PM	667	787	1,454
10:00 PM	534	646	1,180
11:00 PM	452	469	920
12:00 AM	347	243	590

Total Northbound	24,805
Total Southbound	24,343
Total Weekday	49,148



SR 429 (WESTERN BELTWAY) Independence Mainline Toll Facility

SECTION III

Independence Mainline Toll Facility

SR 429 - Western Beltway

Average Seven Day Hourly Traffic - April 2018

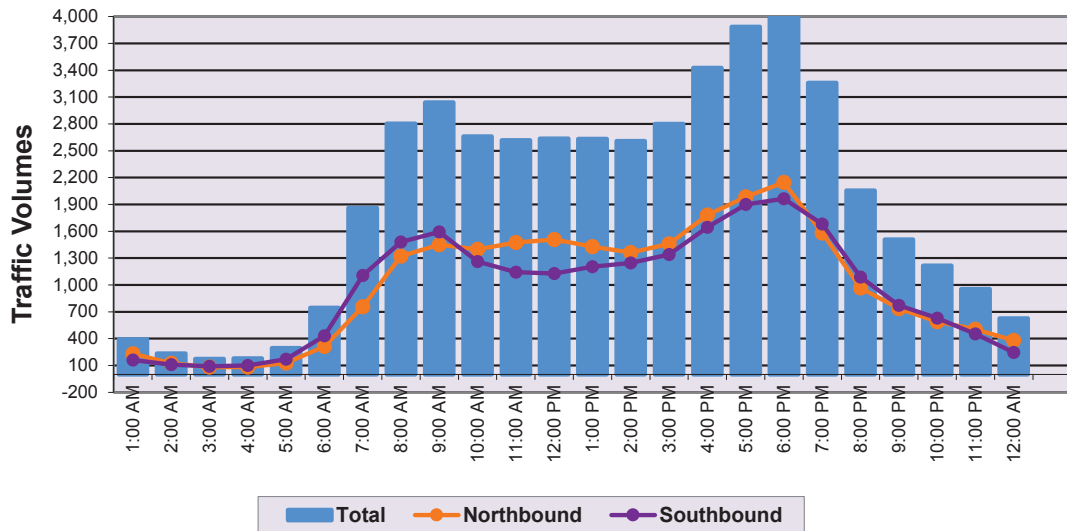

Hour Ending	Average Weekday Volumes		
	Northbound	Southbound	Total
1:00 AM	231	161	392
2:00 AM	123	110	233
3:00 AM	81	90	172
4:00 AM	81	99	180
5:00 AM	126	169	295
6:00 AM	313	432	744
7:00 AM	755	1,106	1,861
8:00 AM	1,322	1,479	2,802
9:00 AM	1,448	1,592	3,040
10:00 AM	1,399	1,260	2,658
11:00 AM	1,475	1,142	2,617
12:00 PM	1,508	1,128	2,636

Hour Ending	Average Weekday Volumes		
	Northbound	Southbound	Total
1:00 PM	1,428	1,203	2,631
2:00 PM	1,363	1,246	2,608
3:00 PM	1,460	1,339	2,799
4:00 PM	1,781	1,645	3,426
5:00 PM	1,986	1,901	3,886
6:00 PM	2,146	1,964	4,110
7:00 PM	1,580	1,680	3,260
8:00 PM	967	1,088	2,055
9:00 PM	735	773	1,507
10:00 PM	588	628	1,216
11:00 PM	503	451	954
12:00 AM	378	247	625

Total Northbound	23,776
Total Southbound	22,931
Total Weekday	46,707



SR 429 (WESTERN BELTWAY) Independence Mainline Toll Facility

SECTION III

Independence Mainline Toll Facility

Toll Facility Peak Hour Characteristic Summary

Typical Average Weekday (Monday through Friday) - April 2018

Average Weekday Traffic Summary (unadjusted)

Average Weekday Total Traffic	49,148
Northbound Directional Traffic	24,805
Southbound Directional Traffic	24,343

Morning Peak Hour Summary (7:00 a.m. to 8:00 a.m.)

Northbound Directional Traffic	1,697
Southbound Directional Traffic	1,876
Total AM Peak Hour Traffic	3,574

AM Peak Hour Factor ("K") = Total Peak Hour Traffic / Average Weekday Total Traffic

AM Peak Hour Factor ("K_{am}")	7.27%
---	--------------

AM Peak Hour Directional Factor ("D") = Peak Directional Traffic / Total Peak Hour Traffic

AM Peak Hour Directional Factor ("D_{am}")	52.51%
---	---------------

Evening Peak Hour Summary (5:00 p.m. to 6:00 p.m.)

Northbound Directional Traffic	2,392
Southbound Directional Traffic	2,226
Total PM Peak Hour Traffic	4,618

PM Peak Hour Factor ("K") = Total Peak Hour Traffic / Average Weekday Total Traffic

PM Peak Hour Factor ("K_{pm}")	9.40%
---	--------------

PM Peak Hour Directional Factor ("D") = Peak Directional Traffic / Total Peak Hour Traffic

PM Peak Hour Directional Factor ("D_{pm}")	51.80%
---	---------------



Independence Mainline Toll Facility

Toll Transaction Summary

Typical Average Weekday (Monday through Friday) - April 2018

Average Weekday Summary

Direction of Travel	E-PASS (AVI)		ACM (Coin)		Manual (Cash)		Total	
	Volume	% Usage	Volume	% Usage	Volume	% Usage	Traffic	% Usage
Northbound	22,080	89%	408	2%	2,207	9%	24,694	100%
Southbound	21,760	90%	381	2%	2,095	9%	24,237	100%

Morning Peak Hour Summary (7:00 a.m. to 8:00 a.m.)

Direction of Travel	E-PASS (AVI)		ACM (Coin)		Manual (Cash)		Total	
	Volume	% Usage	Volume	% Usage	Volume	% Usage	Traffic	% Usage
Northbound	1,556	92%	18	1%	114	7%	1,688	100%
Southbound	1,755	94%	13	1%	103	6%	1,871	100%

Evening Peak Hour Summary (5:00 p.m. to 6:00 p.m.)

Direction of Travel	E-PASS (AVI)		ACM (Coin)		Manual (Cash)		Total	
	Volume	% Usage	Volume	% Usage	Volume	% Usage	Traffic	% Usage
Northbound	2,168	91%	38	2%	179	7%	2,385	100%
Southbound	1,994	90%	41	2%	182	8%	2,217	100%



Independence Mainline Toll Facility

SR 429 - Western Beltway

Historical & Existing Total Revenue Transactions Statistics

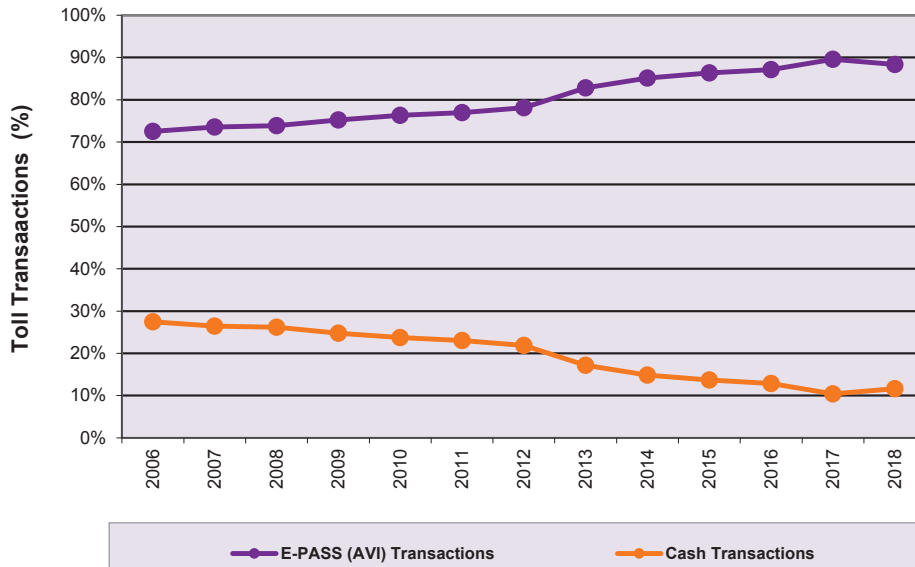

Year	Yearly Revenue Transaction		% Violations ⁽²⁾ (Percent of Total Transactions)
	% E-PASS (AVI) Transactions	% Cash Transactions	
2000	Not Open to Traffic		
2001	Not Open to Traffic		
2002	Not Open to Traffic		
2003	Not Open to Traffic		
2004	Not Open to Traffic		
2005	Not Open to Traffic		
2006	72.5%	27.5%	2.2%
2007	73.5%	26.5%	2.1%
2008	73.8%	26.2%	2.1%
2009	75.2%	24.8%	2.5%
2010	76.3%	23.7%	2.3%
2011	76.9%	23.1%	2.2%
2012	78.1%	21.9%	2.5%
2013	82.8%	17.2%	3.0%
2014	85.1%	14.9%	3.7%
2015	86.3%	13.7%	4.4%
2016	87.1%	12.9%	5.2%
2017	89.6%	10.4%	7.5%
2018	88.4%	11.6%	11.7%

1. In FY 18, all plazas had tolls suspended from September 5, 2017 to September 21, 2017 due to Hurricane Irma.

2. Calculated as percentage of Total Transactions, which is equal to Revenue Transactions plus Violations.



Forest Lake Mainline Toll Facility (Western Beltway)



2018 Traffic Data and Statistics Manual
CENTRAL FLORIDA EXPRESSWAY AUTHORITY

OSCEOLA

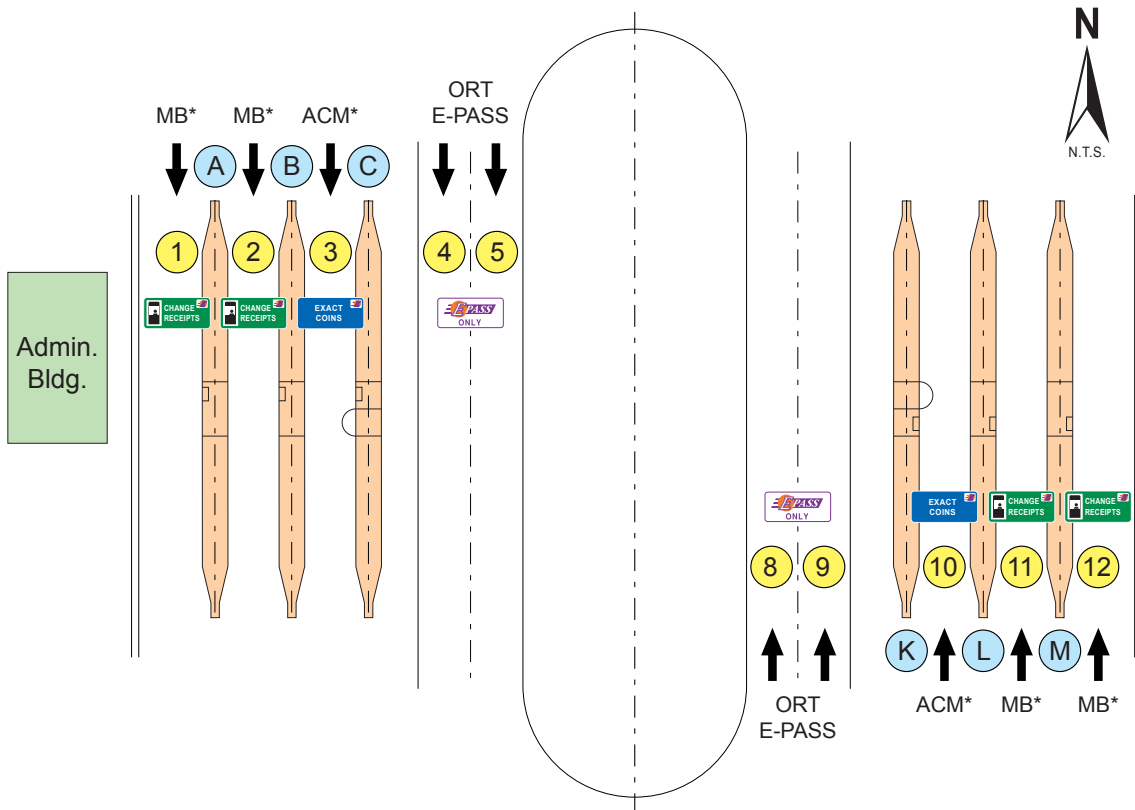

HISTORIC TRAFFIC - A.A.W.T.

2000	8,360	2007	30,410	2014	38,930
2001	13,620	2008	27,000	2015	46,360
2002	16,940	2009	27,600 <i>(Toll Increase April 2009)</i>	2016	53,510
2003	20,140	2010	29,500	2017	61,000
2004	23,820	2011	29,600	2018	66,700 <i>(Toll Increase July 2018)</i>
2005	27,900	2012	31,650 <i>(Toll Increase July 2012)</i>		
2006	29,200	2013	34,430		

TOLL RATE STRUCTURE

	<u>E-PASS</u>	<u>CASH</u>
2 Axles	\$ 1.43	\$ 1.75
3 Axles	\$ 1.99	\$ 2.25
4 Axles	\$ 2.57	\$ 3.00
5 Axles or more	\$ 3.13	\$ 3.50

(Toll Rates Effective July 1, 2019)

LANES OF EQUIPMENT

- 4 Manned Booths (MB) with E-PASS
- 2 Booths with Automatic Coin Machines (ACM) and E-PASS
- 4 Open Road Tolling (ORT) E-PASS
- * Changeable Message Sign

LEGEND

- ① Lane Number
- Ⓐ Island Designation



Approx. Scale: 1" = 200'
January 2018

Forest Lake Mainline Toll Facility
SR 429 - Western Beltway and Wekiva Parkway
Fiscal Year 2018 Monthly Mainline & Ramp Toll Transactions and Revenue Summary

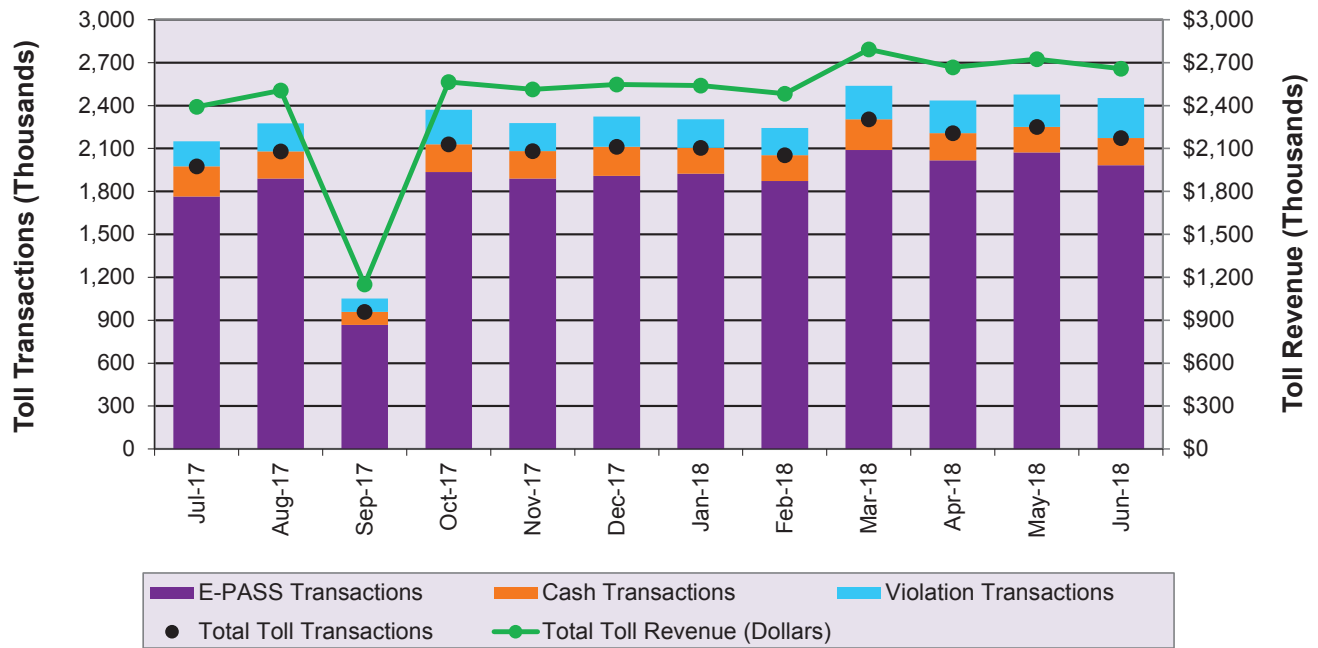

Month	FY 18 MONTHLY MAINLINE & RAMP TOLL TRANSACTIONS					Total Toll Revenue
	E-PASS	Cash	Total Revenue	Violations	Total	
July-17	1,763,815	211,962	1,975,777	174,030	2,149,807	\$2,391,730
August-17	1,889,862	189,347	2,079,209	196,796	2,276,005	\$2,506,013
September-17	867,096	91,073	958,169	93,732	1,051,901	\$1,150,608
October-17	1,935,915	194,356	2,130,271	241,507	2,371,778	\$2,565,012
November-17	1,888,993	192,745	2,081,738	195,734	2,277,472	\$2,514,204
December-17	1,908,351	204,449	2,112,800	209,605	2,322,405	\$2,548,047
January-18	1,923,492	181,019	2,104,511	198,953	2,303,464	\$2,539,173
February-18	1,872,038	180,599	2,052,637	190,537	2,243,174	\$2,483,071
March-18	2,089,954	214,790	2,304,744	233,019	2,537,763	\$2,792,840
April-18	2,016,919	189,929	2,206,848	227,910	2,434,758	\$2,667,332
May-18	2,072,642	178,842	2,251,484	225,952	2,477,436	\$2,725,324
June-18	1,983,972	188,826	2,172,798	280,552	2,453,350	\$2,657,279
Yearly Totals	22,213,049	2,217,937	24,430,986	2,468,327	26,899,313	\$29,540,633

Note: Data includes ramp toll plazas that report to the Forest Lake Mainline Toll Plaza.

1. Cash transactions are calculated as the difference between total revenue traffic and E-PASS traffic.
2. In FY 18, all plazas had tolls suspended from September 5, 2017 to September 21, 2017 due to Hurricane Irma.



Forest Lake Mainline Toll Facility
SR 429 - Western Beltway and Wekiva Parkway
 Typical Daily Traffic Volumes - April 2018

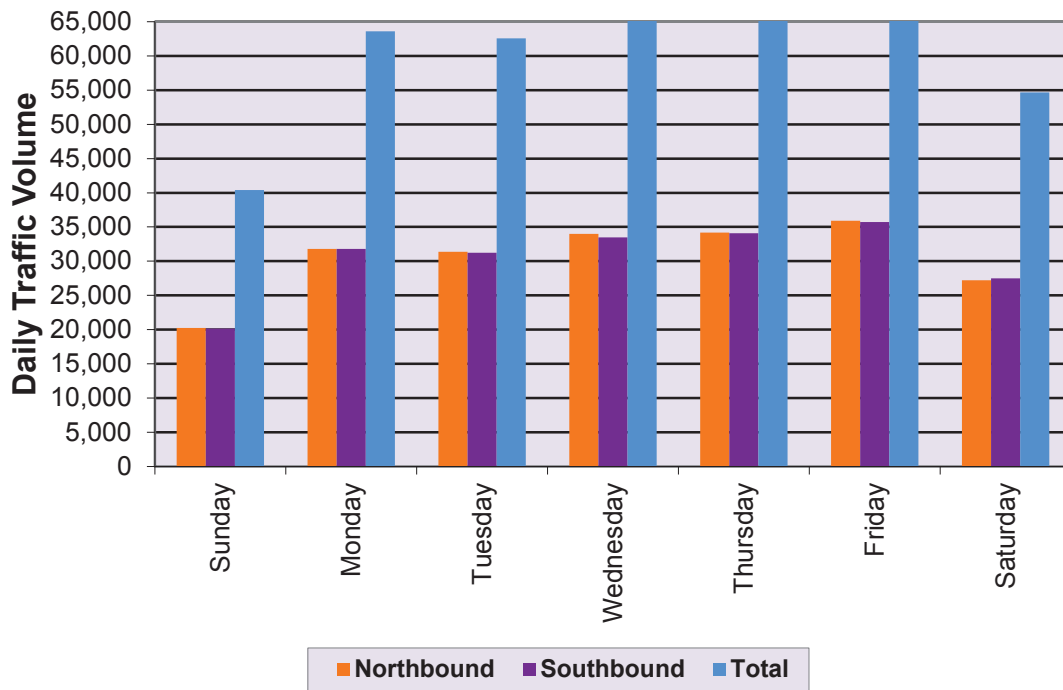

Day	Expressway Traffic Volumes		
	Northbound	Southbound	Total
Sunday	20,256	20,165	40,421
Monday	31,811	31,793	63,604
Tuesday	31,378	31,213	62,591
Wednesday	33,975	33,456	67,430
Thursday	34,194	34,079	68,273
Friday	35,896	35,710	71,606
Saturday	27,199	27,468	54,667



Forest Lake Mainline Toll Facility
SR 429 - Western Beltway and Wekiva Parkway
 Average Five Day Hourly Traffic - April 2018

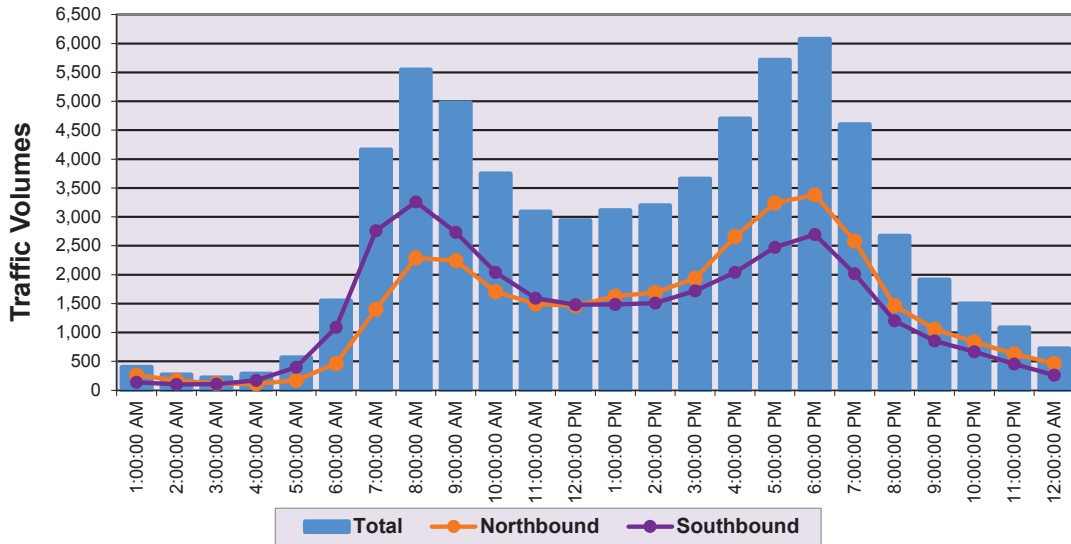

Hour Ending	Average Weekday Volumes		
	Northbound	Southbound	Total
1:00 AM	262	140	402
2:00 AM	172	101	273
3:00 AM	115	106	220
4:00 AM	112	173	285
5:00 AM	172	396	568
6:00 AM	463	1,088	1,552
7:00 AM	1,402	2,760	4,162
8:00 AM	2,288	3,257	5,545
9:00 AM	2,241	2,734	4,975
10:00 AM	1,705	2,042	3,746
11:00 AM	1,496	1,595	3,091
12:00 PM	1,462	1,478	2,939

Hour Ending	Average Weekday Volumes		
	Northbound	Southbound	Total
1:00 PM	1,628	1,485	3,112
2:00 PM	1,691	1,509	3,199
3:00 PM	1,936	1,722	3,659
4:00 PM	2,656	2,042	4,698
5:00 PM	3,242	2,474	5,716
6:00 PM	3,380	2,696	6,076
7:00 PM	2,580	2,018	4,598
8:00 PM	1,466	1,203	2,669
9:00 PM	1,055	856	1,911
10:00 PM	833	665	1,498
11:00 PM	630	452	1,083
12:00 AM	465	260	724

Total Northbound	33,451
Total Southbound	33,250
Total Weekday	66,701



SR 429 (WESTERN BELTWAY)
Forest Lake Mainline Toll Facility

Forest Lake Mainline Toll Facility
SR 429 - Western Beltway and Wekiva Parkway
Average Seven Day Hourly Traffic - April 2018

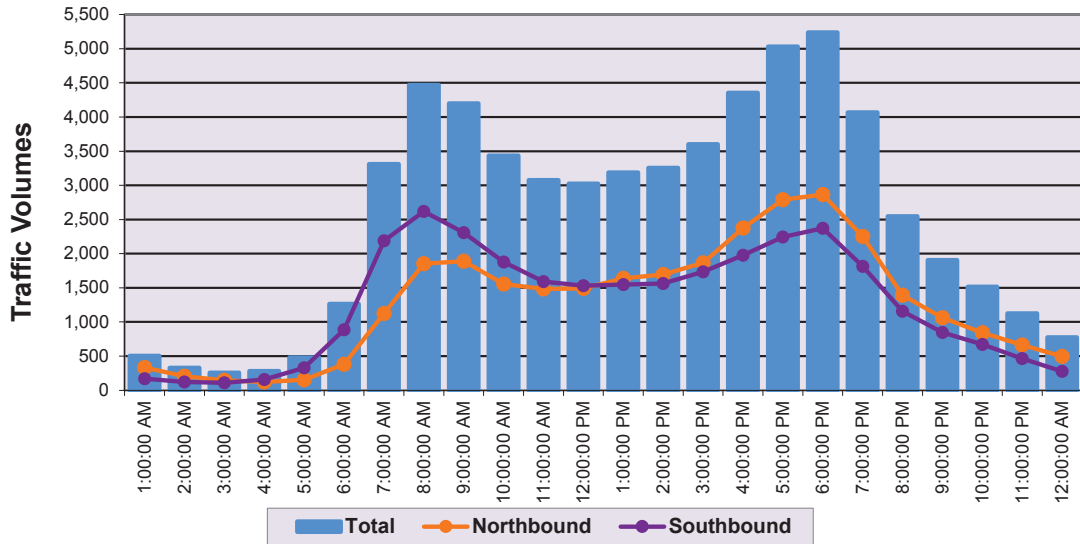

Hour Ending	Average Weekday Volumes		
	Northbound	Southbound	Total
1:00 AM	334	170	503
2:00 AM	207	120	327
3:00 AM	145	111	255
4:00 AM	123	157	280
5:00 AM	152	329	481
6:00 AM	380	884	1,264
7:00 AM	1,123	2,188	3,311
8:00 AM	1,853	2,618	4,472
9:00 AM	1,890	2,308	4,198
10:00 AM	1,556	1,879	3,436
11:00 AM	1,483	1,592	3,075
12:00 PM	1,492	1,533	3,025

Hour Ending	Average Weekday Volumes		
	Northbound	Southbound	Total
1:00 PM	1,641	1,546	3,187
2:00 PM	1,694	1,563	3,257
3:00 PM	1,865	1,736	3,600
4:00 PM	2,375	1,978	4,353
5:00 PM	2,787	2,243	5,031
6:00 PM	2,865	2,373	5,238
7:00 PM	2,253	1,816	4,068
8:00 PM	1,391	1,157	2,548
9:00 PM	1,060	846	1,907
10:00 PM	843	670	1,514
11:00 PM	664	463	1,127
12:00 AM	498	276	773

Total Northbound	30,673
Total Southbound	30,555
Total Weekday	61,227



SR 429 (WESTERN BELTWAY)
Forest Lake Mainline Toll Facility

Forest Lake Mainline Toll Facility

Toll Facility Peak Hour Characteristic Summary Typical Average Weekday (Monday through Friday) - April 2018

Average Weekday Traffic Summary (unadjusted)

Average Weekday Total Traffic	66,701
Northbound Directional Traffic	33,451
Southbound Directional Traffic	33,250

Morning Peak Hour Summary (7:00 a.m. to 8:00 a.m.)

Northbound Directional Traffic	2,288
Southbound Directional Traffic	3,257
Total AM Peak Hour Traffic	5,545

AM Peak Hour Factor ("K") = Total Peak Hour Traffic / Average Weekday Total Traffic

AM Peak Hour Factor ("K_{am}") 8.31%

AM Peak Hour Directional Factor ("D") = Peak Directional Traffic / Total Peak Hour Traffic

AM Peak Hour Directional Factor ("D_{am}") 58.73%

Evening Peak Hour Summary (5:00 p.m. to 6:00 p.m.)

Northbound Directional Traffic	3,380
Southbound Directional Traffic	2,696
Total PM Peak Hour Traffic	6,076

PM Peak Hour Factor ("K") = Total Peak Hour Traffic / Average Weekday Total Traffic

PM Peak Hour Factor ("K_{pm}") 9.11%

PM Peak Hour Directional Factor ("D") = Peak Directional Traffic / Total Peak Hour Traffic

PM Peak Hour Directional Factor ("D_{pm}") 55.63%

Forest Lake Mainline Toll Facility

Toll Transaction Summary

Typical Average Weekday (Monday through Friday) - April 2018

Average Weekday Summary

Direction of Travel	E-PASS (AVI)		ACM (Coin)		Manual (Cash)		Total	
	Volume	% Usage	Volume	% Usage	Volume	% Usage	Traffic	% Usage
Northbound	30,909	93%	0	0%	2,295	7%	33,204	100%
Southbound	30,699	93%	0	0%	2,308	7%	33,006	100%

Morning Peak Hour Summary (7:00 a.m. to 8:00 a.m.)

Direction of Travel	E-PASS (AVI)		ACM (Coin)		Manual (Cash)		Total	
	Volume	% Usage	Volume	% Usage	Volume	% Usage	Traffic	% Usage
Northbound	2,184	96%	0	0%	92	4%	2,276	100%
Southbound	3,096	96%	0	0%	134	4%	3,230	100%

Evening Peak Hour Summary (5:00 p.m. to 6:00 p.m.)

Direction of Travel	E-PASS (AVI)		ACM (Coin)		Manual (Cash)		Total	
	Volume	% Usage	Volume	% Usage	Volume	% Usage	Traffic	% Usage
Northbound	3,155	94%	0	0%	204	6%	3,358	100%
Southbound	2,495	93%	0	0%	184	7%	2,679	100%

Forest Lake Mainline Toll Facility
SR 429 - Western Beltway and Wekiva Parkway
Historical & Existing Total Revenue Transactions Statistics

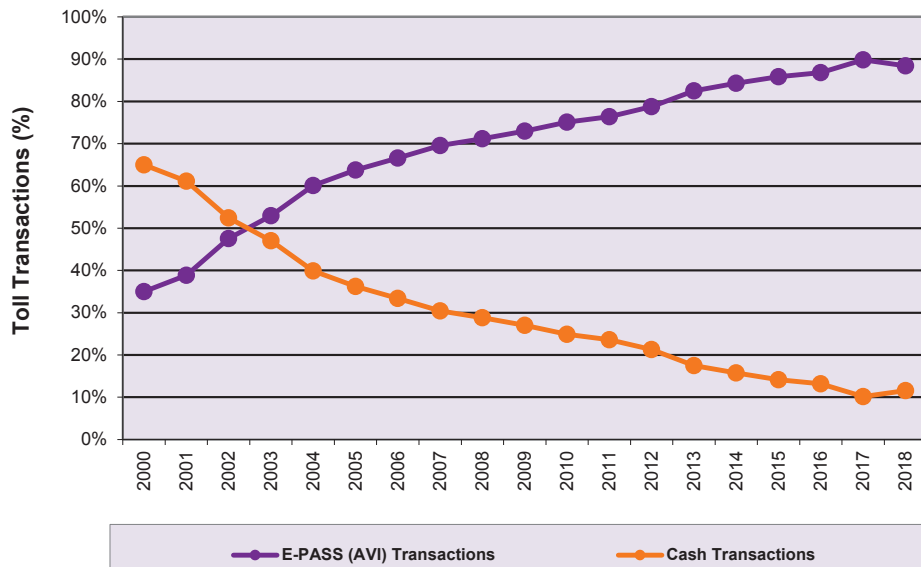

Year	Yearly Revenue Transaction		% Violations ⁽²⁾ (Percent of Total Transactions)
	% E-PASS (AVI) Transactions	% Cash Transactions	
2000	35.0%	65.0%	4.8%
2001	38.8%	61.2%	3.8%
2002	47.5%	52.5%	2.7%
2003	53.0%	47.0%	2.4%
2004	60.1%	39.9%	2.7%
2005	63.8%	36.2%	3.1%
2006	66.6%	33.4%	3.0%
2007	69.6%	30.4%	2.6%
2008	71.2%	28.8%	2.6%
2009	73.0%	27.0%	2.8%
2010	75.1%	24.9%	2.7%
2011	76.4%	23.6%	2.3%
2012	78.7%	21.3%	2.5%
2013	82.5%	17.5%	3.0%
2014	84.3%	15.7%	3.7%
2015	85.8%	14.2%	4.6%
2016	86.8%	13.2%	5.3%
2017	89.8%	10.2%	6.6%
2018	88.4%	11.6%	12.1%

1. In FY 18, all plazas had tolls suspended from September 5, 2017 to September 21, 2017 due to Hurricane Irma.

2. Calculated as percentage of Total Transactions, which is equal to Revenue Transactions plus Violations.



Coral Hills Mainline Toll Facility (Apopka Expressway)



2018 Traffic Data and Statistics Manual
CENTRAL FLORIDA EXPRESSWAY AUTHORITY

OSCEOLA

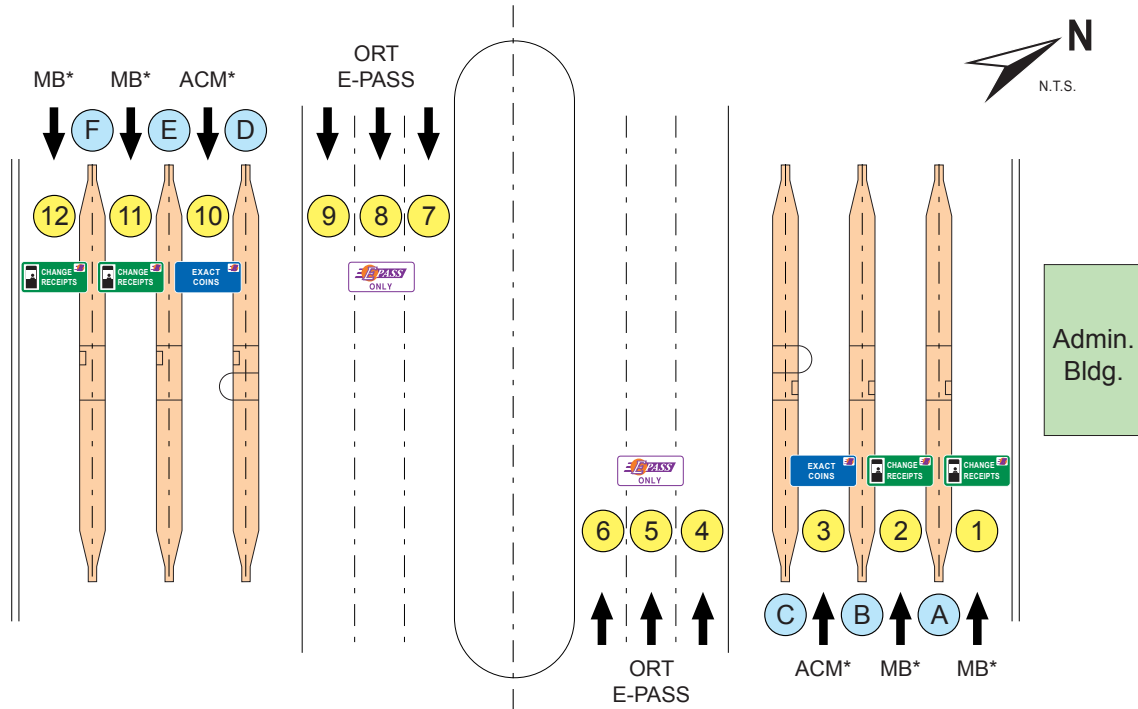

HISTORIC TRAFFIC - A.A.W.T.

2009	10,500	2013	20,870	2017	36,930
2010	13,025	2014	24,120	2018	41,570 (Toll Increase July 2018)
2011	13,820	2015	29,100		
2012	16,320 (Toll Increase July 2012)	2016	33,900		

TOLL RATE STRUCTURE

	<u>E-PASS</u>	<u>CASH</u>
2 Axles	\$ 1.13	\$ 1.25
3 Axles	\$ 1.71	\$ 2.00
4 Axles	\$ 2.27	\$ 2.50
5 Axles or more	\$ 3.13	\$ 3.25

(Toll Rates Effective July 1, 2019)

LANES OF EQUIPMENT

- 4 Manned Booths (MB) with E-PASS
- 2 Booths with Automatic Coin Machines (ACM) and E-PASS
- 6 Open Road Tolling (ORT) E-PASS
- * Changeable Message Sign

LEGEND

- ① Lane Number
- Ⓐ Island Designation



Approx. Scale: 1" = 200'
January 2018

Coral Hills Mainline Toll Facility

SR 414 - Apopka Expressway

Fiscal Year 2018 Monthly Mainline & Ramp Toll Transactions and Revenue Summary

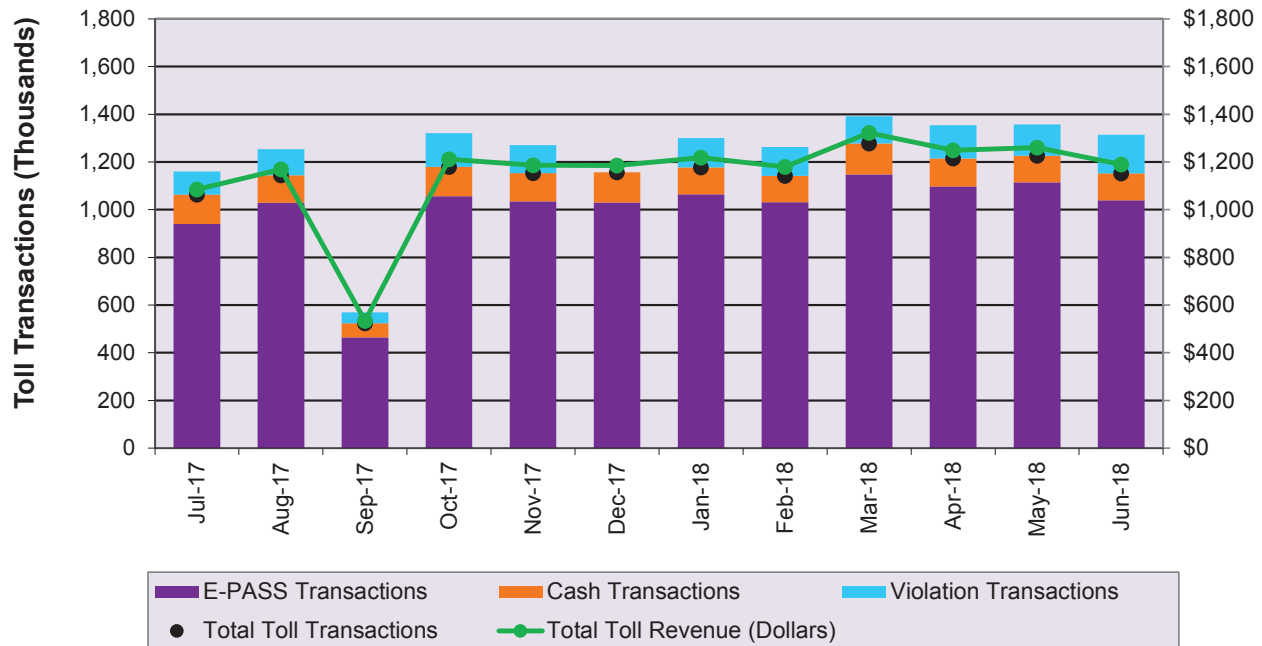

Month	FY 18 MONTHLY MAINLINE & RAMP TOLL TRANSACTIONS					Total Toll Revenue
	E-PASS	Cash	Total Revenue	Violations	Total	
July-17	940,326	123,078	1,063,404	97,233	1,160,637	\$1,085,163
August-17	1,029,020	115,479	1,144,499	108,794	1,253,293	\$1,168,817
September-17	464,869	58,398	523,267	45,648	568,915	\$534,114
October-17	1,056,090	123,259	1,179,349	141,314	1,320,663	\$1,211,270
November-17	1,034,645	118,412	1,153,057	117,560	1,270,617	\$1,186,694
December-17	1,030,695	125,594	1,156,289	124,010	1,280,299	\$1,185,455
January-18	1,064,797	112,105	1,176,902	120,783	1,297,685	\$1,218,045
February-18	1,031,614	110,396	1,142,010	114,223	1,256,233	\$1,179,431
March-18	1,147,137	130,908	1,278,045	139,432	1,417,477	\$1,322,315
April-18	1,097,542	117,172	1,214,714	131,351	1,346,065	\$1,249,173
May-18	1,114,294	111,967	1,226,261	132,767	1,359,028	\$1,260,348
June-18	1,039,416	112,757	1,152,173	161,986	1,314,159	\$1,189,684
Yearly Totals	12,050,445	1,359,525	13,409,970	1,435,101	14,845,071	\$13,790,509

Note: Data includes ramp toll plazas that report to the Coral Hills Mainline Toll Plaza.

1. Cash transactions are calculated as the difference between total revenue traffic and E-PASS traffic.

2. In FY 18, all plazas had tolls suspended from September 5, 2017 to September 21, 2017 due to Hurricane Irma.



Coral Hills Mainline Toll Facility
SR 414 - Apopka Expressway
Typical Daily Expressway Traffic Volumes - April 2018

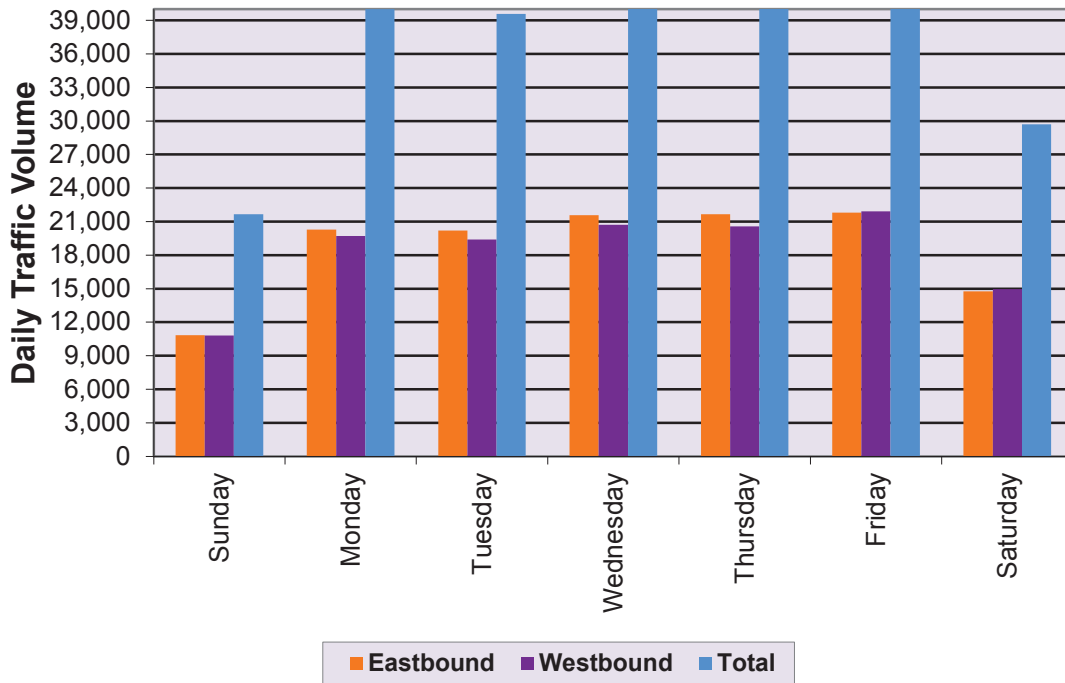

Day	Expressway Traffic Volumes		
	Eastbound	Westbound	Total
Sunday	10,847	10,823	21,669
Monday	20,273	19,723	39,995
Tuesday	20,185	19,406	39,590
Wednesday	21,564	20,723	42,287
Thursday	21,667	20,583	42,250
Friday	21,806	21,909	43,715
Saturday	14,755	14,947	29,702

Coral Hills Mainline Toll Facility
SR 414 - Apopka Expressway
 Typical Average Five Day Hourly Traffic - April 2018

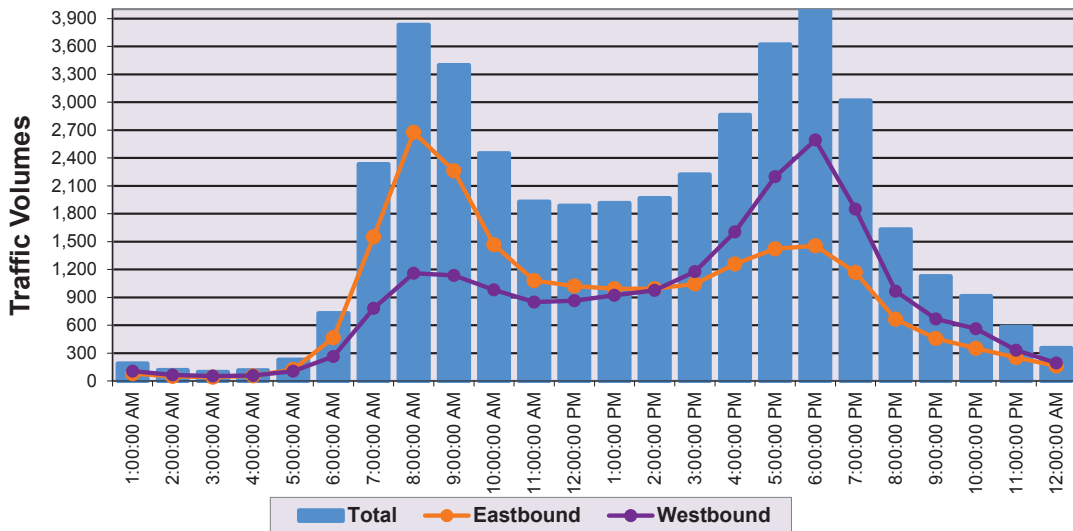

Hour Ending	Average Weekday Volumes		
	Eastbound	Westbound	Total
1:00 AM	81	107	188
2:00 AM	52	66	118
3:00 AM	41	55	96
4:00 AM	57	58	115
5:00 AM	124	105	229
6:00 AM	466	263	729
7:00 AM	1,551	783	2,334
8:00 AM	2,674	1,159	3,833
9:00 AM	2,263	1,135	3,398
10:00 AM	1,466	983	2,449
11:00 AM	1,080	849	1,929
12:00 PM	1,023	864	1,886

Hour Ending	Average Weekday Volumes		
	Eastbound	Westbound	Total
1:00 PM	992	923	1,915
2:00 PM	992	975	1,967
3:00 PM	1,044	1,177	2,221
4:00 PM	1,260	1,603	2,864
5:00 PM	1,422	2,197	3,619
6:00 PM	1,456	2,594	4,050
7:00 PM	1,167	1,850	3,018
8:00 PM	666	965	1,631
9:00 PM	458	669	1,127
10:00 PM	351	561	912
11:00 PM	251	333	584
12:00 AM	161	195	356

Total Eastbound	21,099
Total Westbound	20,468
Total Weekday	41,567



SR 414 (APOPKA EXPRESSWAY)
Coral Hills Mainline Toll Facility

Coral Hills Mainline Toll Facility
SR 414 - Apopka Expressway
Typical Average Seven Day Hourly Traffic - April 2018

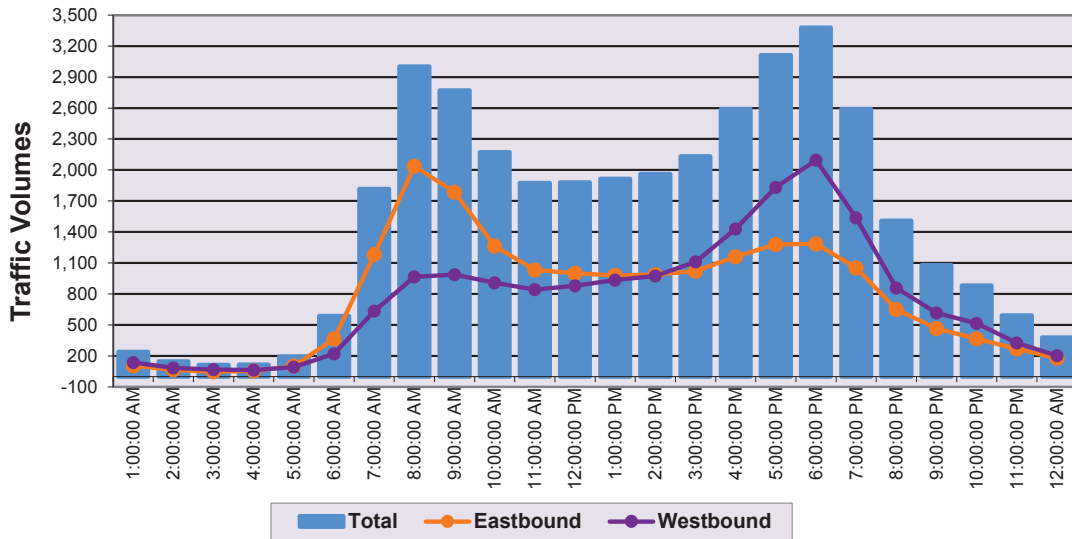

Hour Ending	Average Weekday Volumes		
	Eastbound	Westbound	Total
1:00 AM	104	136	239
2:00 AM	64	83	147
3:00 AM	47	67	113
4:00 AM	55	61	116
5:00 AM	102	91	193
6:00 AM	366	221	587
7:00 AM	1,182	634	1,816
8:00 AM	2,038	965	3,003
9:00 AM	1,785	986	2,771
10:00 AM	1,264	908	2,172
11:00 AM	1,031	842	1,873
12:00 PM	1,000	880	1,880

Hour Ending	Average Weekday Volumes		
	Eastbound	Westbound	Total
1:00 PM	979	935	1,914
2:00 PM	987	974	1,961
3:00 PM	1,022	1,112	2,134
4:00 PM	1,162	1,428	2,590
5:00 PM	1,280	1,831	3,112
6:00 PM	1,284	2,095	3,379
7:00 PM	1,053	1,538	2,592
8:00 PM	650	857	1,507
9:00 PM	465	615	1,080
10:00 PM	365	516	881
11:00 PM	267	325	593
12:00 AM	177	201	379

Total Eastbound	18,728
Total Westbound	18,302
Total Weekday	37,029



SR 414 (APOPKA EXPRESSWAY)
Coral Hills Mainline Toll Facility

Coral Hills Mainline Toll Facility

Toll Facility Peak Hour Characteristic Summary Typical Average Weekday (Monday through Friday) - April 2018

Average Weekday Traffic Summary (unadjusted)

Average Weekday Total Traffic	41,567
Eastbound Directional Traffic	21,099
Westbound Directional Traffic	20,468

Morning Peak Hour Summary (7:00 a.m. to 8:00 a.m.)

Eastbound Directional Traffic	2,674
Westbound Directional Traffic	1,159
Total AM Peak Hour Traffic	3,833

AM Peak Hour Factor ("K") = Total Peak Hour Traffic / Average Weekday Total Traffic

AM Peak Hour Factor ("K_{am}") **9.22%**

AM Peak Hour Directional Factor ("D") = Peak Directional Traffic / Total Peak Hour Traffic

AM Peak Hour Directional Factor ("D_{am}") **69.77%**

Evening Peak Hour Summary (5:00 p.m. to 6:00 p.m.)

Eastbound Directional Traffic	1,456
Westbound Directional Traffic	2,594
Total PM Peak Hour Traffic	4,050

PM Peak Hour Factor ("K") = Total Peak Hour Traffic / Average Weekday Total Traffic

PM Peak Hour Factor ("K_{pm}") **9.74%**

PM Peak Hour Directional Factor ("D") = Peak Directional Traffic / Total Peak Hour Traffic

PM Peak Hour Directional Factor ("D_{pm}") **64.04%**



Coral Hills Mainline Toll Facility

Toll Transaction Summary

Typical Average Weekday (Monday through Friday) - April 2018

Average Weekday Summary

Direction of Travel	E-PASS (AVI)		ACM (Coin)		Manual (Cash)		Total	
	Volume	% Usage	Volume	% Usage	Volume	% Usage	Traffic	% Usage
Eastbound	19,582	93%	0	0%	1,383	7%	20,965	100%
Westbound	18,976	93%	0	0%	1,366	7%	20,341	100%

Morning Peak Hour Summary (7:00 a.m. to 8:00 a.m.)

Direction of Travel	E-PASS (AVI)		ACM (Coin)		Manual (Cash)		Total	
	Volume	% Usage	Volume	% Usage	Volume	% Usage	Traffic	% Usage
Eastbound	2,570	97%	0	0%	89	3%	2,660	100%
Westbound	1,099	95%	0	0%	54	5%	1,153	100%

Evening Peak Hour Summary (5:00 p.m. to 6:00 p.m.)

Direction of Travel	E-PASS (AVI)		ACM (Coin)		Manual (Cash)		Total	
	Volume	% Usage	Volume	% Usage	Volume	% Usage	Traffic	% Usage
Eastbound	1,352	93%	0	0%	98	7%	1,450	100%
Westbound	2,440	95%	0	0%	139	5%	2,578	100%

Coral Hills Mainline Toll Facility
SR 414 - Apopka Expressway
Historical & Existing Total Revenue Transactions Statistics

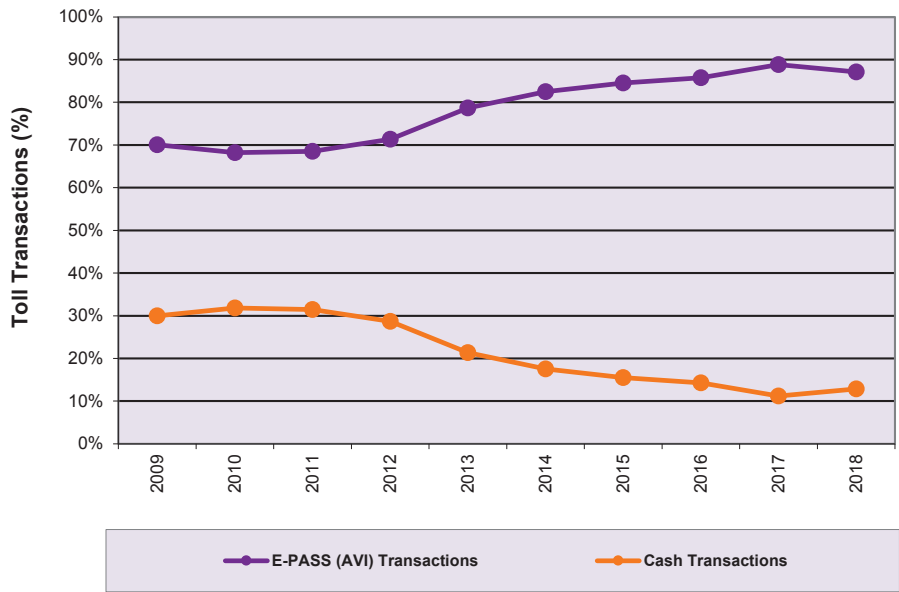

Year	Yearly Revenue Transaction		% Violations ⁽²⁾ (Percent of Total Transactions)
	% E-PASS (AVI) Transactions	% Cash Transactions	
2000	Not Open to Traffic		
2001	Not Open to Traffic		
2002	Not Open to Traffic		
2003	Not Open to Traffic		
2004	Not Open to Traffic		
2005	Not Open to Traffic		
2006	Not Open to Traffic		
2007	Not Open to Traffic		
2008	Not Open to Traffic		
2009	70.1%	29.9%	2.9%
2010	68.2%	31.8%	2.5%
2011	68.5%	31.5%	2.7%
2012	71.3%	28.7%	2.9%
2013	78.6%	21.4%	3.4%
2014	82.5%	17.5%	4.2%
2015	84.5%	15.5%	5.0%
2016	85.7%	14.3%	5.8%
2017	88.8%	11.2%	8.4%
2018	87.1%	12.9%	12.0%

1. In FY 18, all plazas had tolls suspended from September 5, 2017 to September 21, 2017 due to Hurricane Irma.
2. Calculated as percentage of Total Transactions, which is equal to Revenue Transactions plus Violations.



Ponkan Toll Gantry Facility (Wekiva Parkway)



2018 Traffic Data and Statistics Manual
CENTRAL FLORIDA EXPRESSWAY AUTHORITY

OSCEOLA

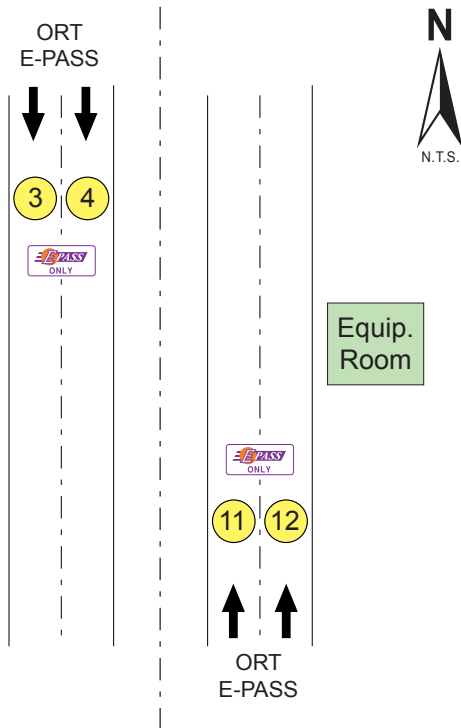

HISTORIC TRAFFIC - A.A.W.T.

2017	9,560*
2018	14,630 (Toll Increase July 2018)

TOLL RATE STRUCTURE

	<u>E-PASS</u>	<u>PAY-BY-PLATE</u>
2 Axles	\$.82	\$ 1.41
3 Axles	\$ 1.23	\$ 1.82
4 Axles	\$ 1.64	\$ 2.23
5 Axles or more	\$ 1.92	\$ 2.63

(Toll Rates Effective July 1, 2019)

* Opened to traffic July 28, 2017.

LANES OF EQUIPMENT

- 4 Open Road Tolling (ORT) E-PASS and Pay-by-Plate (PBP)

LEGEND

- ① Lane Number





Approx. Scale: 1" = 200'
January 2018

Ponkan Toll Gantry SR 429 - Wekiva Parkway

Fiscal Year 2018 Monthly Mainline & Ramp Toll Transactions and Revenue Summary

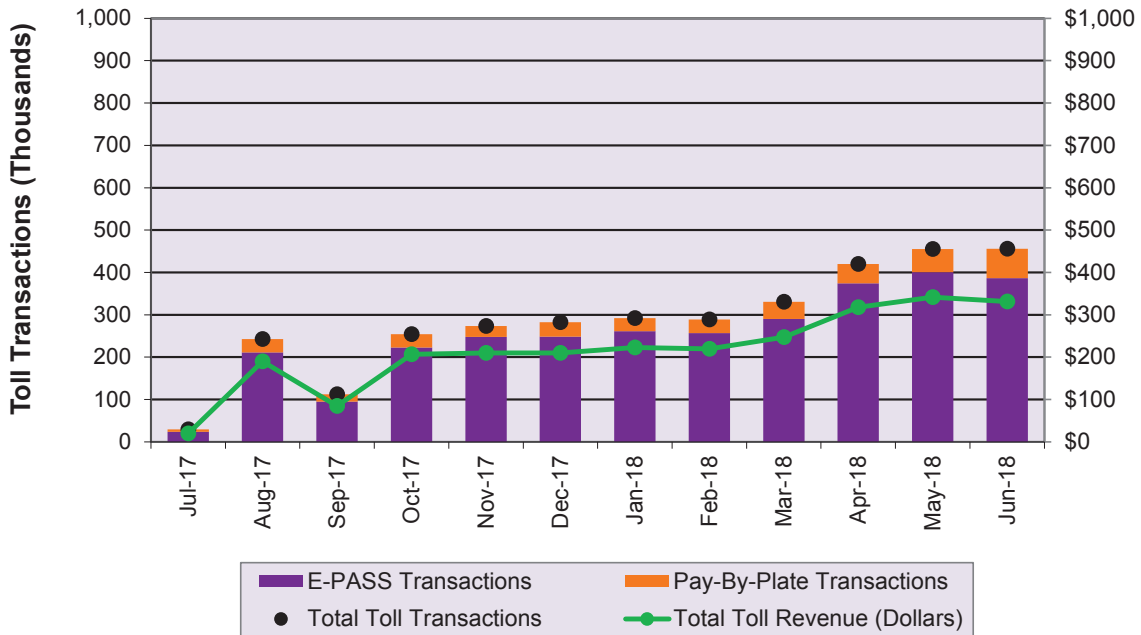

Month	FY 18 MONTHLY MAINLINE & RAMP TOLL TRANSACTIONS			Total Toll Revenue
	E-PASS	Pay-By-Plate	Total	
July-17	23,571	5,888	29,459	\$19,649
August-17	210,925	31,661	242,586	\$189,728
September-17	94,975	17,118	112,093	\$84,359
October-17	222,756	31,125	253,881	\$206,756
November-17	247,711	25,504	273,215	\$209,825
December-17	248,083	34,174	282,257	\$210,154
January-18	260,958	31,177	292,135	\$223,022
February-18	256,567	32,408	288,975	\$219,568
March-18	290,041	40,652	330,693	\$246,807
April-18	374,492	45,540	420,032	\$318,024
May-18	400,742	54,771	455,513	\$341,321
June-18	386,707	69,359	456,066	\$331,005
Yearly Totals	3,017,528	419,377	3,436,905	\$2,600,218

Note:

1. Pay-By-Plate transactions are calculated as the difference between total revenue traffic and E-PASS traffic.
2. Ponkan Toll Gantry opened to traffic on July 28, 2017.



SR 429 (WEKIVA PARKWAY) Ponkan Toll Gantry

SECTION III

Ponkan Toll Gantry

SR 429 - Wekiva Parkway

Typical Daily Expressway Traffic Volumes - April 2018

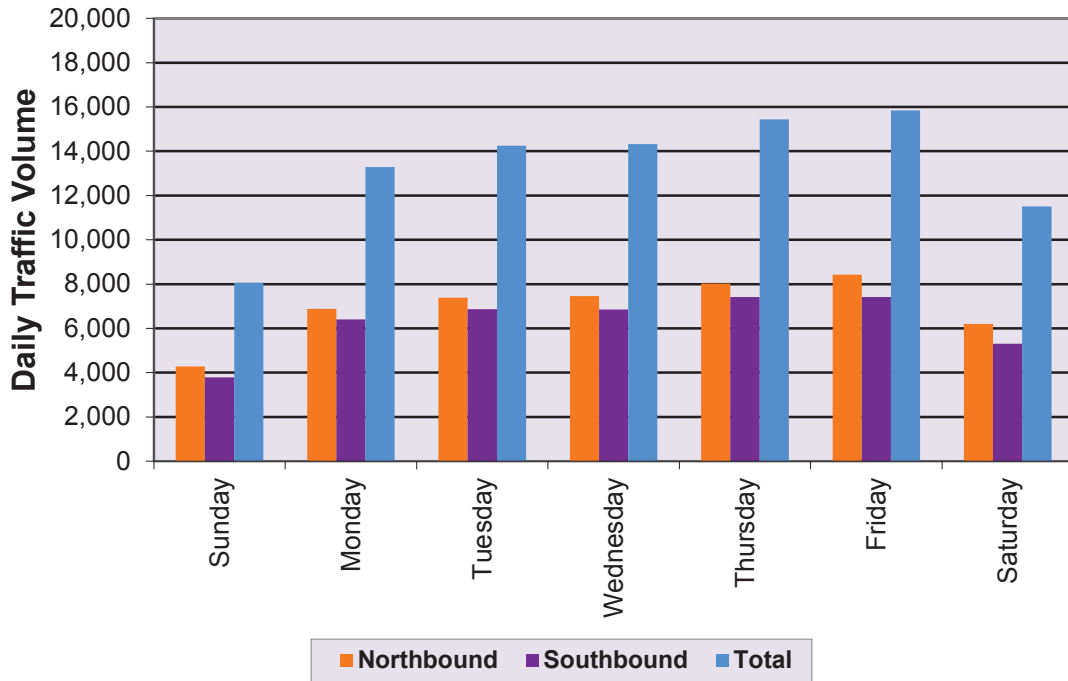

Day	Expressway Traffic Volumes		
	Northbound	Southbound	Total
Sunday	4,272	3,790	8,062
Monday	6,887	6,398	13,285
Tuesday	7,390	6,867	14,257
Wednesday	7,466	6,859	14,325
Thursday	8,027	7,412	15,439
Friday	8,428	7,413	15,841
Saturday	6,196	5,312	11,508

Ponkan Toll Gantry

SR 429 - Wekiva Parkway

Typical Average Five Day Hourly Traffic - April 2018

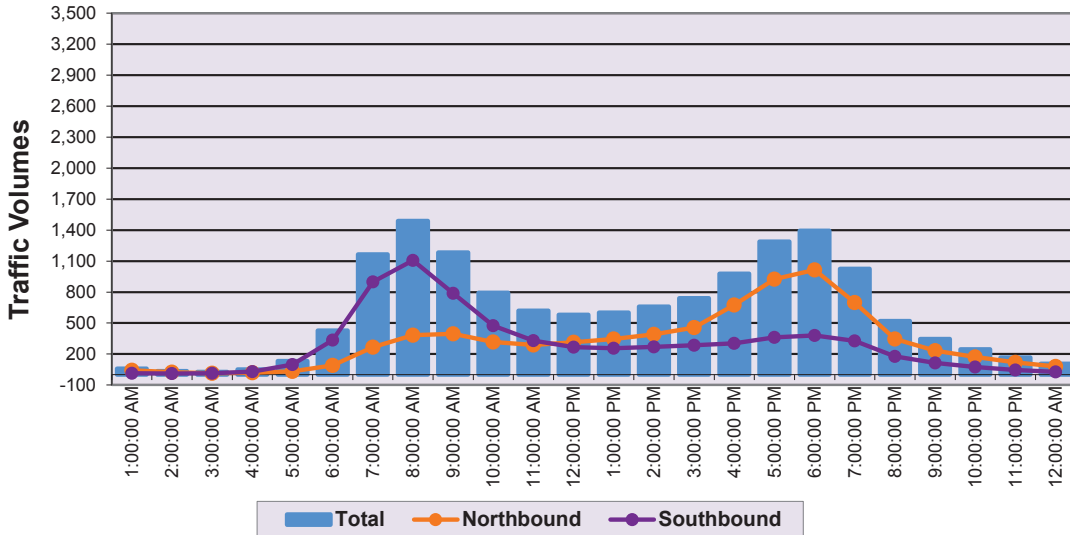

Hour Ending	Average Weekday Volumes		
	Northbound	Southbound	Total
1:00 AM	43	15	58
2:00 AM	24	10	34
3:00 AM	14	13	27
4:00 AM	20	31	50
5:00 AM	33	99	132
6:00 AM	91	336	427
7:00 AM	266	899	1,165
8:00 AM	383	1,107	1,490
9:00 AM	395	788	1,183
10:00 AM	317	476	793
11:00 AM	288	331	619
12:00 PM	315	266	581

Hour Ending	Average Weekday Volumes		
	Northbound	Southbound	Total
1:00 PM	346	255	601
2:00 PM	389	270	659
3:00 PM	456	285	741
4:00 PM	675	303	978
5:00 PM	926	362	1,288
6:00 PM	1,014	381	1,395
7:00 PM	698	327	1,025
8:00 PM	345	176	521
9:00 PM	232	114	346
10:00 PM	172	74	246
11:00 PM	119	47	165
12:00 AM	79	27	106

Total Northbound	7,640
Total Southbound	6,990
Total Weekday	14,629



SR 429 (WEKIVA PARKWAY) Ponkan Toll Gantry

SECTION III

Ponkan Toll Gantry
SR 429 - Wekiva Parkway
 Typical Average Seven Day Hourly Traffic - April 2018

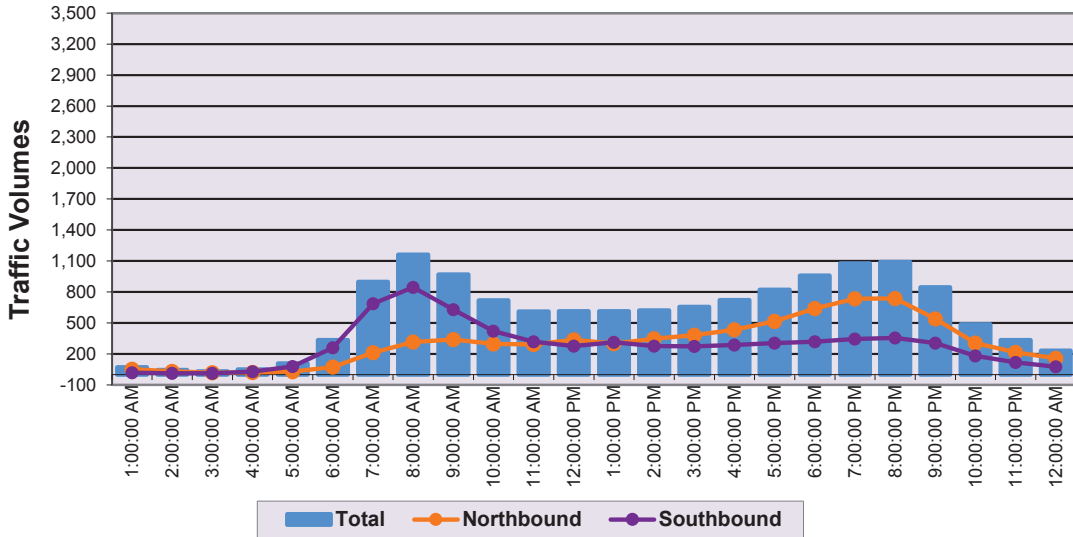

Hour Ending	Average Weekday Volumes		
	Northbound	Southbound	Total
1:00 AM	53	17	70
2:00 AM	31	13	43
3:00 AM	17	13	30
4:00 AM	21	27	48
5:00 AM	29	78	107
6:00 AM	74	261	335
7:00 AM	212	686	898
8:00 AM	316	844	1,160
9:00 AM	340	629	968
10:00 AM	296	421	717
11:00 AM	292	319	612
12:00 PM	337	276	613

Hour Ending	Average Weekday Volumes		
	Northbound	Southbound	Total
1:00 PM	301	312	613
2:00 PM	346	275	621
3:00 PM	381	273	655
4:00 PM	434	287	721
5:00 PM	515	306	820
6:00 PM	640	317	957
7:00 PM	733	344	1,077
8:00 PM	736	354	1,090
9:00 PM	538	305	844
10:00 PM	305	182	487
11:00 PM	215	119	334
12:00 AM	157	74	232

Total Northbound	7,318
Total Southbound	6,732
Total Weekday	14,050



SR 429 (WEKIVA PARKWAY)
Ponkan Toll Gantry

Ponkan Toll Gantry

Toll Facility Peak Hour Characteristic Summary Typical Average Weekday (Monday through Friday) - April 2018

Average Weekday Traffic Summary (unadjusted)

Average Weekday Total Traffic	14,629
Northbound Directional Traffic	7,640
Southbound Directional Traffic	6,990

Morning Peak Hour Summary (7:00 a.m. to 8:00 a.m.)

Northbound Directional Traffic	383
Southbound Directional Traffic	1,107
Total AM Peak Hour Traffic	1,490

AM Peak Hour Factor ("K") = Total Peak Hour Traffic / Average Weekday Total Traffic

AM Peak Hour Factor ("K_{am}") **10.18%**

AM Peak Hour Directional Factor ("D") = Peak Directional Traffic / Total Peak Hour Traffic

AM Peak Hour Directional Factor ("D_{am}") **74.29%**

Evening Peak Hour Summary (5:00 p.m. to 6:00 p.m.)

Northbound Directional Traffic	1,014
Southbound Directional Traffic	381
Total PM Peak Hour Traffic	1,395

PM Peak Hour Factor ("K") = Total Peak Hour Traffic / Average Weekday Total Traffic

PM Peak Hour Factor ("K_{pm}") **9.54%**

PM Peak Hour Directional Factor ("D") = Peak Directional Traffic / Total Peak Hour Traffic

PM Peak Hour Directional Factor ("D_{pm}") **72.72%**

Ponkan Toll Gantry

Toll Transaction Summary

Typical Average Weekday (Monday through Friday) - April 2018

Average Weekday Summary

Direction of Travel	E-PASS (AVI)		Pay-By-Plate		Total	
	Volume	% Usage	Volume	% Usage	Traffic	% Usage
Northbound	6,304	83%	1,335	17%	7,640	100%
Southbound	5,654	81%	1,335	19%	6,990	100%

Morning Peak Hour Summary (7:00 a.m. to 8:00 a.m.)

Direction of Travel	E-PASS (AVI)		Pay-By-Plate		Total	
	Volume	% Usage	Volume	% Usage	Traffic	% Usage
Northbound	212	55%	171	45%	383	100%
Southbound	936	85%	171	15%	1,107	100%

Evening Peak Hour Summary (5:00 p.m. to 6:00 p.m.)

Direction of Travel	E-PASS (AVI)		Pay-By-Plate		Total	
	Volume	% Usage	Volume	% Usage	Traffic	% Usage
Northbound	929	92%	85	8%	1,014	100%
Southbound	296	78%	85	22%	381	100%

Ponkan Toll Gantry
SR 429 - Wekiva Parkway
Historical & Existing Toll Transactions Statistics

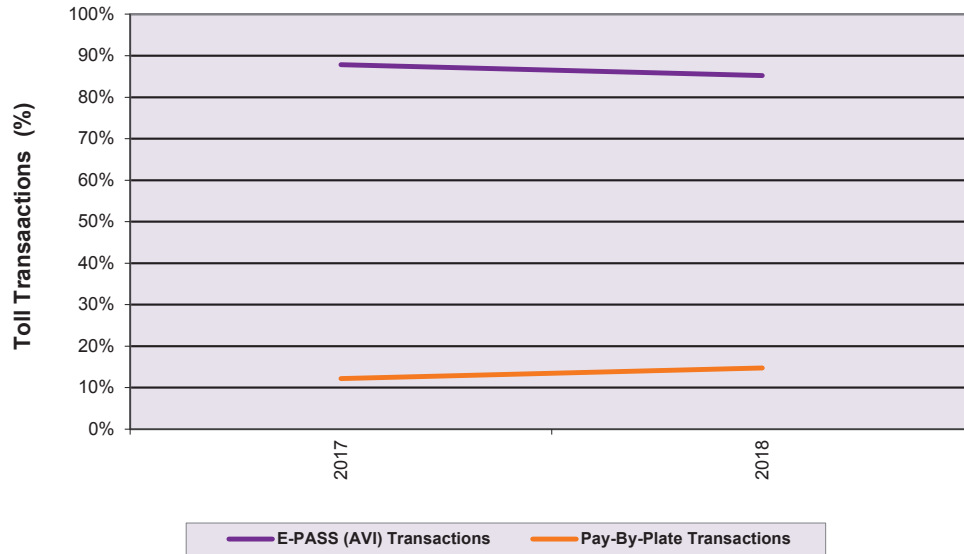

Year	Yearly Historical Toll Transaction Statistics	
	E-PASS (AVI) Transactions	Pay-By-Plate Transactions
2017	87.8%	12.2%
2018	85.2%	14.8%

1. In FY 18, all plazas had tolls suspended from September 5, 2017 to September 21, 2017 due to Hurricane Irma.
2. Ponkan Toll Gantry opened to traffic on July 28, 2017.

Mt. Plymouth Toll Gantry Facility (Wekiva Parkway)



2018 Traffic Data and Statistics Manual
CENTRAL FLORIDA EXPRESSWAY AUTHORITY

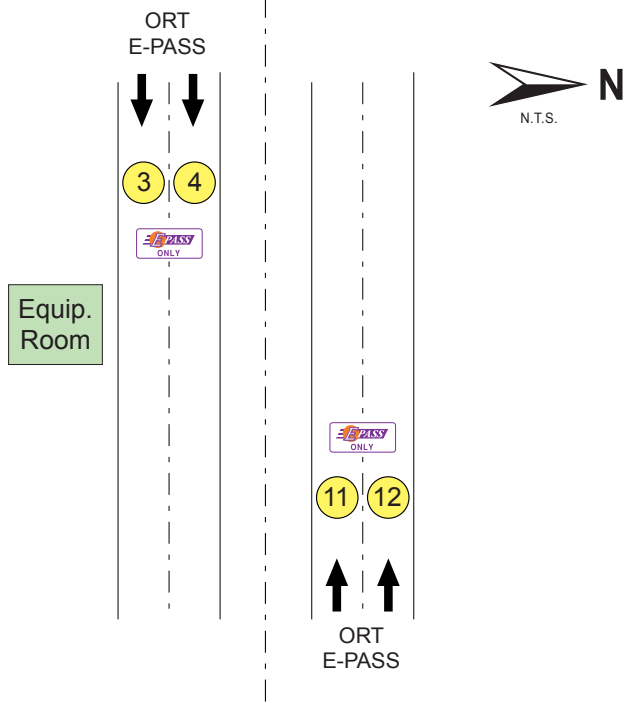

HISTORIC TRAFFIC - A.A.W.T.

2018 5,270* (Toll Increase July 2018)

TOLL RATE STRUCTURE

	<u>E-PASS</u>	<u>PAY-BY-PLATE</u>
2 Axles	\$.77	\$ 1.36
3 Axles	\$ 1.16	\$ 1.75
4 Axles	\$ 1.53	\$ 2.12
5 Axles or more	\$ 1.92	\$ 2.51

(Toll Rates Effective July 1, 2019)

LANES OF EQUIPMENT

- 4 Open Road Tolling (ORT) E-PASS and Pay-by-Plate (PBP)

LEGEND

- ① Lane Number

* Opened to traffic April 1, 2018





Not to Scale
Google Earth
February 2019

Mt. Plymouth Toll Gantry SR 429 - Wekiva Parkway

Fiscal Year 2018 Monthly Mainline & Ramp Toll Transactions and Revenue Summary

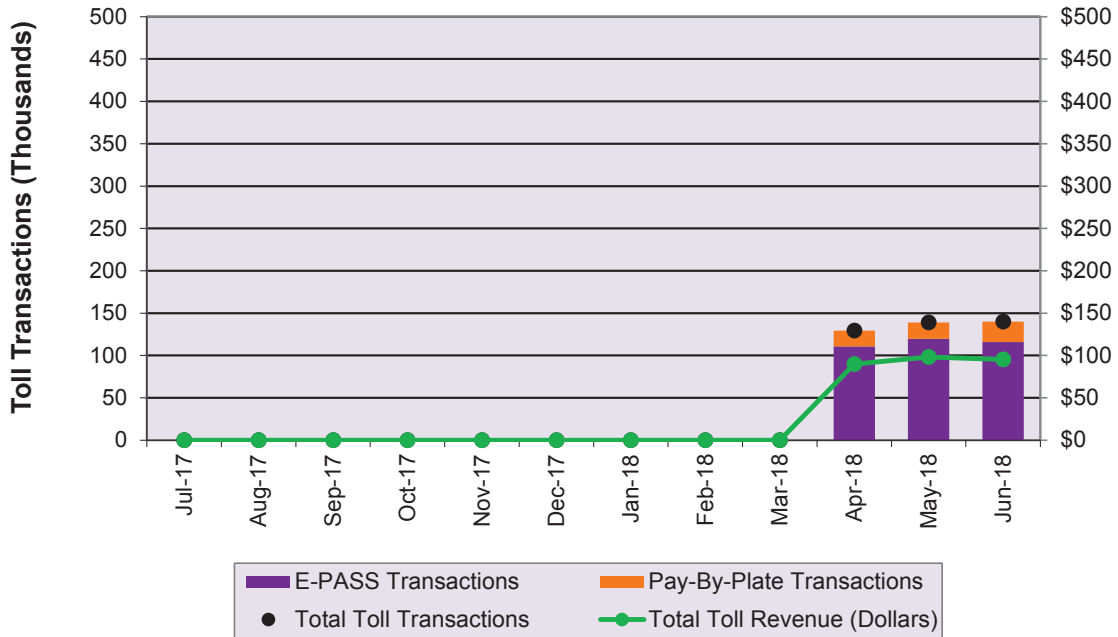

Month	FY 18 MONTHLY MAINLINE & RAMP TOLL TRANSACTIONS			Total Toll Revenue
	E-PASS	Pay-By-Plate	Total	
July-17	No Data	No Data	No Data	No Data
August-17	No Data	No Data	No Data	No Data
September-17	No Data	No Data	No Data	No Data
October-17	No Data	No Data	No Data	No Data
November-17	No Data	No Data	No Data	No Data
December-17	No Data	No Data	No Data	No Data
January-18	No Data	No Data	No Data	No Data
February-18	No Data	No Data	No Data	No Data
March-18	No Data	No Data	No Data	No Data
April-18	110,576	18,856	129,432	\$89,815
May-18	119,816	19,257	139,073	\$98,256
June-18	115,903	23,979	139,882	\$95,378
Yearly Totals	346,295	62,092	408,387	\$283,449

Note: Data includes ramp toll plazas that report to the Mount Plymouth Mainline Gantry

1. Pay-By-Plate transactions are calculated as the difference between total revenue traffic and E-PASS traffic.
2. Mt. Plymouth Toll Gantry opened to traffic on April 1, 2018.



Mt. Plymouth Toll Gantry

SR 429 - Wekiva Parkway

Typical Daily Expressway Traffic Volumes - April 2018

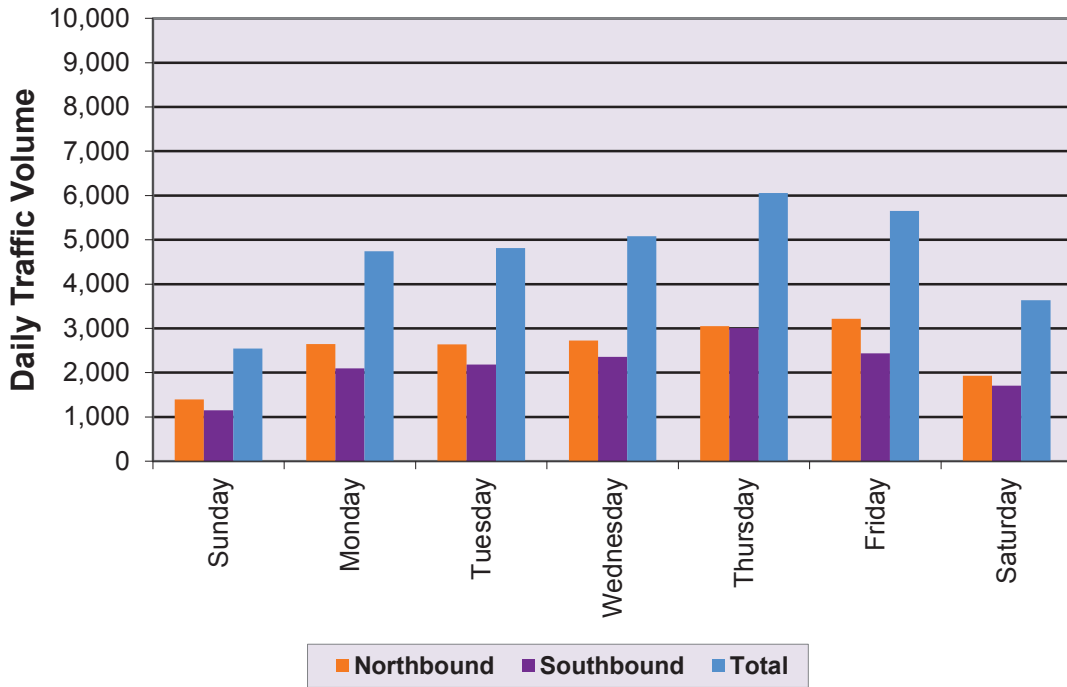

Day	Expressway Traffic Volumes		
	Eastbound	Westbound	Total
Sunday	1,394	1,152	2,546
Monday	2,643	2,096	4,739
Tuesday	2,637	2,180	4,817
Wednesday	2,725	2,358	5,083
Thursday	3,049	3,006	6,055
Friday	3,217	2,438	5,655
Saturday	1,929	1,706	3,635

Mt. Plymouth Toll Gantry SR 429 - Wekiva Parkway Typical Average Five Day Hourly Traffic - April 2018

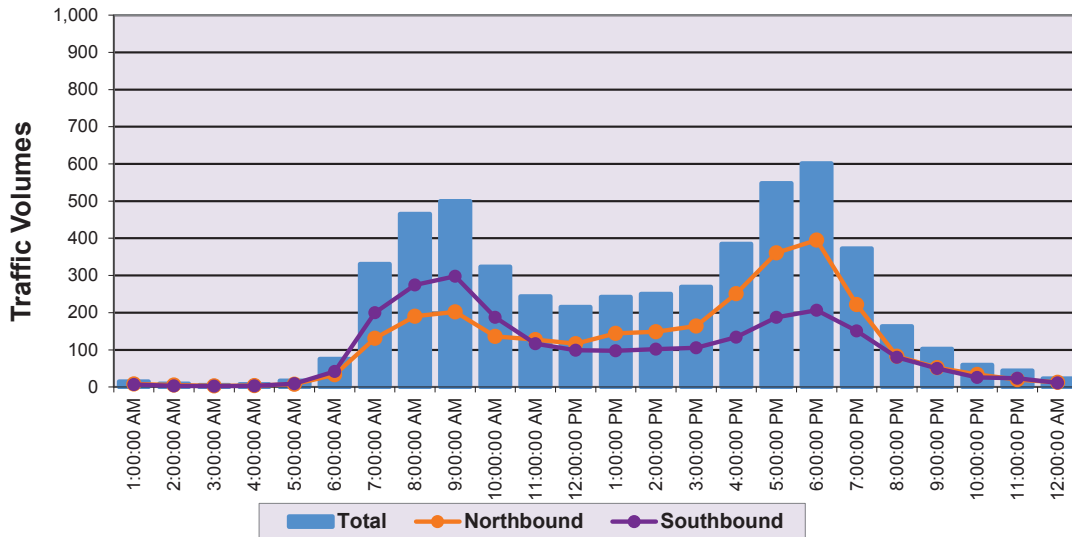

Hour Ending	Average Weekday Volumes		
	Eastbound	Westbound	Total
1:00 AM	8	7	15
2:00 AM	5	3	9
3:00 AM	3	2	5
4:00 AM	4	3	7
5:00 AM	8	9	17
6:00 AM	33	42	75
7:00 AM	131	200	331
8:00 AM	191	275	465
9:00 AM	202	298	500
10:00 AM	136	187	324
11:00 AM	128	116	244
12:00 PM	117	99	216

Hour Ending	Average Weekday Volumes		
	Eastbound	Westbound	Total
1:00 PM	145	97	242
2:00 PM	149	102	251
3:00 PM	164	106	270
4:00 PM	251	134	385
5:00 PM	361	187	548
6:00 PM	395	206	602
7:00 PM	222	151	373
8:00 PM	83	80	163
9:00 PM	52	50	102
10:00 PM	34	26	59
11:00 PM	20	24	44
12:00 AM	12	11	23

Total Eastbound	2,854
Total Westbound	2,416
Total Weekday	5,270



Mt. Plymouth Toll Gantry
SR 429 - Wekiva Parkway
 Typical Average Seven Day Hourly Traffic - April 2018

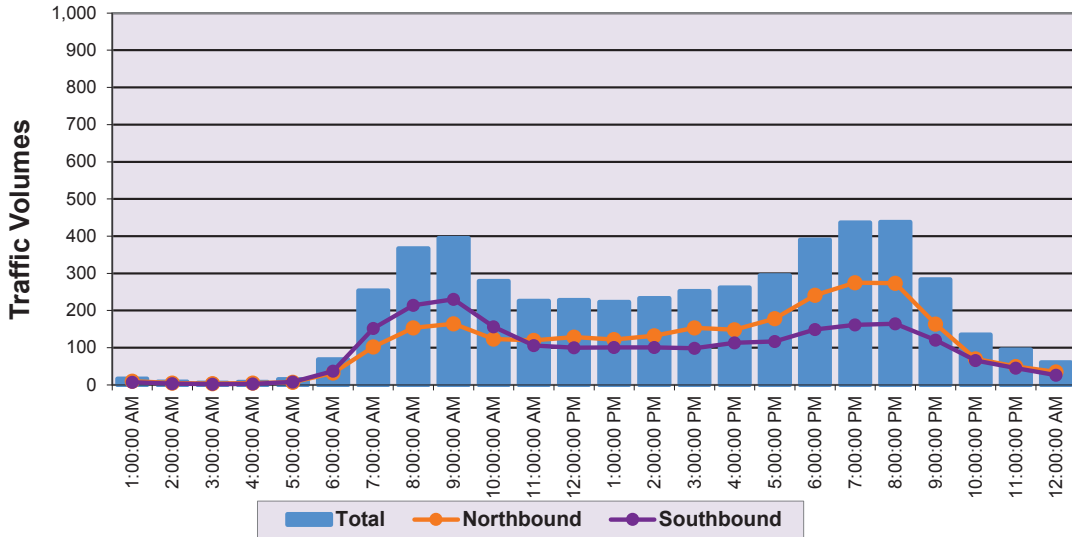

Hour Ending	Average Weekday Volumes		
	Eastbound	Westbound	Total
1:00 AM	10	7	17
2:00 AM	5	4	9
3:00 AM	4	2	6
4:00 AM	5	3	8
5:00 AM	7	8	15
6:00 AM	32	37	69
7:00 AM	102	152	254
8:00 AM	153	214	367
9:00 AM	164	230	395
10:00 AM	124	156	280
11:00 AM	120	106	226
12:00 PM	129	100	228

Hour Ending	Average Weekday Volumes		
	Eastbound	Westbound	Total
1:00 PM	122	101	223
2:00 PM	132	101	233
3:00 PM	153	99	252
4:00 PM	148	113	261
5:00 PM	178	117	295
6:00 PM	241	149	390
7:00 PM	275	162	436
8:00 PM	273	165	438
9:00 PM	163	120	283
10:00 PM	70	65	135
11:00 PM	50	45	95
12:00 AM	35	26	60

Total Eastbound	2,694
Total Westbound	2,279
Total Weekday	4,973



Mt. Plymouth Toll Gantry

Toll Facility Peak Hour Characteristic Summary Typical Average Weekday (Monday through Friday) - April 2018

Average Weekday Traffic Summary (unadjusted)

Average Weekday Total Traffic	5,270
Eastbound Directional Traffic	2,854
Westbound Directional Traffic	2,416

Morning Peak Hour Summary (7:00 a.m. to 8:00 a.m.)

Eastbound Directional Traffic	191
Westbound Directional Traffic	275
Total AM Peak Hour Traffic	465

AM Peak Hour Factor ("K") = Total Peak Hour Traffic / Average Weekday Total Traffic

AM Peak Hour Factor ("K_{am}") **8.83%**

AM Peak Hour Directional Factor ("D") = Peak Directional Traffic / Total Peak Hour Traffic

AM Peak Hour Directional Factor ("D_{am}") **59.03%**

Evening Peak Hour Summary (5:00 p.m. to 6:00 p.m.)

Eastbound Directional Traffic	395
Westbound Directional Traffic	206
Total PM Peak Hour Traffic	602

PM Peak Hour Factor ("K") = Total Peak Hour Traffic / Average Weekday Total Traffic

PM Peak Hour Factor ("K_{pm}") **11.42%**

PM Peak Hour Directional Factor ("D") = Peak Directional Traffic / Total Peak Hour Traffic

PM Peak Hour Directional Factor ("D_{pm}") **65.70%**

Mt. Plymouth Toll Gantry

Toll Transaction Summary

Typical Average Weekday (Monday through Friday) - April 2018

Average Weekday Summary

Direction of Travel	E-PASS (AVI)		Pay-By-Plate		Total	
	Volume	% Usage	Volume	% Usage	Traffic	% Usage
Eastbound	2,217	78%	637	22%	2,854	100%
Westbound	1,896	78%	520	22%	2,416	100%

Morning Peak Hour Summary (7:00 a.m. to 8:00 a.m.)

Direction of Travel	E-PASS (AVI)		Pay-By-Plate		Total	
	Volume	% Usage	Volume	% Usage	Traffic	% Usage
Eastbound	158	83%	33	17%	191	100%
Westbound	219	80%	56	20%	275	100%

Evening Peak Hour Summary (5:00 p.m. to 6:00 p.m.)

Direction of Travel	E-PASS (AVI)		Pay-By-Plate		Total	
	Volume	% Usage	Volume	% Usage	Traffic	% Usage
Eastbound	306	77%	89	23%	395	100%
Westbound	168	81%	38	19%	206	100%

Mt. Plymouth Toll Gantry
SR 429 - Wekiva Parkway
Historical & Existing Toll Transactions Statistics

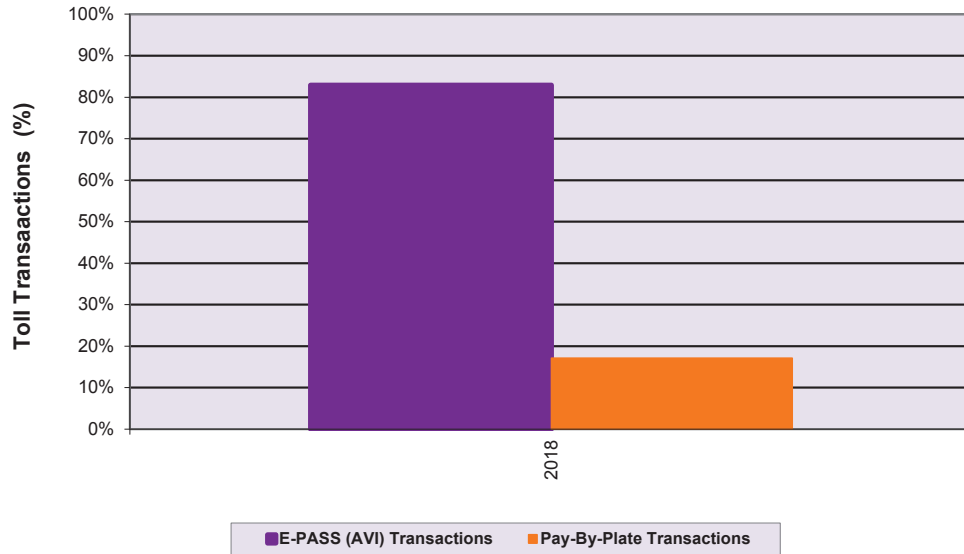

Year	Yearly Historical Toll Transaction Statistics	
	E-PASS (AVI) Transactions	Pay-By-Plate Transactions
2018	82.9%	17.1%

1. In FY 18, all plazas had tolls suspended from September 5, 2017 to September 21, 2017 due to Hurricane Irma.
2. Mt. Plymouth Toll Gantry opened to traffic on April 1, 2018.

Coronado Toll Gantry Facility (SR 453)



2018 Traffic Data and Statistics Manual
CENTRAL FLORIDA EXPRESSWAY AUTHORITY

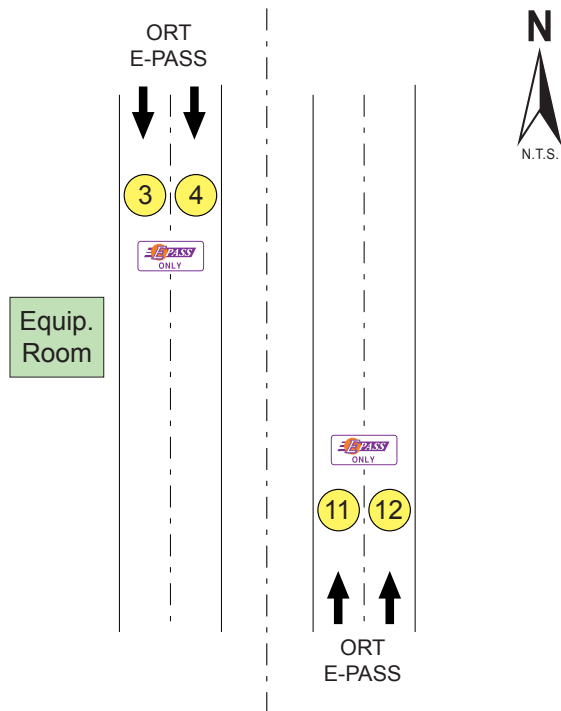

HISTORIC TRAFFIC - A.A.W.T.

2018 7,790* (Toll Increase July 2018)

TOLL RATE STRUCTURE

	<u>E-PASS</u>	<u>PAY-BY-PLATE</u>
2 Axles	\$.66	\$ 1.25
3 Axles	\$ 1.00	\$ 1.59
4 Axles	\$ 1.33	\$ 1.92
5 Axles or more	\$ 1.67	\$ 2.26

(Toll Rates Effective July 1, 2019)

LANES OF EQUIPMENT

- 4 Open Road Tolling (ORT) E-PASS and Pay-by-Plate (PBP)

LEGEND

- ① Lane Number

* Opened to traffic April 1, 2018.





Not to Scale
Google Earth
February 2019



Coronado Toll Gantry SR 453 - Wekiva Parkway

Fiscal Year 2018 Monthly Mainline & Ramp Toll Transactions and Revenue Summary

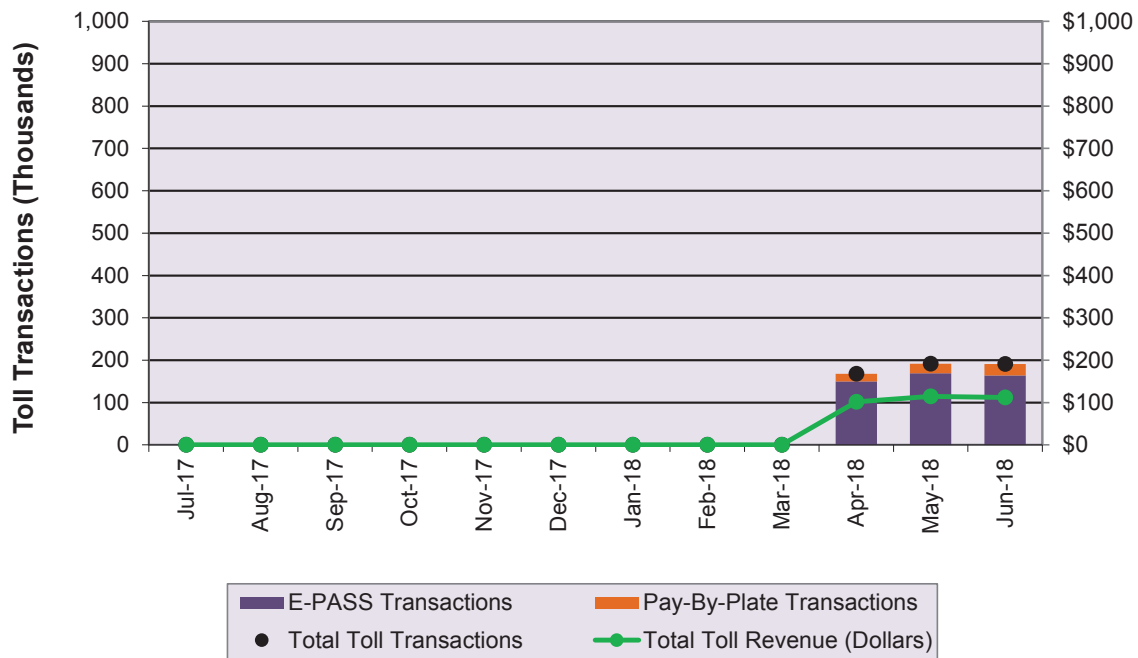

Month	FY 18 MONTHLY MAINLINE & RAMP TOLL TRANSACTIONS			Total Toll Revenue
	E-PASS	Pay-By-Plate	Total	
July-17	No Data	No Data	No Data	No Data
August-17	No Data	No Data	No Data	No Data
September-17	No Data	No Data	No Data	No Data
October-17	No Data	No Data	No Data	No Data
November-17	No Data	No Data	No Data	No Data
December-17	No Data	No Data	No Data	No Data
January-18	No Data	No Data	No Data	No Data
February-18	No Data	No Data	No Data	No Data
March-18	No Data	No Data	No Data	No Data
April-18	149,977	17,915	167,892	\$101,787
May-18	168,875	22,523	191,398	\$114,767
June-18	164,015	27,245	191,260	\$111,722
Yearly Totals	482,867	67,683	550,550	\$328,276

Note: Data includes ramp toll plazas that report to the Coronado Mainline Gantry

1. Pay-By-Plate transactions are calculated as the difference between total revenue traffic and E-PASS traffic.
2. Coronado Toll Gantry opened to traffic on April 1, 2018.



Coronado Toll Gantry

SR 453 - Wekiva Parkway

Typical Daily Expressway Traffic Volumes - April 2018

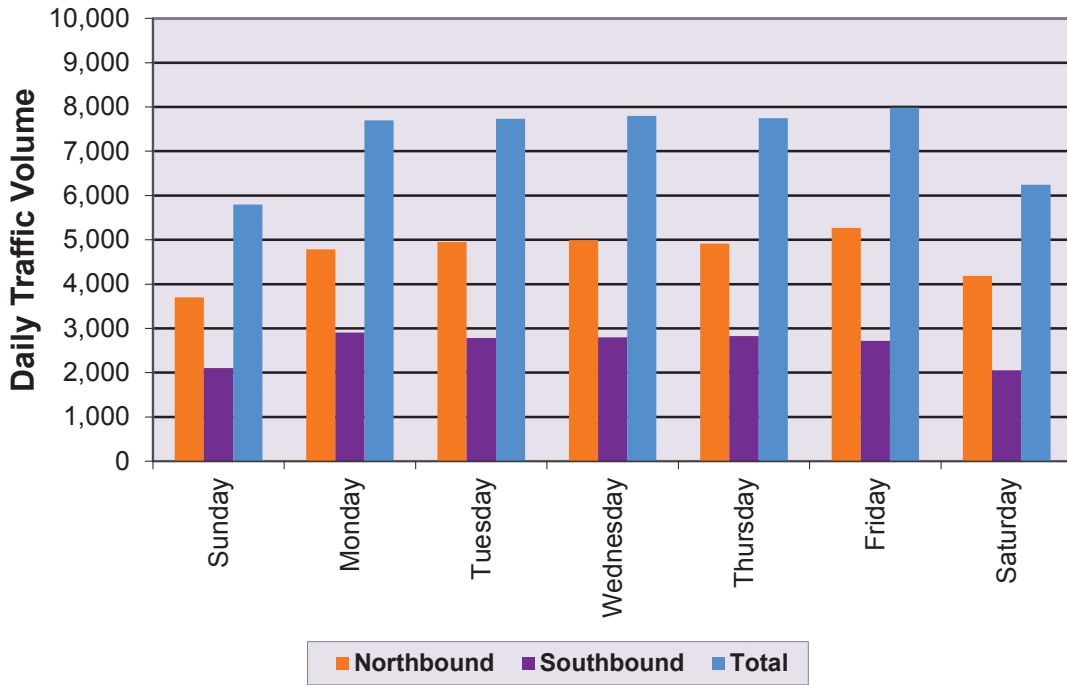

Day	Expressway Traffic Volumes		
	Northbound	Southbound	Total
Sunday	3,698	2,100	5,798
Monday	4,785	2,909	7,694
Tuesday	4,953	2,781	7,734
Wednesday	4,996	2,799	7,795
Thursday	4,918	2,827	7,745
Friday	5,269	2,718	7,987
Saturday	4,186	2,056	6,242

Coronado Toll Gantry

SR 453 - Wekiva Parkway

Typical Average Five Day Hourly Traffic - April 2018

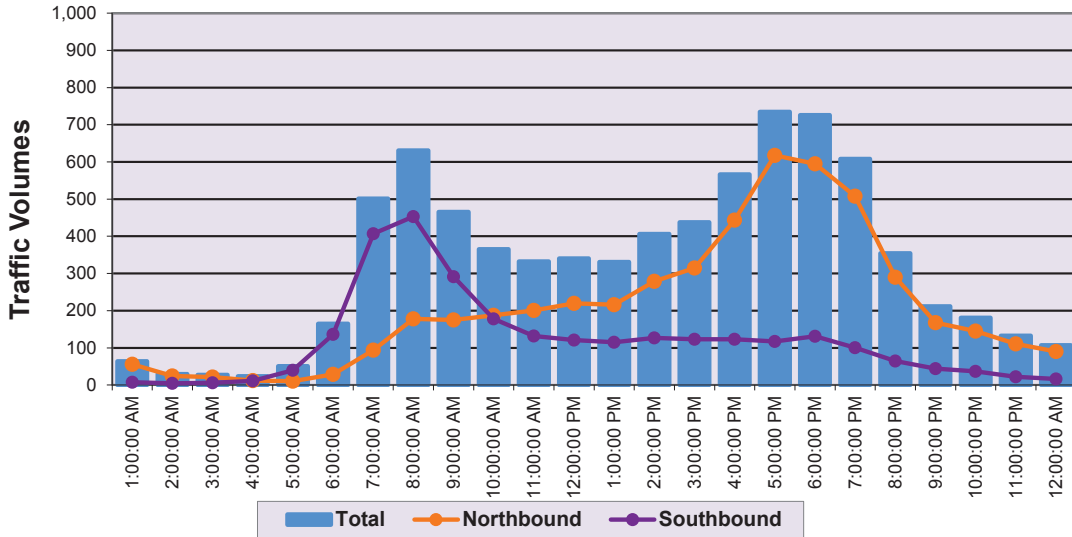

Hour Ending	Average Weekday Volumes		
	Northbound	Southbound	Total
1:00 AM	56	8	64
2:00 AM	25	5	29
3:00 AM	21	6	27
4:00 AM	12	11	23
5:00 AM	10	40	50
6:00 AM	28	136	165
7:00 AM	94	407	501
8:00 AM	178	453	631
9:00 AM	175	291	466
10:00 AM	188	178	366
11:00 AM	201	132	333
12:00 PM	220	121	341

Hour Ending	Average Weekday Volumes		
	Northbound	Southbound	Total
1:00 PM	216	115	331
2:00 PM	279	127	406
3:00 PM	315	123	438
4:00 PM	444	123	567
5:00 PM	618	117	735
6:00 PM	595	131	726
7:00 PM	508	100	608
8:00 PM	290	65	354
9:00 PM	168	44	212
10:00 PM	145	36	181
11:00 PM	111	22	133
12:00 AM	90	16	107

Total Northbound	4,984
Total Southbound	2,807
Total Weekday	7,791



Coronado Toll Gantry

SR 453 - Wekiva Parkway

Typical Average Seven Day Hourly Traffic - April 2018

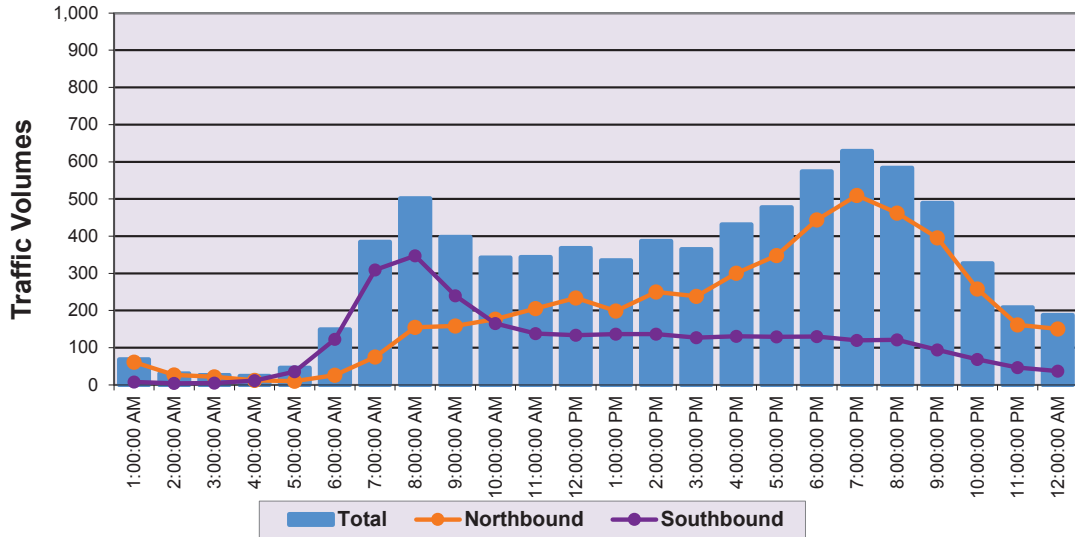

Hour Ending	Average Weekday Volumes		
	Northbound	Southbound	Total
1:00 AM	61	8	69
2:00 AM	27	4	31
3:00 AM	22	5	26
4:00 AM	12	11	24
5:00 AM	10	35	46
6:00 AM	26	123	149
7:00 AM	75	309	384
8:00 AM	155	347	502
9:00 AM	158	240	398
10:00 AM	177	165	342
11:00 AM	205	138	343
12:00 PM	234	134	368

Hour Ending	Average Weekday Volumes		
	Northbound	Southbound	Total
1:00 PM	199	136	335
2:00 PM	250	137	386
3:00 PM	238	127	365
4:00 PM	301	131	431
5:00 PM	348	129	477
6:00 PM	444	130	574
7:00 PM	509	120	629
8:00 PM	462	121	584
9:00 PM	395	94	489
10:00 PM	258	68	327
11:00 PM	161	47	208
12:00 AM	151	37	188

Total Northbound	4,879
Total Southbound	2,797
Total Weekday	7,676



Coronado Toll Gantry

Toll Facility Peak Hour Characteristic Summary Typical Average Weekday (Monday through Friday) - April 2018

Average Weekday Traffic Summary (unadjusted)

Average Weekday Total Traffic	7,791
Northbound Directional Traffic	4,984
Southbound Directional Traffic	2,807

Morning Peak Hour Summary (7:00 a.m. to 8:00 a.m.)

Northbound Directional Traffic	178
Southbound Directional Traffic	453
Total AM Peak Hour Traffic	631

AM Peak Hour Factor ("K") = Total Peak Hour Traffic / Average Weekday Total Traffic

AM Peak Hour Factor ("K_{am}") **8.10%**

AM Peak Hour Directional Factor ("D") = Peak Directional Traffic / Total Peak Hour Traffic

AM Peak Hour Directional Factor ("D_{am}") **71.82%**

Evening Peak Hour Summary (5:00 p.m. to 6:00 p.m.)

Northbound Directional Traffic	595
Southbound Directional Traffic	131
Total PM Peak Hour Traffic	726

PM Peak Hour Factor ("K") = Total Peak Hour Traffic / Average Weekday Total Traffic

PM Peak Hour Factor ("K_{pm}") **9.31%**

PM Peak Hour Directional Factor ("D") = Peak Directional Traffic / Total Peak Hour Traffic

PM Peak Hour Directional Factor ("D_{pm}") **81.95%**

Coronado Toll Gantry

Toll Transaction Summary

Typical Average Weekday (Monday through Friday) - April 2018

Average Weekday Summary

Direction of Travel	E-PASS (AVI)		Pay-By-Plate		Total	
	Volume	% Usage	Volume	% Usage	Traffic	% Usage
Northbound	4,319	87%	666	13%	4,984	100%
Southbound	2,458	88%	349	12%	2,807	100%

Morning Peak Hour Summary (7:00 a.m. to 8:00 a.m.)

Direction of Travel	E-PASS (AVI)		Pay-By-Plate		Total	
	Volume	% Usage	Volume	% Usage	Traffic	% Usage
Northbound	156	88%	22	12%	178	100%
Southbound	412	91%	41	9%	453	100%

Evening Peak Hour Summary (5:00 p.m. to 6:00 p.m.)

Direction of Travel	E-PASS (AVI)		Pay-By-Plate		Total	
	Volume	% Usage	Volume	% Usage	Traffic	% Usage
Northbound	527	89%	67	11%	595	100%
Southbound	114	87%	17	13%	131	100%

Coronado Toll Gantry
SR 453 - Wekiva Parkway
 Historical & Existing Toll Transactions Statistics

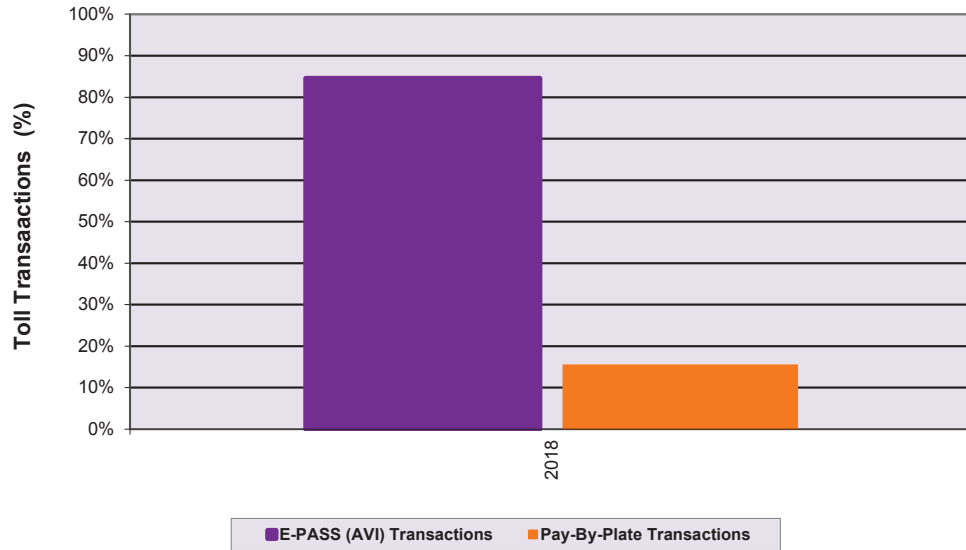

Year	Yearly Historical Toll Transaction Statistics	
	E-PASS (AVI) Transactions	Pay-By-Plate Transactions
2018	84.6%	15.4%

1. In FY 18, all plazas had tolls suspended from September 5, 2017 to September 21, 2017 due to Hurricane Irma.
2. Coronado Toll Gantry opened to traffic on April 1, 2018.

Goldenrod Mainline Toll Facility (Goldenrod Road Extension)

2018 Traffic Data and Statistics Manual
CENTRAL FLORIDA EXPRESSWAY AUTHORITY

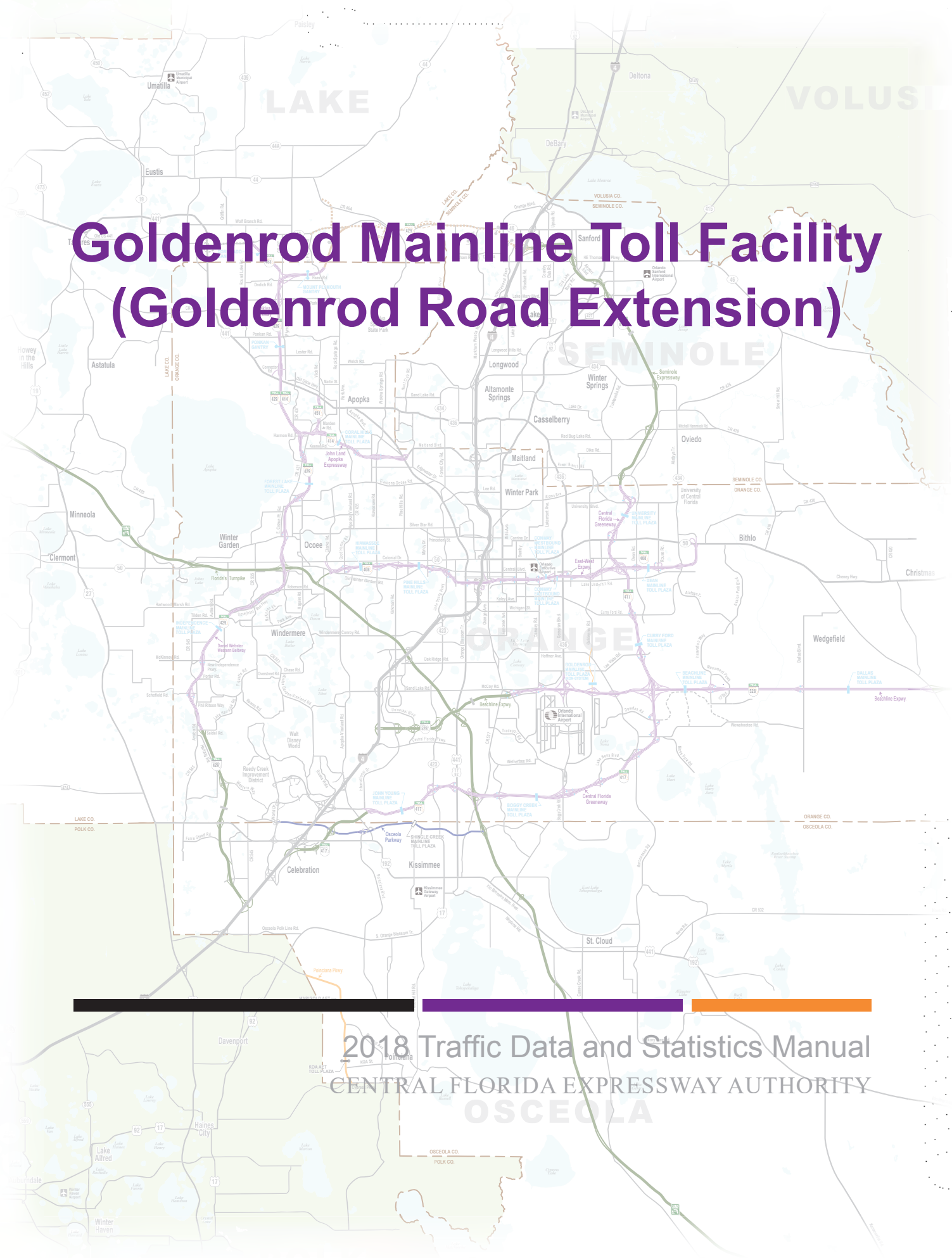

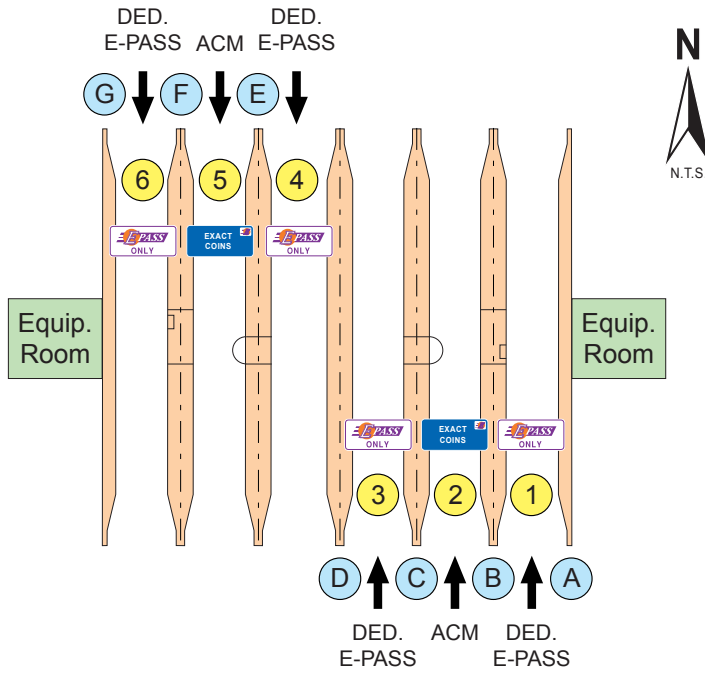

HISTORIC TRAFFIC - A.A.W.T.

2016	12,000
2017	13,510
2018	14,340 (Toll Increase July 2018)

TOLL RATE STRUCTURE

	E-PASS	CASH
All Vehicles	\$.50	\$.50

(Toll Rates Effective July 1, 2019)

LANES OF EQUIPMENT

- 2 Booths with Automatic Coin Machines (ACM) and E-PASS
- 4 Dedicated E-PASS only

LEGEND

- ① Lane Number
- Ⓐ Island Designation



Approx. Scale: 1" = 200'
January 2018

Goldenrod Mainline Toll Facility

Goldenrod Road Extension

Fiscal Year 2018 Monthly Mainline & Ramp Toll Transactions and Revenue Summary

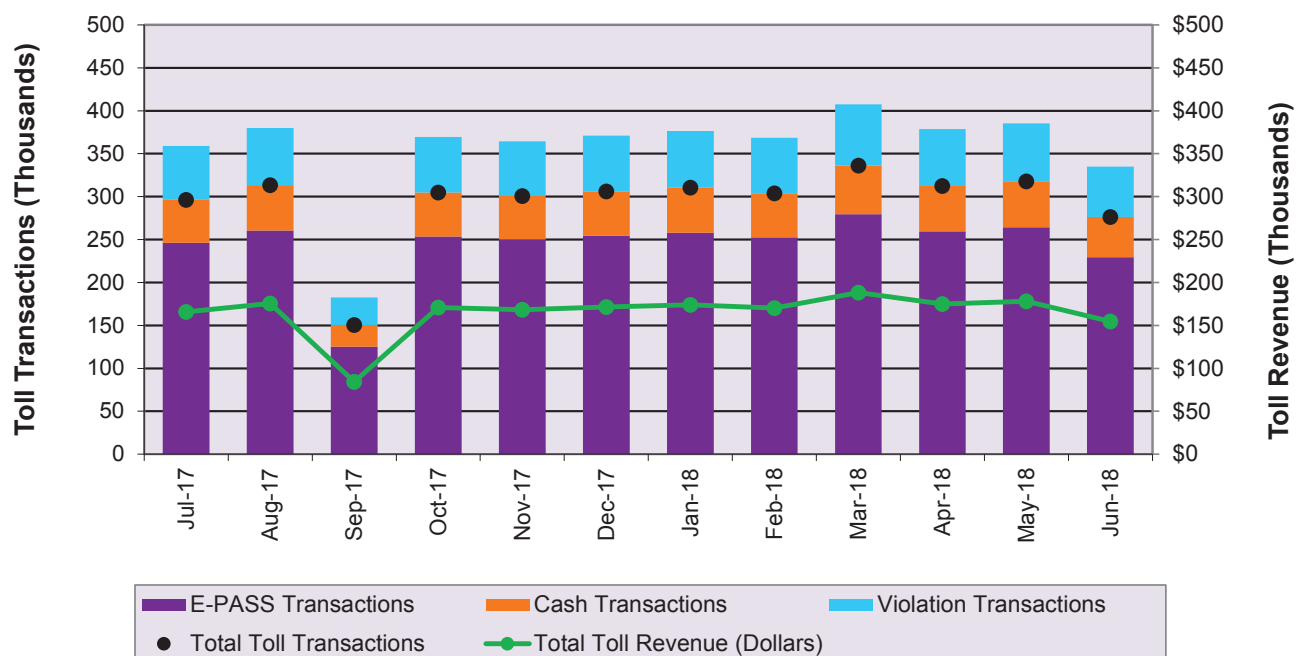

Month	FY 18 MONTHLY MAINLINE & RAMP TOLL TRANSACTIONS					Total Toll Revenue
	E-PASS	Cash	Total Revenue	Violations	Total	
July-17	246,135	50,056	296,191	62,793	358,984	\$165,867
August-17	260,468	52,971	313,439	66,449	379,888	\$175,526
September-17	125,177	25,457	150,634	31,934	182,568	\$84,355
October-17	253,400	51,534	304,934	64,646	369,580	\$170,763
November-17	249,900	50,822	300,721	63,753	364,474	\$168,404
December-17	254,451	51,747	306,198	64,914	371,112	\$171,471
January-18	258,070	52,484	310,554	65,837	376,391	\$173,910
February-18	252,614	51,374	303,988	64,445	368,433	\$170,233
March-18	279,436	56,829	336,264	71,288	407,552	\$188,308
April-18	259,656	52,806	312,463	66,242	378,705	\$174,979
May-18	264,246	53,740	317,986	67,413	385,399	\$178,072
June-18	229,579	46,689	276,268	58,569	334,837	\$154,710
Yearly Totals	2,933,130	596,509	3,529,639	748,284	4,277,923	\$1,976,598

Note: Transaction Data obtained from CFX Monthly Transaction Report from CFX.

1. Cash transactions are calculated as the difference between total revenue traffic and E-PASS traffic.

2. In FY 18, all plazas had tolls suspended from September 5, 2017 to September 21, 2017 due to Hurricane Irma.



Goldenrod Mainline Toll Facility
Goldenrod Road Extension
 Typical Daily Traffic Volumes - April 2018

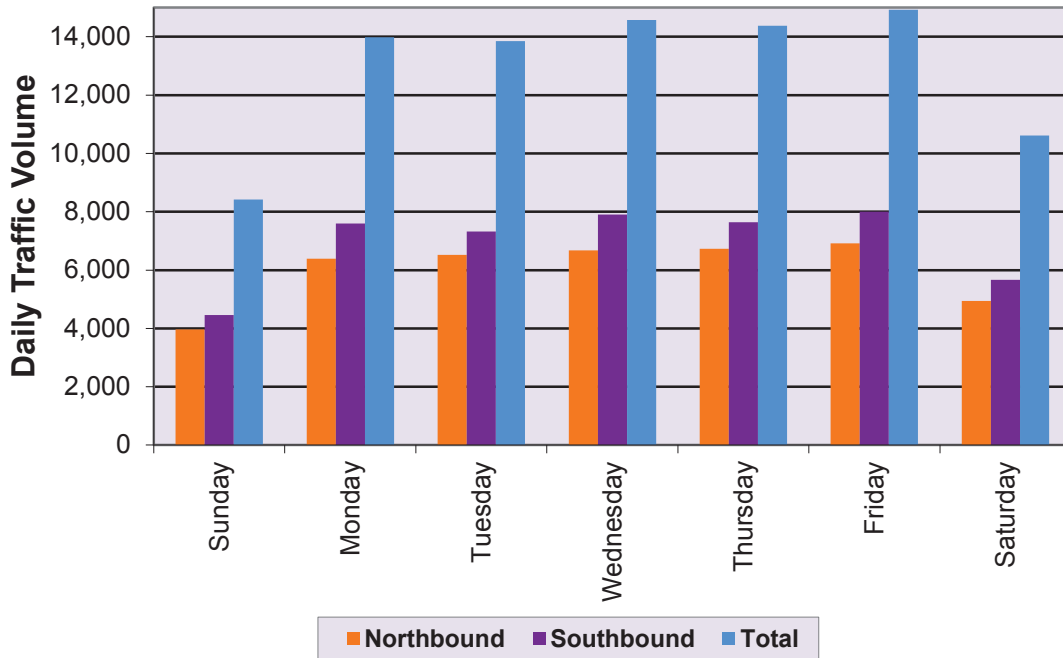

Day	Expressway Traffic Volumes		
	Northbound	Southbound	Total
Sunday	3,964	4,458	8,422
Monday	6,389	7,594	13,983
Tuesday	6,521	7,329	13,850
Wednesday	6,672	7,901	14,573
Thursday	6,735	7,645	14,380
Friday	6,922	8,001	14,923
Saturday	4,943	5,668	10,611

Goldenrod Mainline Toll Facility Goldenrod Extension Average Five Day Hourly Traffic - April 2018

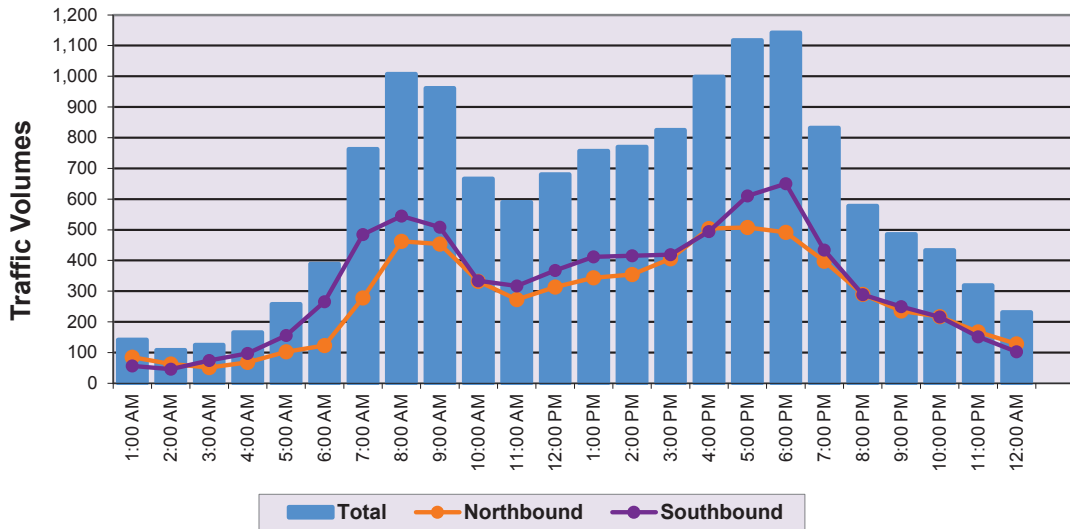

Hour Ending	Average Weekday Volumes		
	Northbound	Southbound	Total
1:00 AM	85	56	141
2:00 AM	62	46	108
3:00 AM	51	74	125
4:00 AM	68	97	166
5:00 AM	102	156	258
6:00 AM	123	266	389
7:00 AM	278	484	763
8:00 AM	462	545	1,007
9:00 AM	453	508	961
10:00 AM	333	334	666
11:00 AM	273	317	590
12:00 PM	313	367	681

Hour Ending	Average Weekday Volumes		
	Northbound	Southbound	Total
1:00 PM	344	412	756
2:00 PM	355	415	770
3:00 PM	406	419	824
4:00 PM	504	495	998
5:00 PM	508	610	1,118
6:00 PM	492	651	1,142
7:00 PM	398	434	832
8:00 PM	289	289	578
9:00 PM	236	249	485
10:00 PM	217	216	433
11:00 PM	168	152	319
12:00 AM	129	103	231

Total Northbound	6,648
Total Southbound	7,694
Total Weekday	14,341



SR 551 (GOLDENROD ROAD EXTENSION) Goldenrod Mainline Toll Plaza

Goldenrod Mainline Toll Facility Goldenrod Road Extension Average Seven Day Hourly Traffic - April 2018

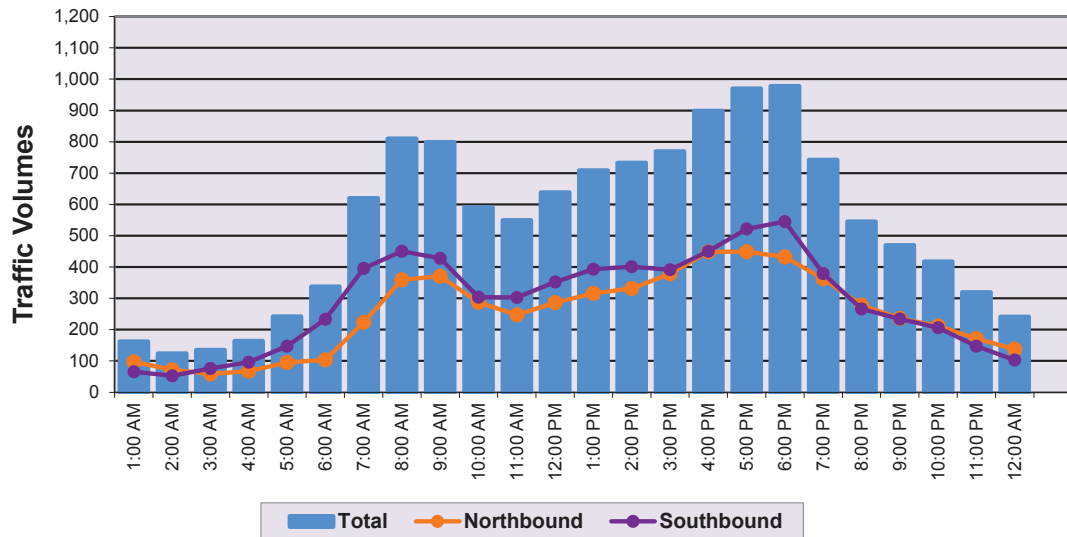

Hour Ending	Average Weekday Volumes		
	Northbound	Southbound	Total
1:00 AM	97	65	162
2:00 AM	71	52	124
3:00 AM	59	76	135
4:00 AM	68	96	164
5:00 AM	95	148	242
6:00 AM	104	233	337
7:00 AM	224	396	620
8:00 AM	360	451	810
9:00 AM	371	428	799
10:00 AM	287	304	591
11:00 AM	247	302	550
12:00 PM	286	353	638

Hour Ending	Average Weekday Volumes		
	Northbound	Southbound	Total
1:00 PM	316	393	708
2:00 PM	332	401	733
3:00 PM	378	392	770
4:00 PM	449	450	899
5:00 PM	449	521	970
6:00 PM	432	545	978
7:00 PM	363	379	742
8:00 PM	279	266	545
9:00 PM	236	234	470
10:00 PM	211	206	417
11:00 PM	172	147	319
12:00 AM	138	103	241

Total Northbound	6,021
Total Southbound	6,942
Total Weekday	12,963



SR 551 (GOLDENROD ROAD EXTENSION) Goldenrod Mainline Toll Plaza

SECTION III

Goldenrod Mainline Toll Facility

Toll Facility Peak Hour Characteristic Summary Typical Average Weekday (Monday through Friday) - April 2018

Average Weekday Traffic Summary (unadjusted)

Average Weekday Total Traffic	14,341
Northbound Directional Traffic	6,648
Southbound Directional Traffic	7,694

Morning Peak Hour Summary (7:00 a.m. to 8:00 a.m.)

Northbound Directional Traffic	462
Southbound Directional Traffic	545
Total AM Peak Hour Traffic	1,007

AM Peak Hour Factor ("K") = Total Peak Hour Traffic / Average Weekday Total Traffic

AM Peak Hour Factor ("K_{am}") 7.02%

AM Peak Hour Directional Factor ("D") = Peak Directional Traffic / Total Peak Hour Traffic

AM Peak Hour Directional Factor ("D_{am}") 54.13%

Evening Peak Hour Summary (5:00 p.m. to 6:00 p.m.)

Northbound Directional Traffic	492
Southbound Directional Traffic	651
Total PM Peak Hour Traffic	1,142

PM Peak Hour Factor ("K") = Total Peak Hour Traffic / Average Weekday Total Traffic

PM Peak Hour Factor ("K_{pm}") 7.96%

PM Peak Hour Directional Factor ("D") = Peak Directional Traffic / Total Peak Hour Traffic

PM Peak Hour Directional Factor ("D_{pm}") 56.96%



Goldenrod Mainline Toll Facility

Toll Transaction Summary

Typical Average Weekday (Monday through Friday) - April 2018

Average Weekday Summary

Direction of Travel	E-PASS (AVI)		ACM (Coin)		Manual (Cash)		Total	
	Volume	% Usage	Volume	% Usage	Volume	% Usage	Traffic	% Usage
Northbound	5,816	88%	778	12%	0	0%	6,595	100%
Southbound	6,771	89%	861	11%	0	0%	7,632	100%

Morning Peak Hour Summary (7:00 a.m. to 8:00 a.m.)

Direction of Travel	E-PASS (AVI)		ACM (Coin)		Manual (Cash)		Total	
	Volume	% Usage	Volume	% Usage	Volume	% Usage	Traffic	% Usage
Northbound	429	93%	32	7%	0	0%	461	100%
Southbound	497	92%	44	8%	0	0%	541	100%

Evening Peak Hour Summary (5:00 p.m. to 6:00 p.m.)

Direction of Travel	E-PASS (AVI)		ACM (Coin)		Manual (Cash)		Total	
	Volume	% Usage	Volume	% Usage	Volume	% Usage	Traffic	% Usage
Northbound	425	87%	63	13%	0	0%	487	100%
Southbound	593	92%	54	8%	0	0%	647	100%



Goldenrod Mainline Toll Facility
Goldenrod Road Extension
Historical & Existing Total Revenue Transactions Statistics

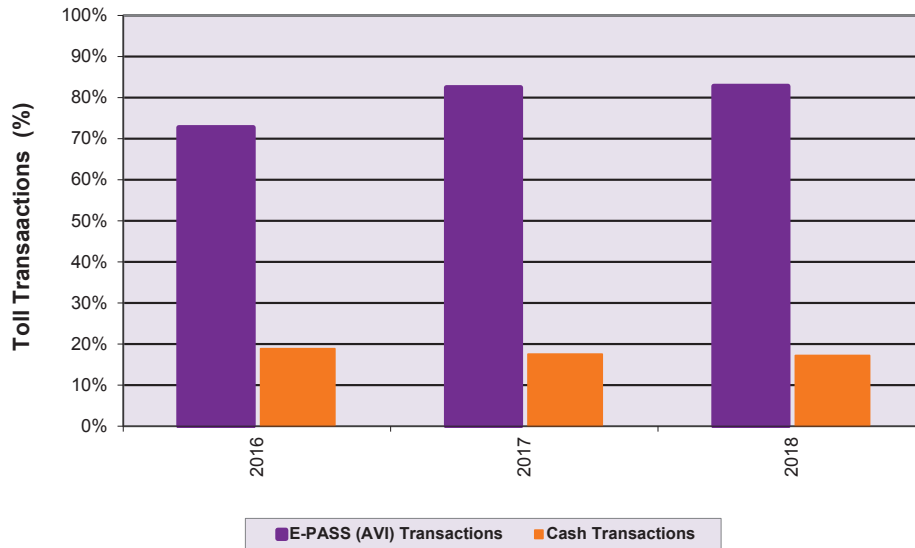

Year	Yearly Revenue Transaction		% Violations ⁽²⁾ (Percent of Total Transactions)
	% E-PASS (AVI) Transactions	% Cash Transactions	
2016	72.7%	18.9%	8.4%
2017	82.5%	17.5%	19.7%
2018	82.8%	17.2%	17.5%

1. In FY 18, all plazas had tolls suspended from September 5, 2017 to September 21, 2017 due to Hurricane Irma.
2. Calculated as percentage of Total Transactions, which is equal to Revenue Transactions plus Violations.



Section IV: Interchanges

2018 Traffic Data and Statistics Manual
CENTRAL FLORIDA EXPRESSWAY AUTHORITY

East-West Expressway



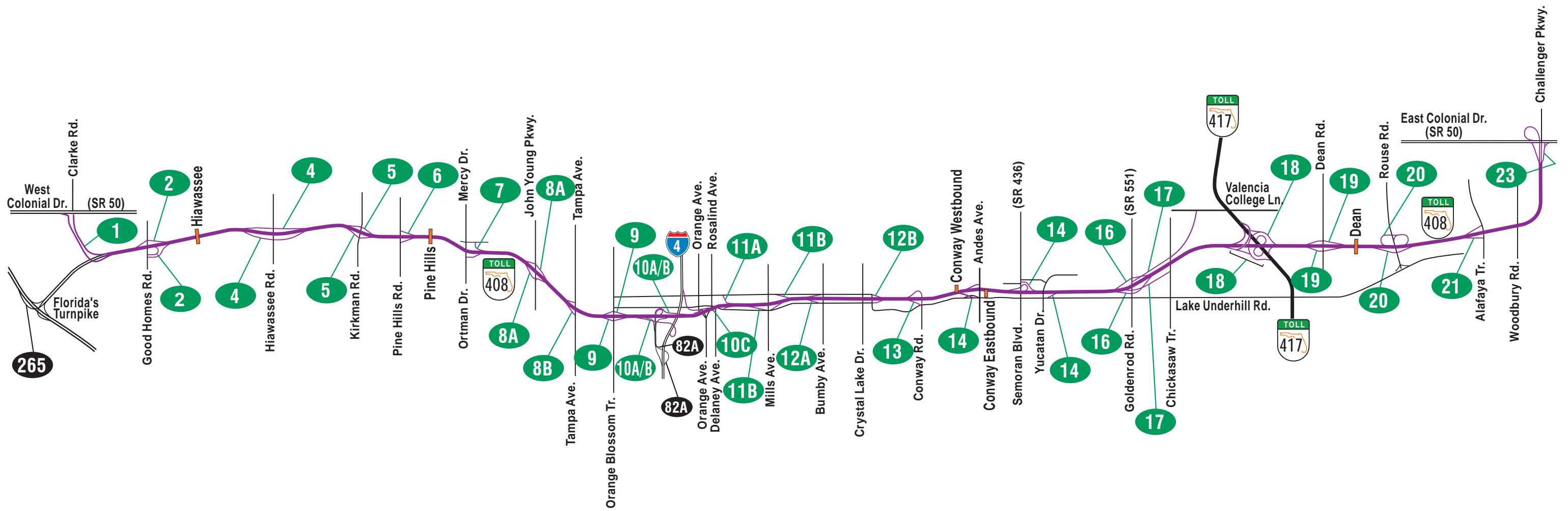

LEGEND

- Exit Number
- Existing SR 408
- Mainline Toll Plaza



SR 408 - EAST-WEST EXPRESSWAY
Exit Numbers



LEGEND

- <1 No. of Lanes
- Approach Lane Use
- 🚦 STOP Traffic Control
- 🟡 Toll Plaza
- ## 2018 AAWT

RAMP DESCRIPTION

- Ⓐ EB On Ramp
- Ⓑ WB Off Ramp
- Ⓒ EB from FL Turnpike
- Ⓓ WB to FL Turnpike

Aerial Date: January 2018



SR 408 (EAST-WEST EXPRESSWAY)
Exit 1 - SR 50/Clarke Road Spur

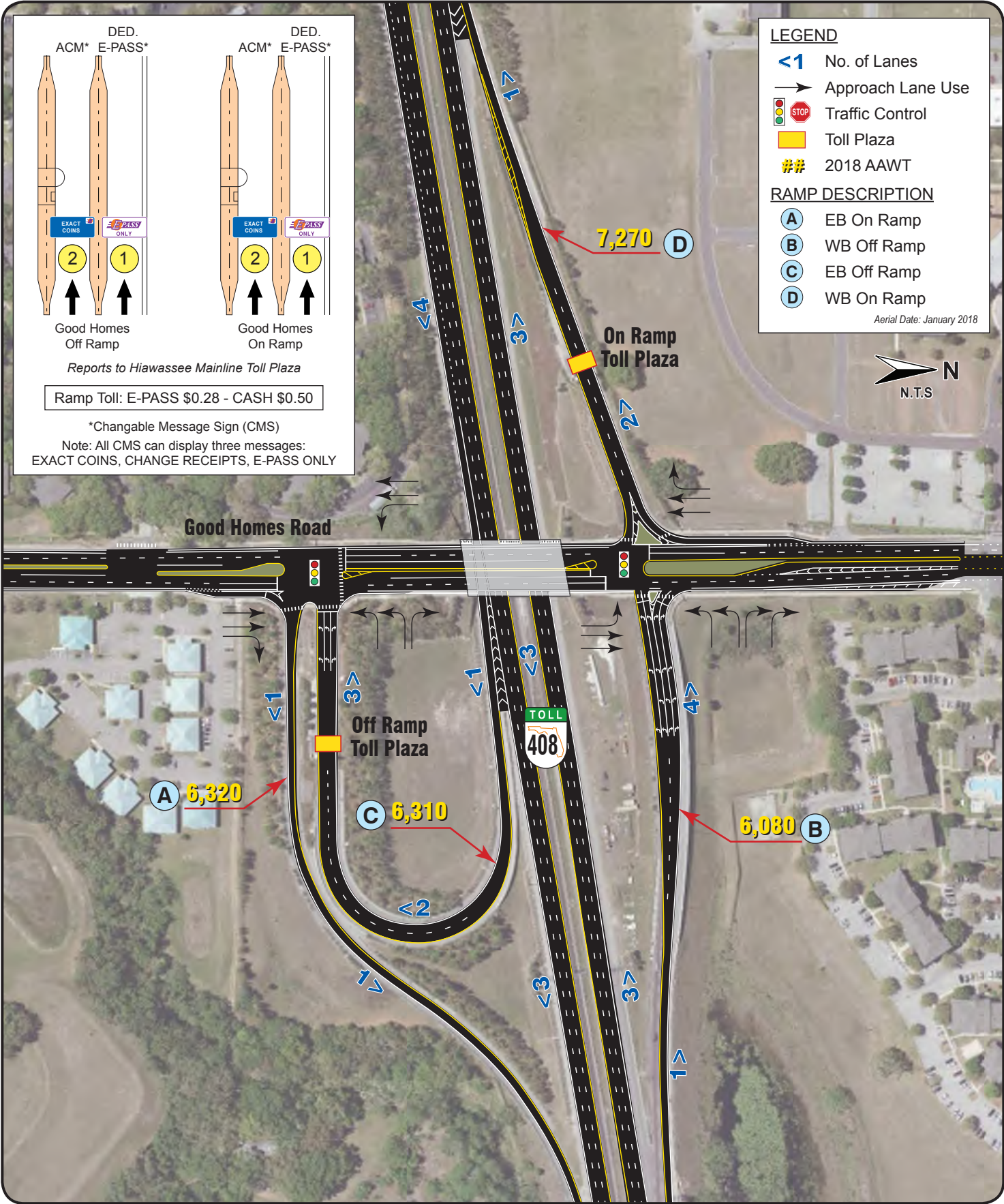

LEGEND

- <1> No. of Lanes
- ➔ Approach Lane Use
- 🚦 STOP Traffic Control
- 🟡 Toll Plaza
- ## 2018 AAWT

RAMP DESCRIPTION

- Ⓐ EB On Ramp
- Ⓑ WB Off Ramp
- Ⓒ EB Off Ramp
- Ⓓ WB On Ramp

Aerial Date: January 2018

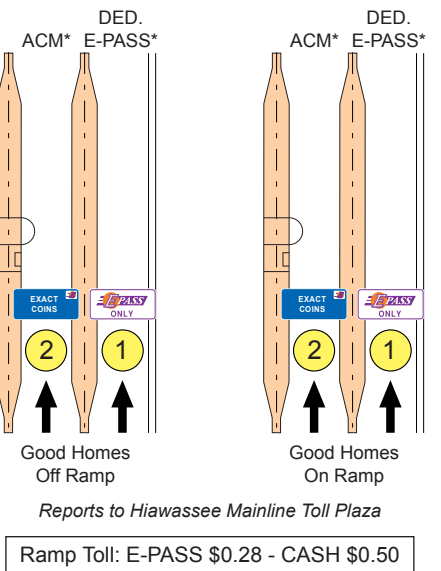

*Changable Message Sign (CMS)

Note: All CMS can display three messages:
EXACT COINS, CHANGE RECEIPTS, E-PASS ONLY



**SR 408 (EAST-WEST EXPRESSWAY)
Exit 2 - Good Homes Road**

SECTION IV

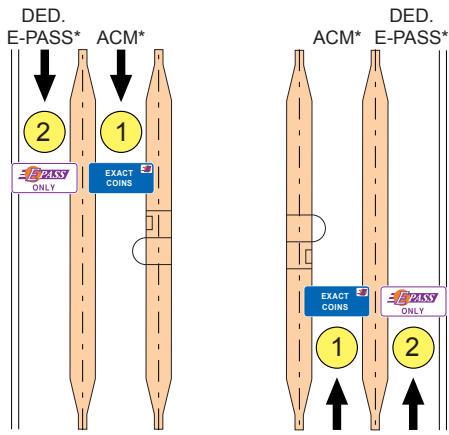

Hiwassee
On Ramp

Hiwassee
Off Ramp

Reports to Hiwassee Mainline Toll Plaza

Ramp Toll: E-PASS \$0.55 - CASH \$0.75

*Changable Message Sign (CMS)

Note: All CMS can display three messages:
EXACT COINS, CHANGE RECEIPTS, E-PASS ONLY

LEGEND

- <1 No. of Lanes
- Approach Lane Use
- STOP Traffic Control
- Toll Plaza
- ## 2018 AAWT



RAMP DESCRIPTION

- (A) EB Off Ramp
- (B) WB On Ramp
- (C) EB On Ramp
- (D) WB Off Ramp

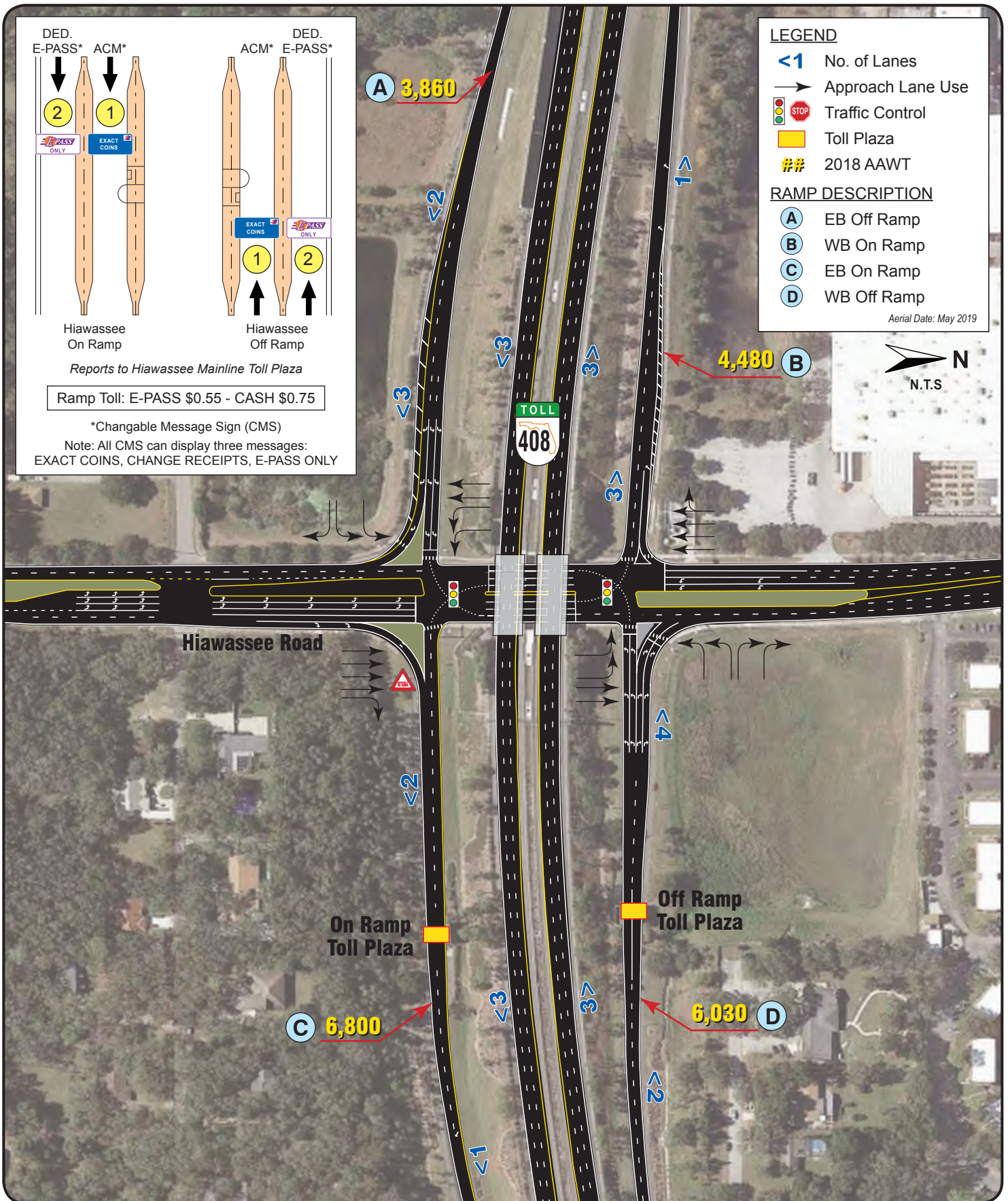
Aerial Date: May 2019



LEGEND

- <1 No. of Lanes
- Approach Lane Use
-  Traffic Control
-  Toll Plaza
- ## 2018 AAWT

RAMP DESCRIPTION

- (A) EB Off Ramp
- (B) WB On Ramp
- (C) EB On Ramp
- (D) WB Off Ramp

Aerial Date: January 2018



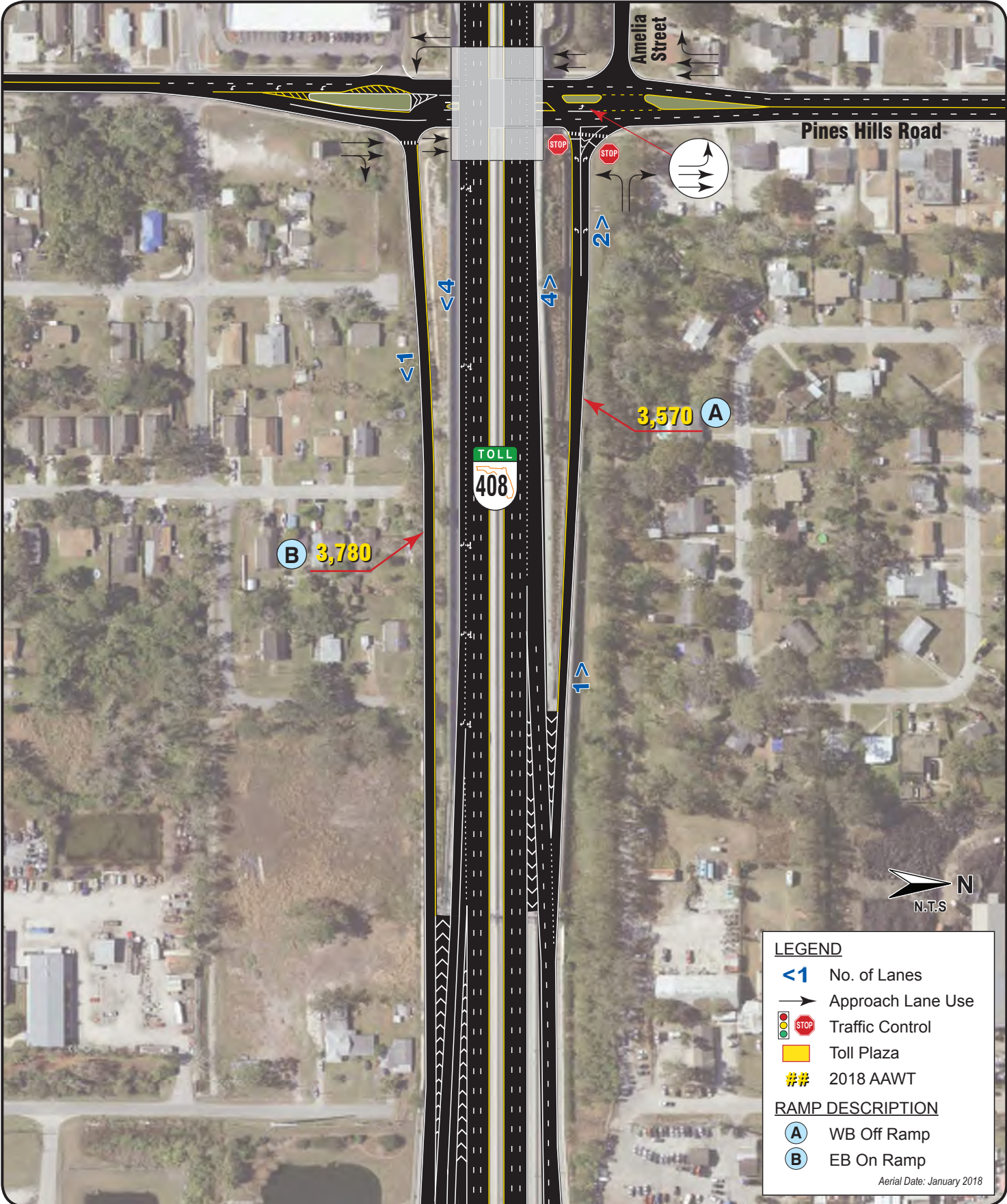

LEGEND

- <1> No. of Lanes
- Approach Lane Use
- STOP Traffic Control
- Yellow Box Toll Plaza
- ## 2018 AAWT

RAMP DESCRIPTION

- (A) WB Off Ramp
- (B) EB On Ramp

Aerial Date: January 2018



**SR 408 (EAST-WEST EXPRESSWAY)
Exit 6 - Pine Hills Road**

SECTION IV

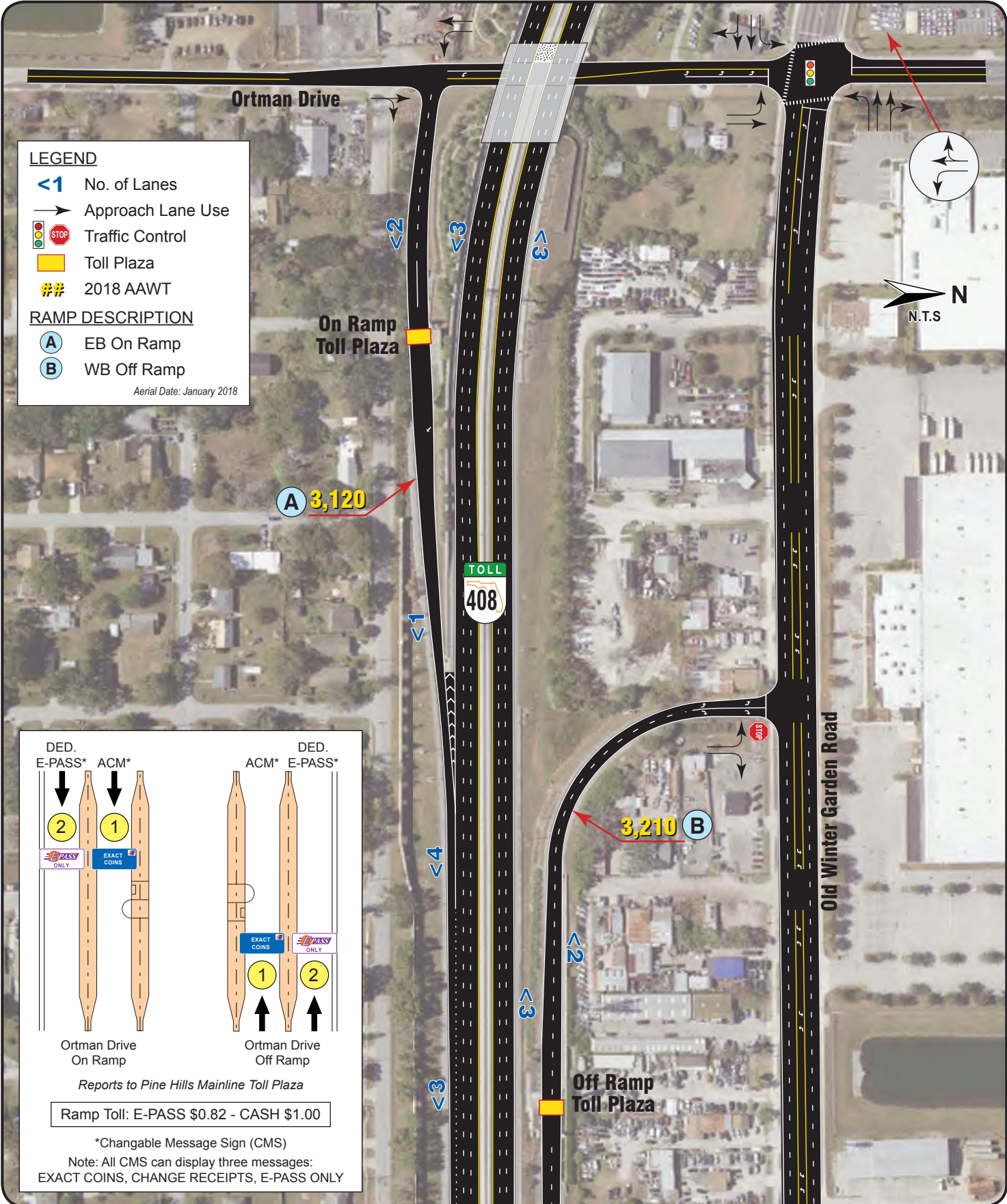

LEGEND

- <1 No. of Lanes
- ➔ Approach Lane Use
- 🚦 Traffic Control
- 🟡 Toll Plaza
- ## 2018 AAWT

RAMP DESCRIPTION

- (A) EB On Ramp
- (B) WB Off Ramp

Aerial Date: January 2018

DED. E-PASS*	ACM*	DED. ACM*	E-PASS*
2	1	1	2
E-PASS ONLY	EXACT COINS	EXACT COINS	E-PASS ONLY
Ortman Drive On Ramp		Ortman Drive Off Ramp	

Reports to Pine Hills Mainline Toll Plaza

Ramp Toll: E-PASS \$0.82 - CASH \$1.00

*Changeable Message Sign (CMS)
 Note: All CMS can display three messages:
 EXACT COINS, CHANGE RECEIPTS, E-PASS ONLY

LEGEND

- <1 No. of Lanes
- Approach Lane Use
- Traffic Control
- Toll Plaza
- ## 2018 AAWT

RAMP DESCRIPTION

- A** EB Off Ramp
- B** EB On Ramp
- C** WB Off Ramp
- D** WB On Ramp

Aerial Date: January 2018

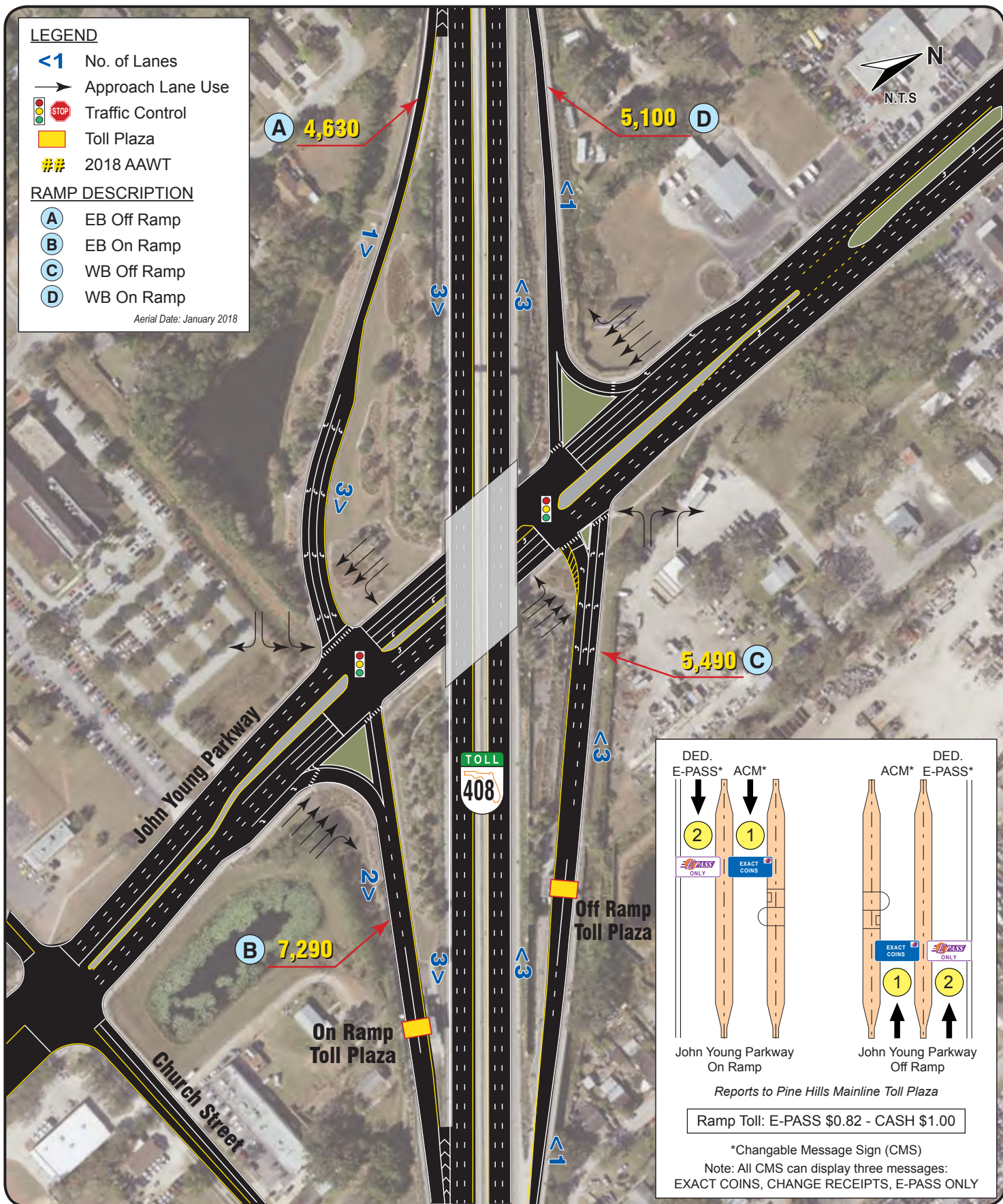

DED. E-PASS*	ACM*	DED. ACM*	E-PASS*
John Young Parkway On Ramp	John Young Parkway On Ramp	John Young Parkway Off Ramp	John Young Parkway Off Ramp

Reports to Pine Hills Mainline Toll Plaza

Ramp Toll: E-PASS \$0.82 - CASH \$1.00



*Changable Message Sign (CMS)
 Note: All CMS can display three messages: EXACT COINS, CHANGE RECEIPTS, E-PASS ONLY





**SR 408 (EAST-WEST EXPRESSWAY)
Exit 8A - John Young Parkway**

SECTION IV

LEGEND

- <1 No. of Lanes
- Approach Lane Use
-   Traffic Control
-  Toll Plaza
- ## 2018 AAWT

RAMP DESCRIPTION

-  EB Off Ramp
-  WB On Ramp

Aerial Date: January 2018

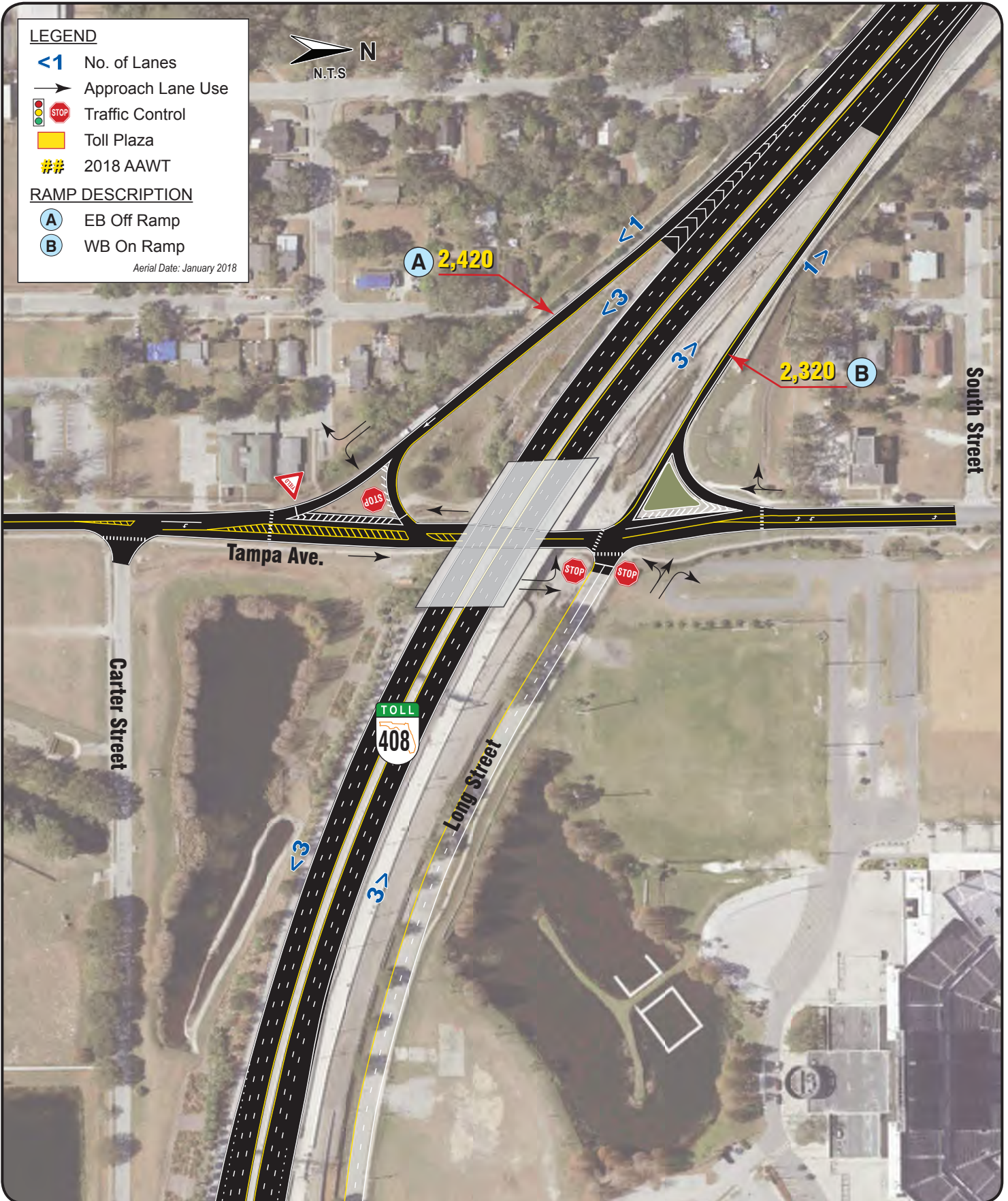

**SR 408 (EAST-WEST EXPRESSWAY)
Exit 8B - Tampa Avenue**

SECTION IV

223

LEGEND

- <1 No. of Lanes
- ➔ Approach Lane Use
- 🚦 STOP Traffic Control
- 🟡 Toll Plaza
- ## 2018 AAWT

RAMP DESCRIPTION

- Ⓐ EB Off Ramp
- Ⓑ WB On Ramp
- Ⓒ EB On Ramp
- Ⓓ WB Off Ramp

Aerial Date: January 2018

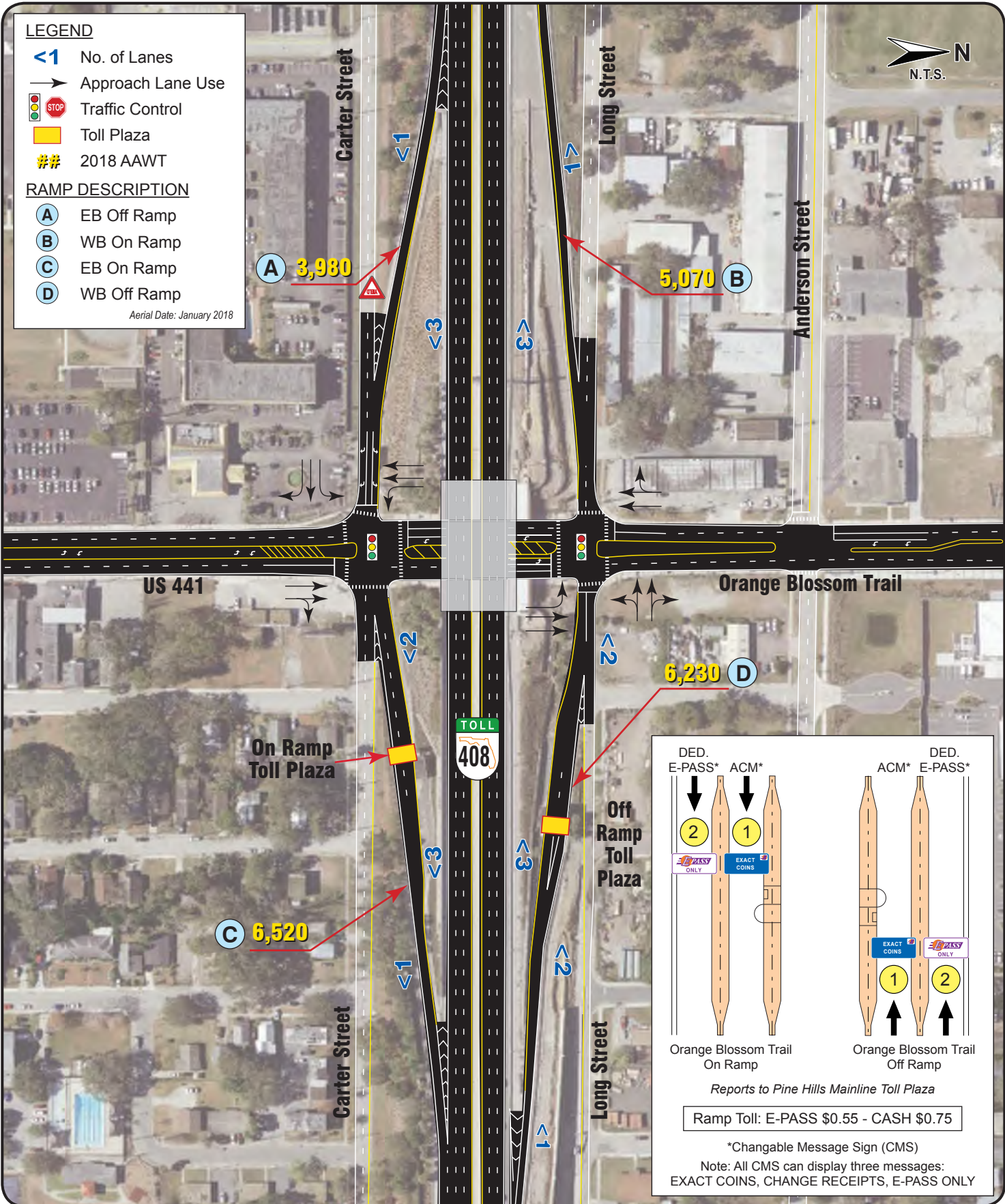

DED. E-PASS*	ACM*	DED. ACM*	E-PASS*
2	1	1	2
Orange Blossom Trail On Ramp		Orange Blossom Trail Off Ramp	

Reports to Pine Hills Mainline Toll Plaza

Ramp Toll: E-PASS \$0.55 - CASH \$0.75

*Changeable Message Sign (CMS)
 Note: All CMS can display three messages: EXACT COINS, CHANGE RECEIPTS, E-PASS ONLY



**SR 408 (EAST-WEST EXPRESSWAY)
Exit 9 - Orange Blossom Trail (US 441)**

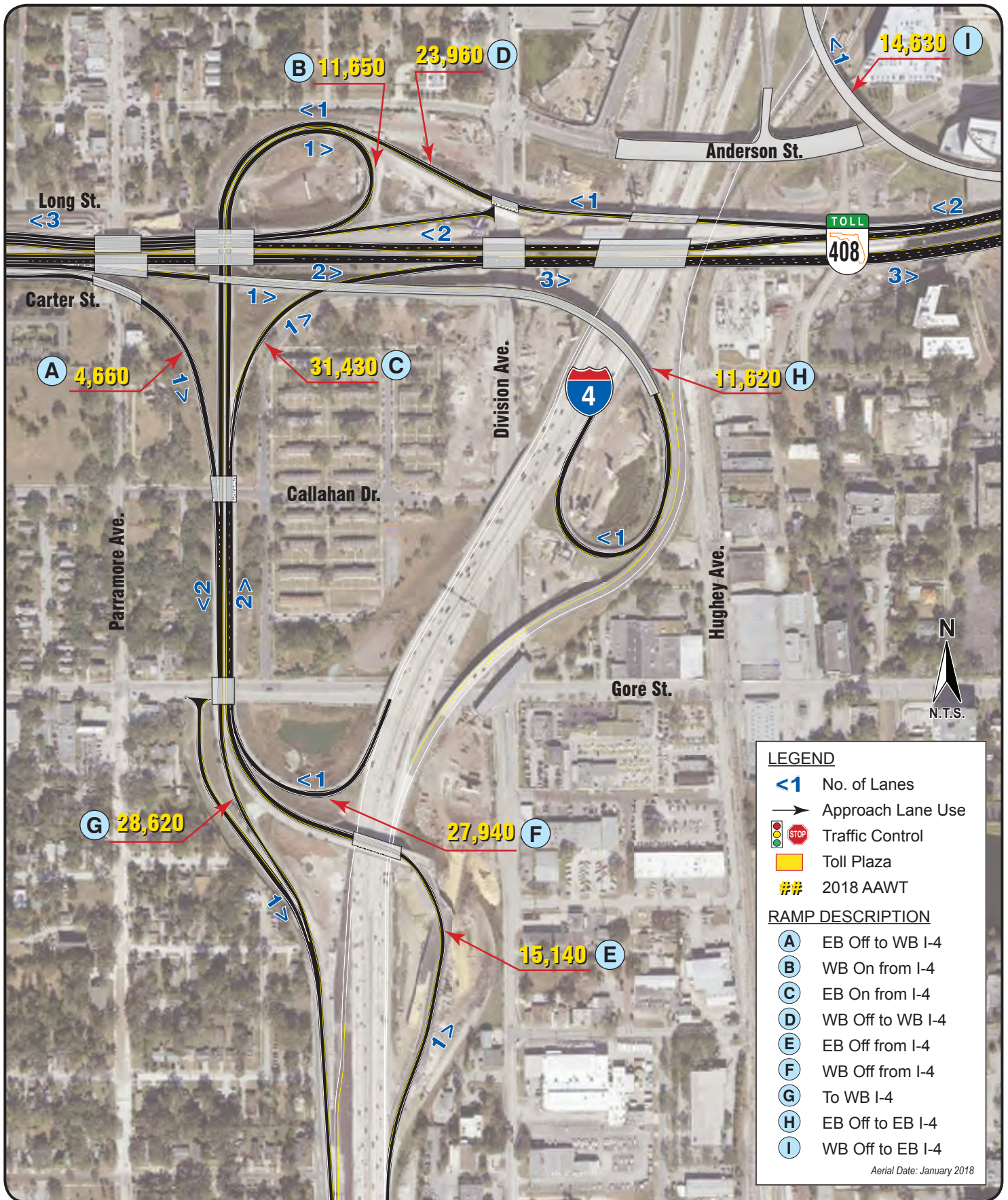

LEGEND

- <1 No. of Lanes
- Approach Lane Use
- Traffic Control
- Toll Plaza
- ## 2018 AAWT

RAMP DESCRIPTION

- A** EB Off to WB I-4
- B** WB On from I-4
- C** EB On from I-4
- D** WB Off to WB I-4
- E** EB Off from I-4
- F** WB Off from I-4
- G** To WB I-4
- H** EB Off to EB I-4
- I** WB Off to EB I-4

Aerial Date: January 2018





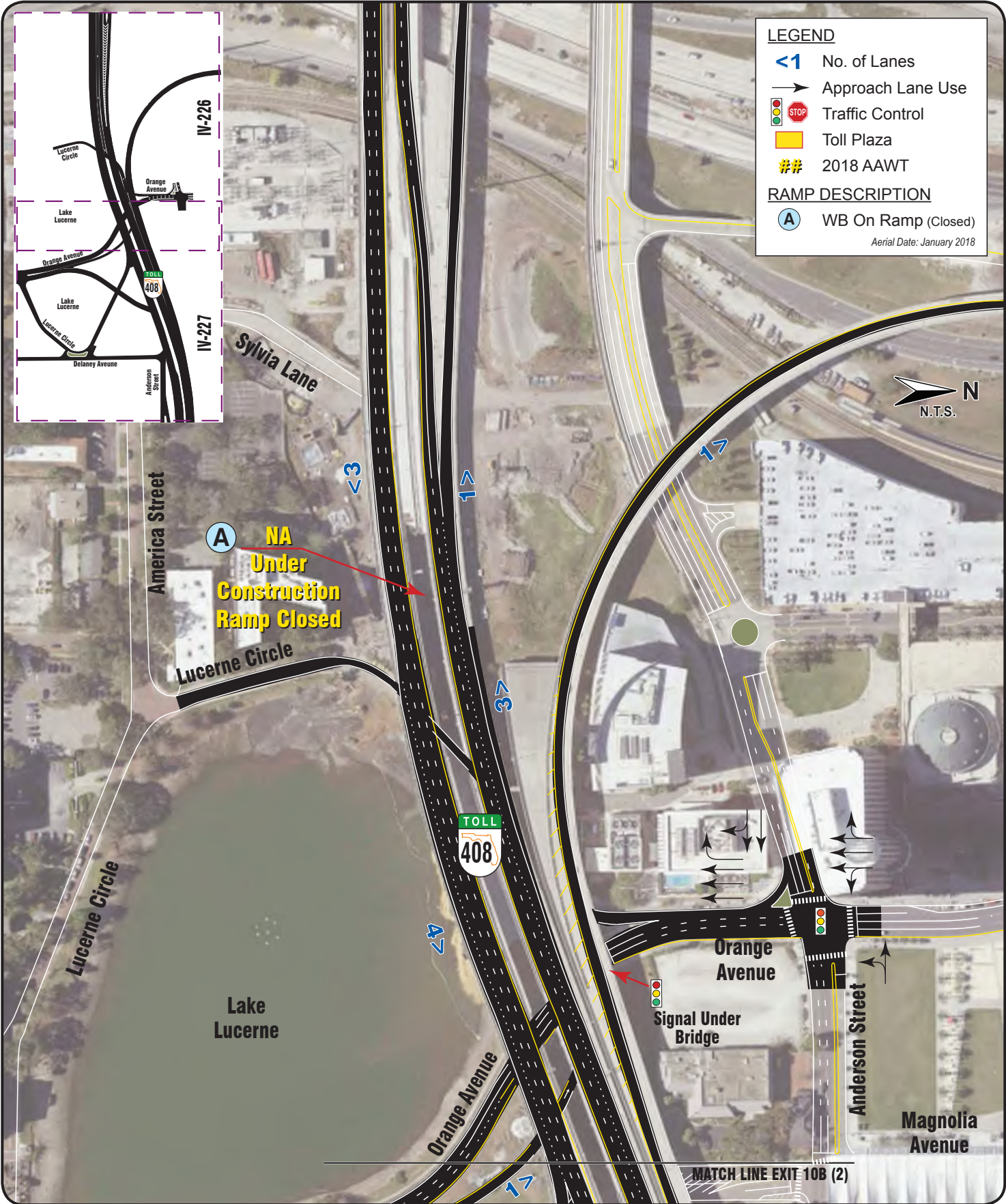

SR 408 (EAST-WEST EXPRESSWAY)
Exit 10A/B - Interstate 4

SECTION IV



LEGEND

-  No. of Lanes
-  Approach Lane Use
-  Traffic Control
-  Toll Plaza
-  2018 AAWT

RAMP DESCRIPTION

-  EB Off Ramp

Aerial Date: January 2018

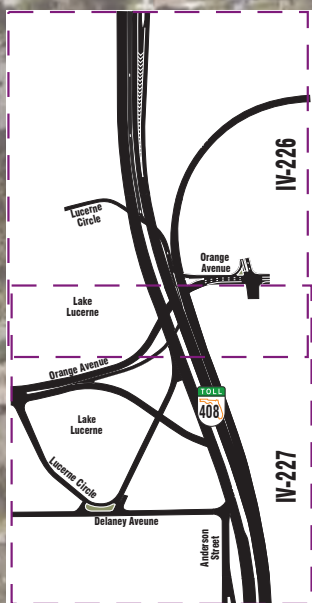
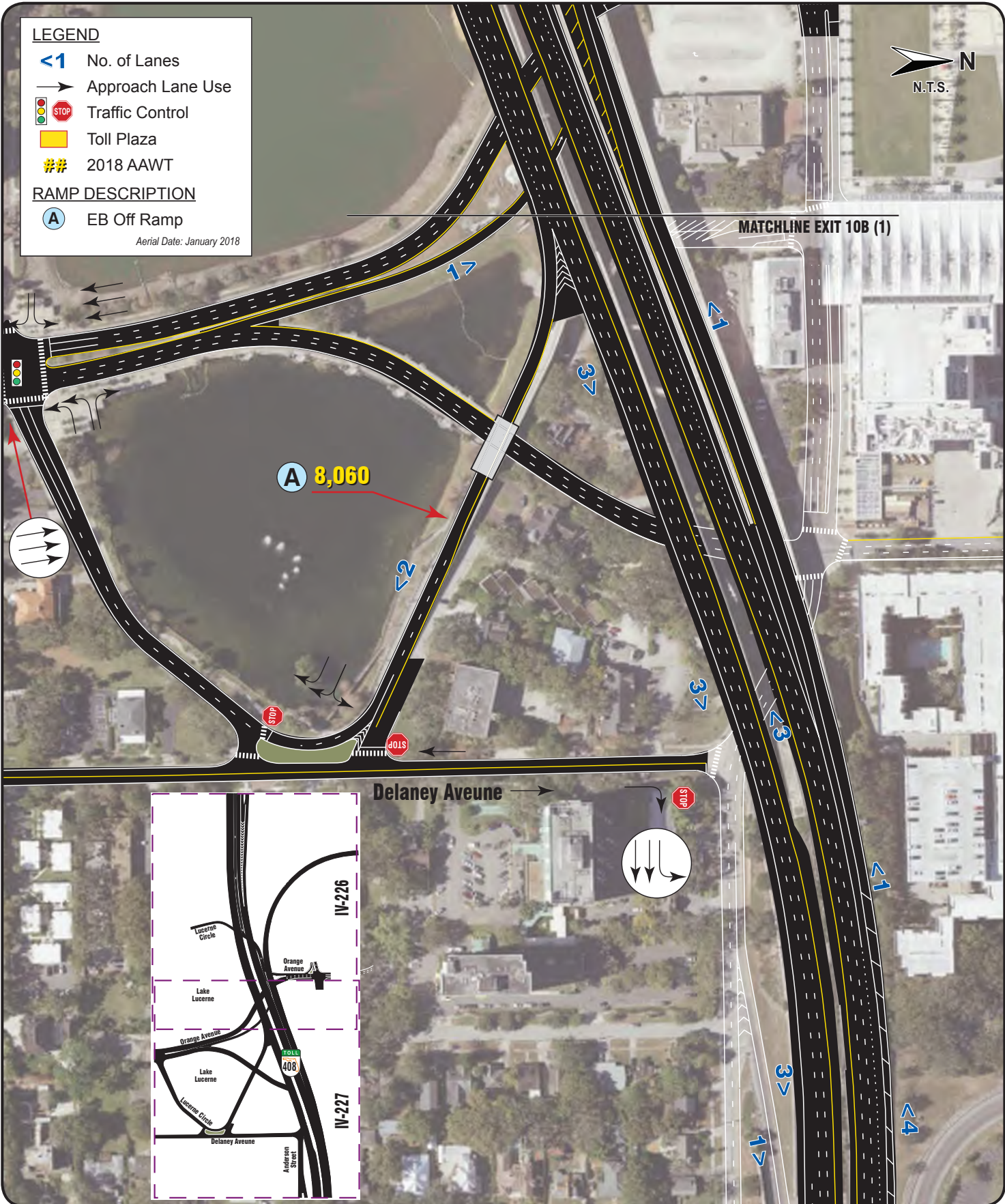

Delaney Avenue →



**SR 408 (EAST-WEST EXPRESSWAY)
Exit 10C - Orange Avenue (2)**

SECTION IV

227

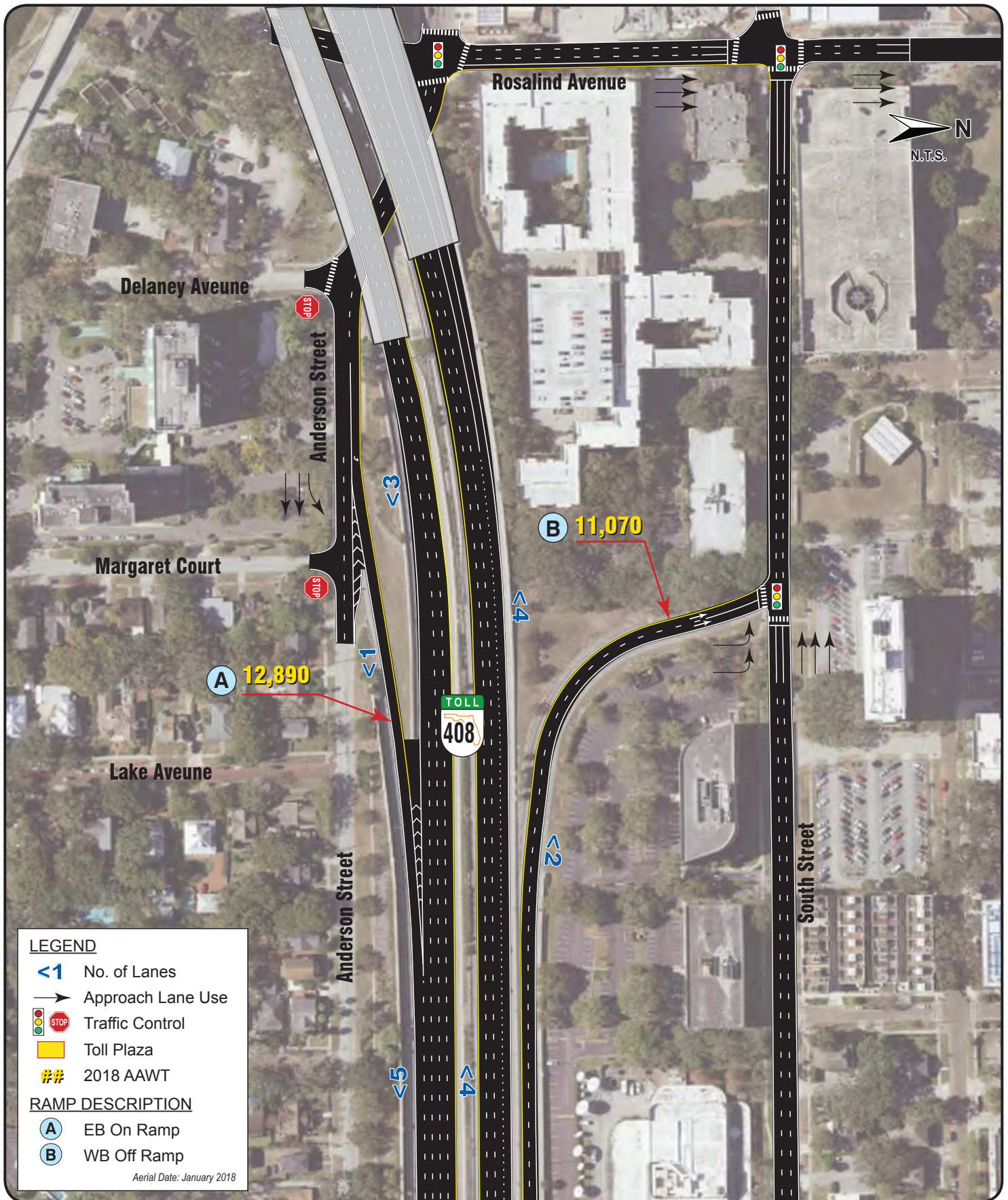

SR 408 (EAST-WEST EXPRESSWAY)
Exit 11A - Rosalind Avenue

SECTION IV

LEGEND

- <1 No. of Lanes
- Approach Lane Use
- Traffic Control
- Toll Plaza
- ## 2018 AAWT

RAMP DESCRIPTION

- (A)** EB Off Ramp
- (B)** WB Off Ramp
- (C)** EB On Ramp

Aerial Date: January 2018

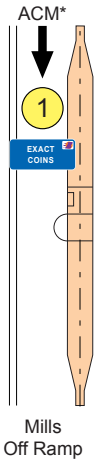

Reports to Conway Mainline Toll Plaza

Ramp Toll: E-PASS \$0.55 - CASH \$0.75

*Changable Message Sign (CMS)
 Note: All CMS can display three messages:
 EXACT COINS, CHANGE RECEIPTS, E-PASS ONLY

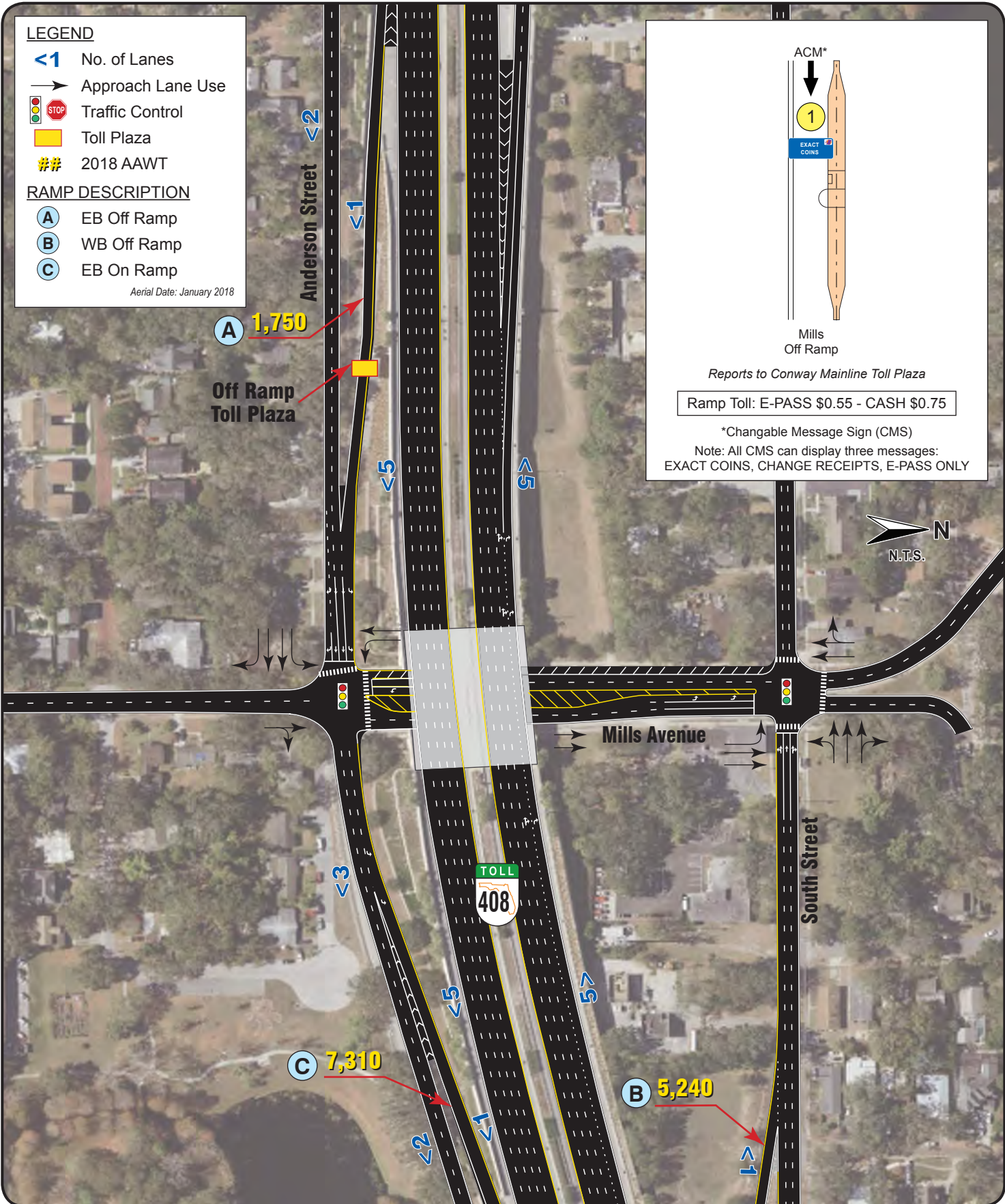

LEGEND

- <1 No. of Lanes
- ➔ Approach Lane Use
- Traffic Control
- Toll Plaza
- ## 2018 AAWT

RAMP DESCRIPTION

- EB Off Ramp
- WB On Ramp

Aerial Date: January 2018

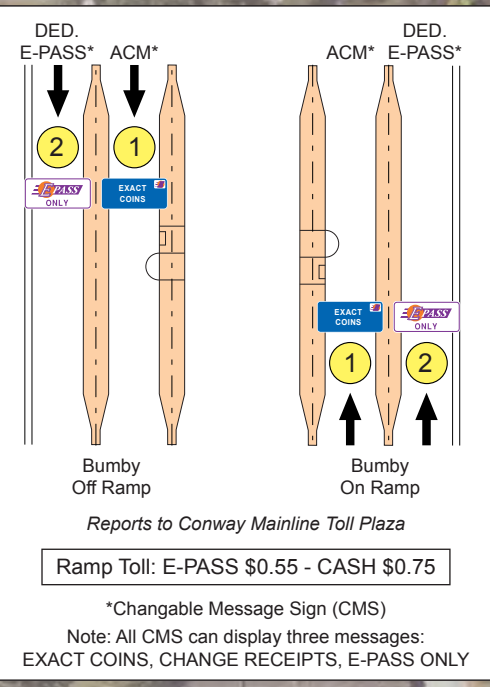
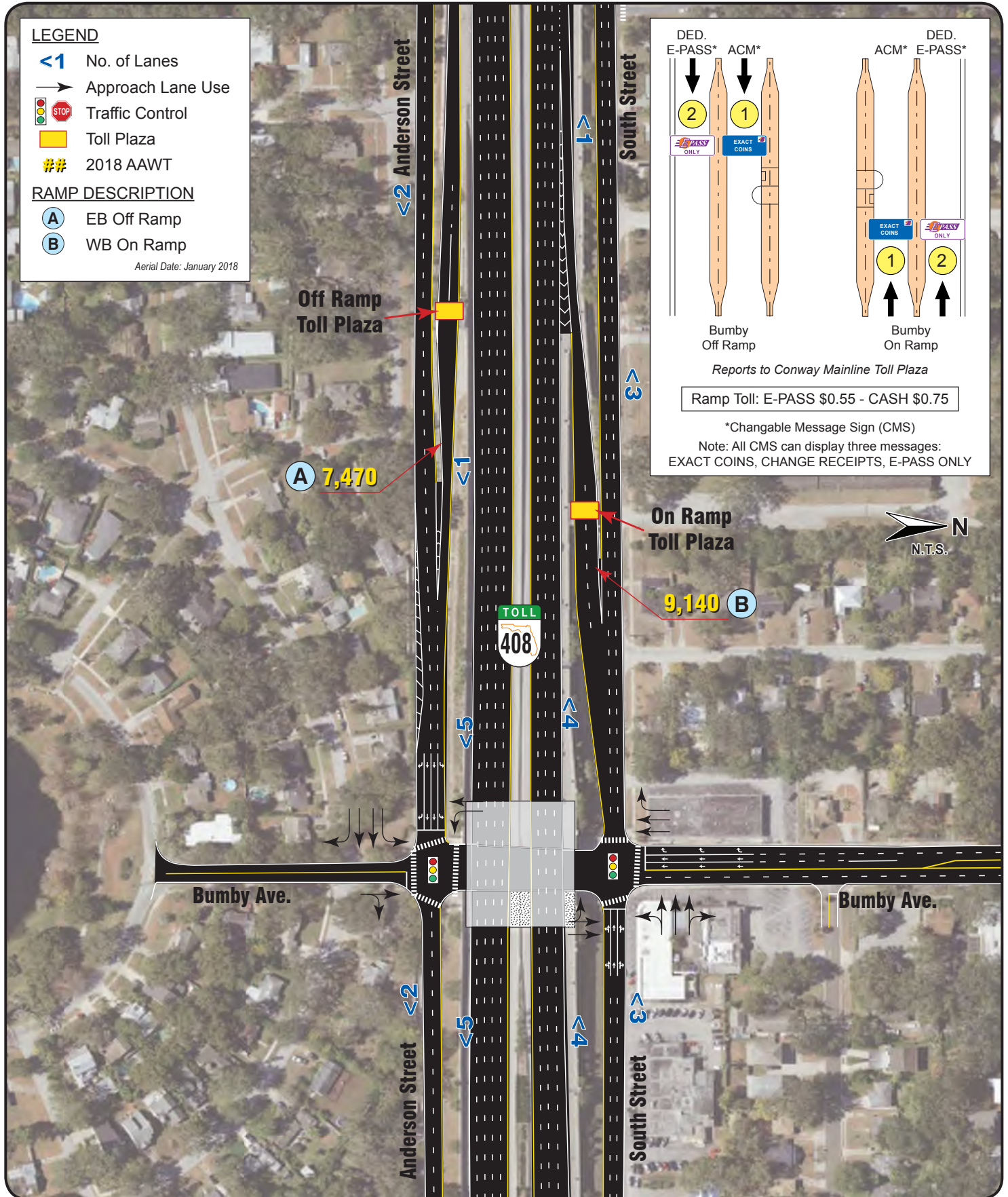

A 7,470

On Ramp Toll Plaza
9,140 B



SR 408 (EAST-WEST EXPRESSWAY)
Exit 12A - Bumby Avenue

LEGEND

- <1 No. of Lanes
- Approach Lane Use
- Traffic Control
- Toll Plaza
- ## 2018 AAWT

RAMP DESCRIPTION

- (A) WB Off Ramp
- (B) EB On Ramp

Aerial Date: January 2018

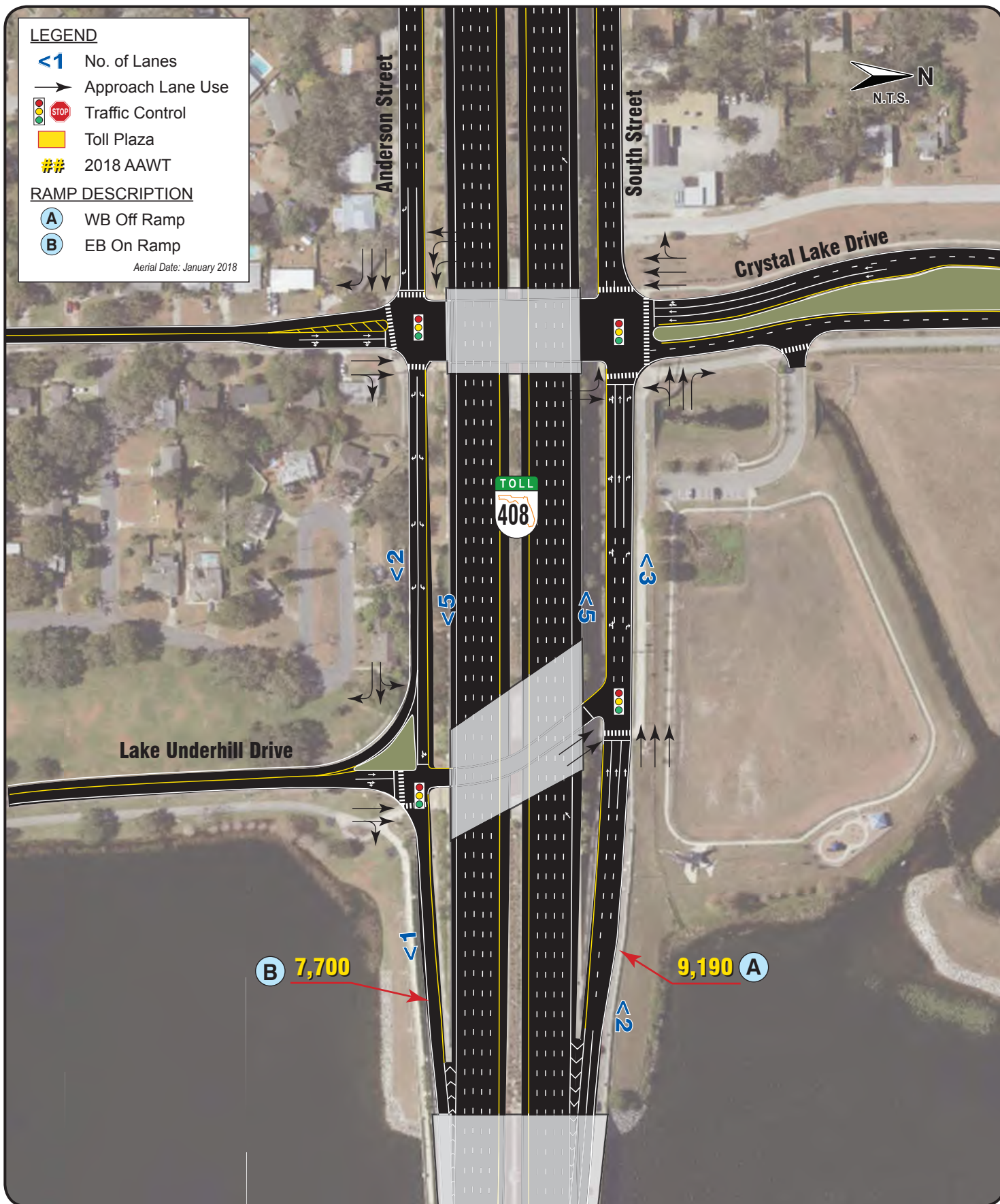

**SR 408 (EAST-WEST EXPRESSWAY)
Exit 12B - Crystal Lake Drive**

SECTION IV

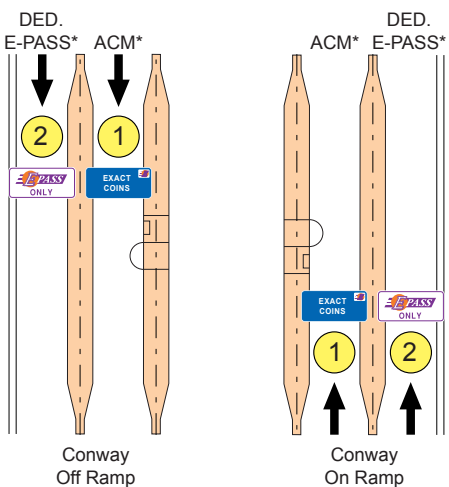

Reports to Conway Mainline Toll Plaza

Ramp Toll: E-PASS \$0.82 - CASH \$1.00

*Changable Message Sign (CMS)

Note: All CMS can display three messages:
 EXACT COINS, CHANGE RECEIPTS, E-PASS ONLY

LEGEND

- <1 No. of Lanes
- ➔ Approach Lane Use
- 🚦 Traffic Control
- 🟡 Toll Plaza
- ## 2018 AAWT

RAMP DESCRIPTION

- (A) WB On Ramp
- (B) EB Off Ramp

Aerial Date: January 2018



SR 408 (EAST-WEST EXPRESSWAY)
Exit 13 - Conway Road

SECTION IV

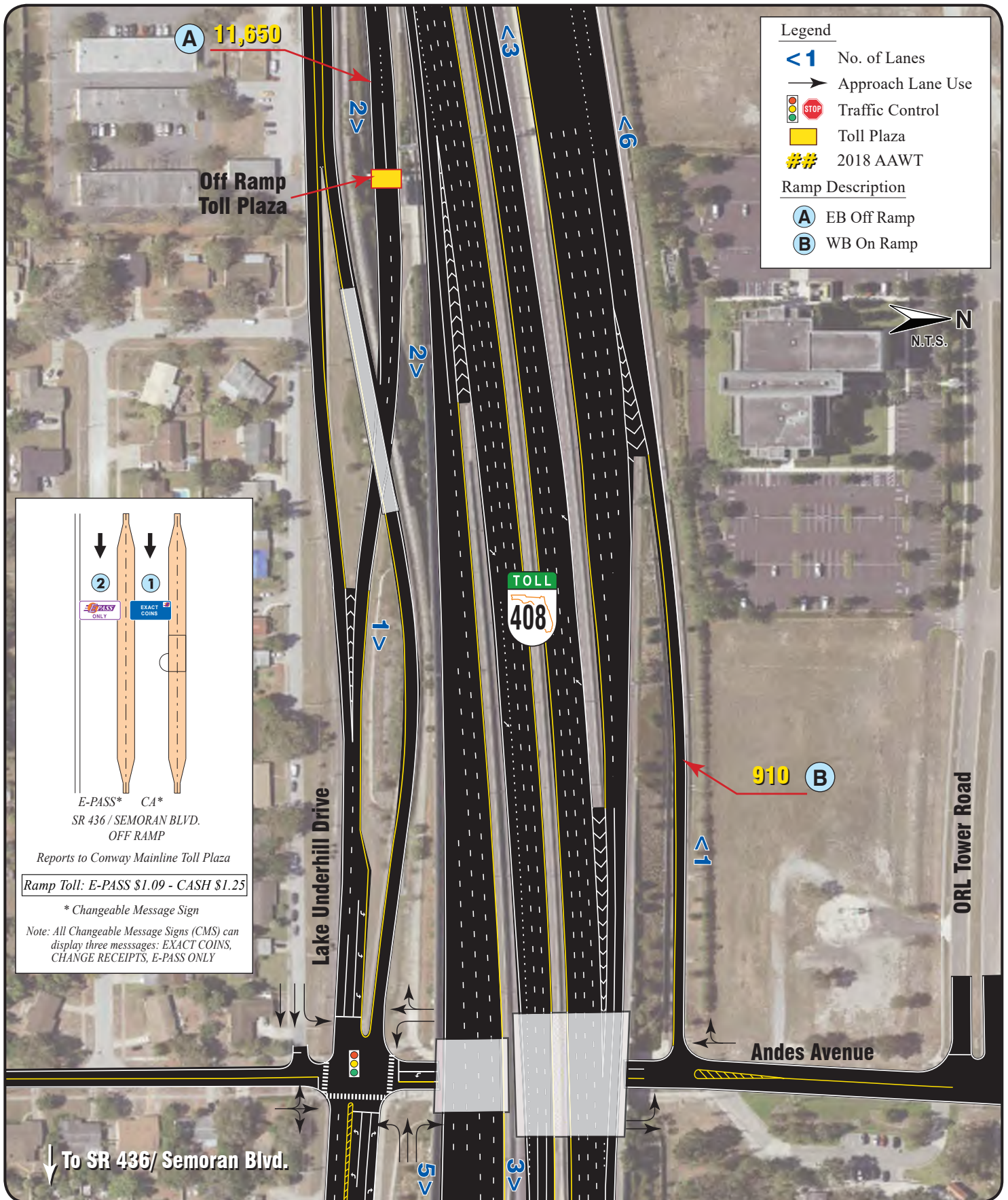

E-PASS* CA*
 SR 436 / SEMORAN BLVD.
 OFF RAMP





Reports to Conway Mainline Toll Plaza

Ramp Toll: E-PASS \$1.09 - CASH \$1.25



* Changeable Message Sign

Note: All Changeable Message Signs (CMS) can display three messages: EXACT COINS, CHANGE RECEIPTS, E-PASS ONLY

LEGEND

-  No. of Lanes
-  Approach Lane Use
-  Traffic Control
-  Toll Plaza
-  2018 AAWT

RAMP DESCRIPTION

-  WB On Ramp
-  WB On Loop Ramp
-  WB Off Ramp

Aerial Date: January 2018

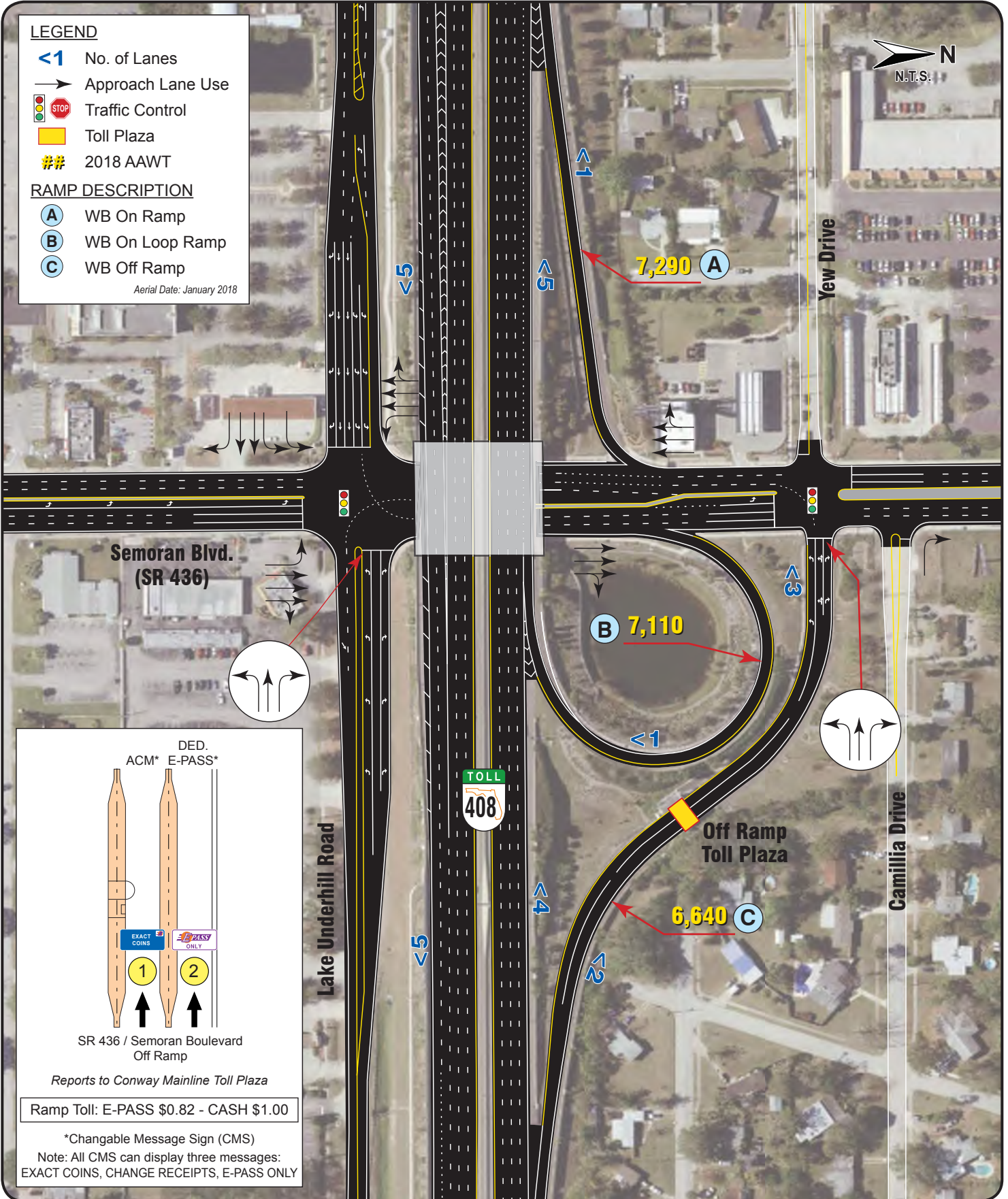

**Semoran Blvd.
(SR 436)**



DED.
ACM* E-PASS*

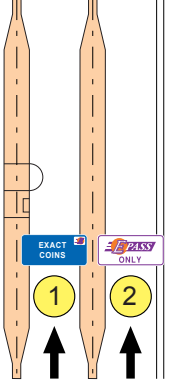

SR 436 / Semoran Boulevard
Off Ramp

Reports to Conway Mainline Toll Plaza

Ramp Toll: E-PASS \$0.82 - CASH \$1.00

*Changable Message Sign (CMS)

Note: All CMS can display three messages:
EXACT COINS, CHANGE RECEIPTS, E-PASS ONLY



**SR 408 (EAST-WEST EXPRESSWAY)
Exit 14 - Semoran Boulevard (SR 436)**

SECTION IV

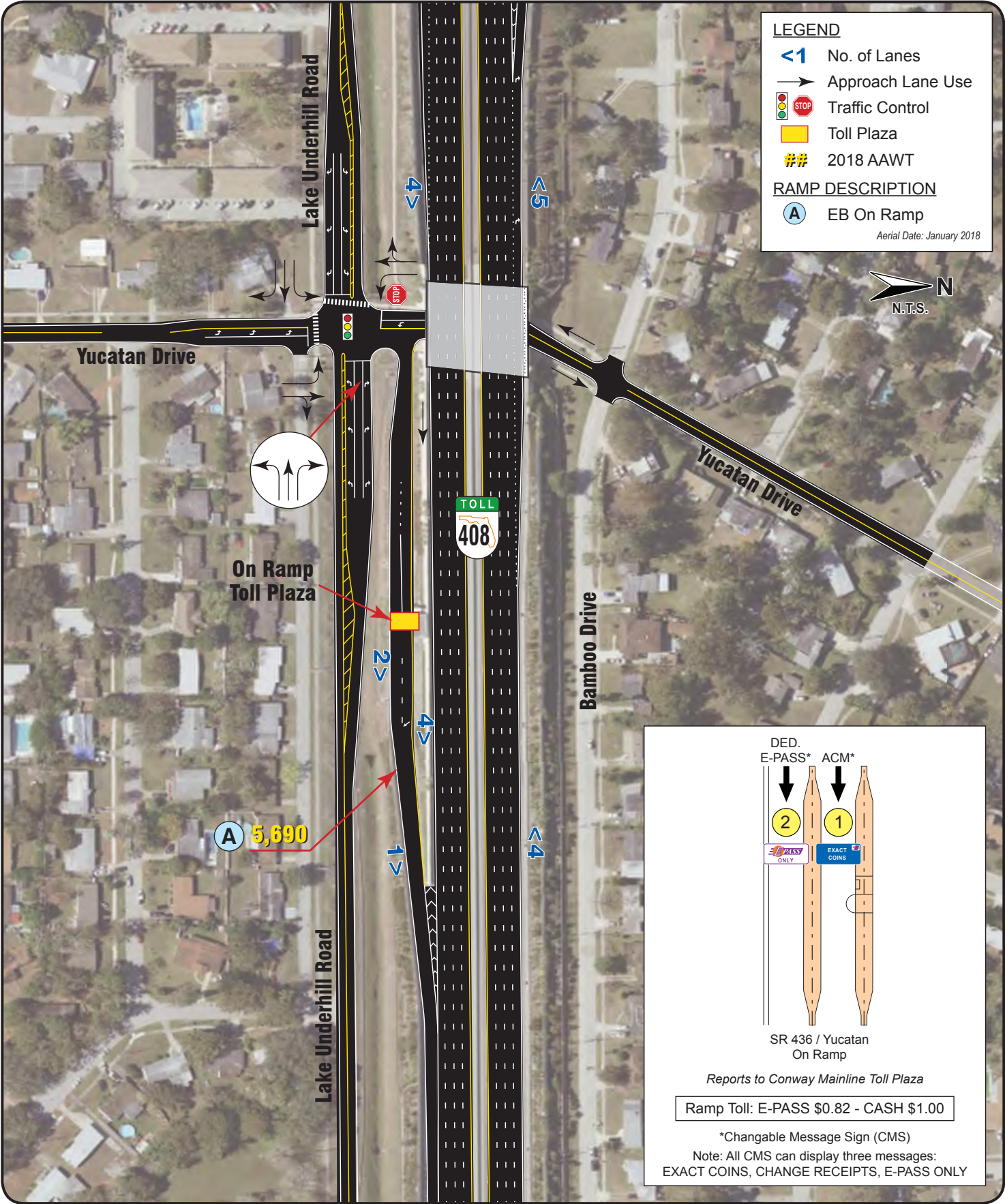



LEGEND

- <1> No. of Lanes
- Approach Lane Use
- 🚦 Traffic Control
- 🟡 Toll Plaza
- ## 2018 AAWT

RAMP DESCRIPTION

(A)	EB Off Ramp
(B)	WB On Ramp
(C)	EB On Ramp
(D)	WB Off Ramp

Aerial Date: January 2018



SR 408 (EAST-WEST EXPRESSWAY)
Exit 16 - Goldenrod Road (SR 551)

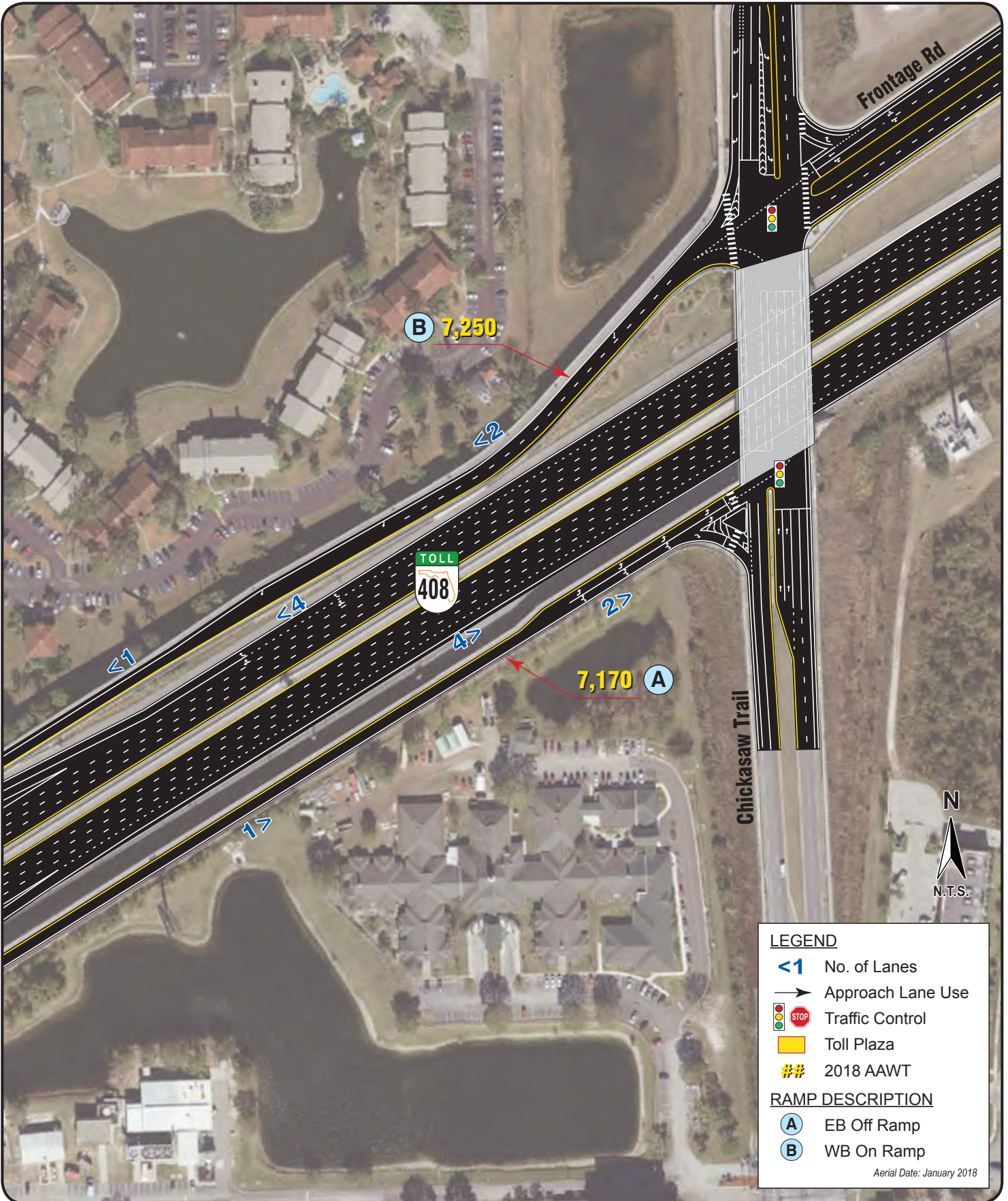

LEGEND

- <1 No. of Lanes
- Approach Lane Use
- Traffic Control
- Toll Plaza
- ## 2018 AAWT

RAMP DESCRIPTION

- (A) EB Off Ramp
- (B) WB On Ramp

Aerial Date: January 2018



**SR 408 (EAST-WEST EXPRESSWAY)
Exit 17 - Chickasaw Trail**

SECTION IV

237

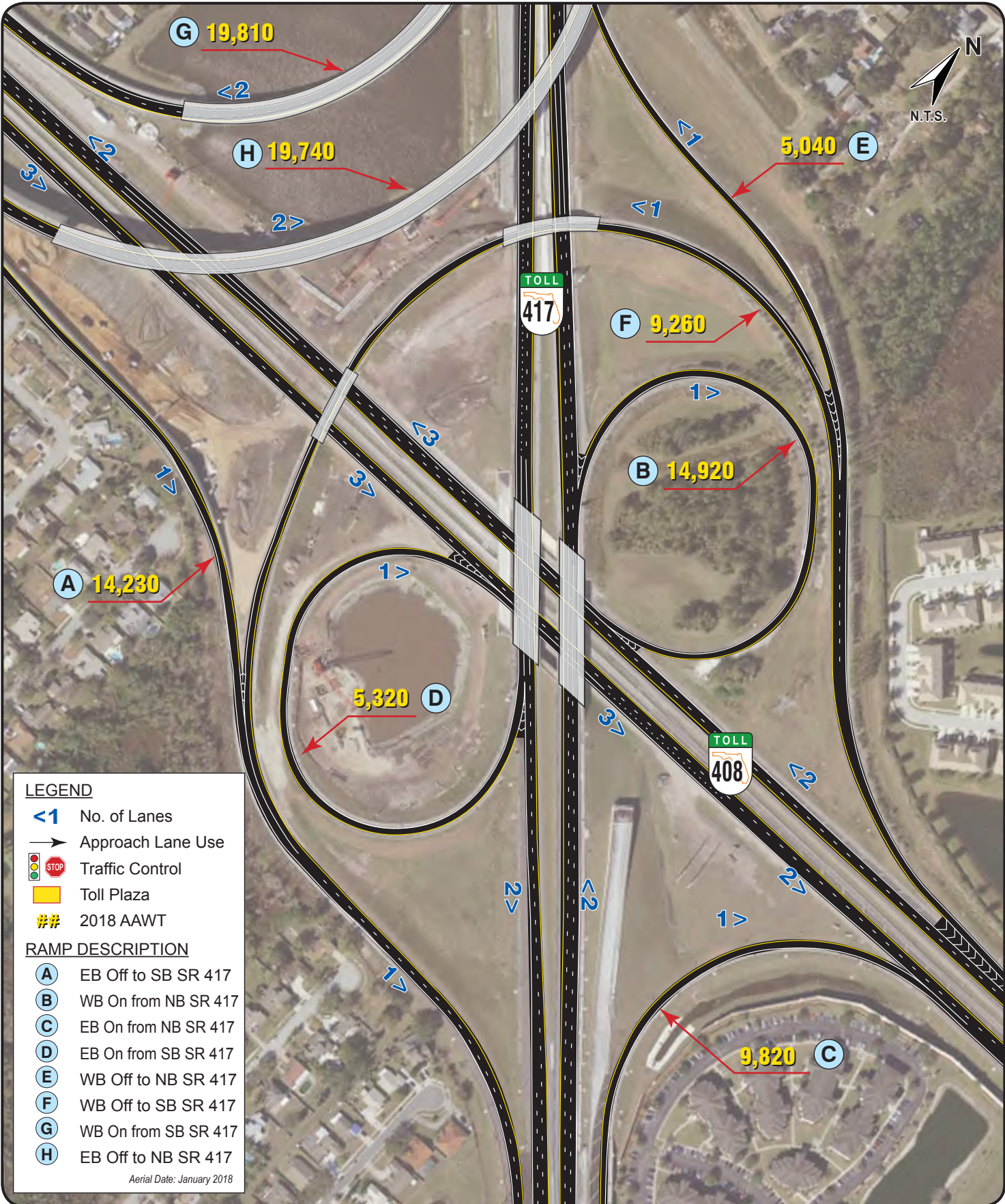

LEGEND

- <1 No. of Lanes
- ➔ Approach Lane Use
- Traffic Control
- Toll Plaza
- ## 2018 AAWT

RAMP DESCRIPTION

- A** EB Off to SB SR 417
- B** WB On from NB SR 417
- C** EB On from NB SR 417
- D** EB On from SB SR 417
- E** WB Off to NB SR 417
- F** WB Off to SB SR 417
- G** WB On from SB SR 417
- H** EB Off to NB SR 417

Aerial Date: January 2018



SR 408 (EAST-WEST EXPRESSWAY)
Exit 18 - Central Florida GreenWay (SR 417)

SECTION IV



LEGEND

- <1 No. of Lanes
- Approach Lane Use
- Traffic Control
- Toll Plaza
- ## 2018 AAWT

RAMP DESCRIPTION

- A** EB Off Ramp
- B** WB On Ramp
- C** EB On Ramp
- D** WB Off Ramp

Aerial Date: January 2018

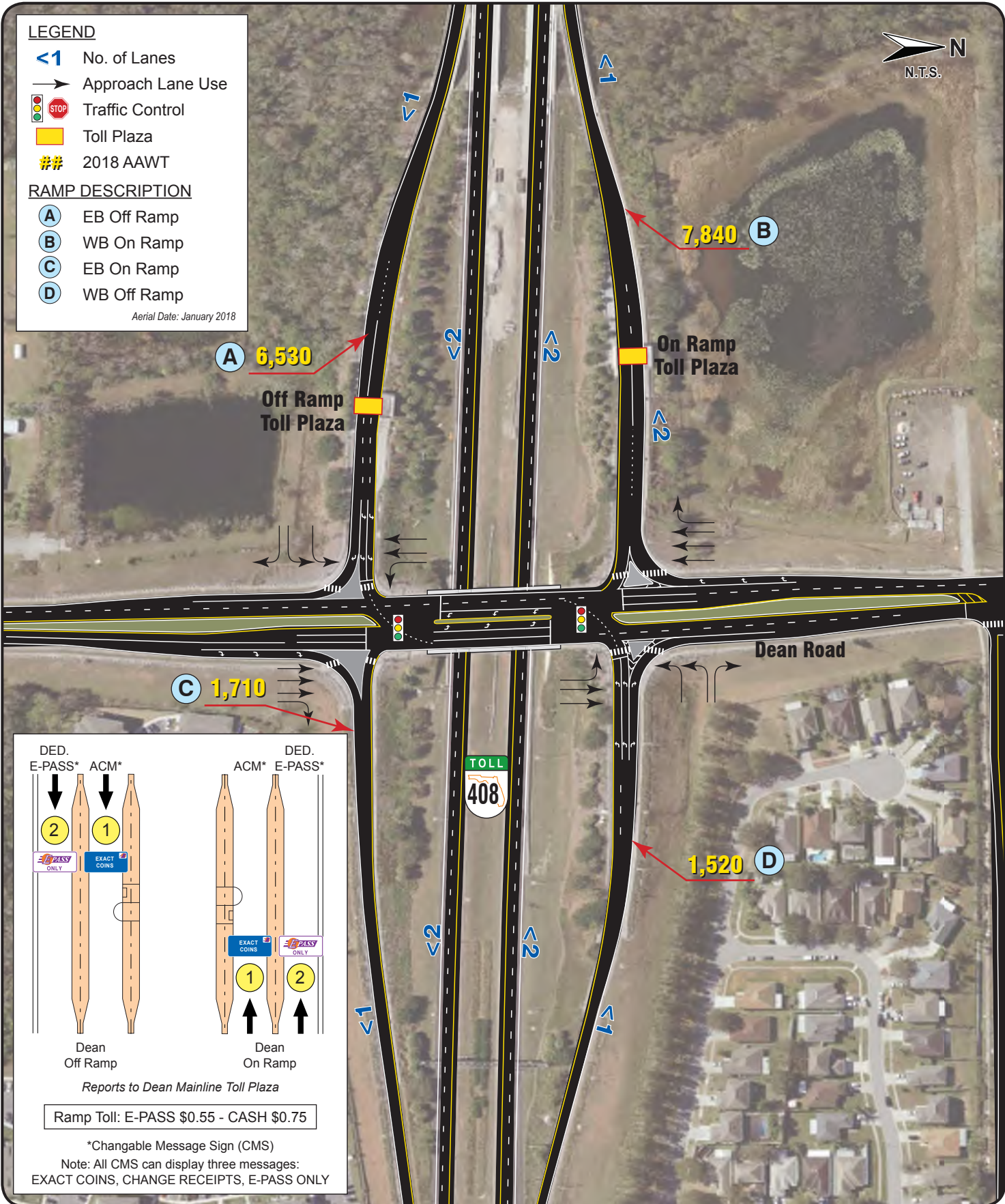

DED. E-PASS*	ACM*	DED. ACM*	E-PASS*
Dean Off Ramp	Dean On Ramp		
Reports to Dean Mainline Toll Plaza			
Ramp Toll: E-PASS \$0.55 - CASH \$0.75			
*Changable Message Sign (CMS)			
Note: All CMS can display three messages: EXACT COINS, CHANGE RECEIPTS, E-PASS ONLY			



SR 408 (EAST-WEST EXPRESSWAY)
Exit 19 - Dean Road

SECTION IV

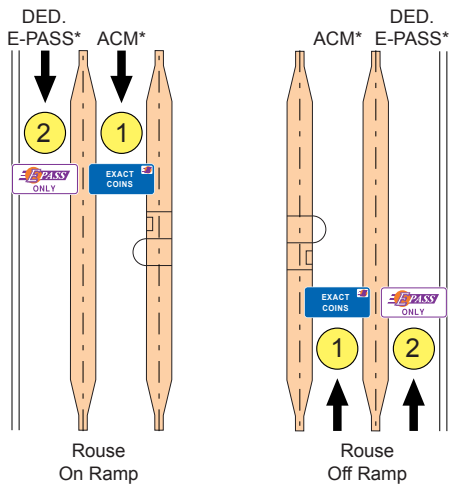

Reports to Dean Mainline Toll Plaza

Ramp Toll: E-PASS \$0.55 - CASH \$0.75

*Changable Message Sign (CMS)

Note: All CMS can display three messages: EXACT COINS, CHANGE RECEIPTS, E-PASS ONLY

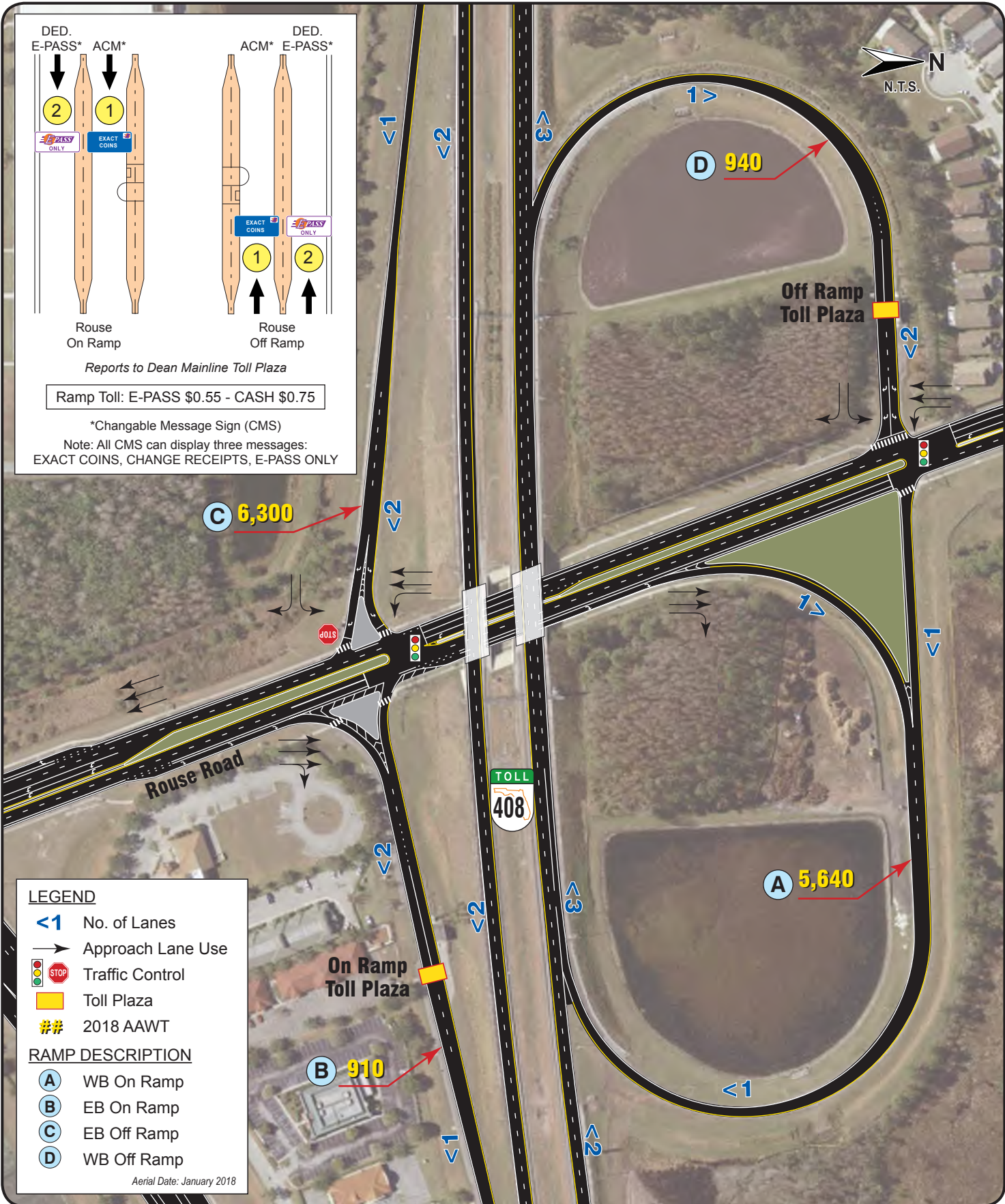

LEGEND

- <1 No. of Lanes
- Approach Lane Use
- ⬇️ Traffic Control
- 🟡 Toll Plaza
- ## 2018 AAWT

RAMP DESCRIPTION

- A WB On Ramp
- B EB On Ramp
- C EB Off Ramp
- D WB Off Ramp

Aerial Date: January 2018



**SR 408 (EAST-WEST EXPRESSWAY)
Exit 20 - Rouse Road**

SECTION IV

240



LEGEND

- <1 No. of Lanes
- Approach Lane Use
- 🚦 STOP Traffic Control
- 🟡 Toll Plaza
- ## 2018 AAWT

RAMP DESCRIPTION

- Ⓐ EB Off Ramp
- Ⓑ WB On Ramp

Aerial Date: January 2018

N
N.T.S.

Ⓐ 14,590

15,560 Ⓑ

TOLL
408

Alafaya Trail

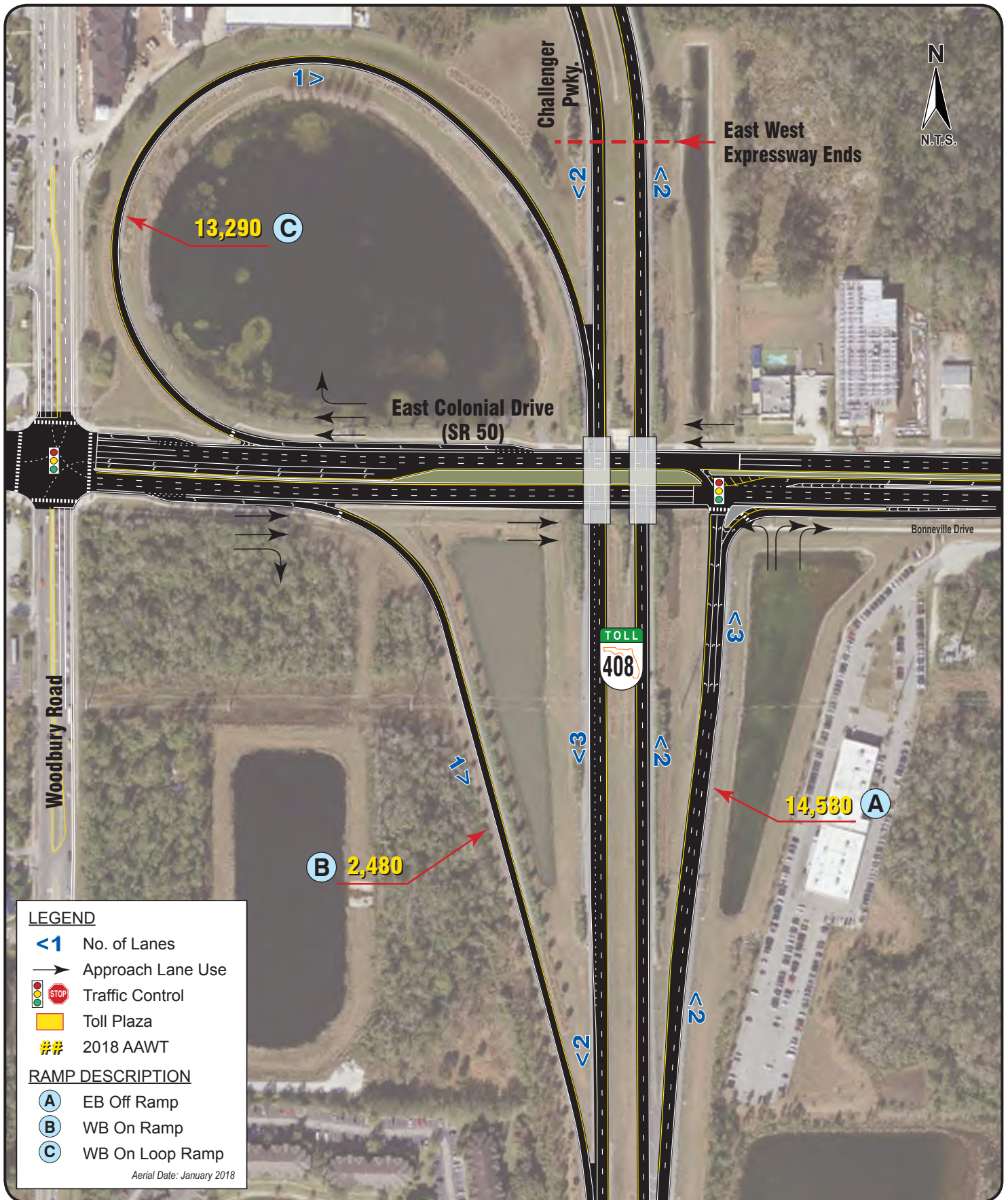

**SR 408 (EAST-WEST EXPRESSWAY)
Exit 23 - East Colonial Drive (SR 50)**

SECTION IV

Beachline Expressway



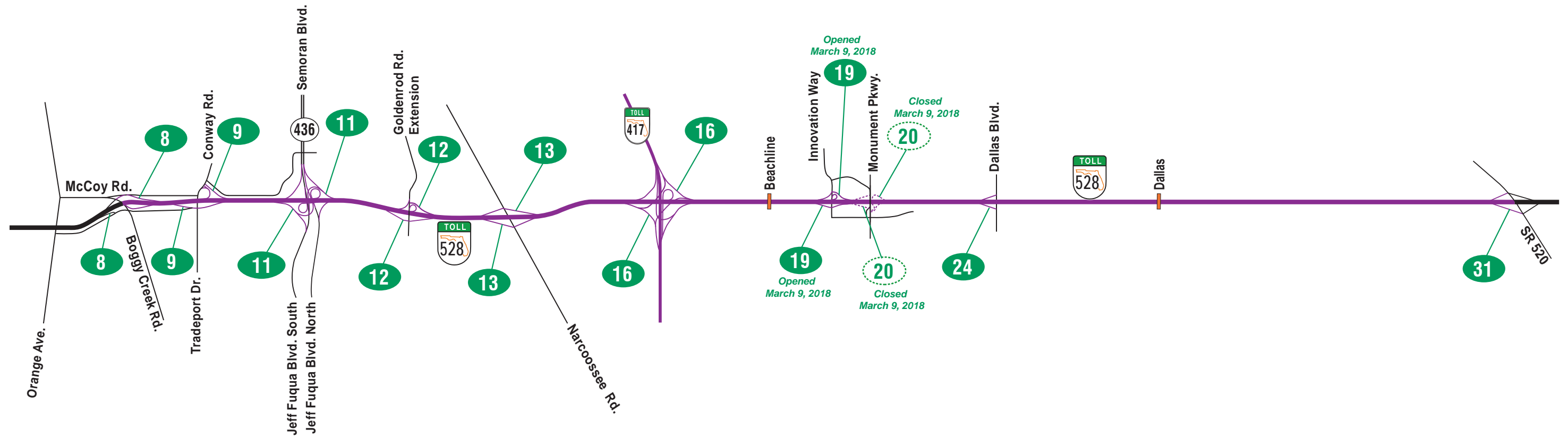

LEGEND

- Exit Number
- Existing SR 528
- Mainline Toll Plaza



SR 528 - BEACHLINE EXPRESSWAY
Exit Numbers

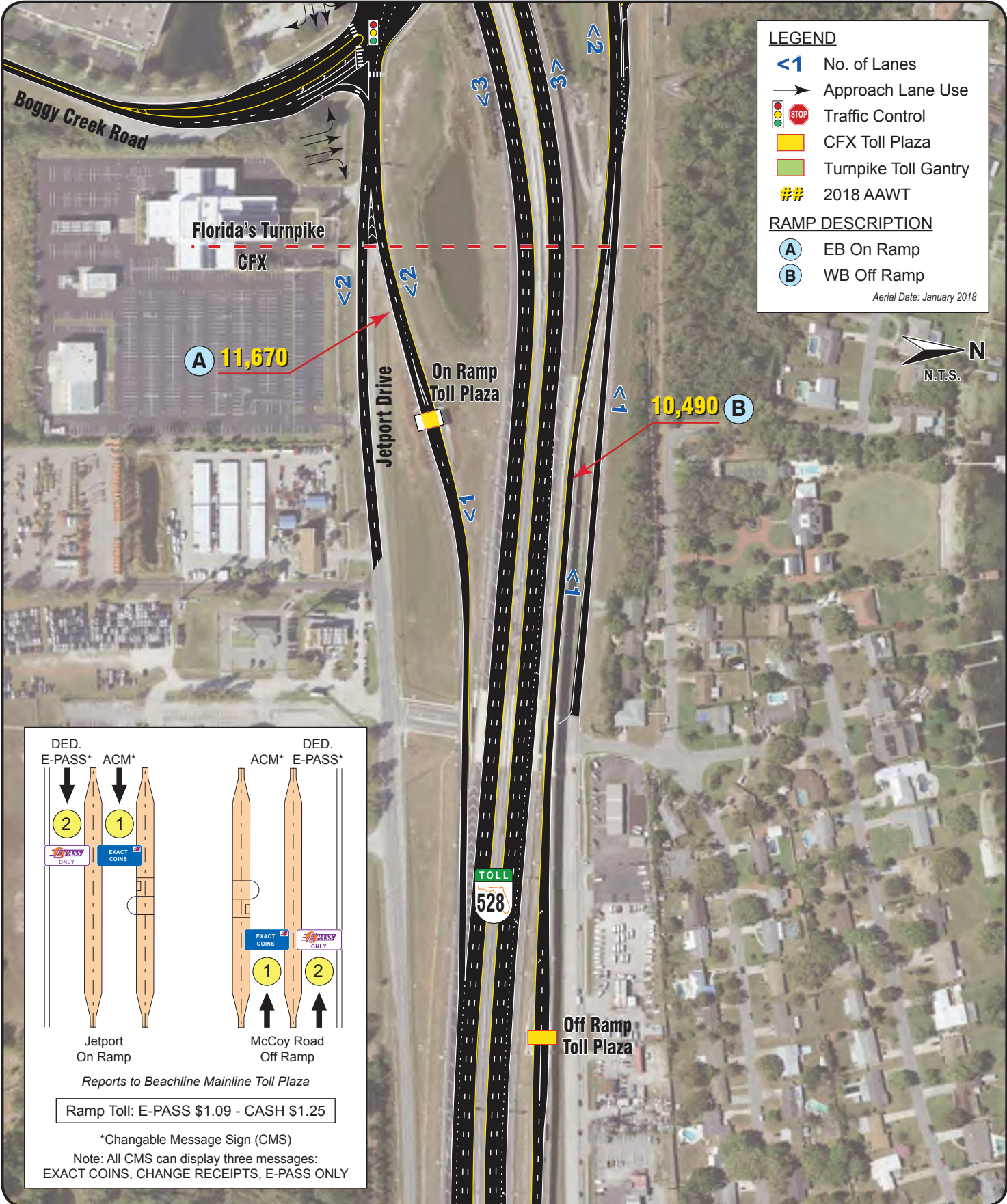

LEGEND

- <1> No. of Lanes
- Approach Lane Use
- 🚦 STOP Traffic Control
- 🟡 CFX Toll Plaza
- 🟢 Turnpike Toll Gantry
- ## 2018 AAWT

RAMP DESCRIPTION

- (A) EB On Ramp
- (B) WB Off Ramp

Aerial Date: January 2018



DED. E-PASS*	ACM*	DED. ACM*	E-PASS*
2	1	1	2
EXACT COINS ONLY	EXACT COINS	EXACT COINS	EXACT COINS ONLY
Jetport On Ramp		McCoy Road Off Ramp	
Reports to Beachline Mainline Toll Plaza			
Ramp Toll: E-PASS \$1.09 - CASH \$1.25			
*Changable Message Sign (CMS)			
Note: All CMS can display three messages: EXACT COINS, CHANGE RECEIPTS, E-PASS ONLY			



SR 528 (BEACHLINE EXPRESSWAY)
Exit 8 - Boggy Creek Road

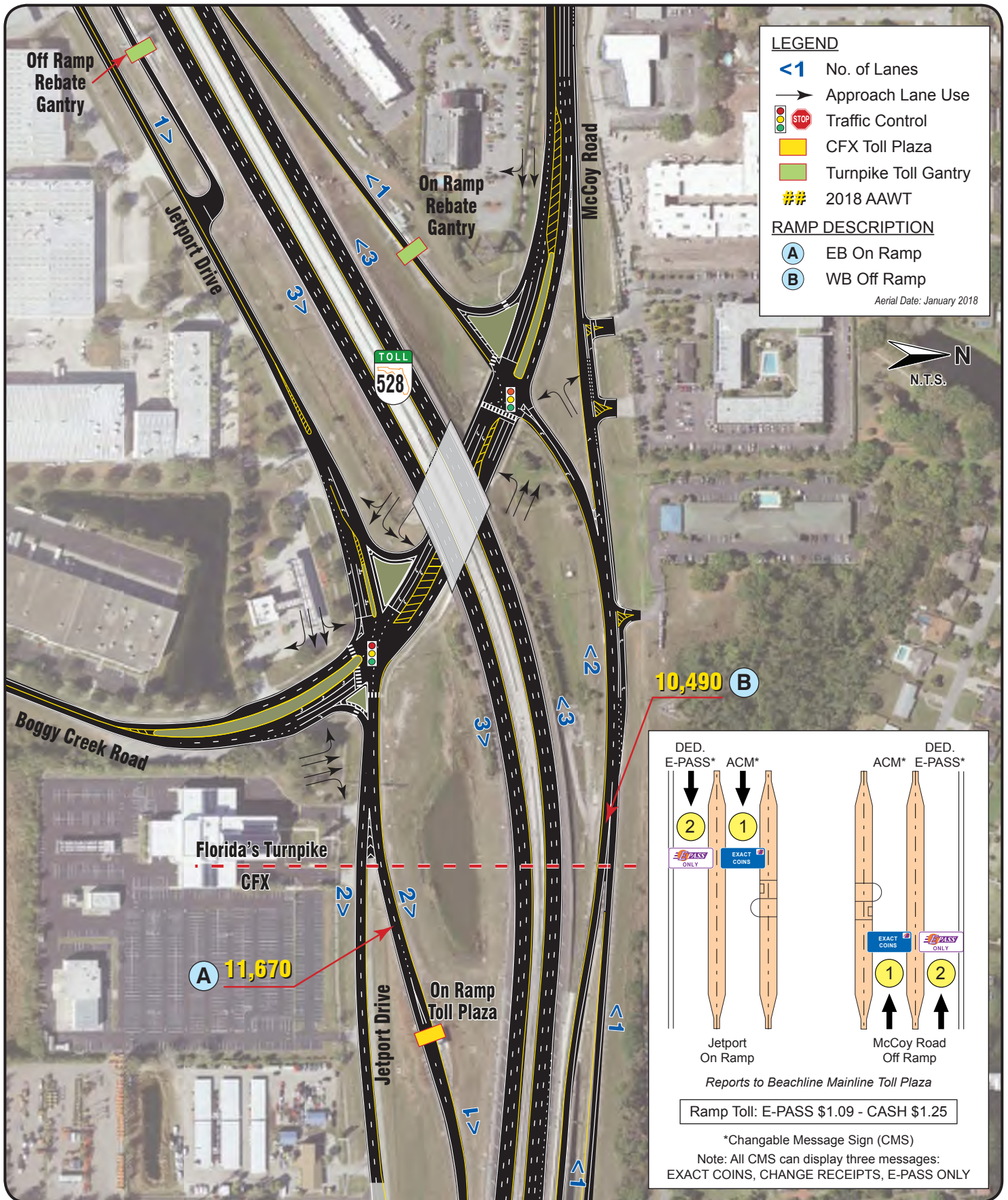

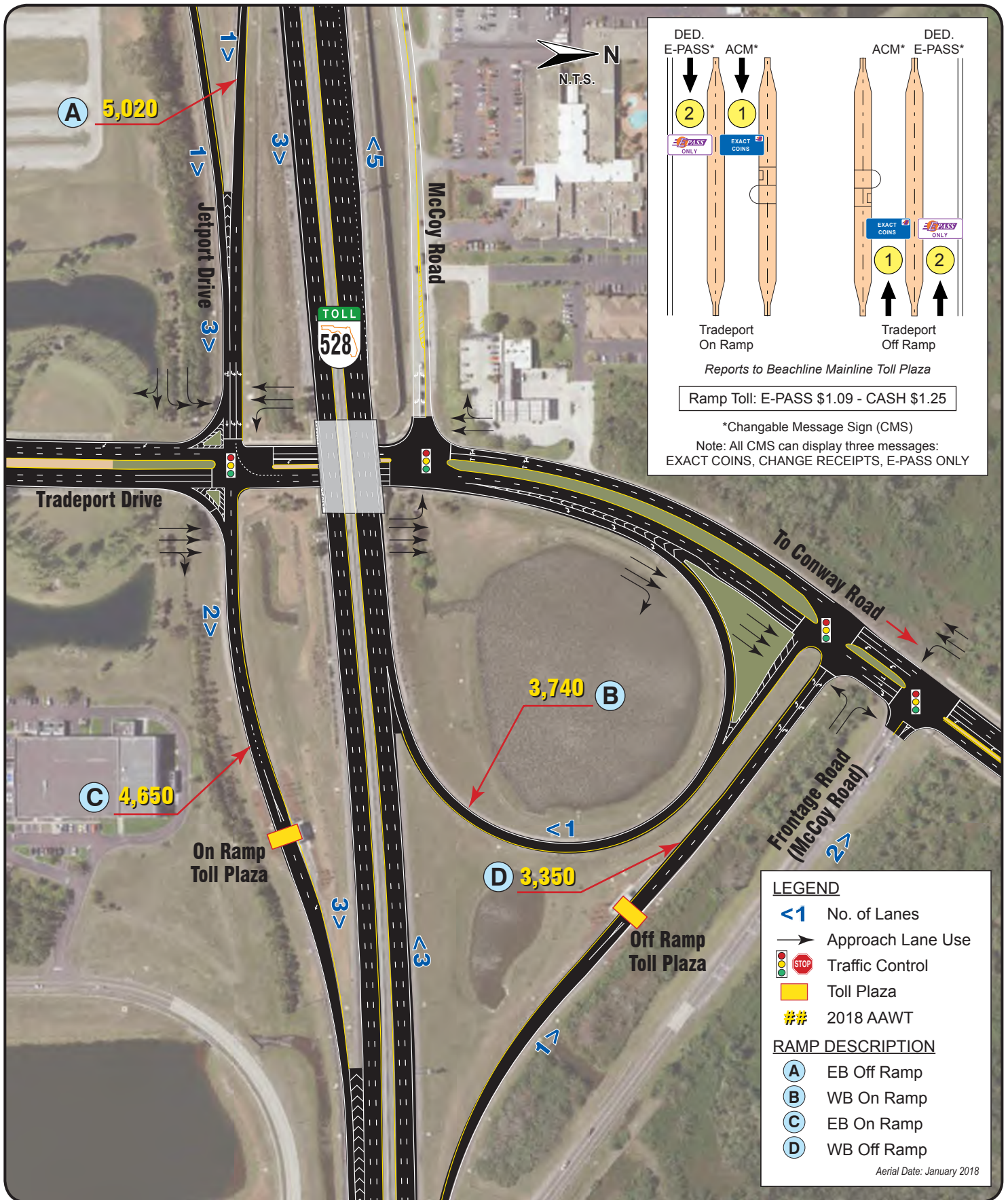

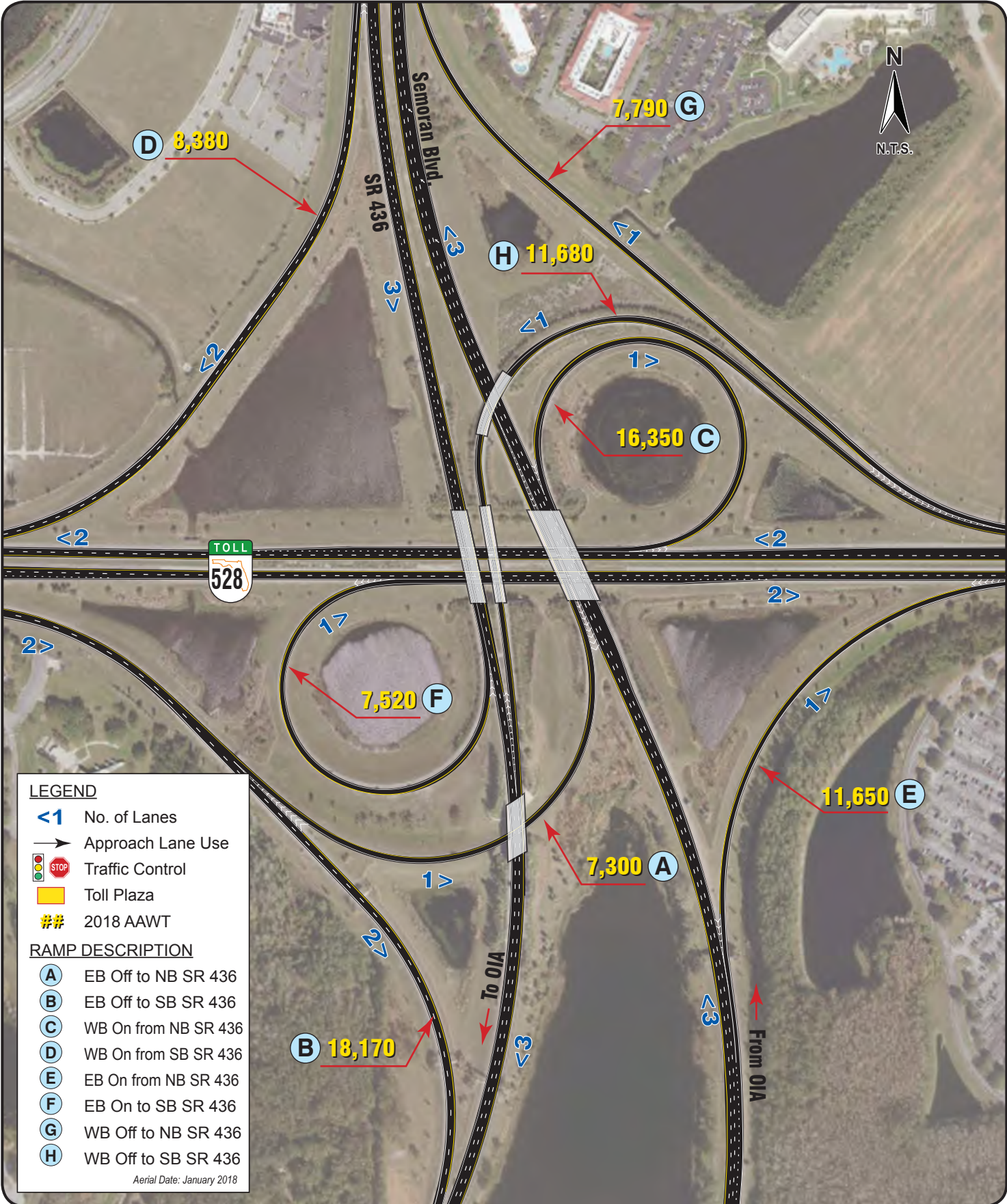



**SR 528 (BEACHLINE EXPRESSWAY)
Exit 11 - Semoran Boulevard (SR 436)**

SECTION IV



LEGEND

- <1** No. of Lanes
- Approach Lane Use
-  **STOP** Traffic Control
-  Toll Plaza
- ##** 2018 AAWT

RAMP DESCRIPTION

- (A)** EB Off Ramp
- (B)** WB On Ramp
- (C)** EB On Ramp
- (D)** WB Off Ramp

Aerial Date: January 2018

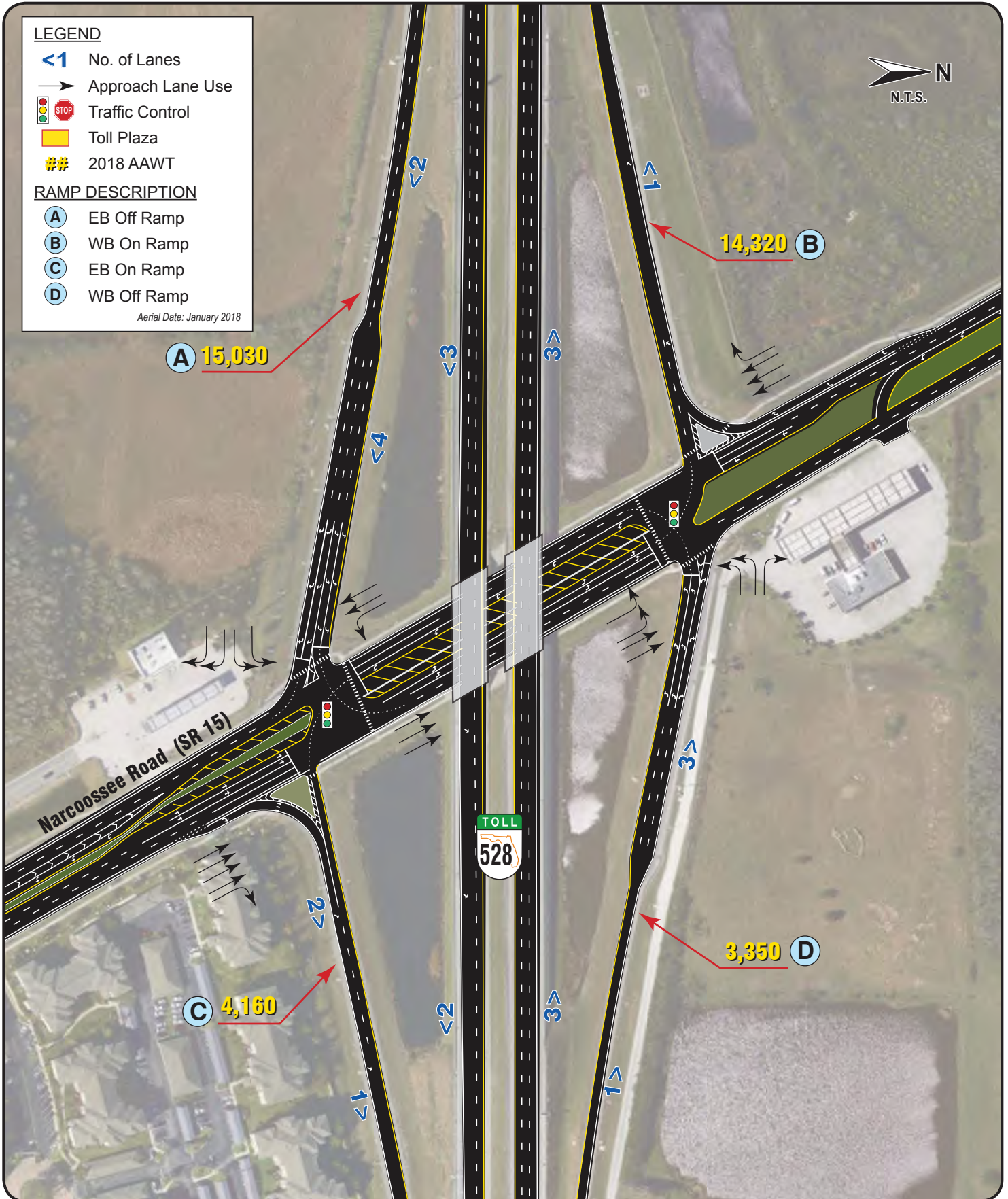

**SR 528 (BEACHLINE EXPRESSWAY)
Exit 13 - Narcoossee Road (SR 15)**

SECTION IV

250

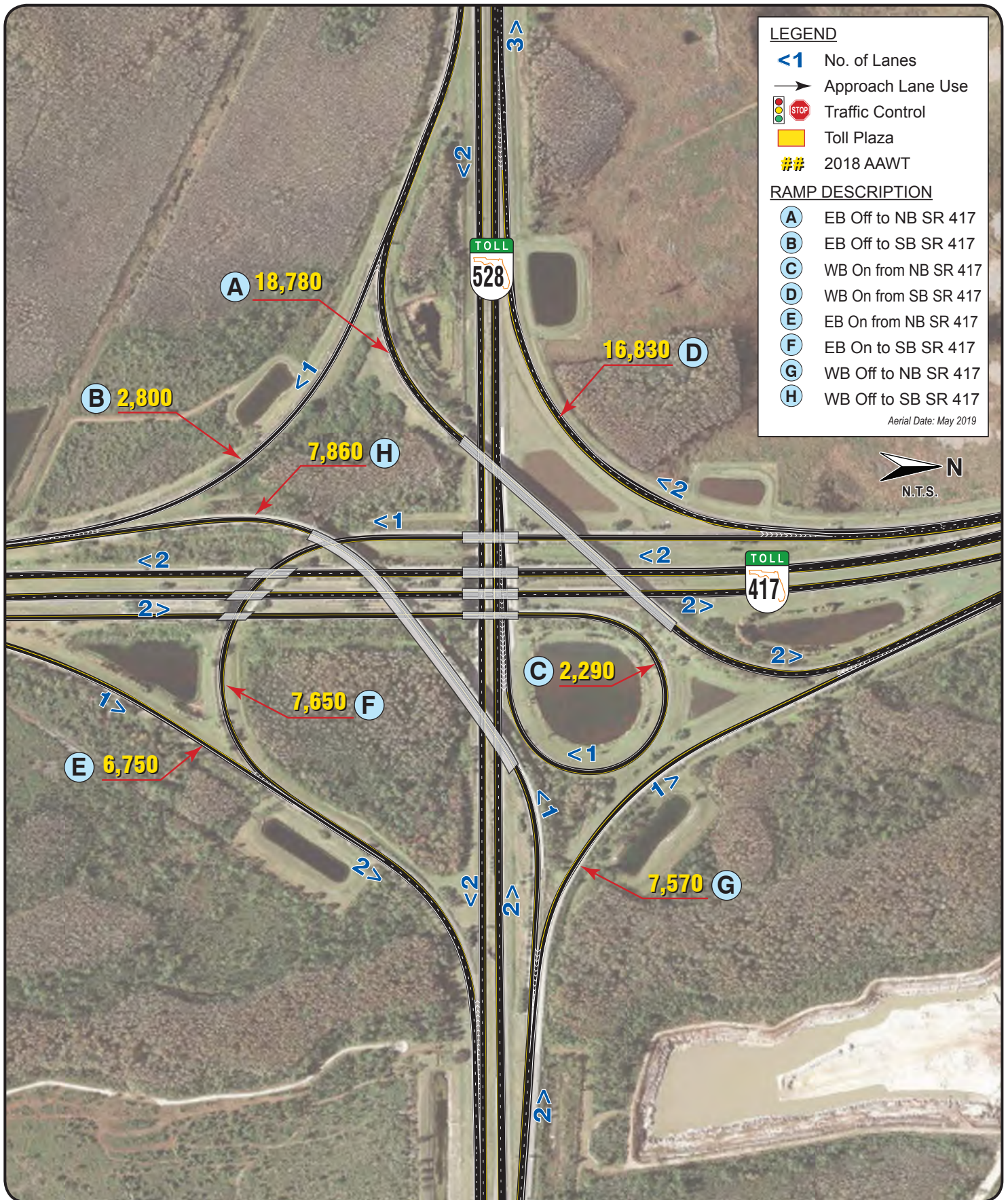

LEGEND

- <1 No. of Lanes
- Approach Lane Use
- STOP Traffic Control
- TOLL Plaza
- ## 2018 AAWT

RAMP DESCRIPTION

- (A) EB Off to NB SR 417
- (B) EB Off to SB SR 417
- (C) WB On from NB SR 417
- (D) WB On from SB SR 417
- (E) EB On from NB SR 417
- (F) EB On to SB SR 417
- (G) WB Off to NB SR 417
- (H) WB Off to SB SR 417

Aerial Date: May 2019



SR 528 (BEACHLINE EXPRESSWAY)
Exit 16 - Central Florida GreeneWay (SR 417)

LEGEND

- <1 No. of Lanes
- Approach Lane Use
- Traffic Control
- Toll Plaza
- ## 2018 AAWT

RAMP DESCRIPTION

- (A) EB Off Ramp
- (B) WB On Ramp
- (C) EB On Ramp
- (D) WB Off Ramp
- (E) WB On-Loop Ramp

Aerial Date: January 2018

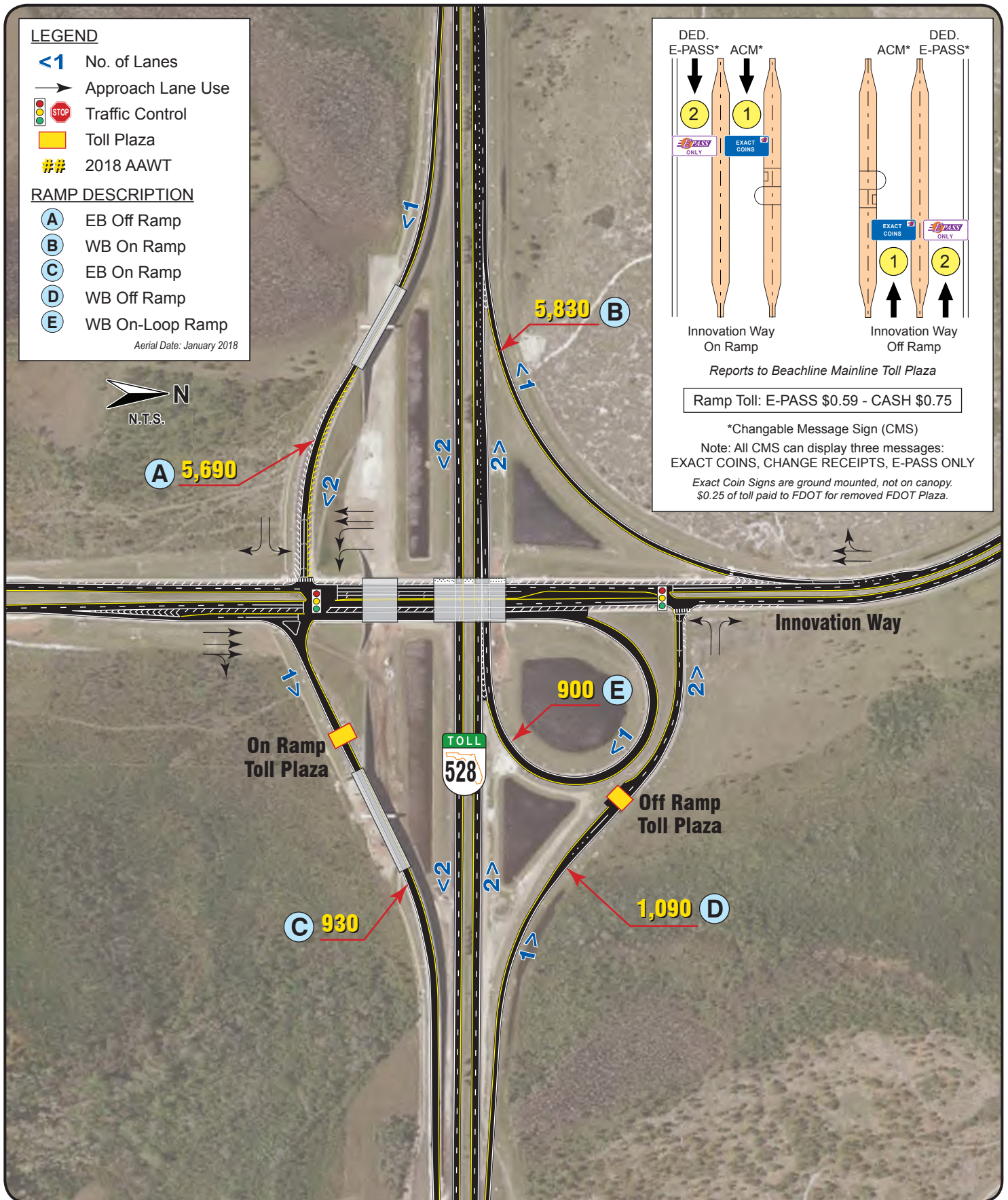

DED. E-PASS* ACM* DED. ACM* E-PASS*

Innovation Way On Ramp Innovation Way Off Ramp

Reports to Beachline Mainline Toll Plaza

Ramp Toll: E-PASS \$0.59 - CASH \$0.75

*Changable Message Sign (CMS)
 Note: All CMS can display three messages: EXACT COINS, CHANGE RECEIPTS, E-PASS ONLY
 Exact Coin Signs are ground mounted, not on canopy.
 \$0.25 of toll paid to FDOT for removed FDOT Plaza.



SR 528 (BEACHLINE EXPRESSWAY)
Exit 19 - Innovation Way

LEGEND

- <1 No. of Lanes
- Approach Lane Use
- Traffic Control
- Toll Plaza
- ## 2018 AAWT

RAMP DESCRIPTION

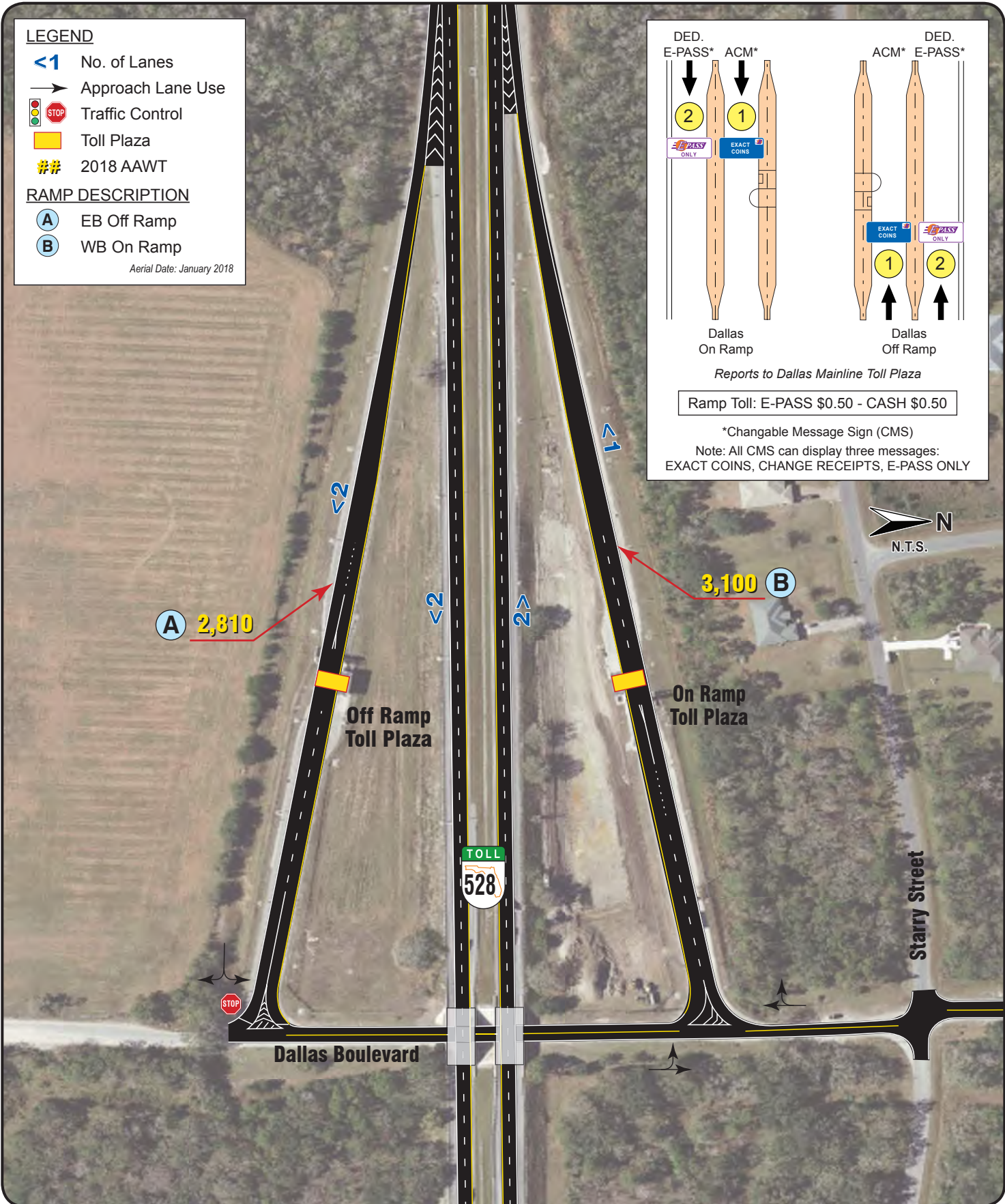
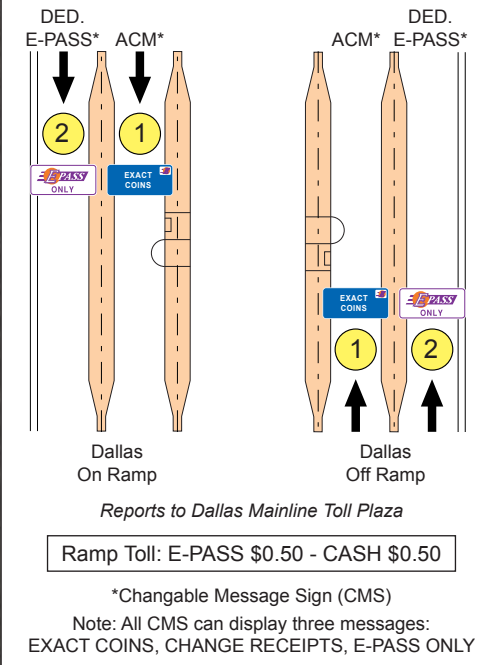

- A** EB Off Ramp
- B** WB On Ramp

Aerial Date: January 2018





**SR 528 (BEACHLINE EXPRESSWAY)
Exit 24 - Dallas Boulevard**

LEGEND

-  No. of Lanes
-  Approach Lane Use
-  Traffic Control
-  Toll Plaza
-  2018 AAWT

RAMP DESCRIPTION

-  EB Off Ramp
-  WB On Ramp

Aerial Date: January 2018

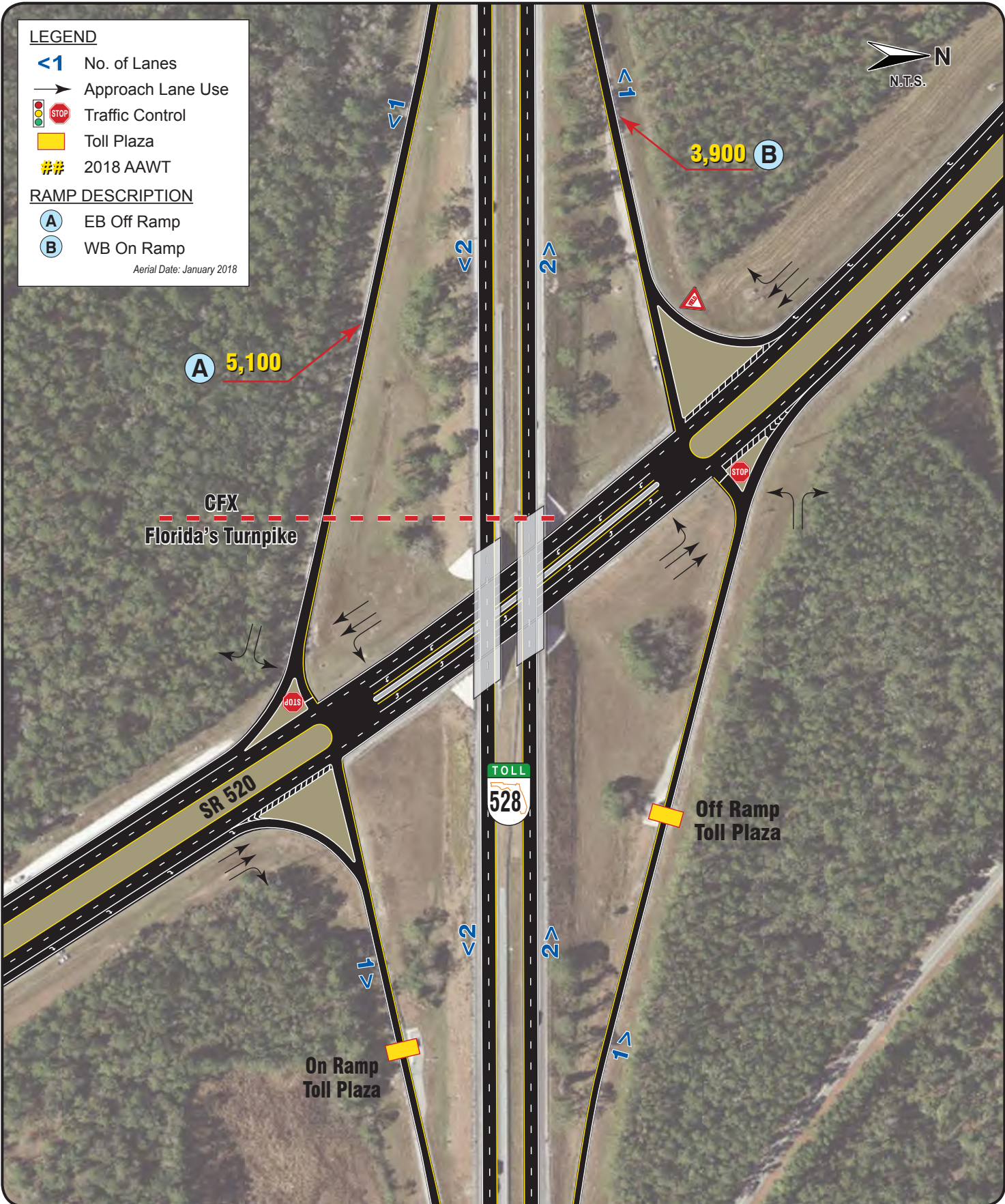

SR 528 (BEACHLINE EXPRESSWAY)
Exit 31 - SR 520

SECTION IV

Central Florida GreeneWay



2018 Traffic Data and Statistics Manual
CENTRAL FLORIDA EXPRESSWAY AUTHORITY



LEGEND

- Exit Number
- Existing SR 417
- Mainline Toll Plaza



SR 417 - CENTRAL FLORIDA GREENEWAY
Exit Numbers

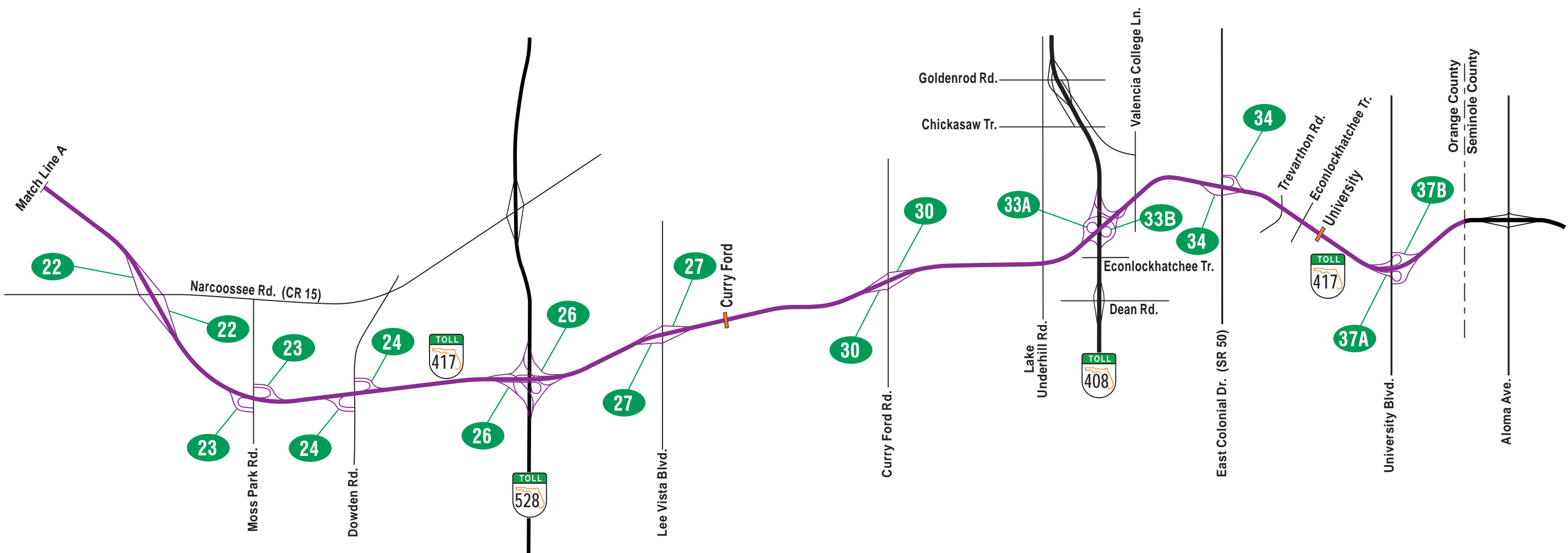

LEGEND

- Exit Number
- Existing SR 417
- Mainline Toll Plaza



SR 417 - CENTRAL FLORIDA GREENEWAY
Exit Numbers

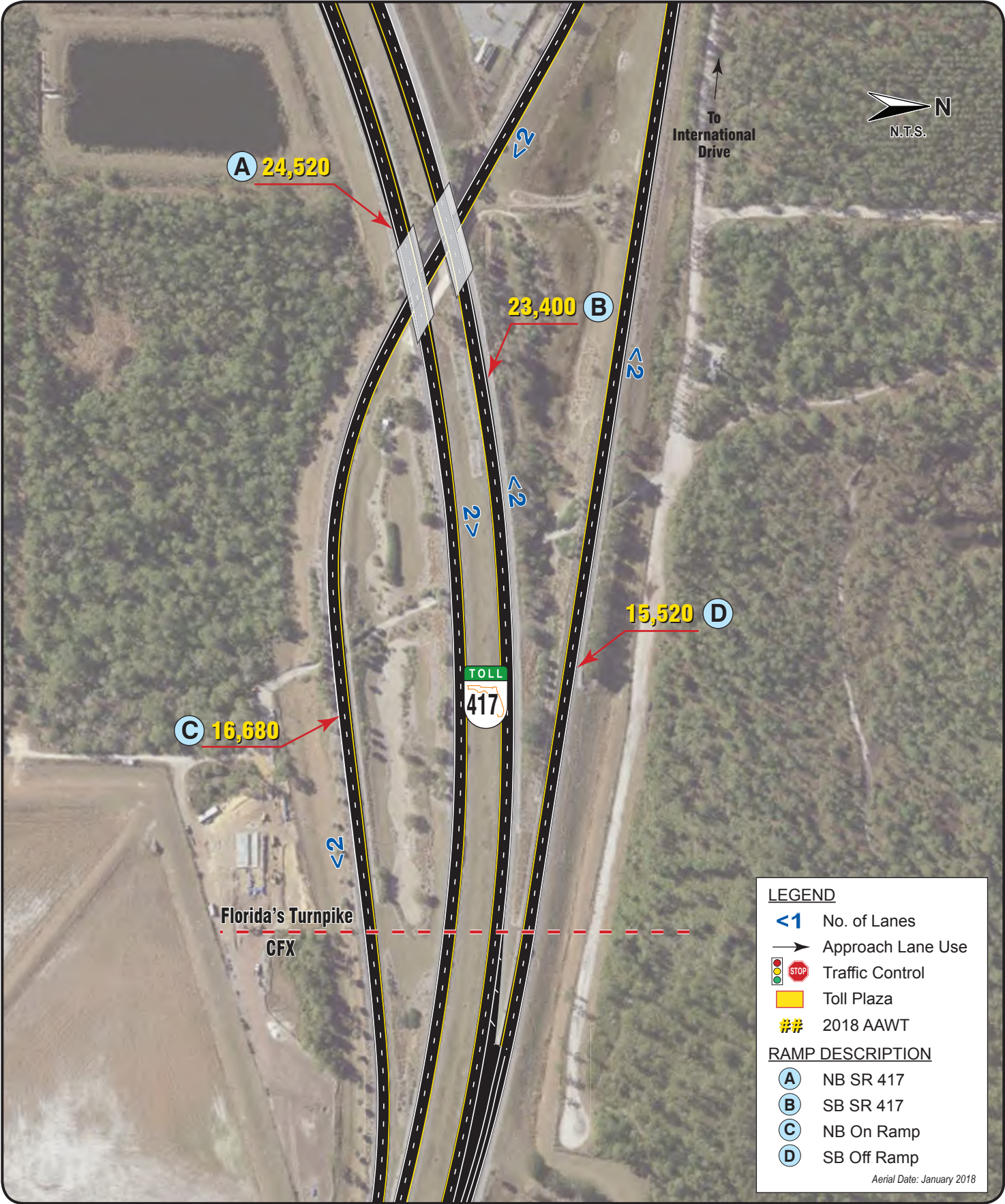

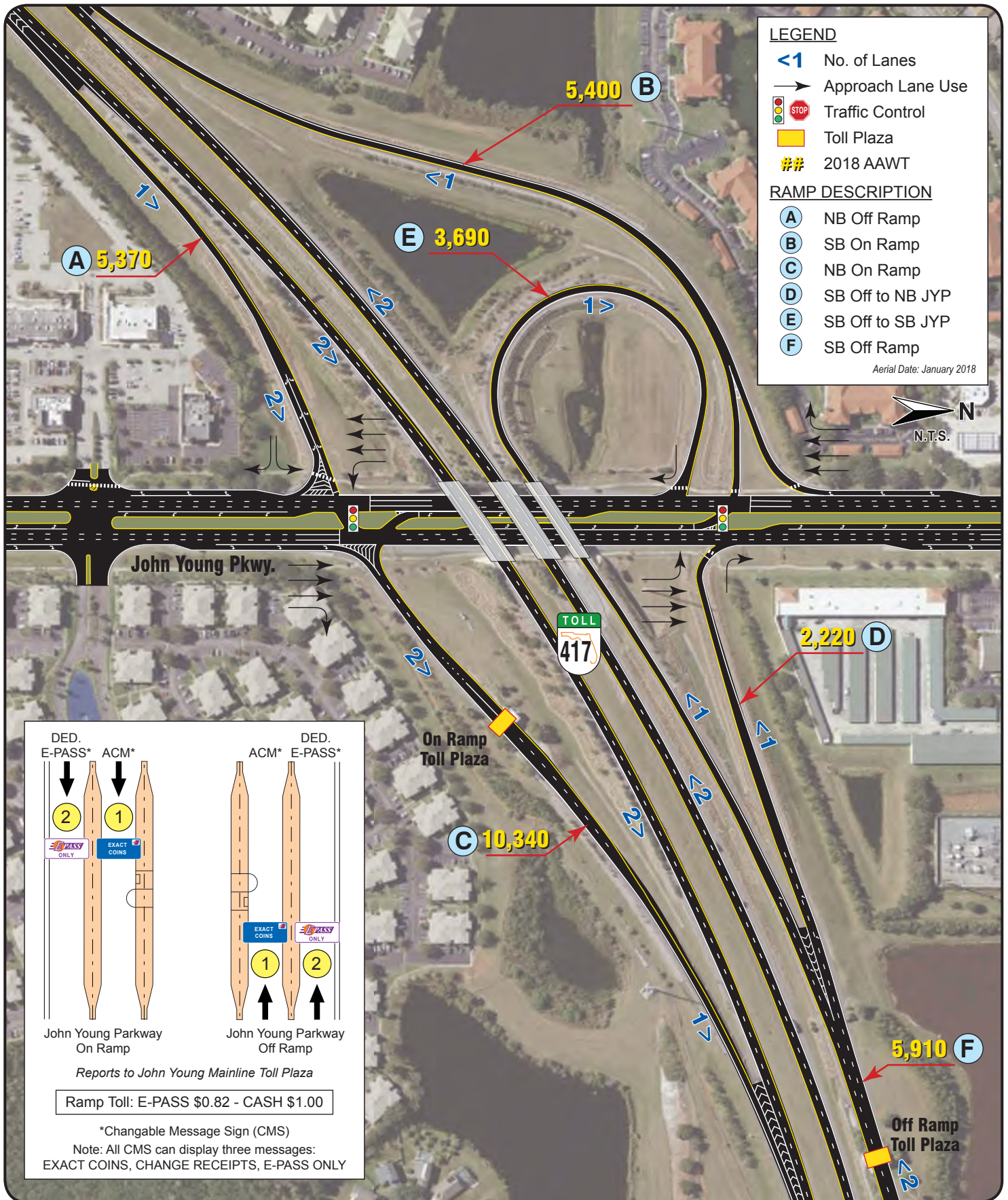

DED. E-PASS*	ACM*	DED. ACM*	DED. E-PASS*
2	1	1	2
E-PASS ONLY	EXACT COINS	EXACT COINS	E-PASS ONLY
John Young Parkway On Ramp		John Young Parkway Off Ramp	
Reports to John Young Mainline Toll Plaza			
Ramp Toll: E-PASS \$0.82 - CASH \$1.00			
*Changable Message Sign (CMS)			
Note: All CMS can display three messages: EXACT COINS, CHANGE RECEIPTS, E-PASS ONLY			



SR 417 (CENTRAL FLORIDA GREENEWAY) Exit 10 - John Young Parkway

SECTION IV

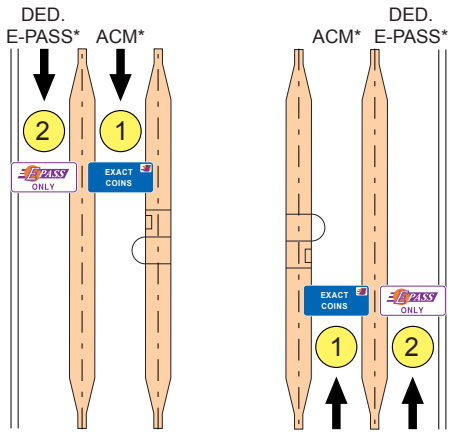

Orange Blossom Trail On Ramp
Orange Blossom Trail Off Ramp

Reports to John Young Mainline Toll Plaza

Ramp Toll: E-PASS \$0.55 - CASH \$0.75

*Changable Message Sign (CMS)

Note: All CMS can display three messages:
EXACT COINS, CHANGE RECEIPTS, E-PASS ONLY



LEGEND

- <1 No. of Lanes
- Approach Lane Use
- STOP Traffic Control
- Toll Plaza
- ## 2018 AAWT

RAMP DESCRIPTION

- (A) NB Off Ramp
- (B) SB On Ramp
- (C) NB On Ramp
- (D) SB Off Ramp

Aerial Date: January 2018

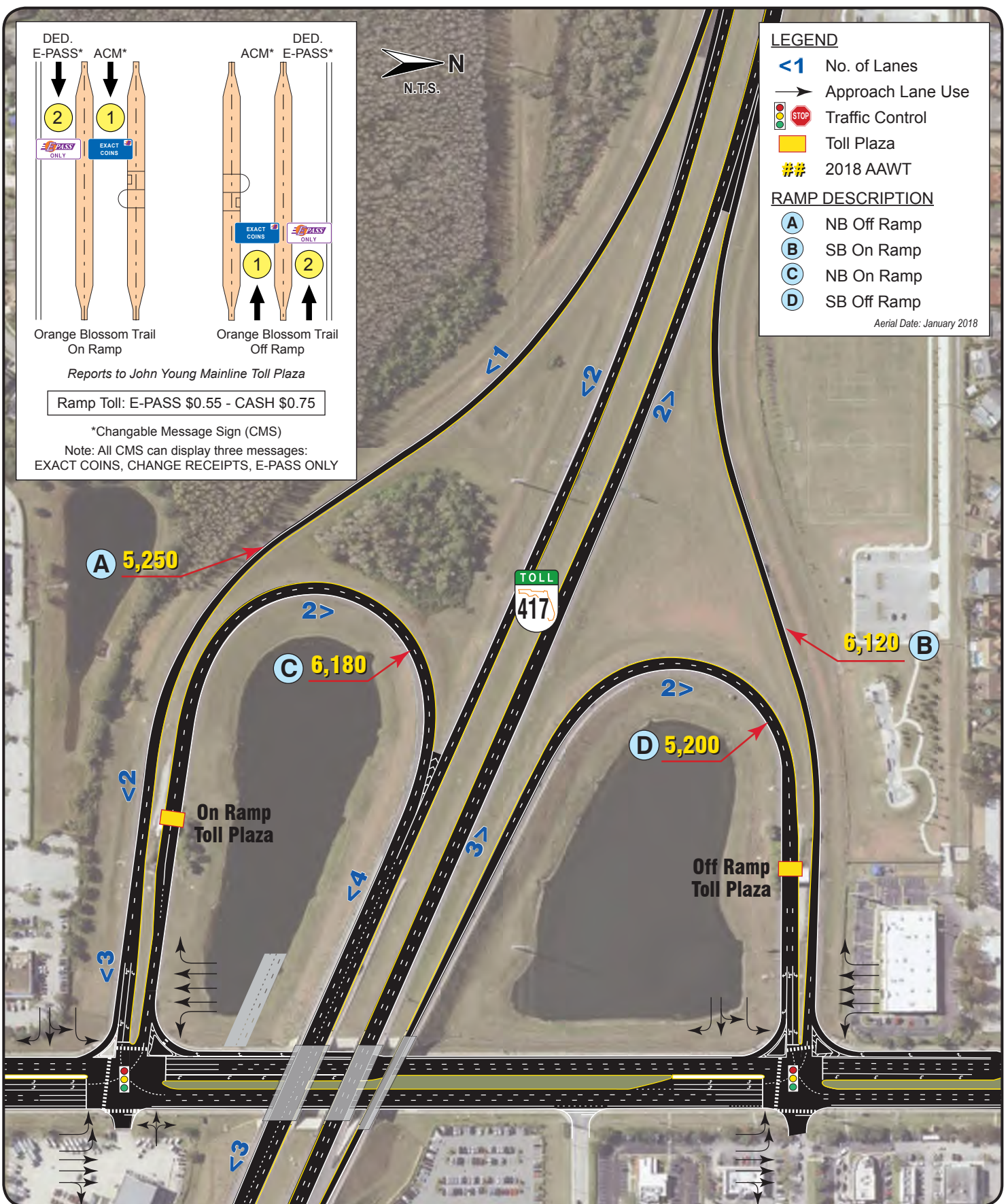

**SR 417 (CENTRAL FLORIDA GREENEWAY)
Exit 11 - US 17-92/US 441 Orange Blossom Trail**

SECTION IV

260



LEGEND

- <1 No. of Lanes
- Approach Lane Use
- Traffic Control
- Toll Plaza
- ## 2018 AAWT

RAMP DESCRIPTION

- A** SB Off to SB Turnpike
- B** NB On from NB Turnpike
- C** SB OFF to NB Turnpike
- D** NB Off to SB Turnpike
- E** NB Off to NB Turnpike

Aerial Date: January 2018

Town Center Blvd.



SR 417 (CENTRAL FLORIDA GREENEWAY)
Exit 12 - Florida's Turnpike

SECTION IV

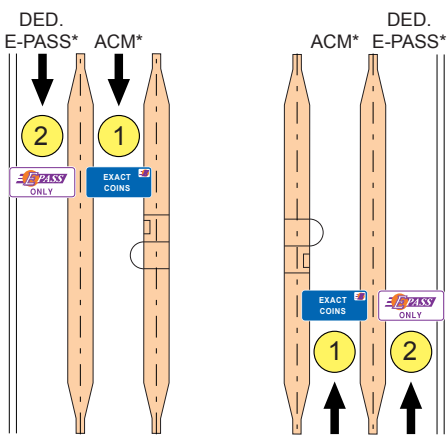

Landstar Off Ramp
Landstar On Ramp

Reports to John Young Mainline Toll Plaza

Ramp Toll: E-PASS \$0.50 - CASH \$0.50

*Changable Message Sign (CMS)

Note: All CMS can display three messages:
EXACT COINS, CHANGE RECEIPTS, E-PASS ONLY

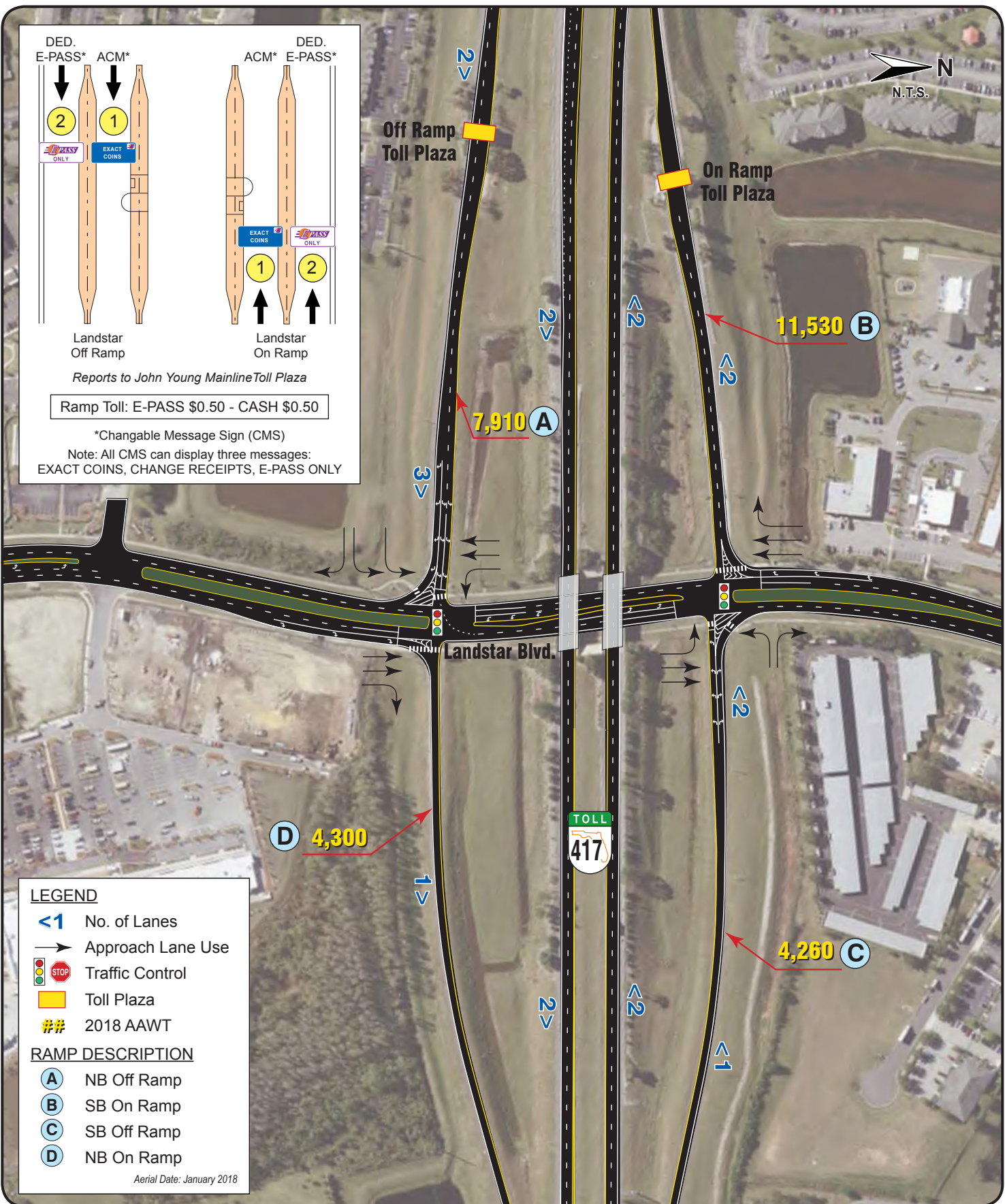

LEGEND

- No. of Lanes
- Approach Lane Use
- Traffic Control
- Toll Plaza
- 2018 AAWT

RAMP DESCRIPTION

- NB Off Ramp
- SB On Ramp
- SB Off Ramp
- NB On Ramp

Aerial Date: January 2018



**SR 417 (CENTRAL FLORIDA GREENWAY)
Exit 14 - Landstar Boulevard**

SECTION IV

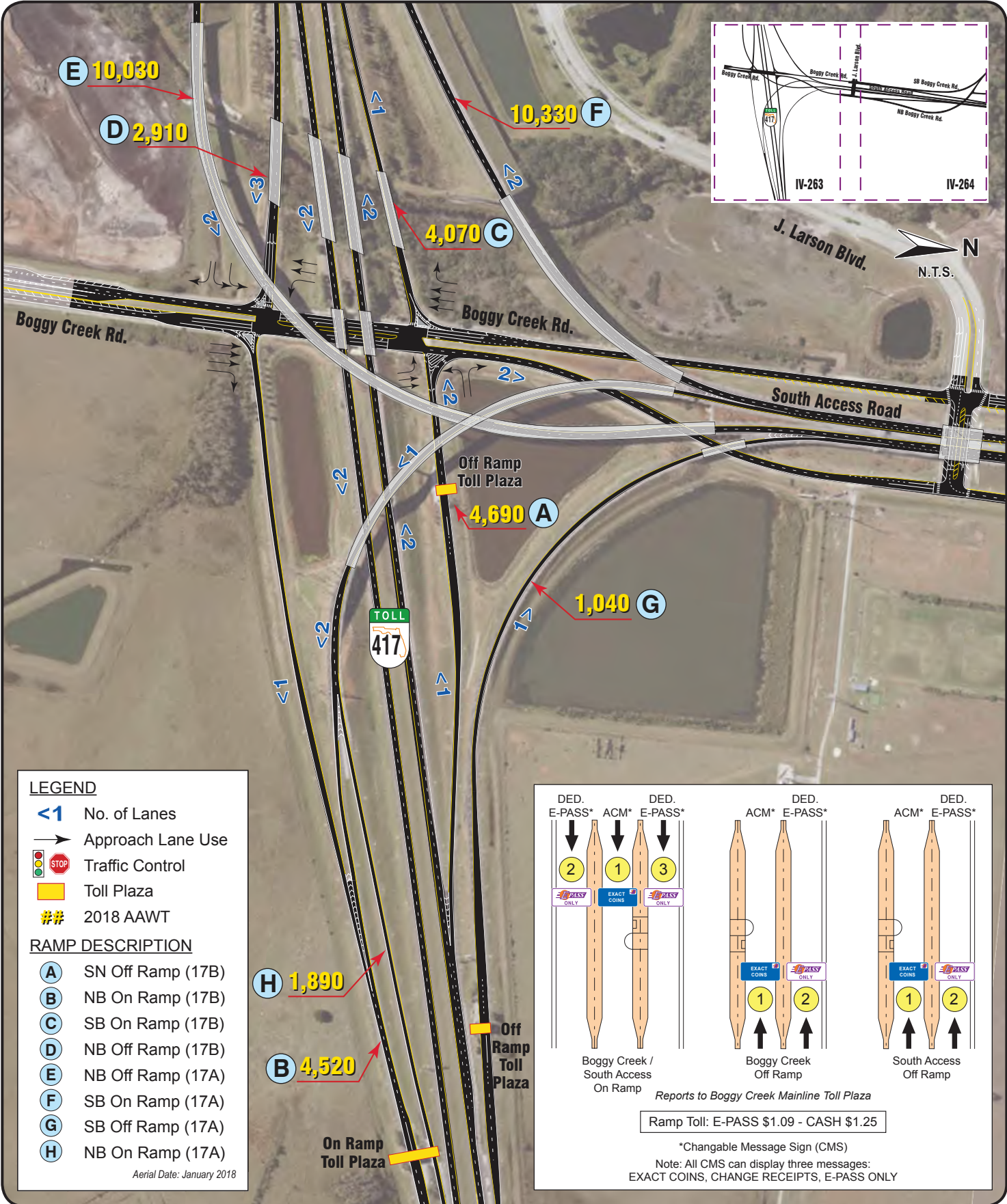

LEGEND

- <1 No. of Lanes
- Approach Lane Use
- ⊙ STOP Traffic Control
- Toll Plaza
- ## 2018 AAWT

RAMP DESCRIPTION

- A SN Off Ramp (17B)
- B NB On Ramp (17B)
- C SB On Ramp (17B)
- D NB Off Ramp (17B)
- E NB Off Ramp (17A)
- F SB On Ramp (17A)
- G SB Off Ramp (17A)
- H NB On Ramp (17A)

Aerial Date: January 2018

DED. E-PASS*	ACM*	DED. E-PASS*	DED. E-PASS*	DED. E-PASS*	DED. E-PASS*	
2	1	3	1	2	1	
Boggy Creek / South Access On Ramp			Boggy Creek Off Ramp		South Access Off Ramp	
Reports to Boggy Creek Mainline Toll Plaza						
Ramp Toll: E-PASS \$1.09 - CASH \$1.25						
*Changable Message Sign (CMS)						
Note: All CMS can display three messages: EXACT COINS, CHANGE RECEIPTS, E-PASS ONLY						



SR 417 (CENTRAL FLORIDA GREENEWAY)
Exit 17A&B - Boggy Creek Road and South Access Road (1)

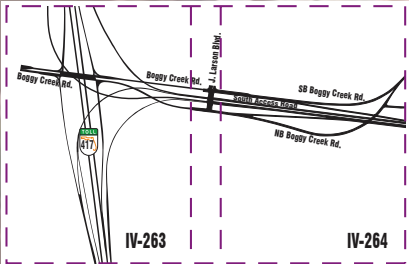
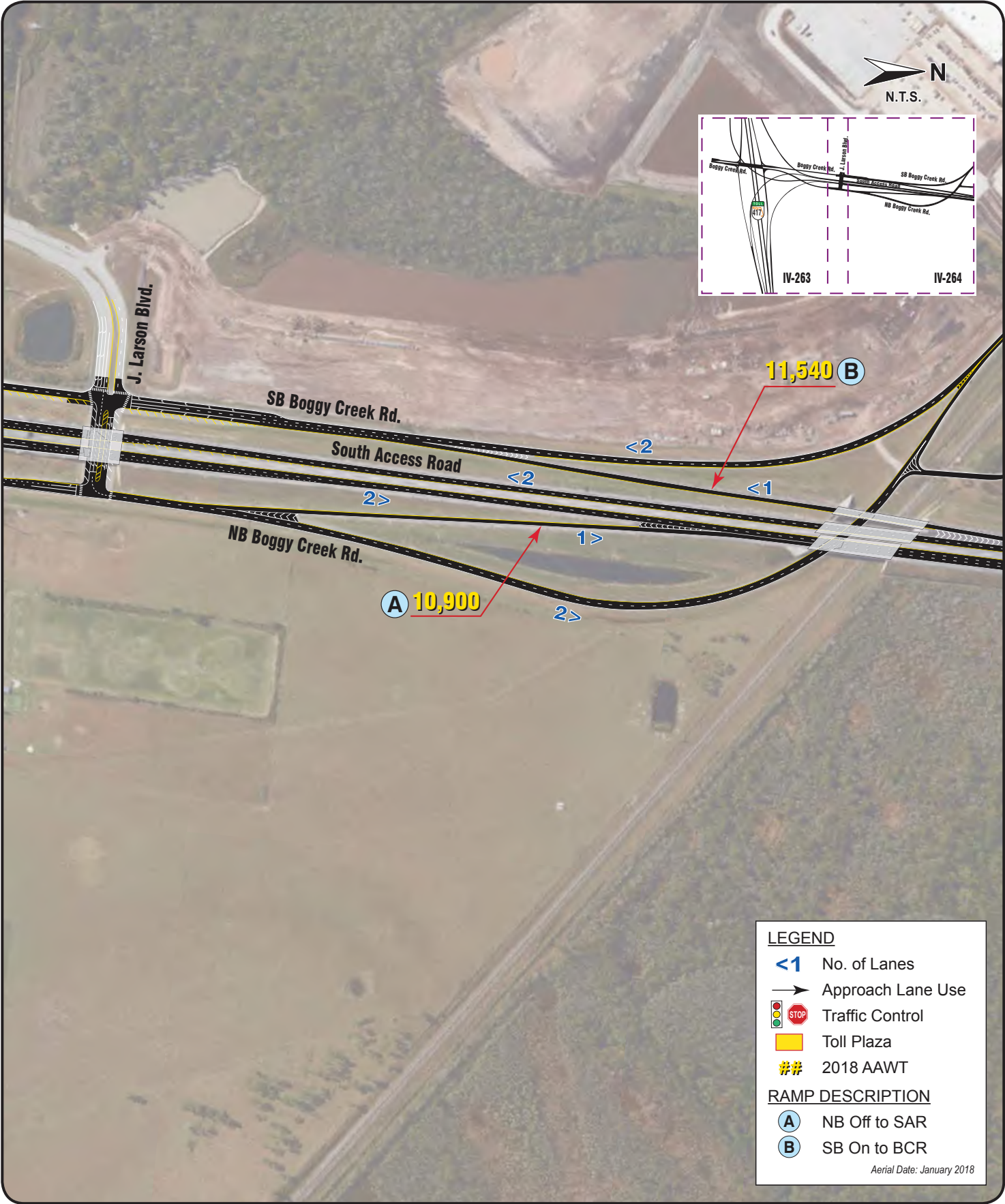

11,540 **B**

A 10,900

LEGEND

- <1 No. of Lanes
- Approach Lane Use
- Traffic Control
- Toll Plaza
- ## 2018 AAWT

RAMP DESCRIPTION

- A** NB Off to SAR
- B** SB On to BCR

Aerial Date: January 2018



SR 417 (CENTRAL FLORIDA GREENEWAY)
Exit 17A&B - Boggy Creek Road and South Access Road (2)

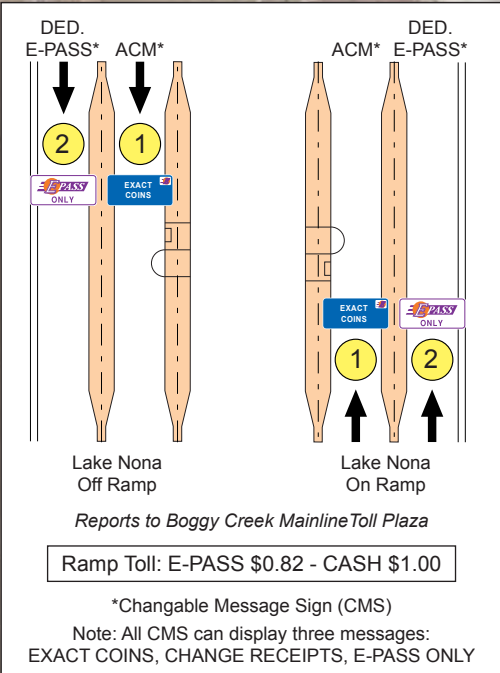
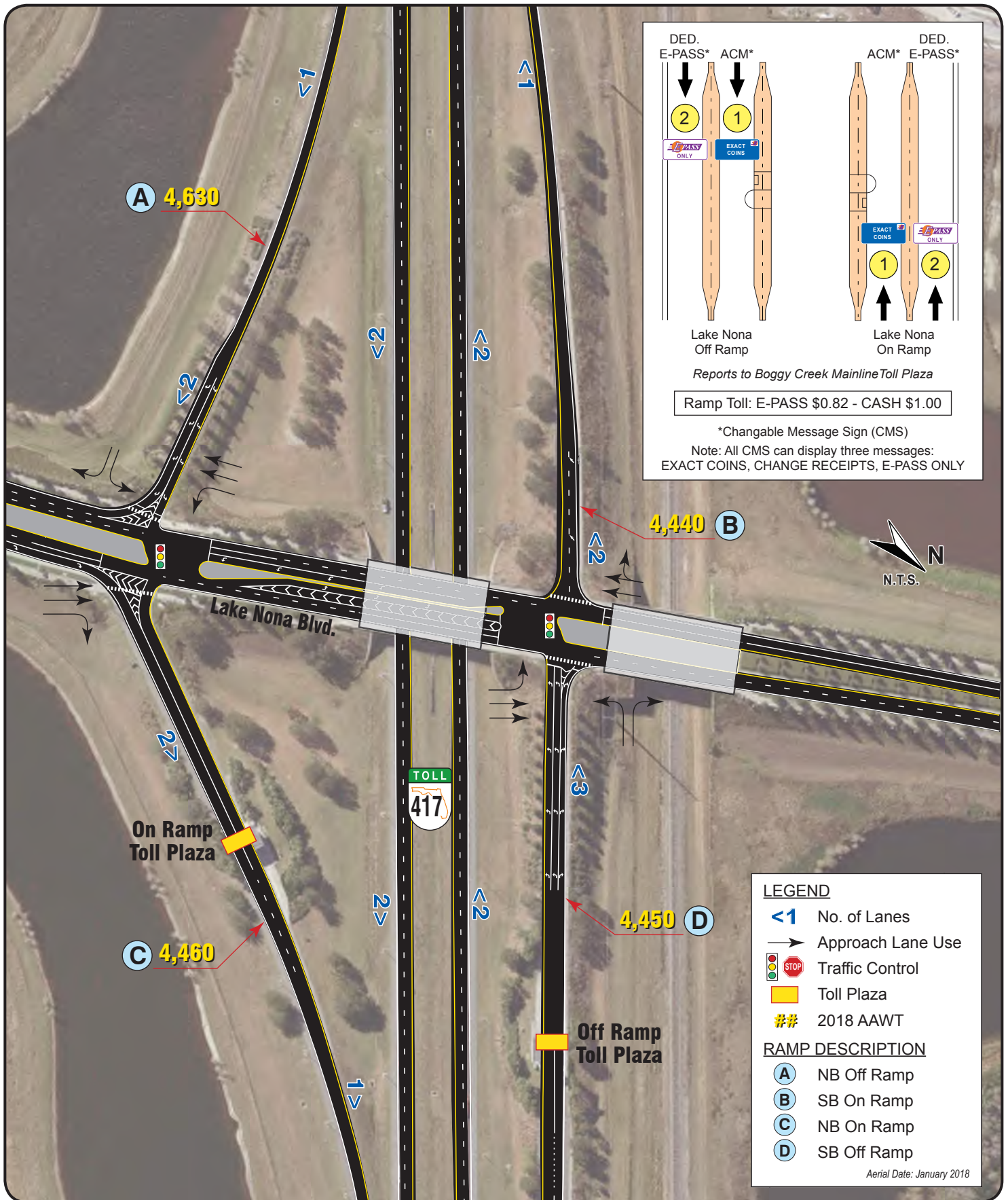

LEGEND

- <1 No. of Lanes
- Approach Lane Use
- STOP Traffic Control
- Toll Plaza
- ## 2018 AAWT

RAMP DESCRIPTION

- (A) NB Off Ramp
- (B) SB On Ramp
- (C) NB On Ramp
- (D) SB Off Ramp

Aerial Date: January 2018

LEGEND

- <1 No. of Lanes
- ➔ Approach Lane Use
- STOP Traffic Control
- Yellow Box Toll Plaza
- ## 2018 AAWT

RAMP DESCRIPTION

- A NB Off Ramp
- B SB On Ramp
- C NB On Ramp
- D SB Off Ramp

Aerial Date: January 2018

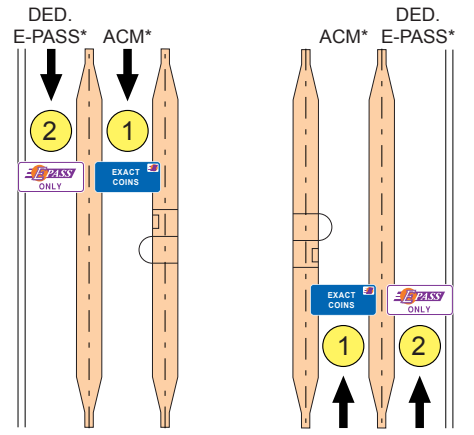

Narcoossee Off Ramp
 Narcoossee On Ramp
 Reports to Boggy Creek Mainline Toll Plaza
 Ramp Toll: E-PASS \$0.82 - CASH \$1.00

*Changable Message Sign (CMS)
 Note: All CMS can display three messages:
 EXACT COINS, CHANGE RECEIPTS, E-PASS ONLY

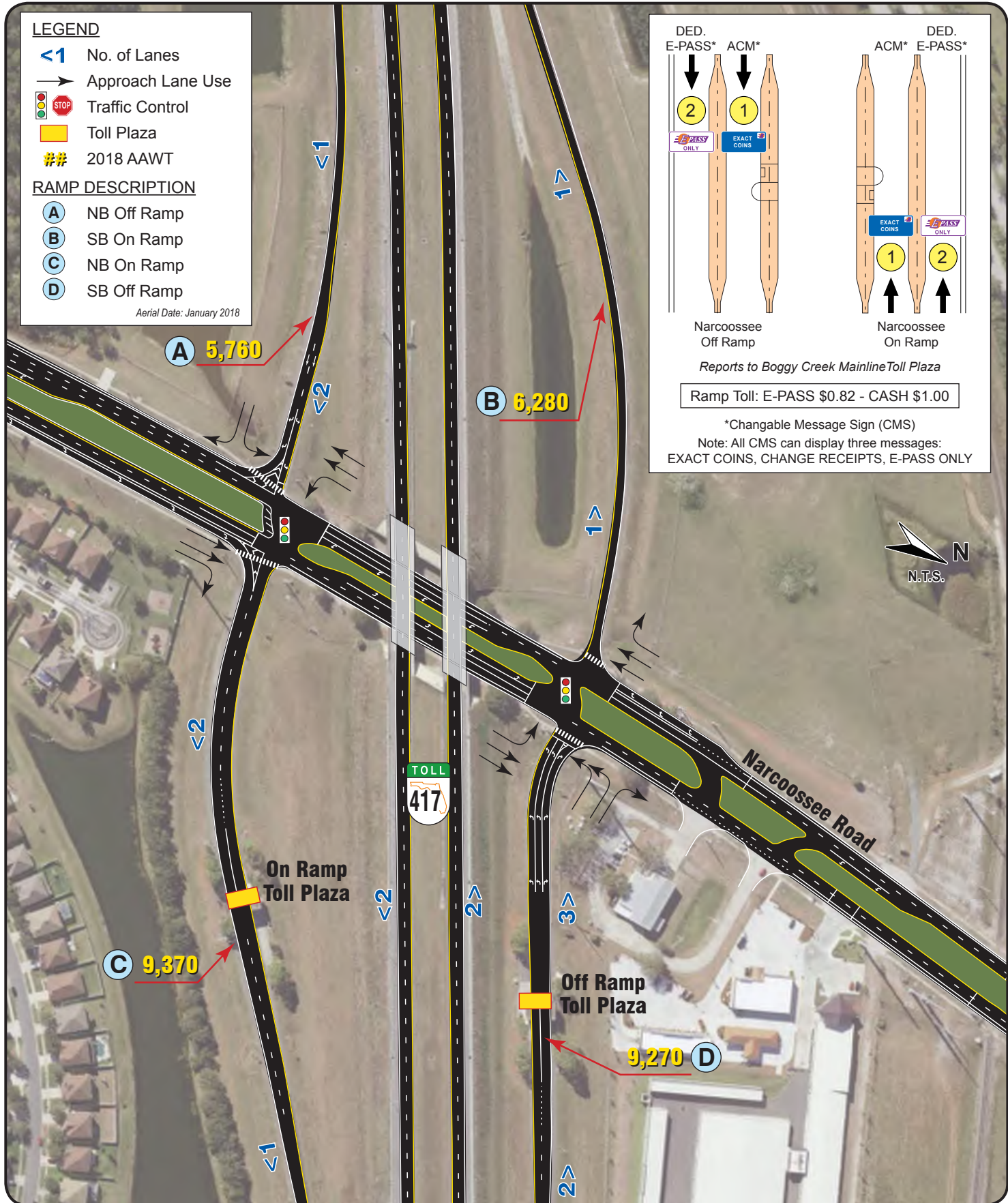

**SR 417 (CENTRAL FLORIDA GREENWAY)
 Exit 22 - Narcoossee Road (CR 15)**

SECTION IV

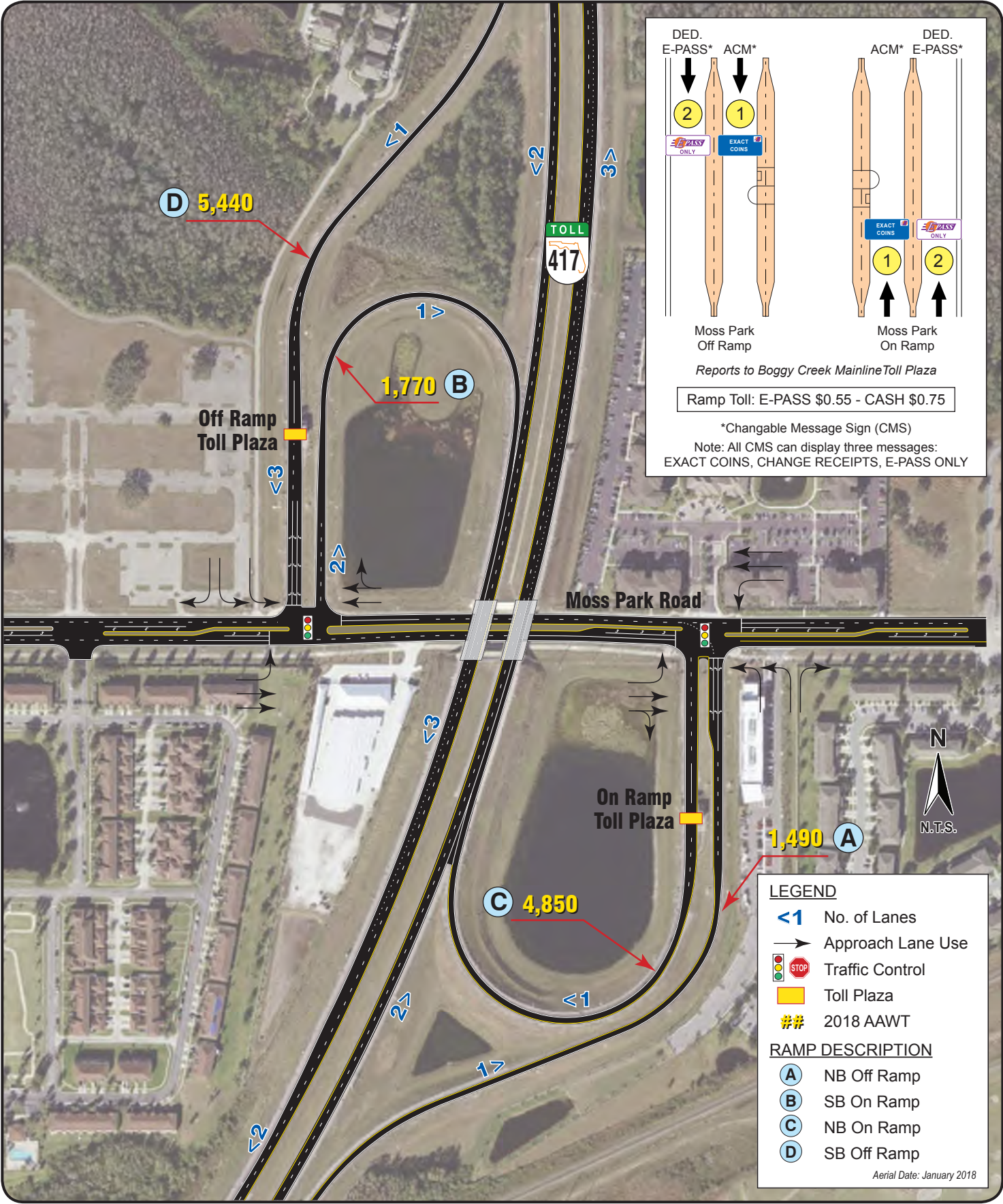

DED. E-PASS* ACM* ACM* DED. E-PASS*

2 1 1 2

ONLY EXACT COINS EXACT COINS ONLY

Moss Park Off Ramp Moss Park On Ramp

Reports to Bogy Creek Mainline Toll Plaza

Ramp Toll: E-PASS \$0.55 - CASH \$0.75

*Changable Message Sign (CMS)

Note: All CMS can display three messages: EXACT COINS, CHANGE RECEIPTS, E-PASS ONLY

LEGEND

- <1 No. of Lanes
- Approach Lane Use
- STOP Traffic Control
- Yellow Square Toll Plaza
- ## 2018 AAWT

RAMP DESCRIPTION

(A)	NB Off Ramp
(B)	SB On Ramp
(C)	NB On Ramp
(D)	SB Off Ramp

Aerial Date: January 2018

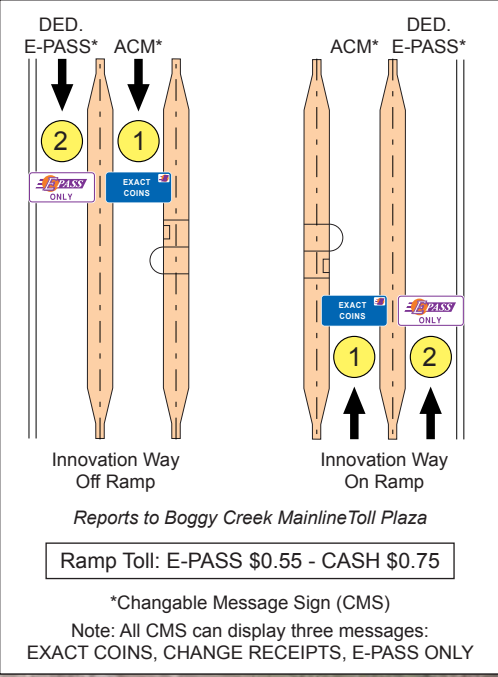
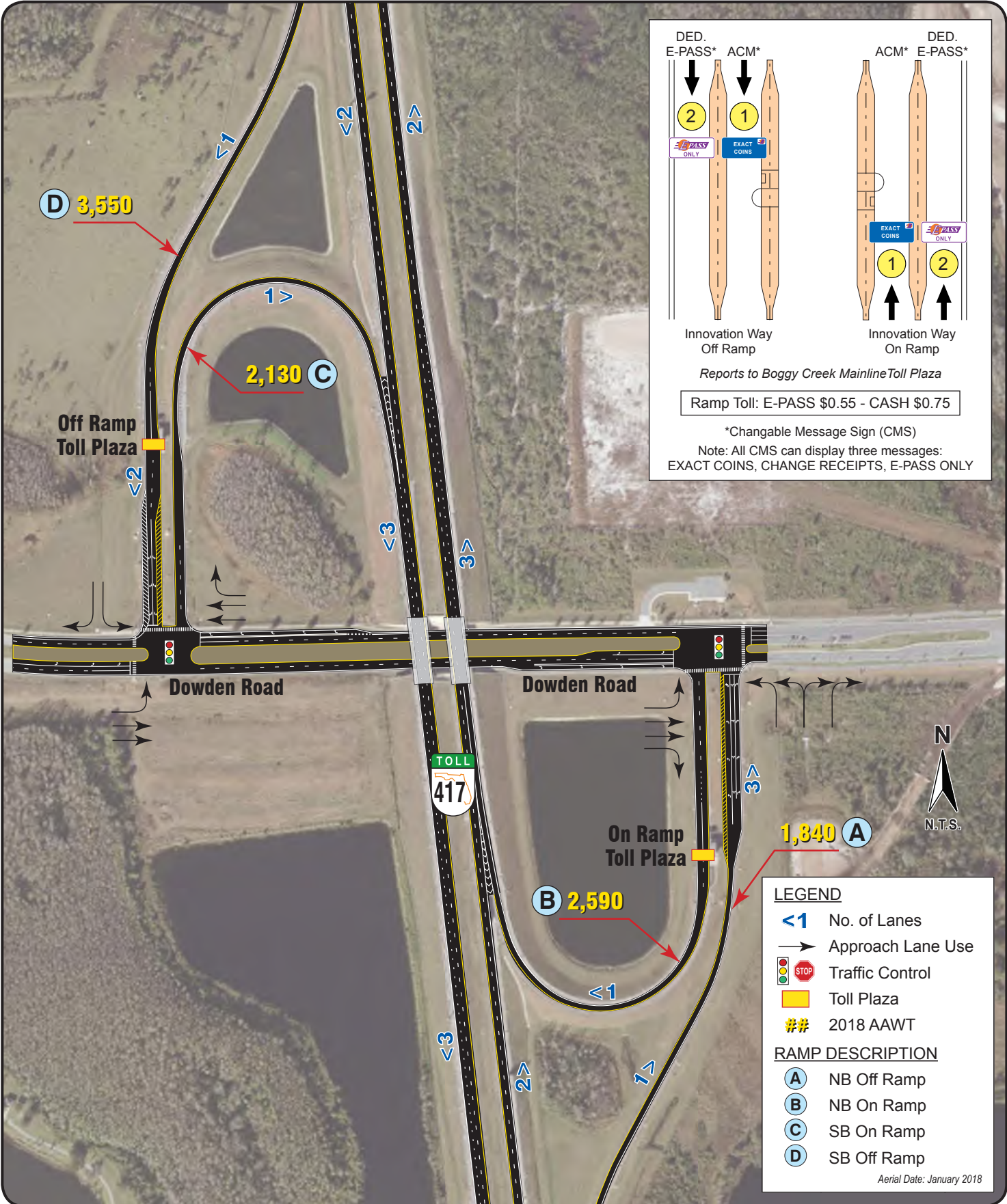

LEGEND

- <1 No. of Lanes
- Approach Lane Use
- STOP Traffic Control
- Toll Plaza
- ## 2018 AAWT

RAMP DESCRIPTION

- (A) NB Off Ramp
- (B) NB On Ramp
- (C) SB On Ramp
- (D) SB Off Ramp

Aerial Date: January 2018



**SR 417 (CENTRAL FLORIDA GREENEWAY)
Exit 24 - Dowden Road**

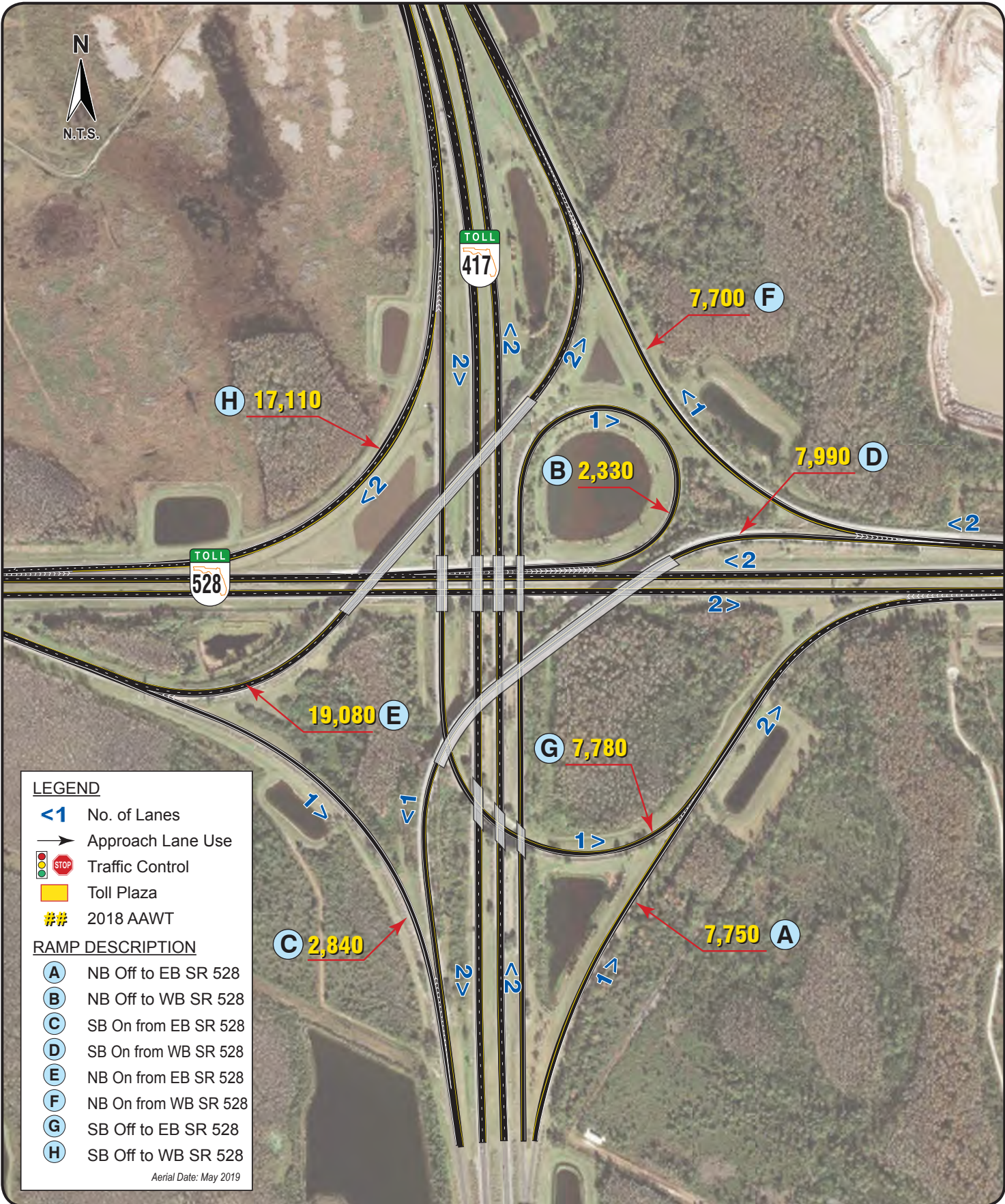

LEGEND

- <1 No. of Lanes
- Approach Lane Use
- Traffic Control
- Toll Plaza
- ## 2018 AAWT

RAMP DESCRIPTION

- A** NB Off to EB SR 528
- B** NB Off to WB SR 528
- C** SB On from EB SR 528
- D** SB On from WB SR 528
- E** NB On from EB SR 528
- F** NB On from WB SR 528
- G** SB Off to EB SR 528
- H** SB Off to WB SR 528

Aerial Date: May 2019



**SR 417 (CENTRAL FLORIDA GREENEWAY)
Exit 26 - Beachline Expressway (SR 528)**

SECTION IV

269

LEGEND

- <1 No. of Lanes
- Approach Lane Use
- Traffic Control
- Toll Plaza
- ## 2018 AAWT

RAMP DESCRIPTION

- A** SB Off Ramp
- B** NB On Ramp
- C** SB On Ramp
- D** NB Off Ramp

Aerial Date: January 2018

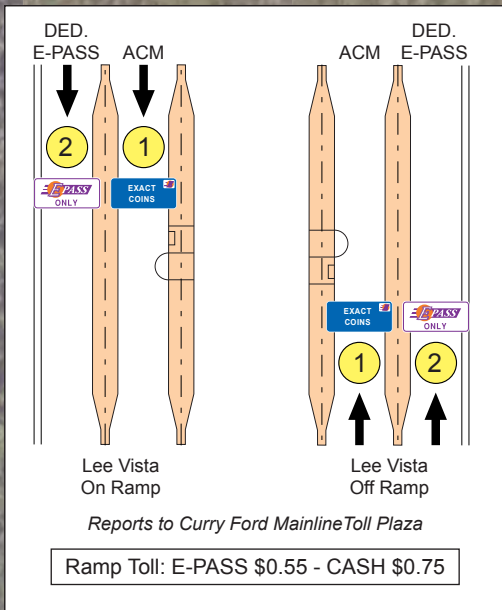
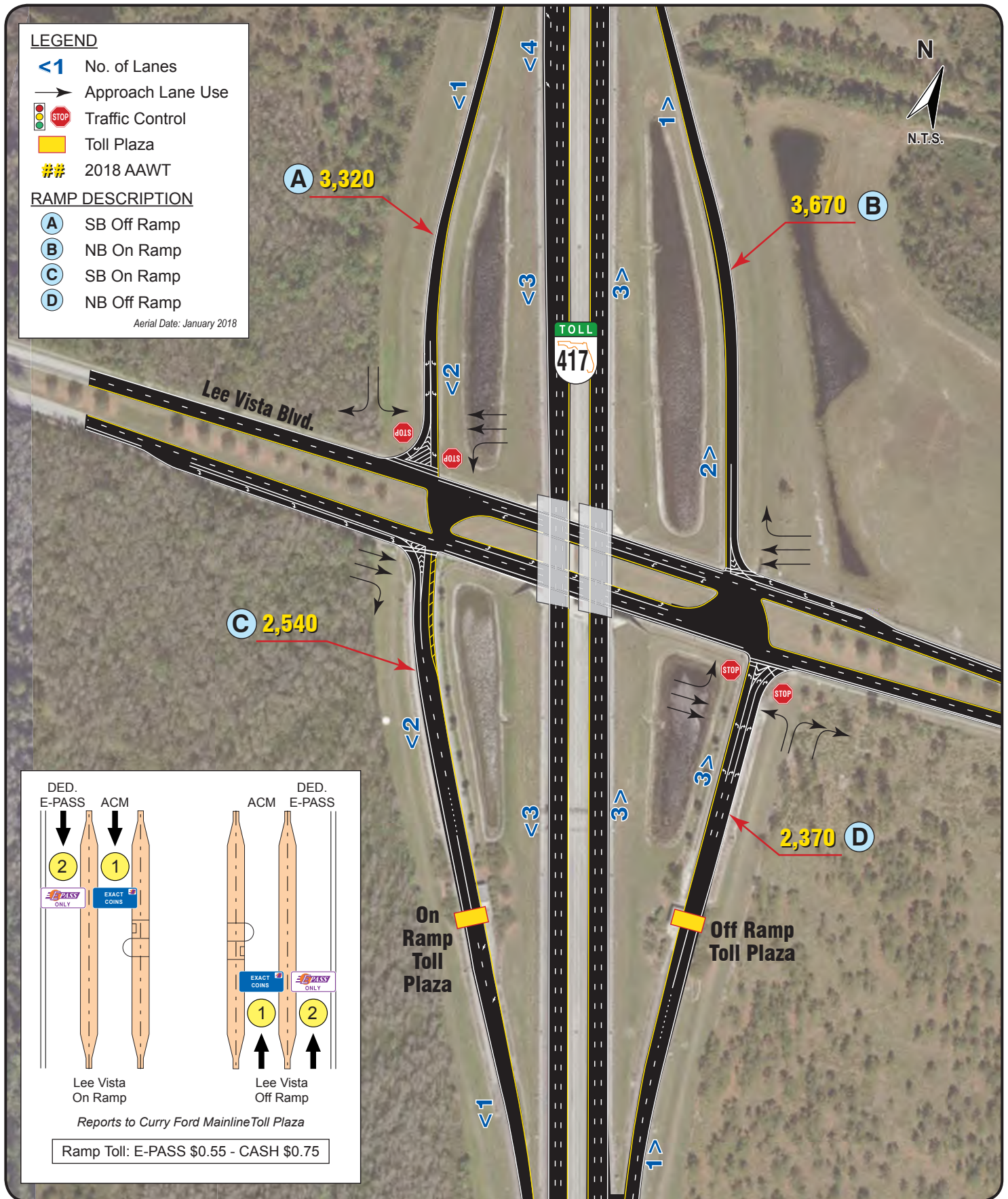

**SR 417 (CENTRAL FLORIDA GREENEWAY)
Exit 27 - Lee Vista Boulevard**

SECTION IV

270



LEGEND

- <1 No. of Lanes
- Approach Lane Use
- STOP Traffic Control
- Toll Plaza
- ## 2018 AAWT

RAMP DESCRIPTION

- (A) SB Off Ramp
- (B) NB On Ramp
- (C) SB On Ramp
- (D) NB Off Ramp

Aerial Date: January 2018

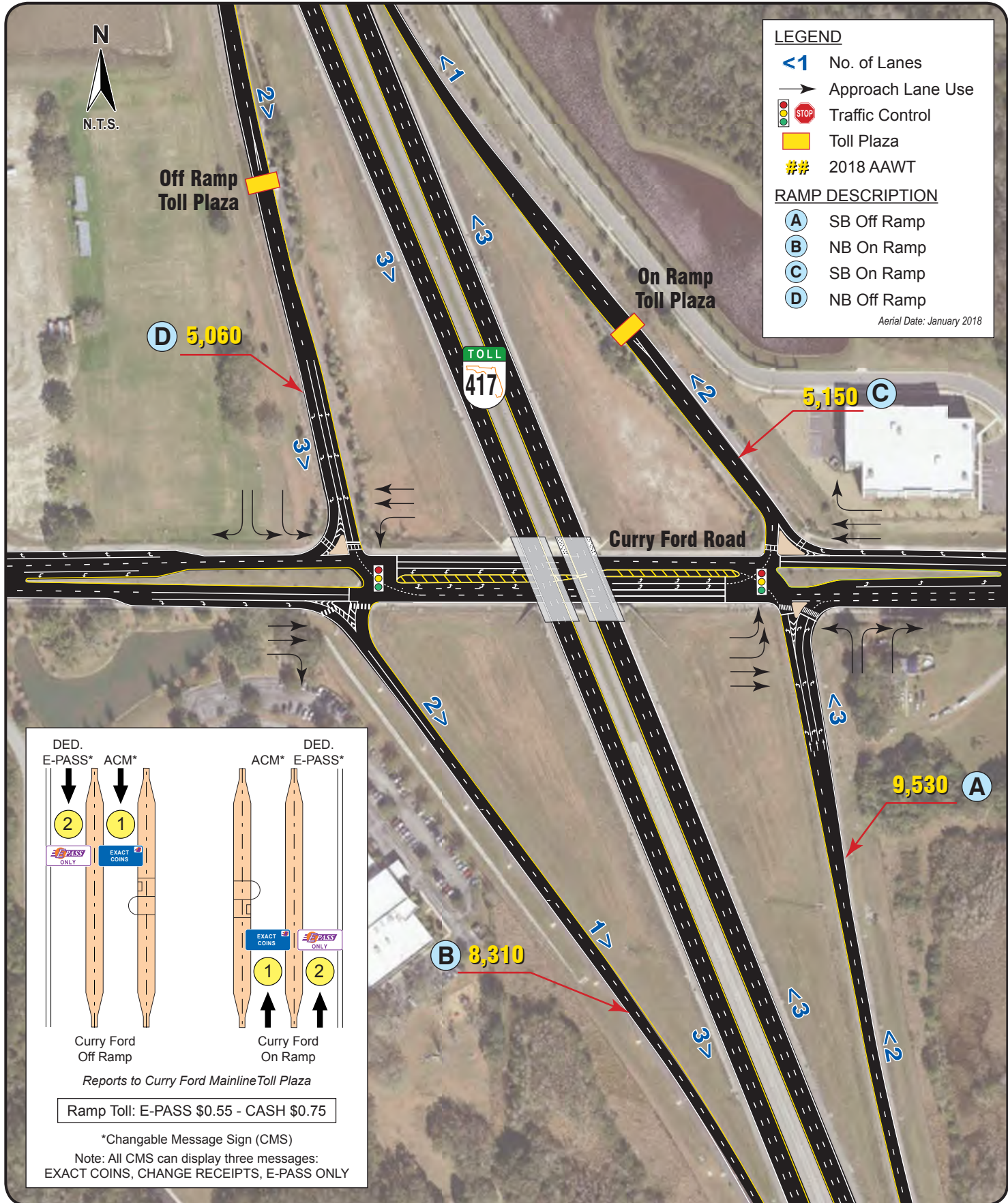

DED. E-PASS*	ACM*	DED. ACM*	E-PASS*
↓	↓		↑
2	1	1	2
E-PASS ONLY	EXACT COINS	EXACT COINS	E-PASS ONLY
Curry Ford Off Ramp		Curry Ford On Ramp	
Reports to Curry Ford Mainline Toll Plaza			
Ramp Toll: E-PASS \$0.55 - CASH \$0.75			
*Changable Message Sign (CMS)			
Note: All CMS can display three messages: EXACT COINS, CHANGE RECEIPTS, E-PASS ONLY			



SR 417 (CENTRAL FLORIDA GREENEWAY)
Exit 30 - Curry Ford Road

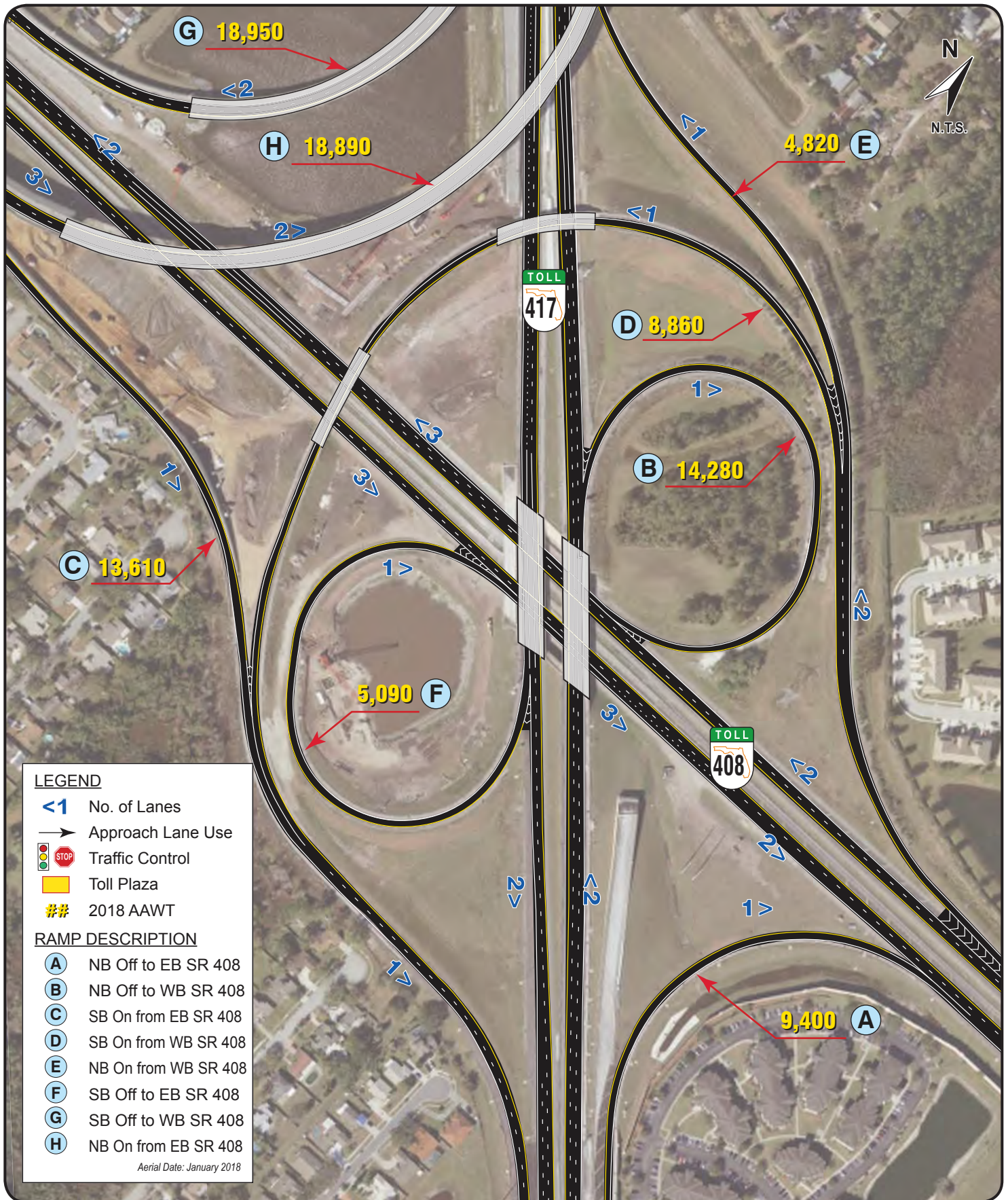

LEGEND

- <1 No. of Lanes
- Approach Lane Use
- Traffic Control
- Toll Plaza
- ## 2018 AAWT

RAMP DESCRIPTION

- A** NB Off to EB SR 408
- B** NB Off to WB SR 408
- C** SB On from EB SR 408
- D** SB On from WB SR 408
- E** NB On from WB SR 408
- F** SB Off to EB SR 408
- G** SB Off to WB SR 408
- H** NB On from EB SR 408

Aerial Date: January 2018



SR 417 (CENTRAL FLORIDA GREENEWAY)
Exit 33A & 33B - East-West Expressway (SR 408)

SECTION IV



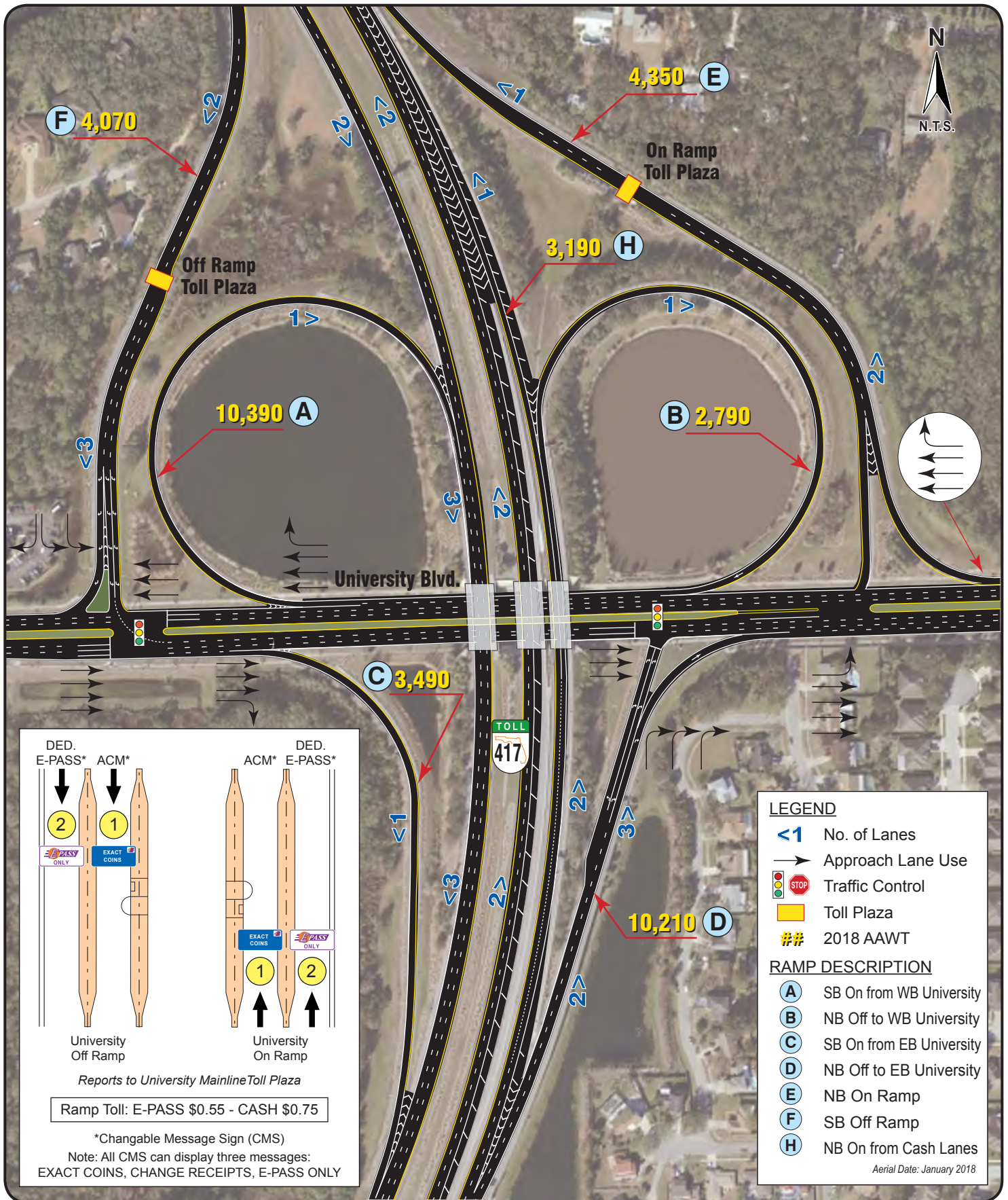

DED. E-PASS*	ACM*	DED. ACM*	DED. E-PASS*
2	1	1	2
EXACT COINS ONLY	EXACT COINS	EXACT COINS	EXACT COINS ONLY
University Off Ramp		University On Ramp	
Reports to University Mainline Toll Plaza			
Ramp Toll: E-PASS \$0.55 - CASH \$0.75			
*Changable Message Sign (CMS)			
Note: All CMS can display three messages: EXACT COINS, CHANGE RECEIPTS, E-PASS ONLY			

LEGEND

- <1 No. of Lanes
- ➔ Approach Lane Use
- 🚦 Traffic Control
- 🟡 Toll Plaza
- ## 2018 AAWT

RAMP DESCRIPTION

- A SB On from WB University
- B NB Off to WB University
- C SB On from EB University
- D NB Off to EB University
- E NB On Ramp
- F SB Off Ramp
- H NB On from Cash Lanes

Aerial Date: January 2018



9,530 **G**

LEGEND

- <1 No. of Lanes
- Approach Lane Use
- 🚦 STOP Traffic Control
- 🟡 Toll Plaza
- ## 2018 AAWT

RAMP DESCRIPTION

- G** NB Off E-PASS Only

Aerial Date: January 2018



SR 417 (CENTRAL FLORIDA GREENEWAY)
Exit 37A - NB SR 417 Exit to University Boulevard

Western Beltway and Wekiva Parkway





Western Beltway

Wekiva Parkway

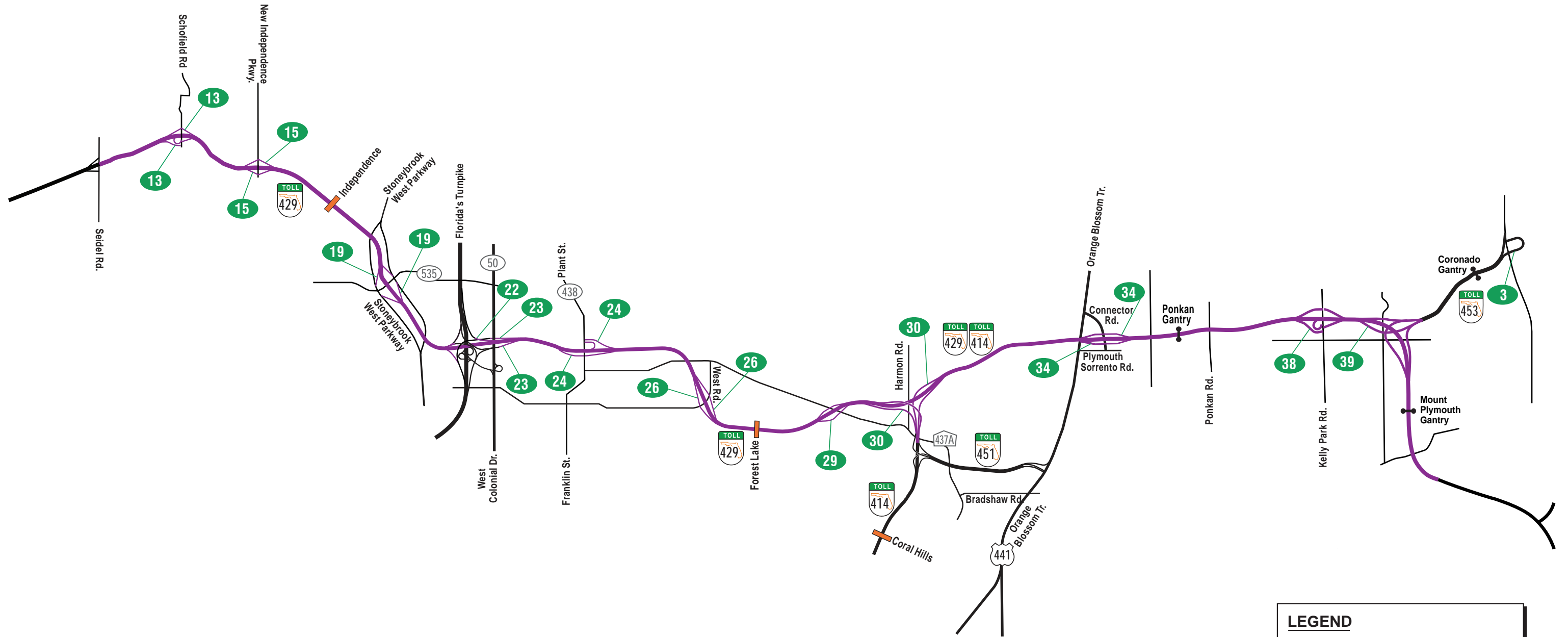

LEGEND

- Exit Number
- Existing SR 429
- Mainline Toll Plaza
- Mainline Toll Gantry



SR 429 - WESTERN BELTWAY AND WEKIVA PARKWAY
Exit Numbers

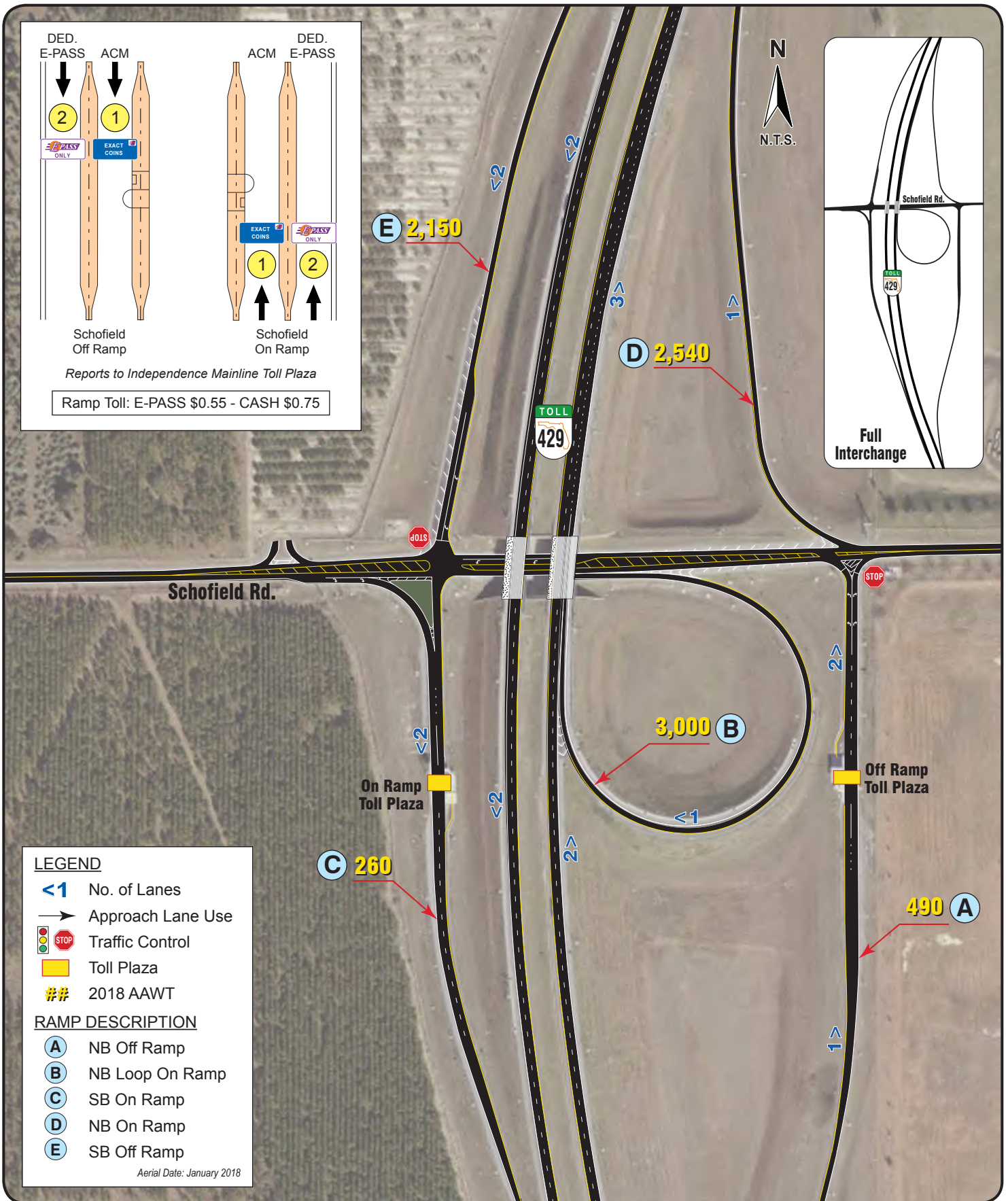
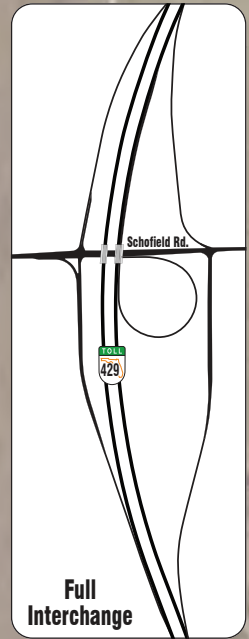
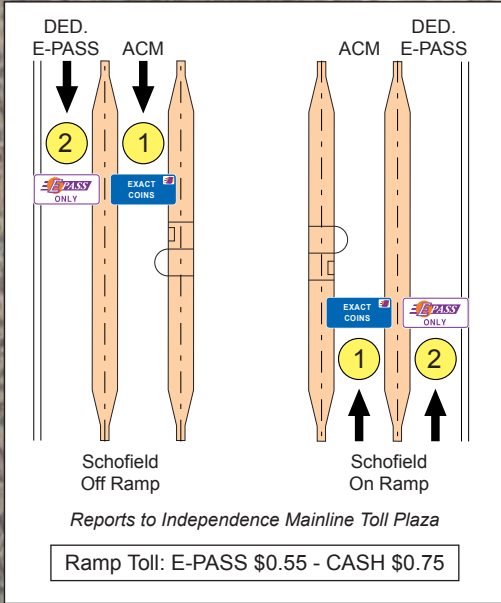

LEGEND

- <1 No. of Lanes
- Approach Lane Use
- STOP Traffic Control
- Yellow Box Toll Plaza
- ## 2018 AAWT

RAMP DESCRIPTION

- (A) NB Off Ramp
- (B) NB Loop On Ramp
- (C) SB On Ramp
- (D) NB On Ramp
- (E) SB Off Ramp

Aerial Date: January 2018



SR 429 (WESTERN BELTWAY)
Exit 13 - Schofield Road

SECTION IV

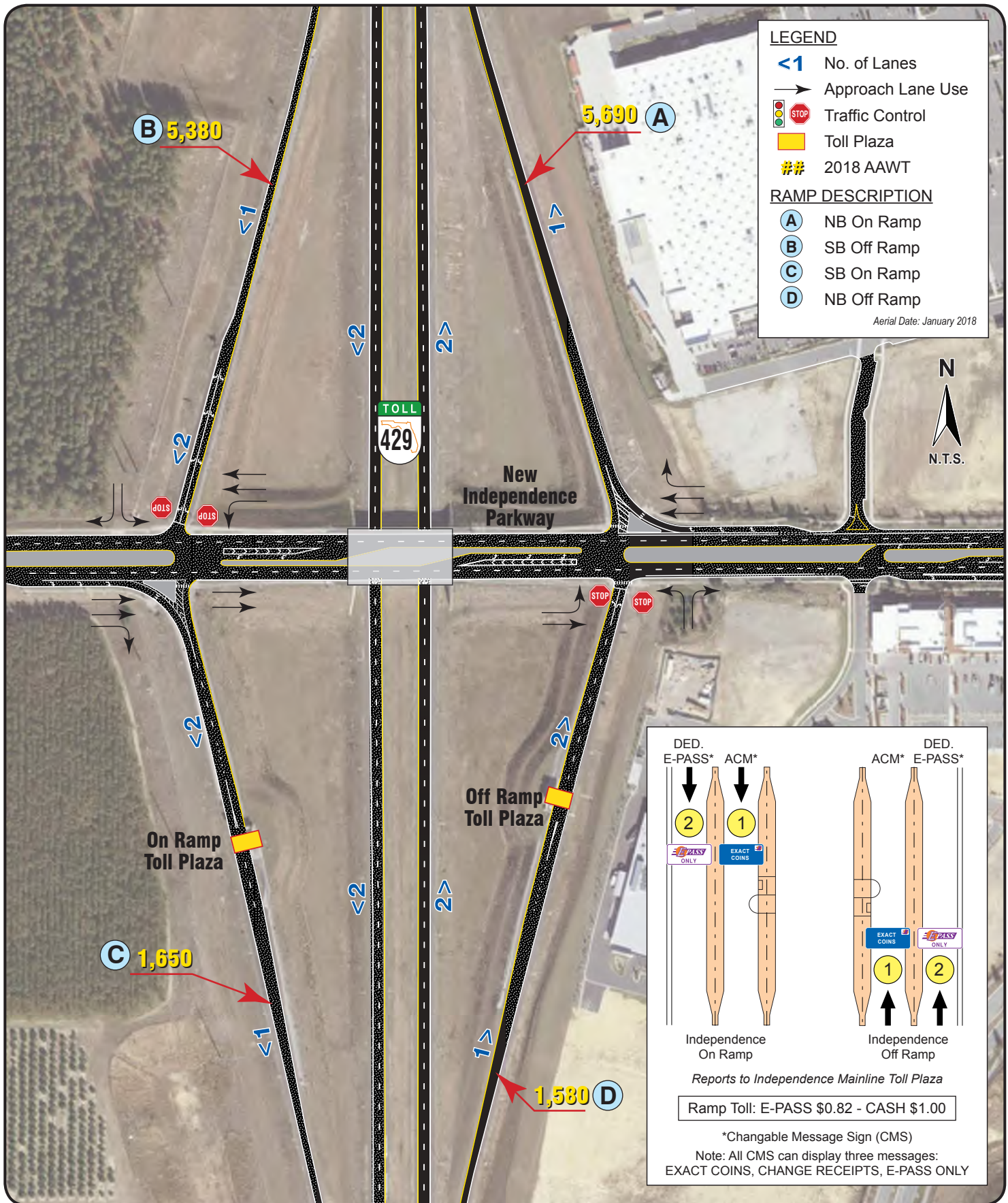

LEGEND

- <1> No. of Lanes
- Approach Lane Use
- STOP Traffic Control
- Toll Plaza
- ## 2018 AAVT

RAMP DESCRIPTION

- (A) NB On Ramp
- (B) SB Off Ramp
- (C) SB On Ramp
- (D) NB Off Ramp

Aerial Date: January 2018

DED. E-PASS*	ACM*	ACM*	DED. E-PASS*
2	1	1	2
ONLY	EXACT COINS	EXACT COINS	ONLY
Independence On Ramp		Independence Off Ramp	
Reports to Independence Mainline Toll Plaza			
Ramp Toll: E-PASS \$0.82 - CASH \$1.00			
*Changable Message Sign (CMS)			
Note: All CMS can display three messages: EXACT COINS, CHANGE RECEIPTS, E-PASS ONLY			

LEGEND

- <1 No. of Lanes
- ➔ Approach Lane Use
- Traffic Control
- Toll Plaza
- ## 2018 AAWT

RAMP DESCRIPTION

- A** NB On Ramp
- B** SB Off Ramp
- C** SB On Ramp
- D** NB Off Ramp

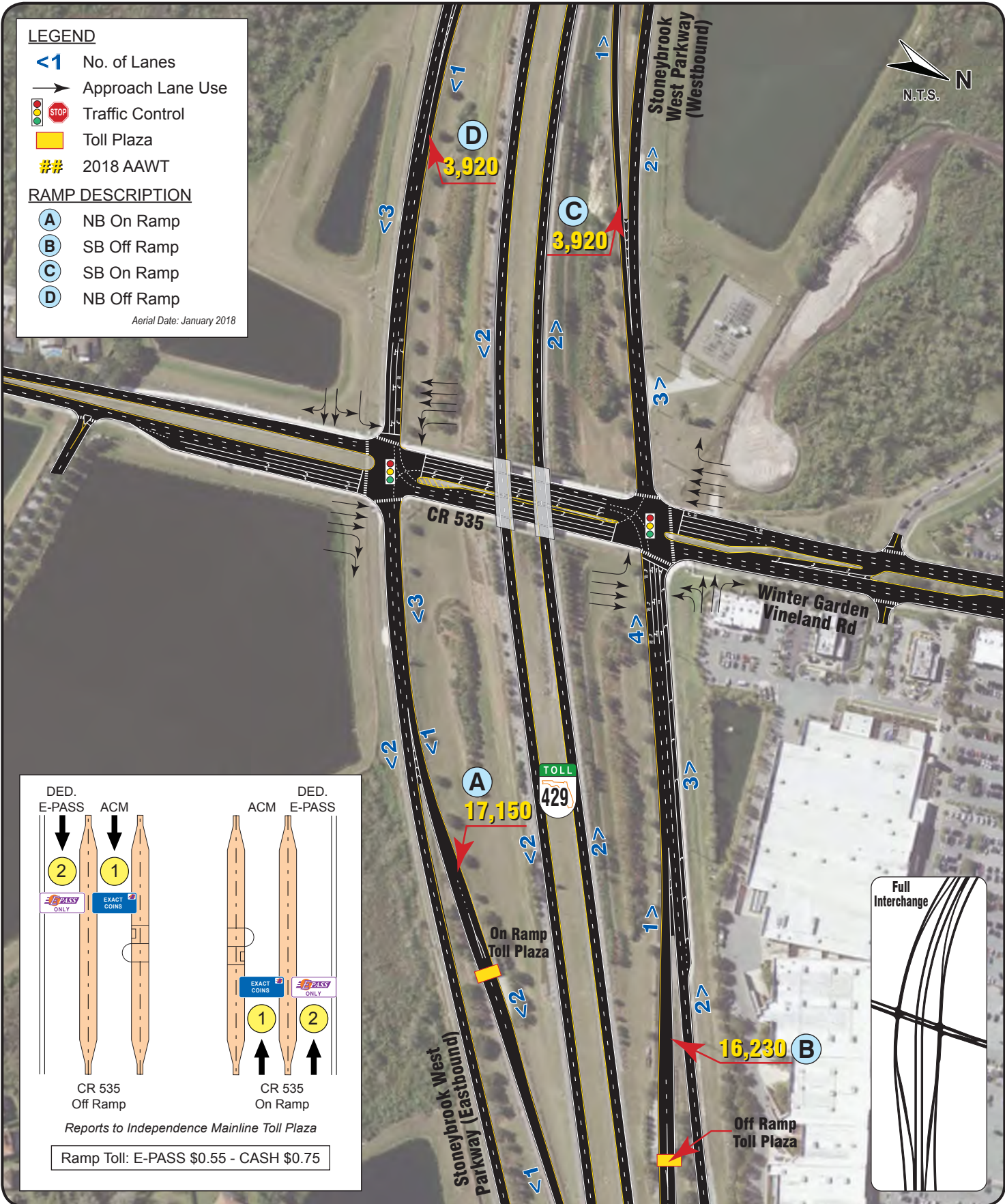

Aerial Date: January 2018



SR 429 (WESTERN BELTWAY)
Exit 19 - CR 535

SECTION IV

LEGEND

- <1 No. of Lanes
- Approach Lane Use
-  Traffic Control
-  Toll Plaza
- ## 2018 AAWT

RAMP DESCRIPTION

- (A) NB On from SR 50
- (B) SB Off to SR 50
- (C) SB Off to NB Turnpike
- (D) SB Off to SB Turnpike
- (E) NB On from SB Turnpike
- (F) NB On from NB Turnpike
- (G) SB On from SR 50
- (H) NB Off to SR 50
- (I) SB On from SB Turnpike
- (J) SB On from NB Turnpike
- (K) NB Off to SB Turnpike
- (L) NB Off to NB Turnpike

Aerial Date: January 2018

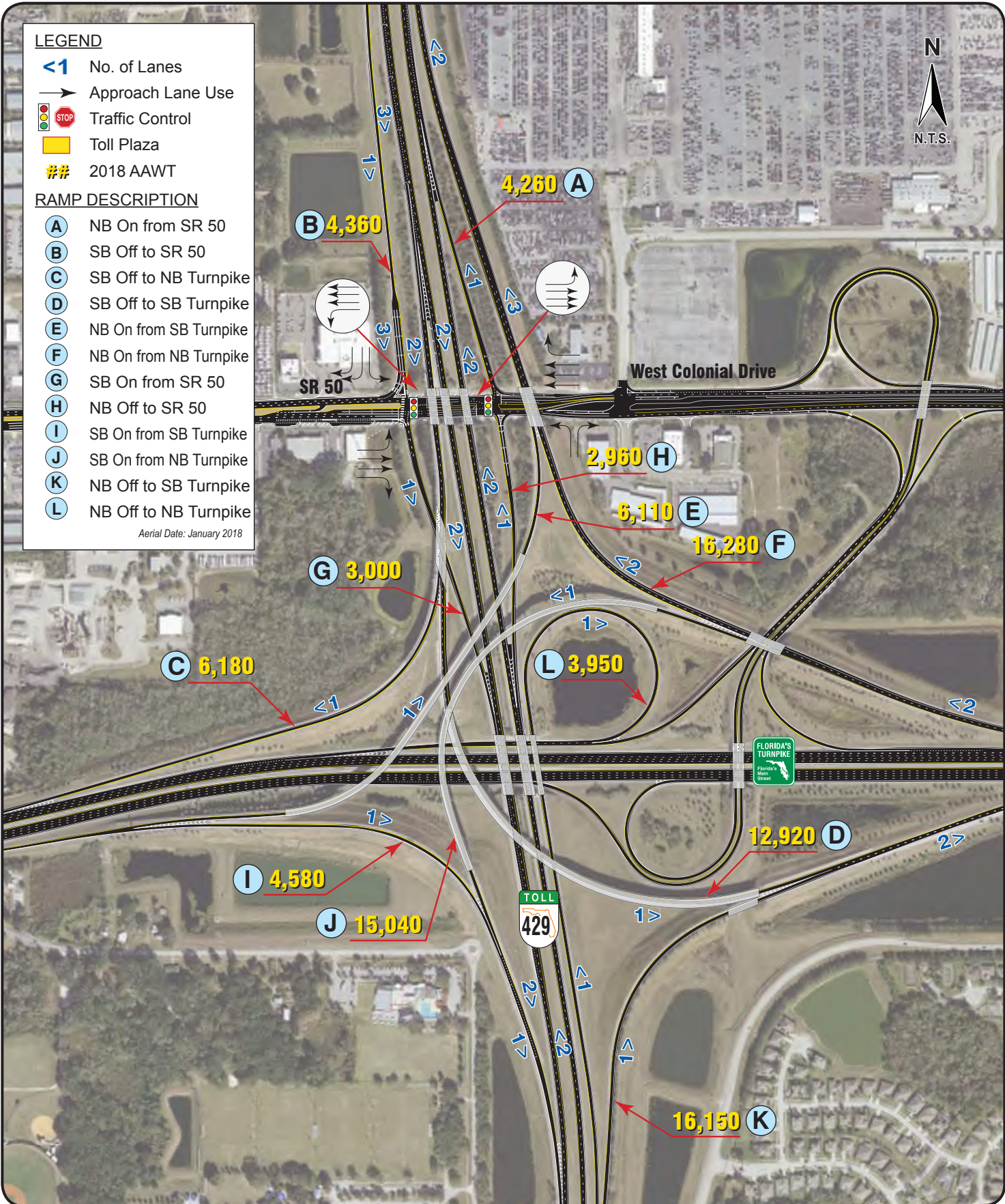

LEGEND

- <1 No. of Lanes
- Approach Lane Use
- Traffic Control
- Toll Plaza
- ## 2018 AAWT

RAMP DESCRIPTION

- (A)** SB On Ramp
- (B)** SB Off Ramp
- (C)** NB On Ramp
- (D)** NB Off Ramp

Aerial Date: January 2018

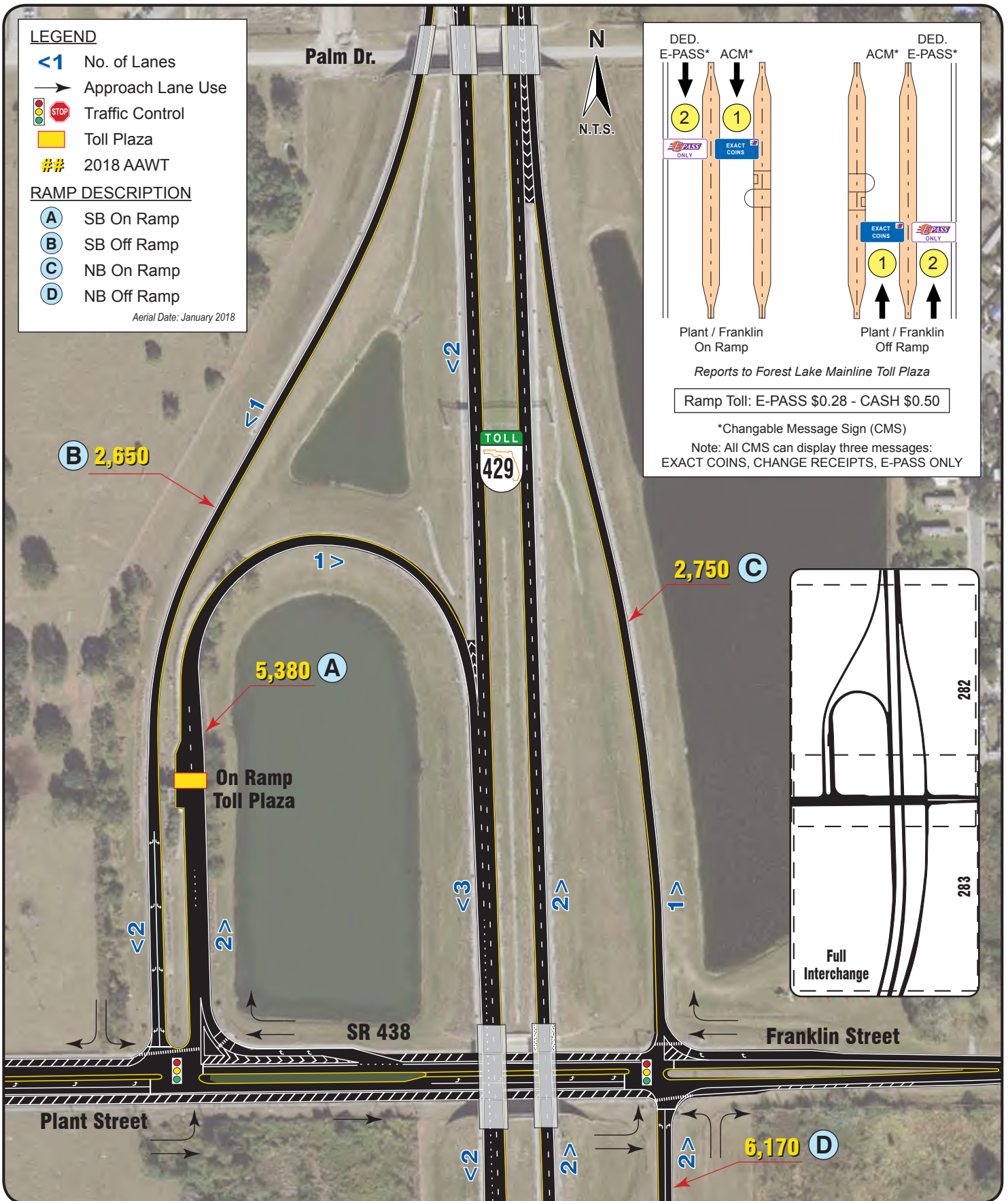

DED. E-PASS* ACM* DED. ACM* E-PASS*

Plant / Franklin On Ramp Plant / Franklin Off Ramp

Reports to Forest Lake Mainline Toll Plaza

Ramp Toll: E-PASS \$0.28 - CASH \$0.50

*Changable Message Sign (CMS)

Note: All CMS can display three messages: EXACT COINS, CHANGE RECEIPTS, E-PASS ONLY

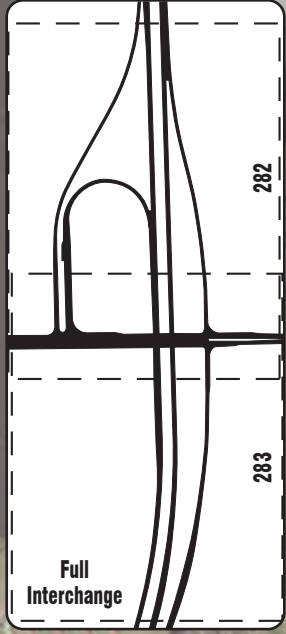

SR 429 (WESTERN BELTWAY)
Exit 24 - Plant Street/Franklin Street (SR 438)

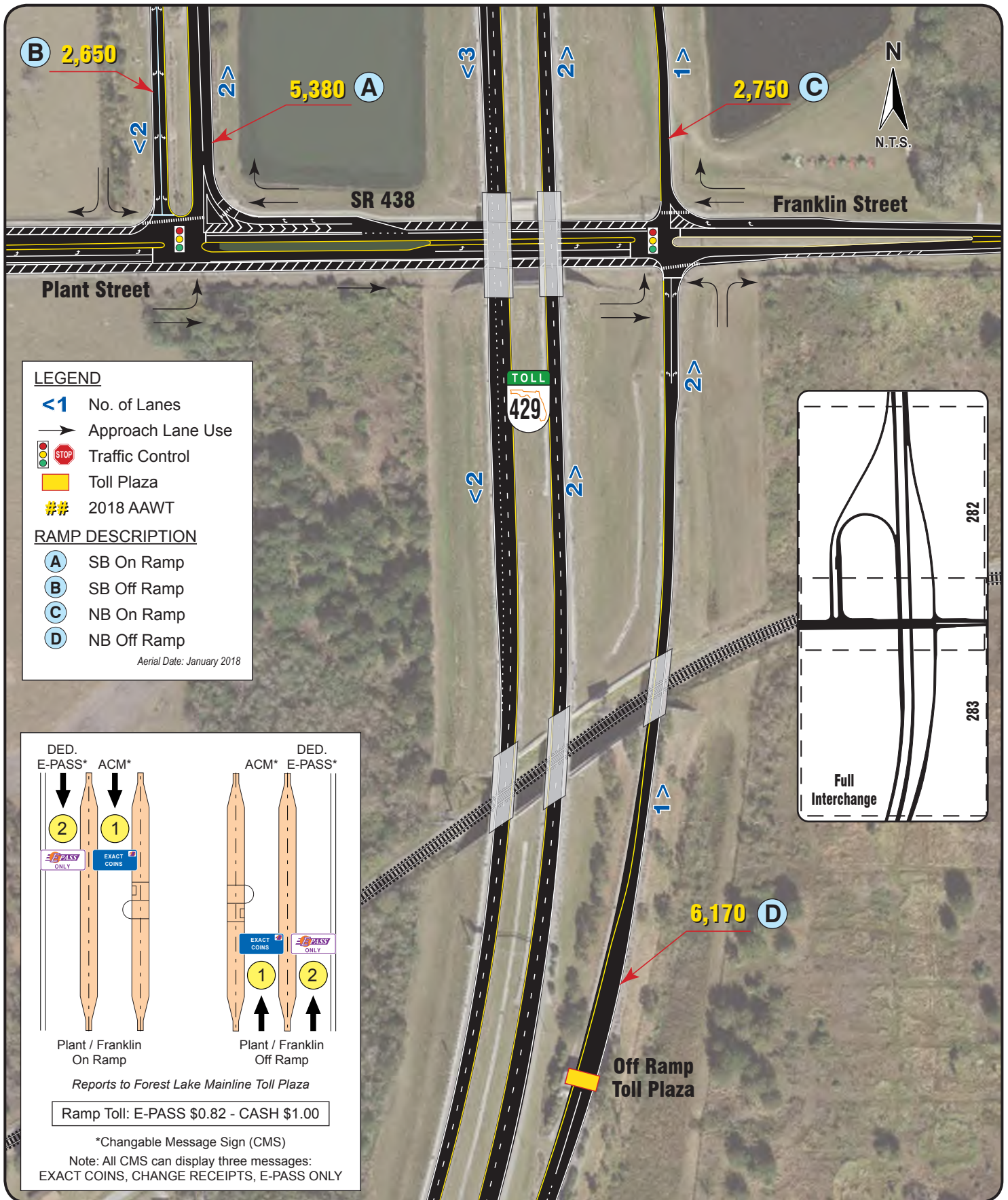

LEGEND

- <1 No. of Lanes
- Approach Lane Use
- STOP Traffic Control
- Yellow Box Toll Plaza
- ## 2018 AAWT

RAMP DESCRIPTION

- (A) SB On Ramp
- (B) SB Off Ramp
- (C) NB On Ramp
- (D) NB Off Ramp

Aerial Date: January 2018

<p>DED. E-PASS* ACM*</p> <p>Plant / Franklin On Ramp</p>	<p>ACM* DED. E-PASS*</p> <p>Plant / Franklin Off Ramp</p>
<p><i>Reports to Forest Lake Mainline Toll Plaza</i></p>	
<p>Ramp Toll: E-PASS \$0.82 - CASH \$1.00</p>	
<p>*Changable Message Sign (CMS) Note: All CMS can display three messages: EXACT COINS, CHANGE RECEIPTS, E-PASS ONLY</p>	

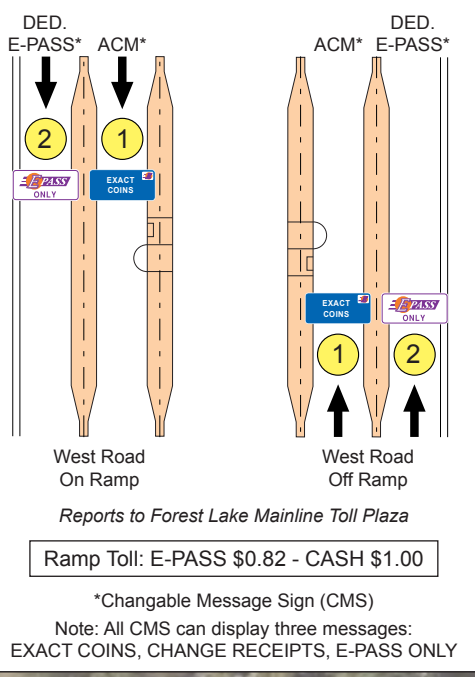

LEGEND

- <1 No. of Lanes
- Approach Lane Use
- STOP Traffic Control
- Yellow Box Toll Plaza
- ## 2018 AAWT

RAMP DESCRIPTION

- (A) SB Off Ramp
- (B) NB On Ramp
- (C) SB On Ramp
- (D) NB Off Ramp

Aerial Date: January 2018

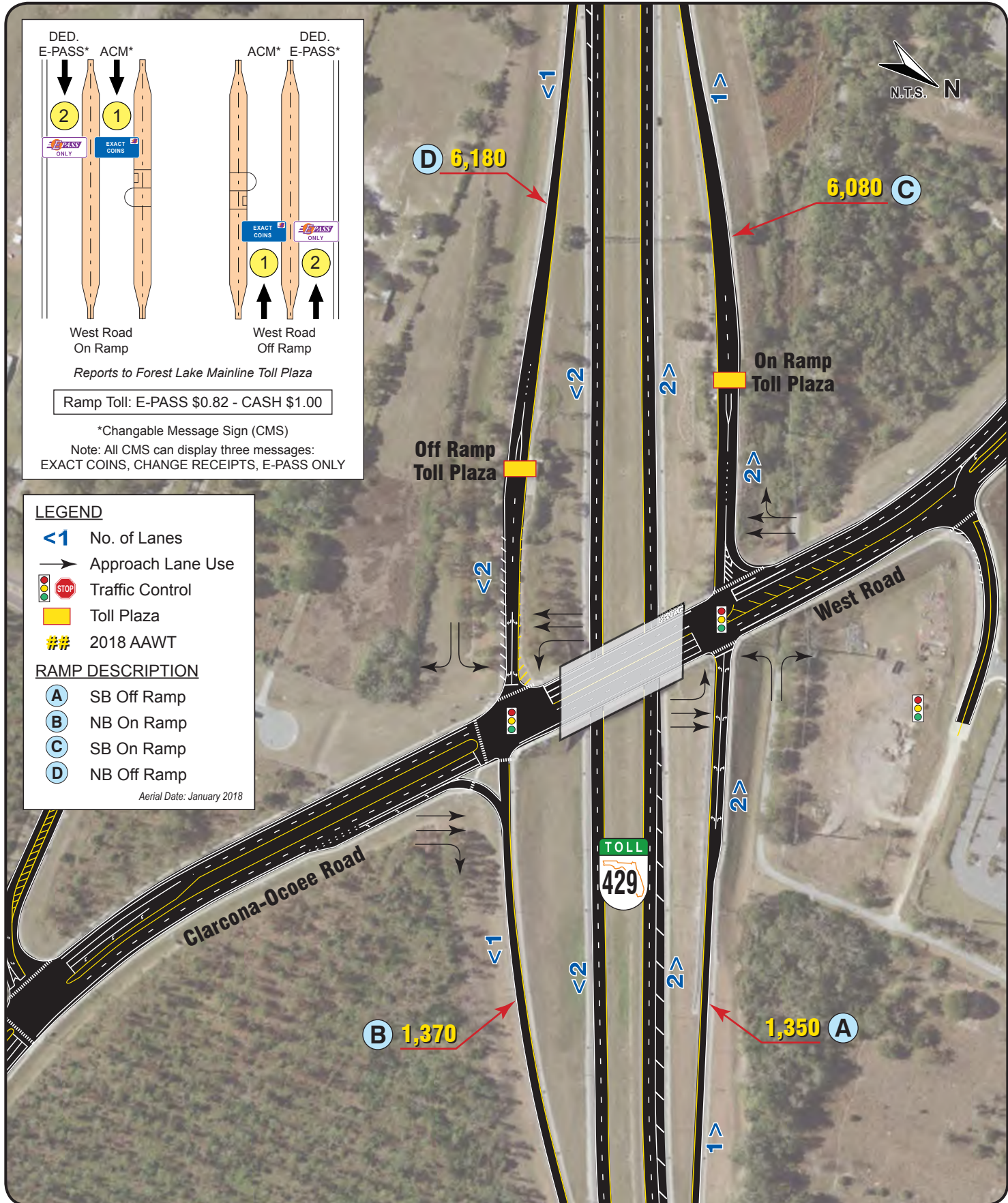

D 6,180

6,080 C

B 1,370



1,350 A



SR 429 (WESTERN BELTWAY)
Exit 26 - West Road/Clarcona-Ocoee Road

SECTION IV

LEGEND



- <1 No. of Lanes
- Approach Lane Use
-  Traffic Control
-  Toll Plaza
- ## 2018 AAWT

RAMP DESCRIPTION

- (A)** NB Off Ramp
- (B)** SB On Ramp
- (C)** NB On Ramp
- (D)** SB Off Ramp

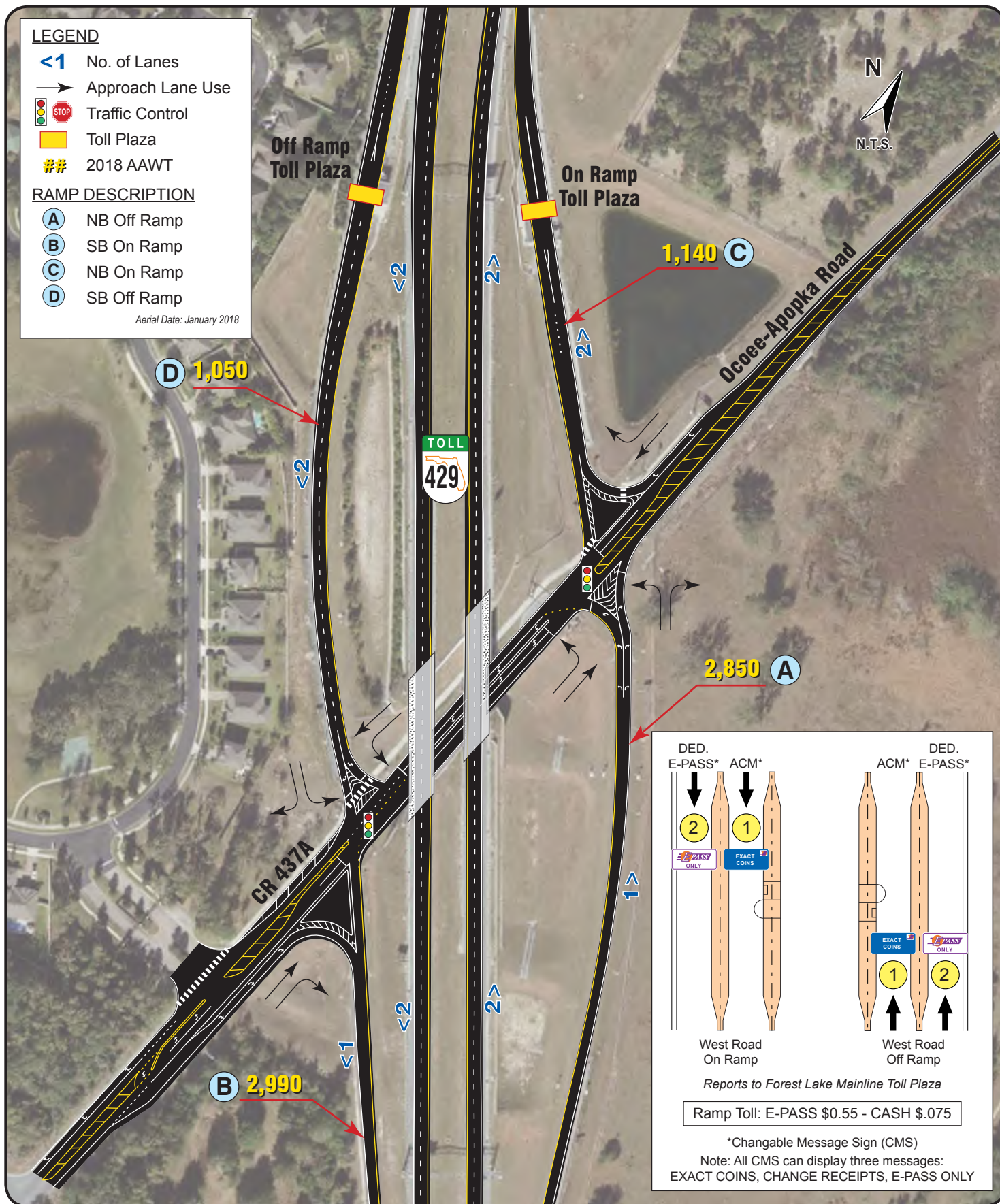
Aerial Date: January 2018

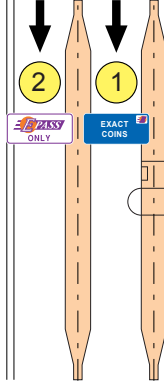

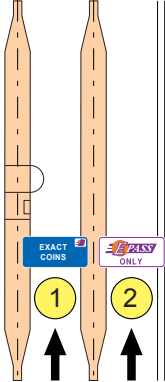
<p>DED. E-PASS*</p>  <p>West Road On Ramp</p>	<p>ACM*</p> 	<p>DED. ACM*</p>  <p>West Road Off Ramp</p>
<p>Reports to Forest Lake Mainline Toll Plaza</p>		
<p>Ramp Toll: E-PASS \$0.55 - CASH \$0.075</p>		
<p>*Changable Message Sign (CMS)</p> <p>Note: All CMS can display three messages: EXACT COINS, CHANGE RECEIPTS, E-PASS ONLY</p>		



SR 429 (WESTERN BELTWAY)
Exit 29 - Ocoee-Apopka Road (CR 437A)

SECTION IV

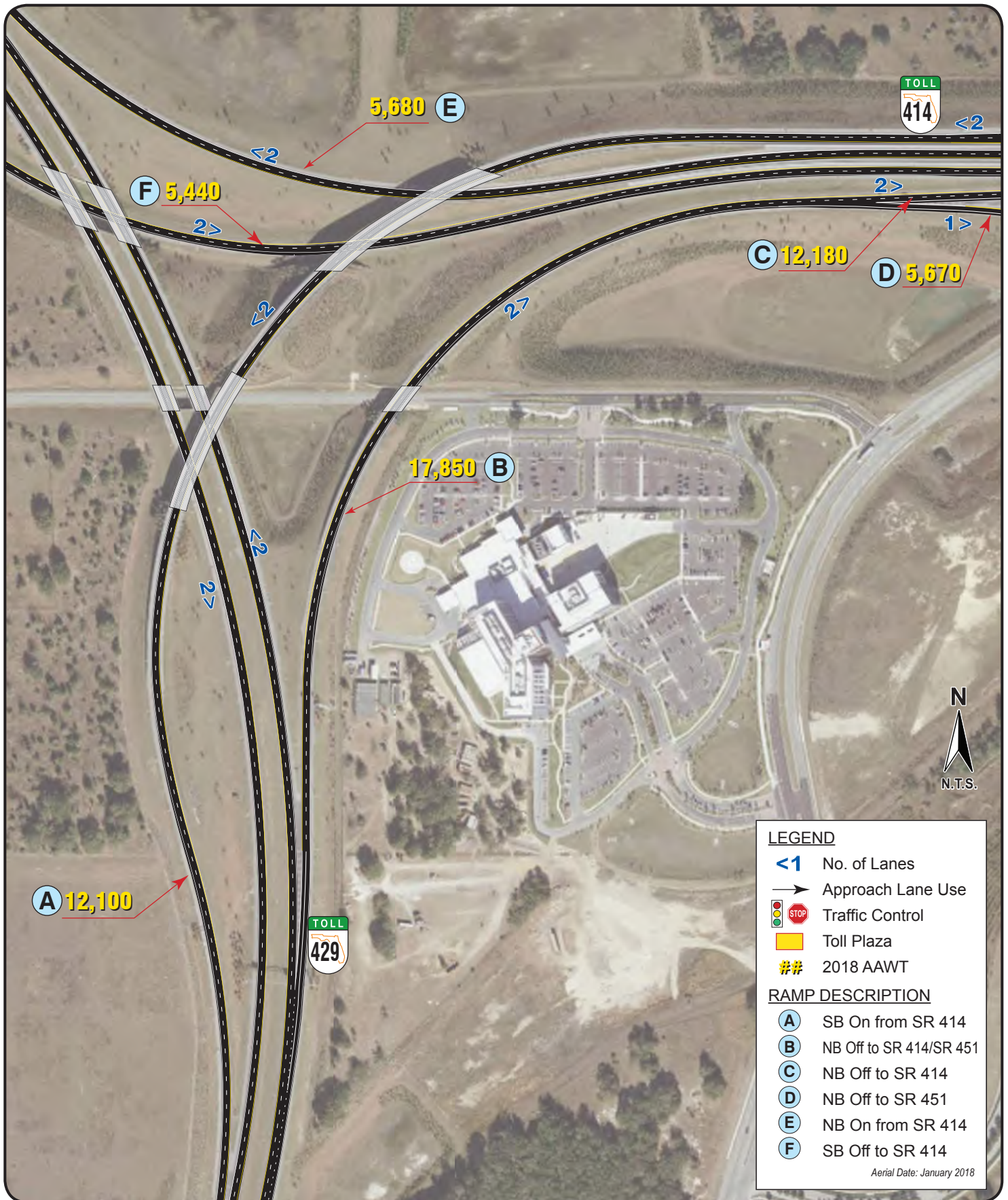

LEGEND

- <1 Approach Lane Use
- Approach Lane Use
- ⚡ Traffic Control
- 🟡 Toll Plaza
- ## 2018 AAWT

RAMP DESCRIPTION

- A** SB On from SR 414
- B** NB Off to SR 414/SR 451
- C** NB Off to SR 414
- D** NB Off to SR 451
- E** NB On from SR 414
- F** SB Off to SR 414

Aerial Date: January 2018



LEGEND

- <1> No. of Lanes
- Approach Lane Use
- Traffic Control
- Toll Plaza
- ## 2018 AAWT

RAMP DESCRIPTION

- NB Off Ramp
- SB On Ramp
- SB Off Ramp
- NB On Ramp

Aerial Date: January 2018



SR 429 (WESTERN BELTWAY)
Exit 34 - SR 429/SR 414 at US 441/Connector Road/CR 437

SECTION IV



LEGEND

- <1 No. of Lanes
- Approach Lane Use
- 🚦 Traffic Control
- 🟡 Toll Plaza
- ## 2018 AAWT

RAMP DESCRIPTION

- (A) NB Off Ramp
- (B) SB On Ramp
- (C) NB On Ramp
- (D) SB On Ramp
- (E) NB On Loop Ramp

Aerial Date: January 2018



**SR 429 (WEKIVA PARKWAY)
Exit 38 - Kelly Park Road Interchange**

SECTION IV

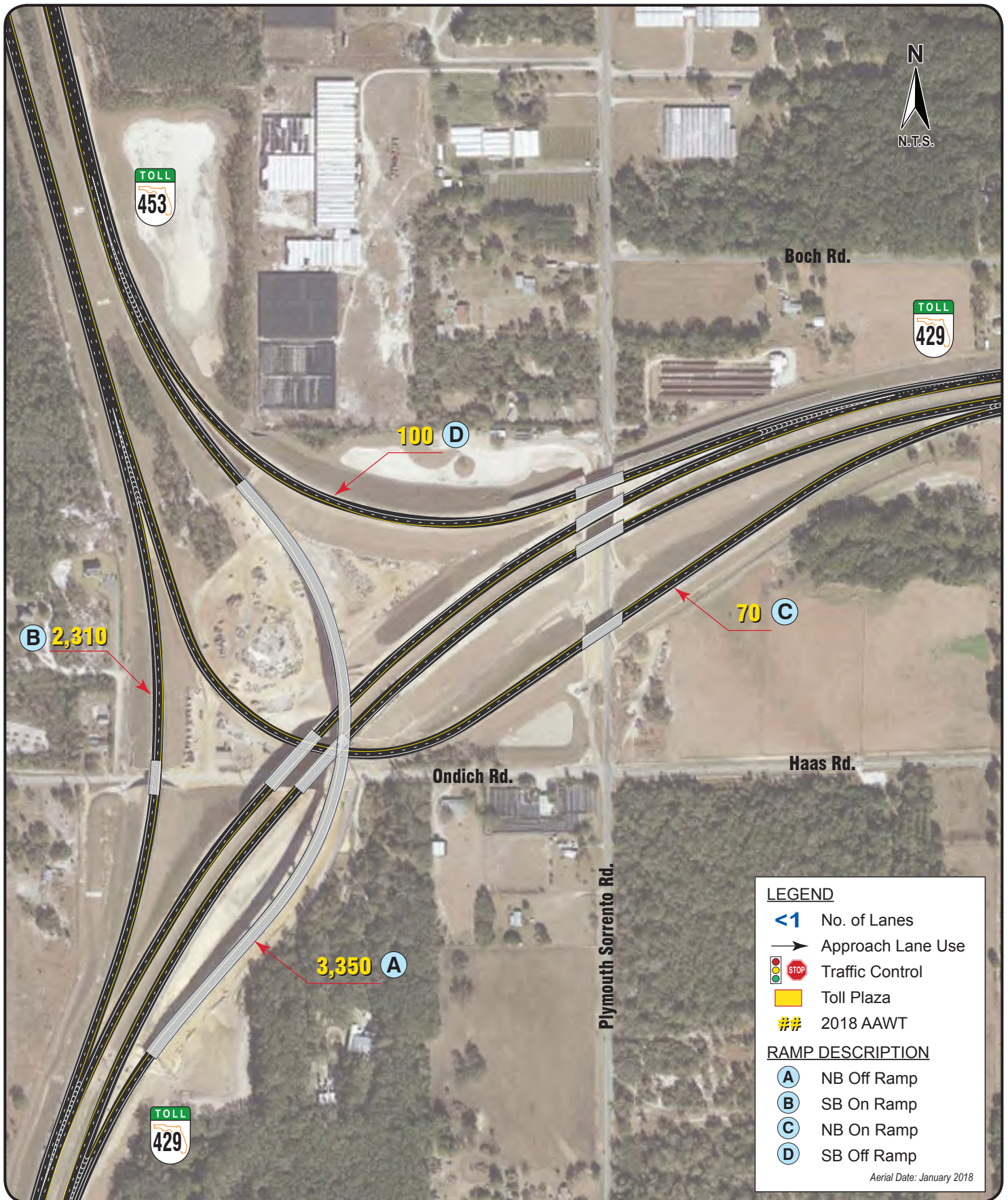

LEGEND

- <1 No. of Lanes
- Approach Lane Use
- 🚦 STOP Traffic Control
- 🟡 Toll Plaza
- ## 2018 AAWT

RAMP DESCRIPTION

- (A) NB Off Ramp
- (B) SB On Ramp
- (C) NB On Ramp
- (D) SB Off Ramp

Aerial Date: January 2018



**SR 429 (WEKIVA PARKWAY)
Exit 39 - Wekiva Parkway (SR 453)**

SECTION IV

Apopka Expressway



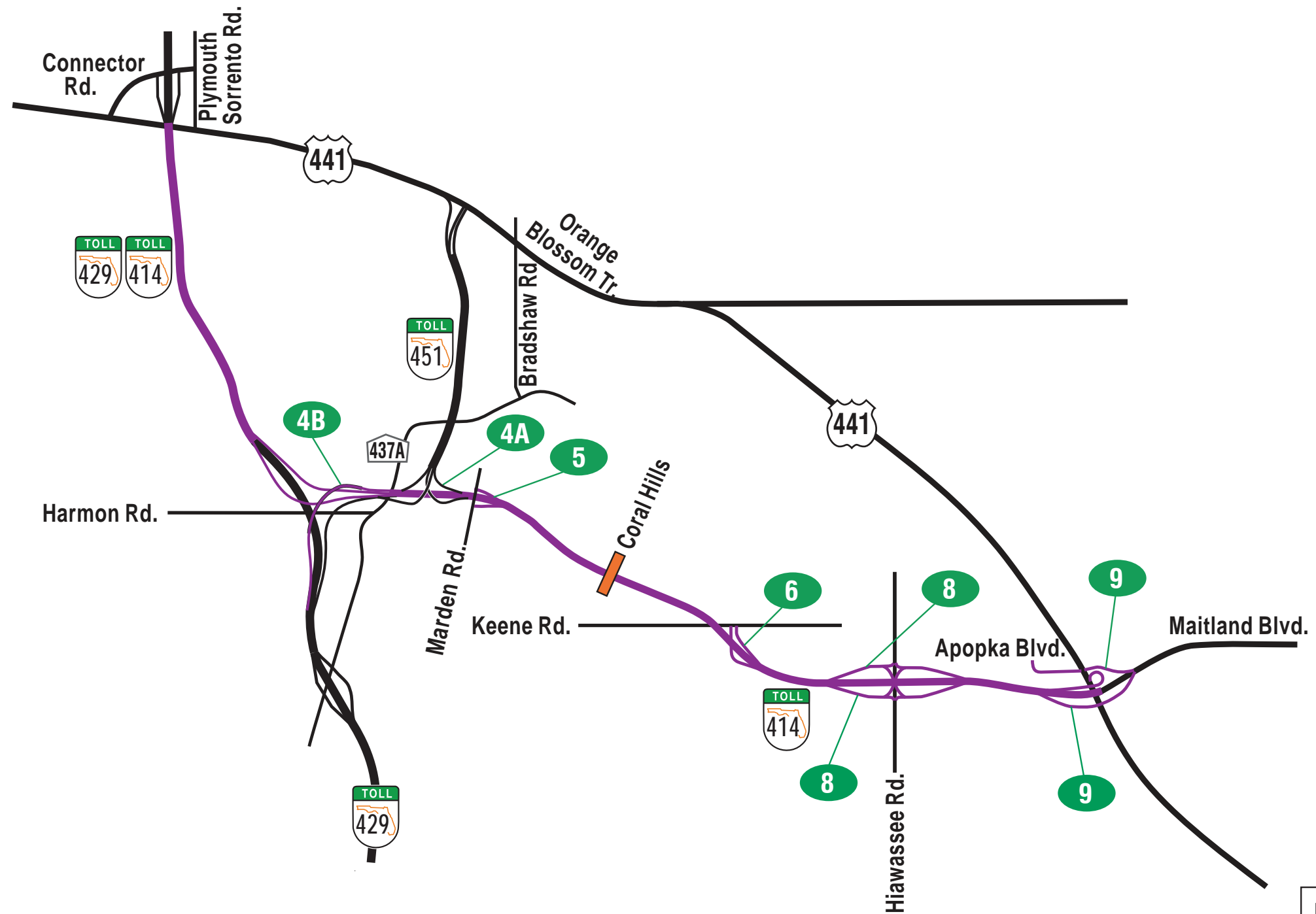



LEGEND

- Exit Number
- Existing SR 414
- Mainline Toll Plaza

LEGEND

- <1 No. of Lanes
- ➔ Approach Lane Use
-  Traffic Control
-  Toll Plaza
- ## 2018 AAWT

RAMP DESCRIPTION

- A** SB Off to EB SR 414
- B** NB On from SR 429
- C** SB Off to SR 429
- D** WB On from SB SR 451
- E** EB On from NB SR 429
- F** WB Off to SB SR 429

Aerial Date: January 2018

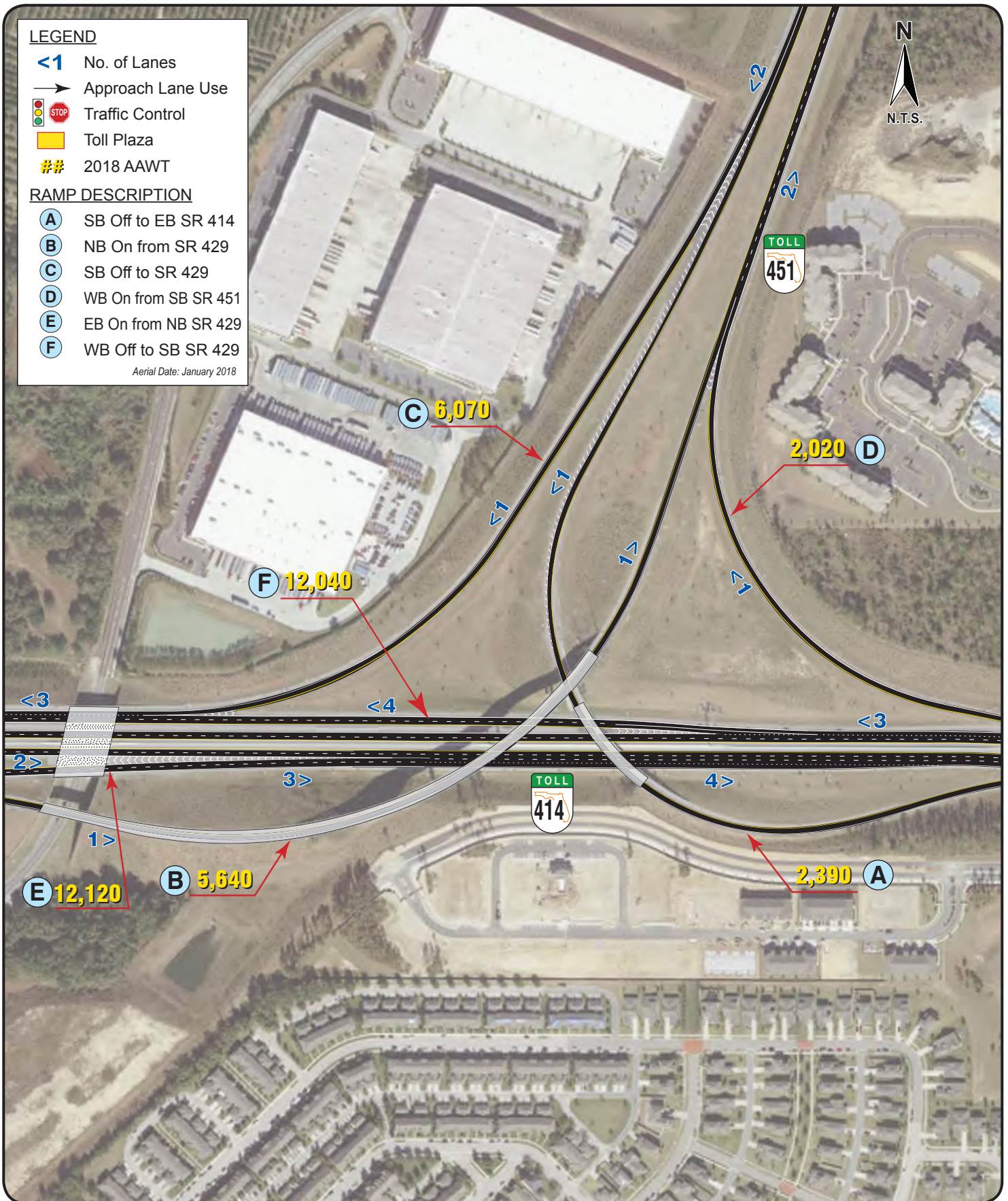

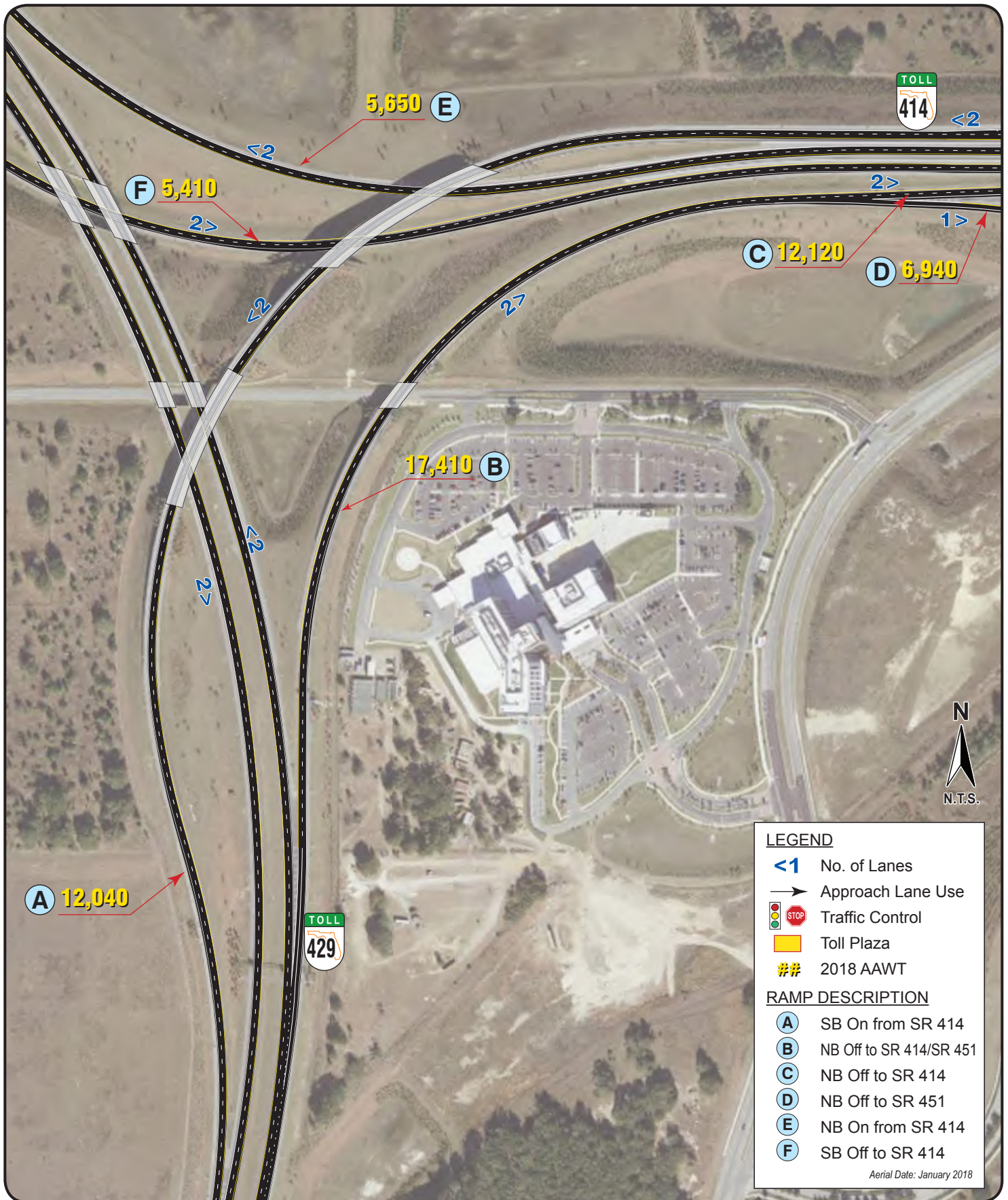

LEGEND

- <1 No. of Lanes
- Approach Lane Use
- Traffic Control
- Toll Plaza
- ##** 2018 AAWT

RAMP DESCRIPTION

- (A)** SB On from SR 414
- (B)** NB Off to SR 414/SR 451
- (C)** NB Off to SR 414
- (D)** NB Off to SR 451
- (E)** NB On from SR 414
- (F)** SB Off to SR 414

Aerial Date: January 2018



**SR 414 (APOPKA EXPRESSWAY)
Exit 4B - Western Beltway (SR 429)**

SECTION IV

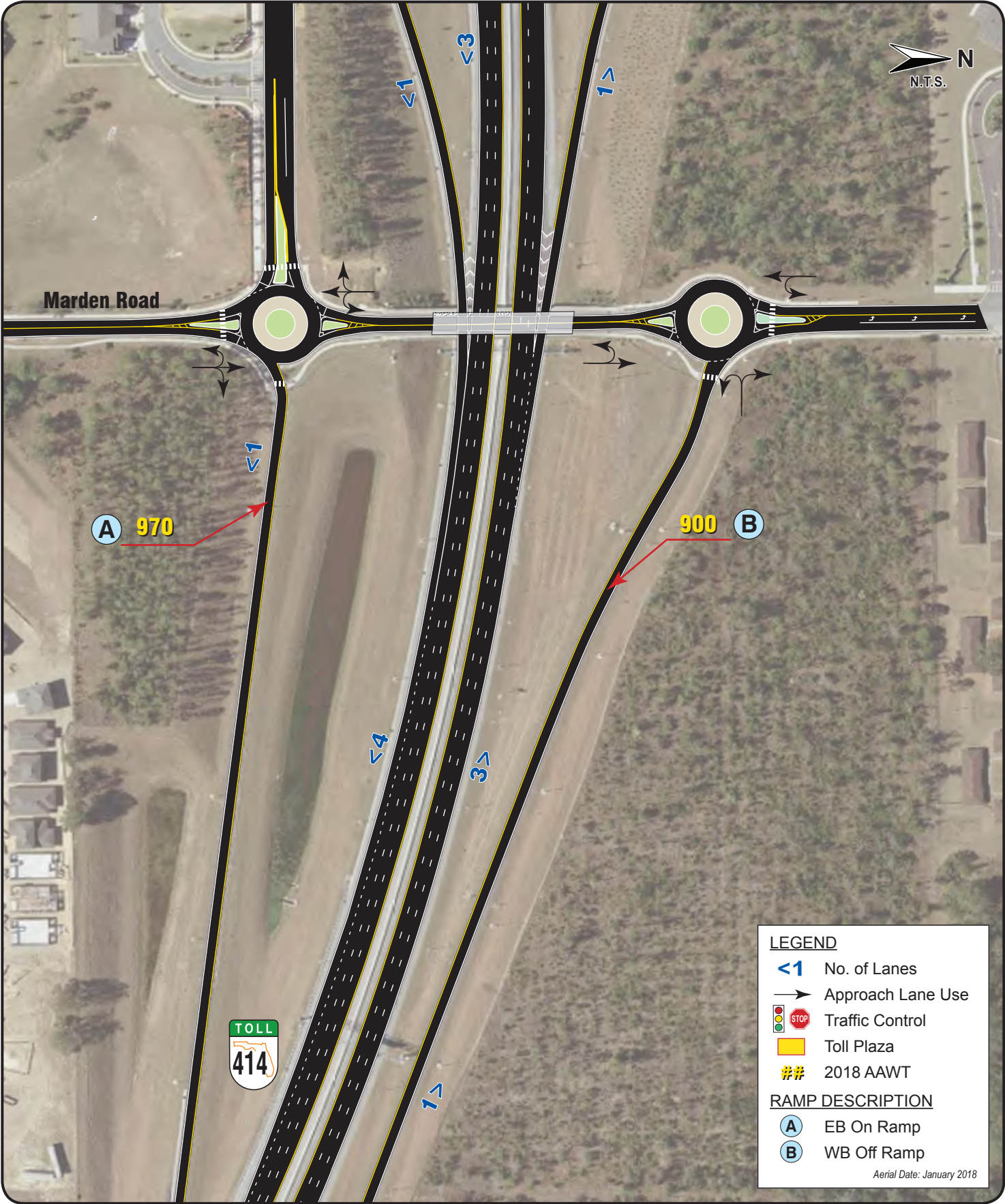

Marden Road

A 970

900 B



LEGEND

- <1 No. of Lanes
- Approach Lane Use
- ⬛ STOP Traffic Control
- 🟡 Toll Plaza
- ## 2018 AAWT

RAMP DESCRIPTION

- A EB On Ramp
- B WB Off Ramp

Aerial Date: January 2018

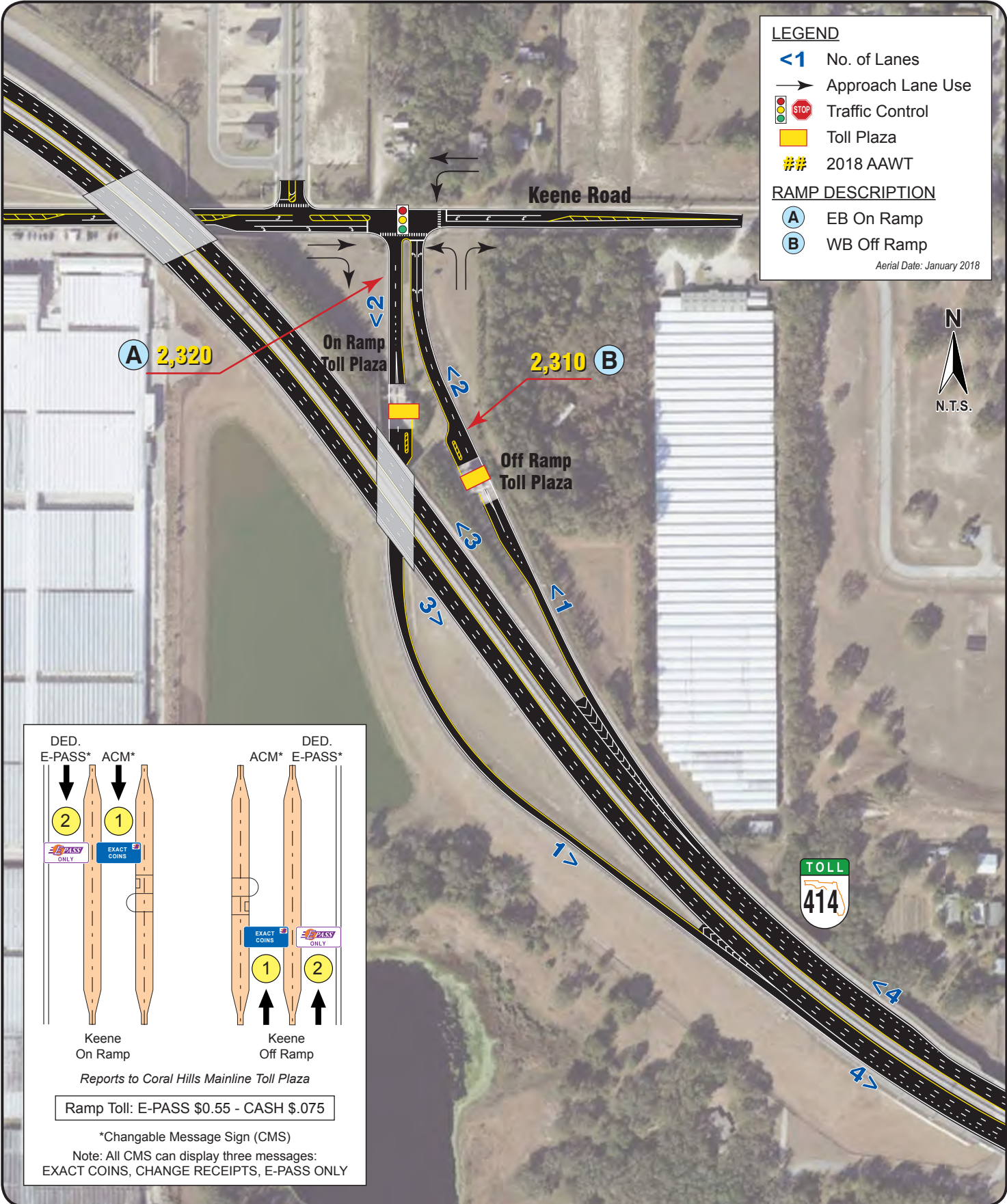

LEGEND

- <1 No. of Lanes
- Approach Lane Use
- Traffic Control
- Toll Plaza
- ##** 2018 AAWT

RAMP DESCRIPTION

- A EB On Ramp
- B WB Off Ramp

Aerial Date: January 2018



<p>DED. E-PASS* ACM*</p> <p>Keene On Ramp</p>	<p>ACM* DED. E-PASS*</p> <p>Keene Off Ramp</p>
<p><i>Reports to Coral Hills Mainline Toll Plaza</i></p>	
<p>Ramp Toll: E-PASS \$0.55 - CASH \$0.75</p>	
<p>*Changable Message Sign (CMS)</p> <p>Note: All CMS can display three messages: EXACT COINS, CHANGE RECEIPTS, E-PASS ONLY</p>	



SR 414 (APOPKA EXPRESSWAY)
Exit 6 - Keene Road

SECTION IV

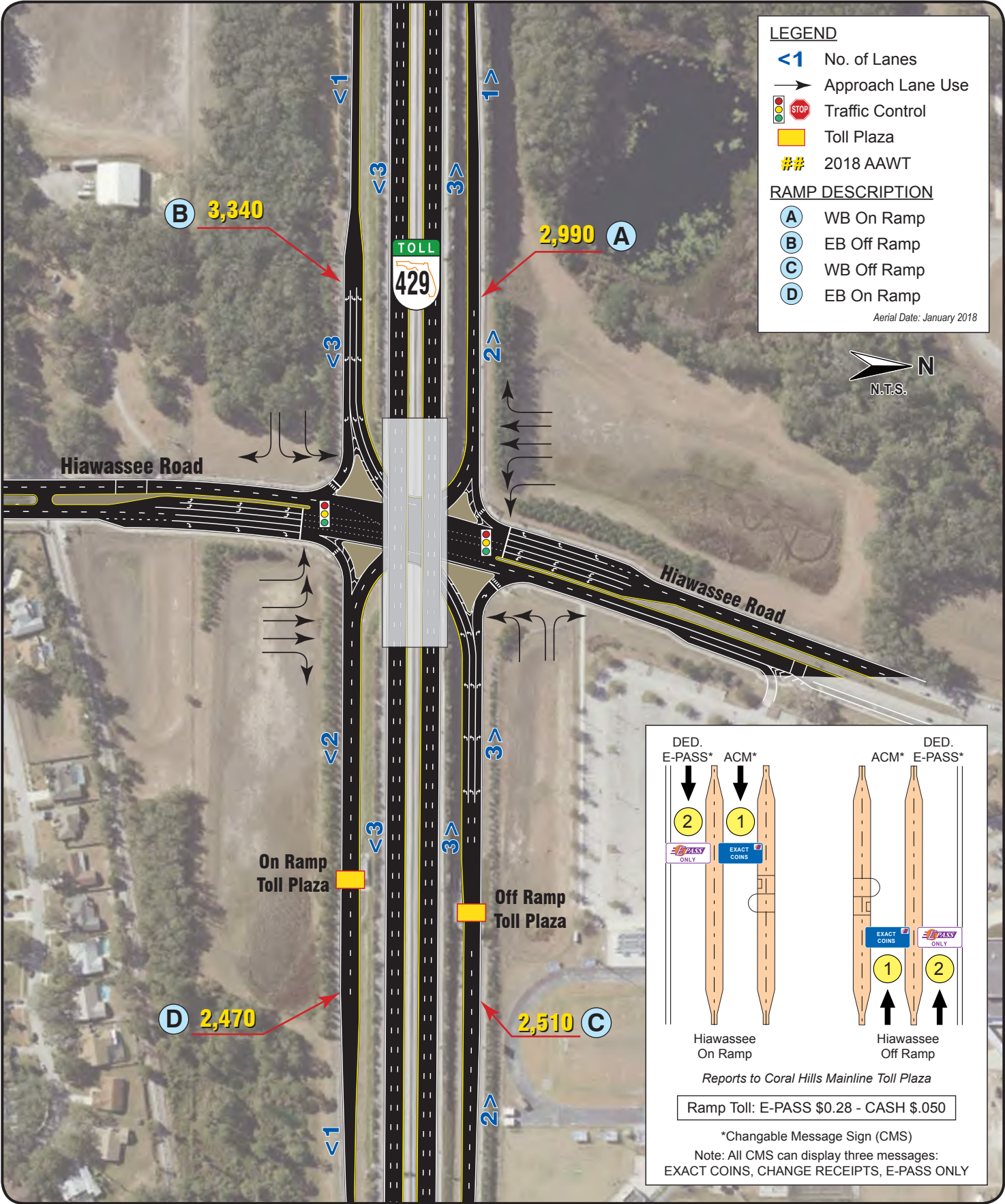

LEGEND

- <1 No. of Lanes
- Approach Lane Use
- STOP Traffic Control
- Toll Plaza
- ## 2018 AAWT

RAMP DESCRIPTION

- A WB On Ramp
- B EB Off Ramp
- C WB Off Ramp
- D EB On Ramp

Aerial Date: January 2018



DED. E-PASS*	ACM*	ACM*	DED. E-PASS*
2	1	1	2
EXACT COINS ONLY	EXACT COINS	EXACT COINS	EXACT COINS ONLY
Hiawassee On Ramp		Hiawassee Off Ramp	
Reports to Coral Hills Mainline Toll Plaza			
Ramp Toll: E-PASS \$0.28 - CASH \$0.050			
*Changable Message Sign (CMS)			
Note: All CMS can display three messages: EXACT COINS, CHANGE RECEIPTS, E-PASS ONLY			



**SR 414 (APOPKA EXPRESSWAY)
Exit 8 - Hiawassee Road**

SECTION IV

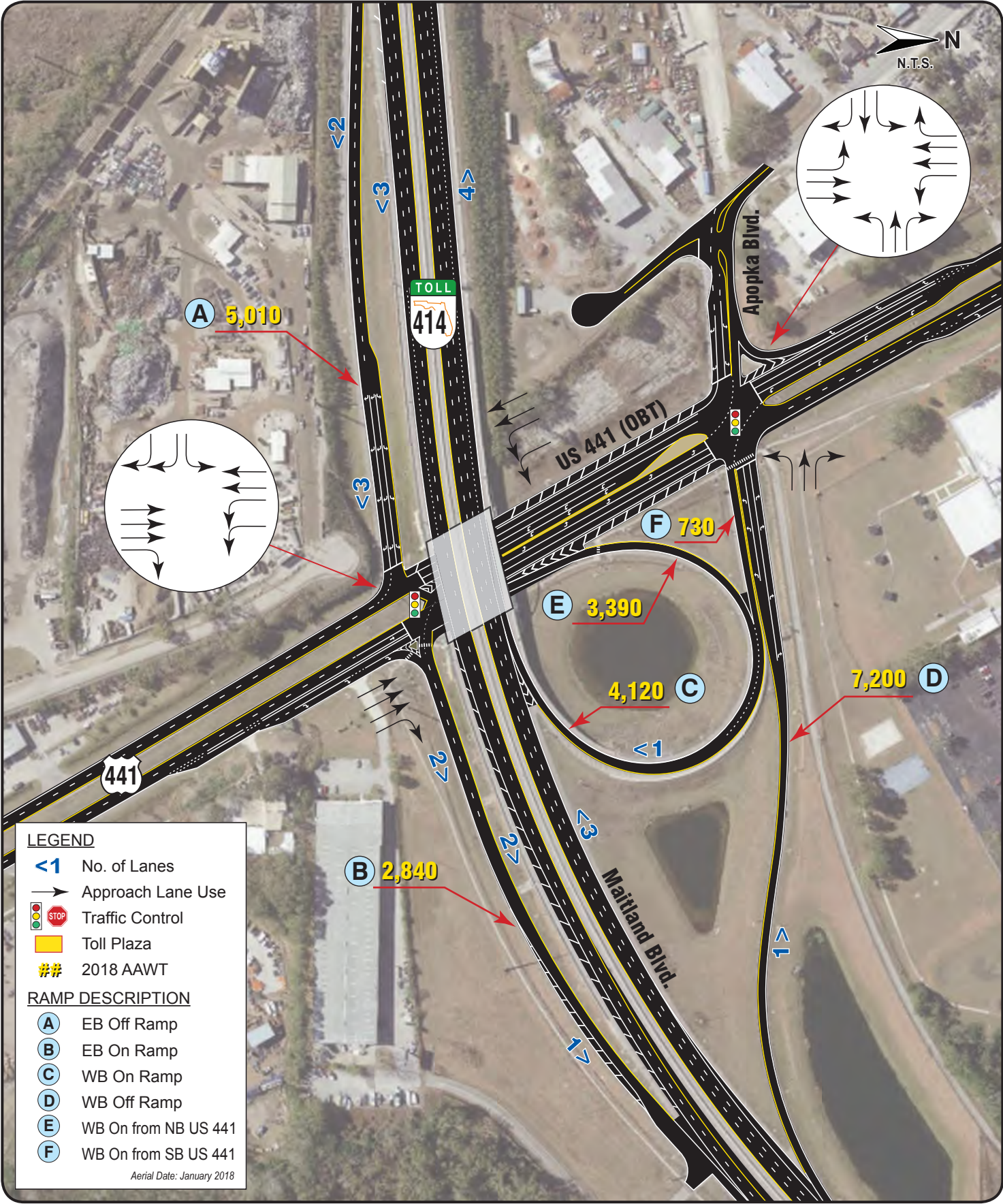

LEGEND

- <1 No. of Lanes
- Approach Lane Use
- 🚦 Traffic Control
- 🛑 STOP
- 🟡 Toll Plaza
- ## 2018 AAWT

RAMP DESCRIPTION

- (A) EB Off Ramp
- (B) EB On Ramp
- (C) WB On Ramp
- (D) WB Off Ramp
- (E) WB On from NB US 441
- (F) WB On from SB US 441

Aerial Date: January 2018





SR 414 (APOPKA EXPRESSWAY)
Exit 9 - Orange Blossom Trail (US 441)

Western Beltway Connector Road

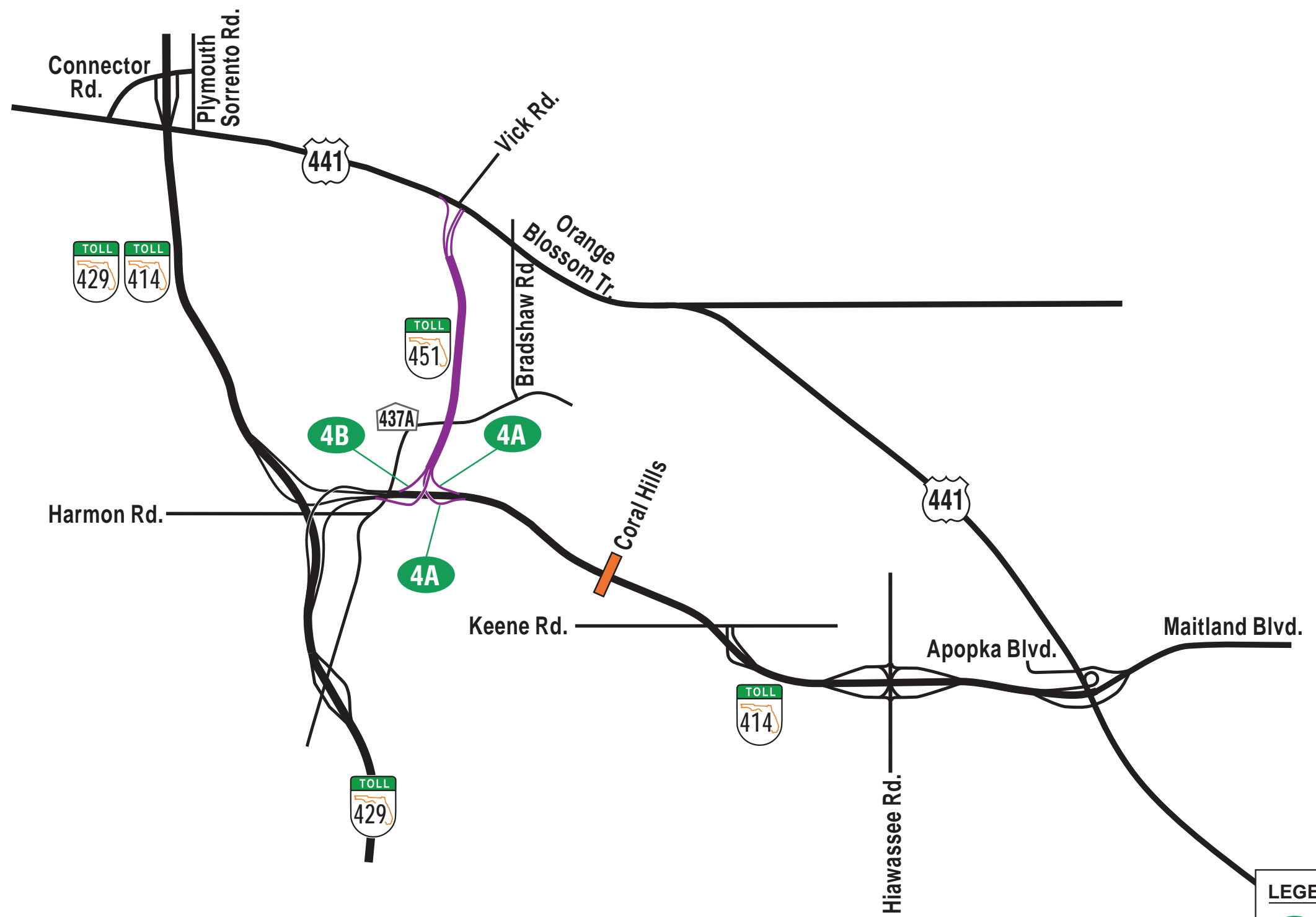



LEGEND

-  Exit Number
-  Existing SR 451
-  Mainline Toll Plaza



SR 451 - WESTERN BELTWAY CONNECTOR ROAD
Exit Numbers

LEGEND

- <1 No. of Lanes
- Approach Lane Use
-  Traffic Control
-  Toll Plaza
- ## 2018 AAWT

RAMP DESCRIPTION

- A** SB Off to EB SR 414
- B** NB On from SR 429
- C** SB Off to SR 429
- D** NB On from WB SR 414
- E** EB On from NB SR 429
- F** WB Off to SB SR 429

Aerial Date: January 2018

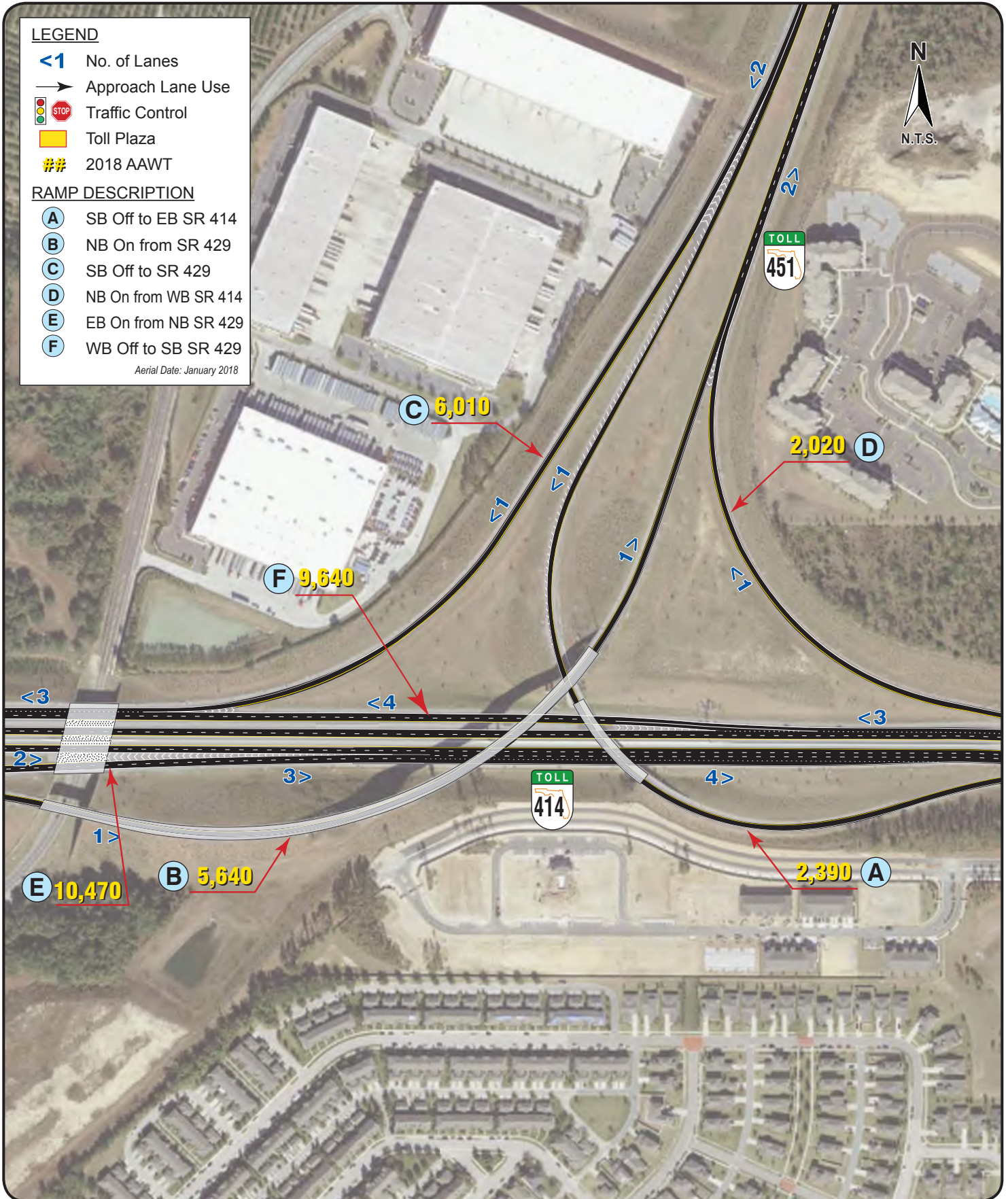

SR 451 (WESTERN BELTWAY CONNECTOR ROAD)
Exit 4A/4B - SR 414 East/SR 429 South

SECTION IV

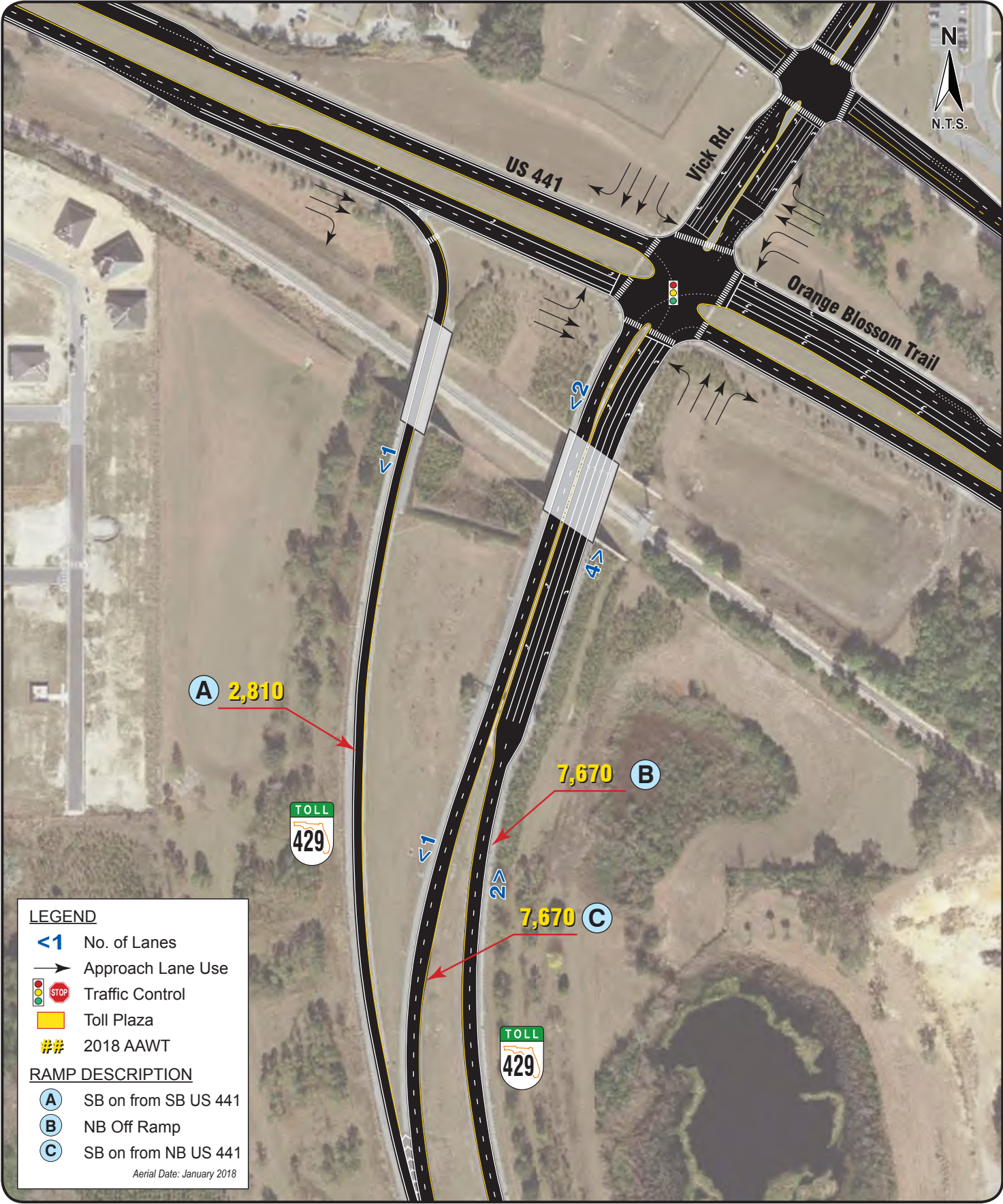

LEGEND

- <1 No. of Lanes
- Approach Lane Use
- ⬆️ Traffic Control
- ▭ Toll Plaza
- ## 2018 AAWT

RAMP DESCRIPTION

- (A) SB on from SB US 441
- (B) NB Off Ramp
- (C) SB on from NB US 441

Aerial Date: January 2018



**SR 451 (WESTERN BELTWAY CONNECTOR ROAD)
Exit 33 - Orange Blossom Trail (US 441)**

SR 453



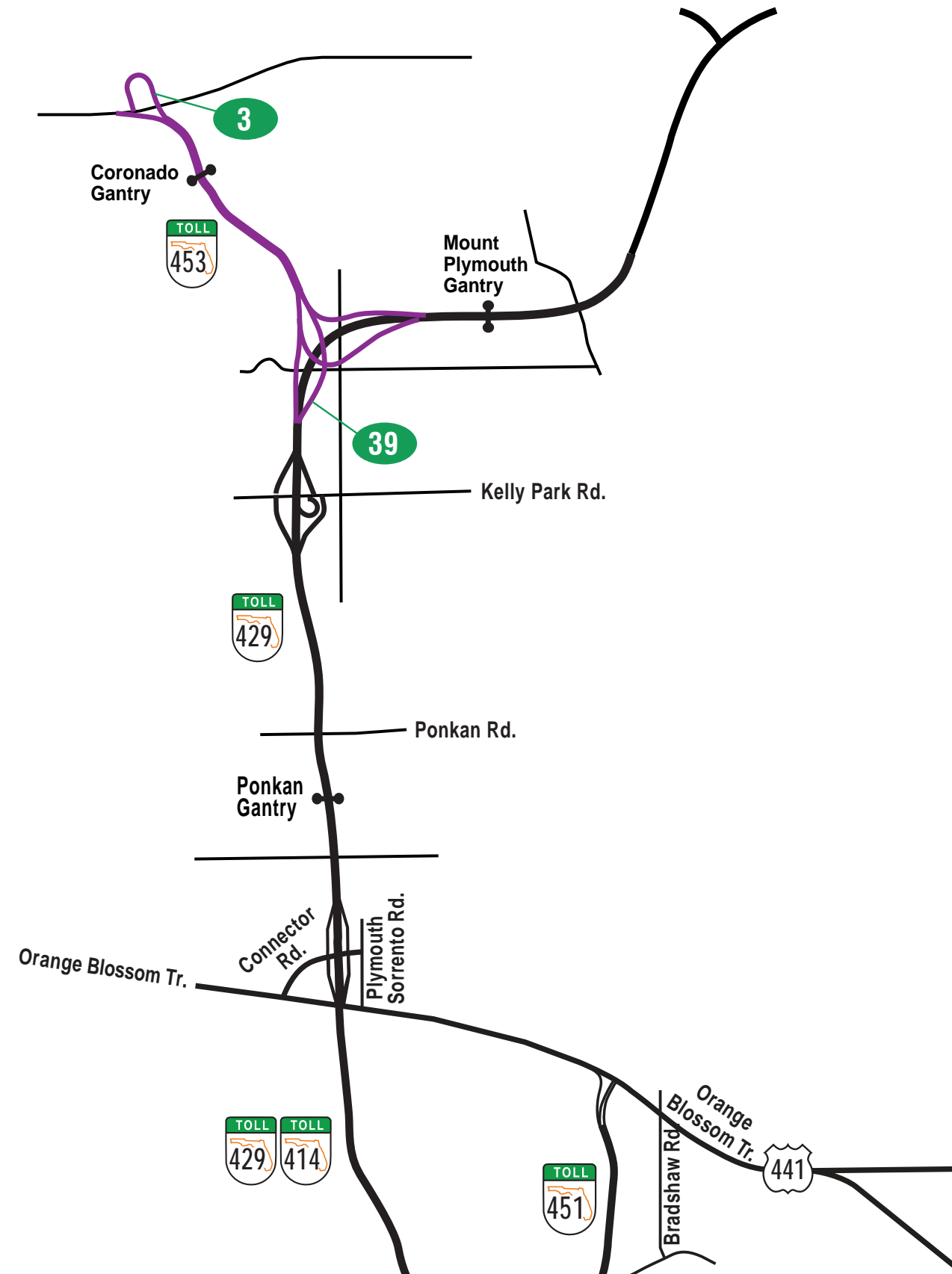

LEGEND

- Exit Number
- Existing SR 453
- Mainline Toll Plaza
- Mainline Toll Gantry

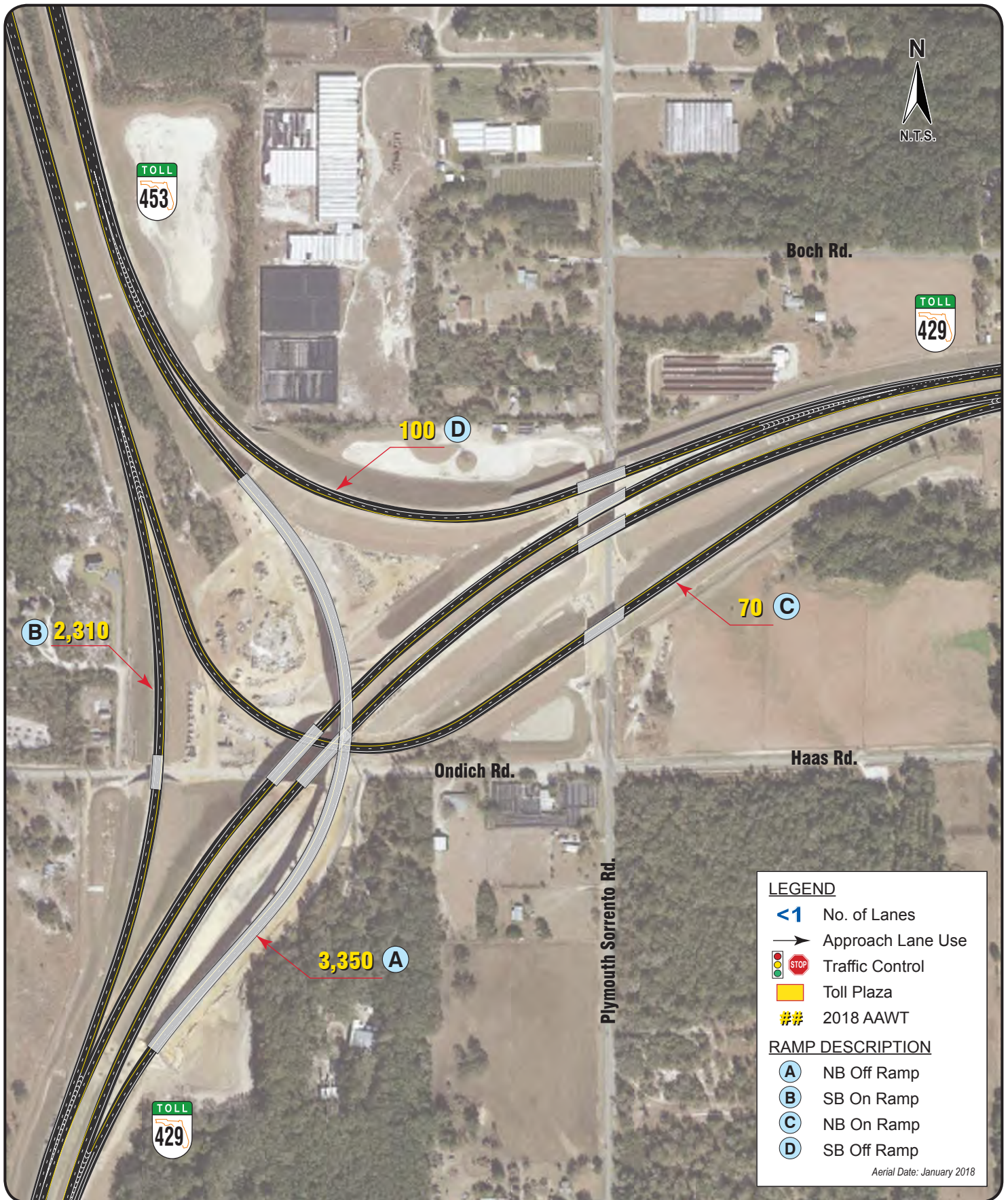

SR 453
Exit 39 - SR 429 (Western Beltway and Wekiva Parkway)

SECTION IV

304



LEGEND

- <1 No. of Lanes
- Approach Lane Use
- Traffic Control
- Toll Plaza
- ## 2018 AAWT

RAMP DESCRIPTION

- A NB Off Ramp
- B SB On Ramp

Aerial Date: January 2018



SR 453
Exit 3 - SR 453 at SR 46

SECTION IV

305



Section V: General Statistics



2018 Traffic Data and Statistics Manual
CENTRAL FLORIDA EXPRESSWAY AUTHORITY

General Statistics Introduction

This section of the manual is a summary of the general statistics that have been gathered on the Central Florida Expressway Authority's system. Data is included for SR 408 (East-West Expressway), SR 528 (Beachline Expressway), SR 417 (Central Florida GreeneWay), SR 429 (Daniel Webster Western Beltway and Wekiva Parkway), SR 451 (Western Connector), SR 414 (Apopka Expressway), SR 453, and the non-system Goldenrod Extension. The information contained in this section is shown below:

- Expressway Total Centerline Mileage and Total Lane Miles for SR 408, SR 528, SR 417, SR 429, SR 451, SR 414, SR 453 and the Goldenrod Extension.
- Toll Plaza Lane Summary for SR 408, SR 528, SR 417, SR 429, SR 414, SR 453 and the Goldenrod Extension.
- Toll Rate Schedule for all mainline and ramp toll plazas based on the number of axles.
- Distance between interchanges for SR 408, SR 528, SR 417, SR 429, SR 414, and SR 453 (Centerline of Crossroad to Centerline of Crossroad).
- Toll Rates and/or Toll Costs between interchanges on SR 408, SR 528, SR 417, SR 429, SR 414, and SR 453.
- Toll Cost per Mile between interchanges on SR 408, SR 528, SR 417, SR 429, SR 414, and SR 453.

Wekiva Phase II was opened to traffic on March 31, 2018 and is included for informational purposes.

Expressway Mileage, Lane Miles, Toll Plaza Lanes and Toll Rate Schedules



2018 Traffic Data and Statistics Manual
CENTRAL FLORIDA EXPRESSWAY AUTHORITY

Central Florida Expressway Authority (CFX)

Expressway Mileage

CFX Expressway Facility	Rounded Miles	Total Length ⁽¹⁾	
		Miles	Kilometers
Central Florida Expressway System			
SR 408 (East-West Expressway)	22	21.477	34.564
SR 528 (Beachline Expressway)	23	22.405	36.057
SR 417 (Central Florida GreeneWay)	32	31.613	50.876
SR 429 (Western Beltway and Wekiva Parkway)	31	30.848	49.645
SR 451 (Western Beltway Connector Road) ⁽²⁾	2	1.670	2.688
SR 414 (Apopka Expressway)	6	6.024	9.695
SR 453	2	1.983	3.191
Total CFX System	118	116.020	186.716
Central Florida Expressway Non-system			
Goldenrod Extension ⁽³⁾	2	1.970	3.170

Total Lane Miles

CFX Expressway Facility	Lane Mile Summary	
	Mainline	Ramps
Central Florida Expressway System		
SR 408 (East-West Expressway)	159.433	40.146
SR 528 (Beachline Expressway)	115.481	18.693
SR 417 (Central Florida GreeneWay)	177.277	53.478
SR 429 (Western Beltway and Wekiva Parkway)	141.906	33.265
SR 451 (Western Beltway Connector Road) ⁽²⁾	7.172	0.403
SR 414 (Apopka Expressway)	40.954	17.142
SR 453	7.617	3.420
Total CFX System	649.840	166.547
Central Florida Expressway Non-system		
Goldenrod Extension ⁽³⁾	12.211	2.013

Notes:

1. Measured along the centerline of the expressway facilities.
2. SR 429 (Western Beltway) includes Wekiva Parkway Phase II (Completed March 2018). Shown for informational purposes only.
3. Goldenrod Extension is an Existing CFX Non-system road. Shown for informational purposes only.



Central Florida Expressway Authority (CFX)

Toll Facilities Lane Summary

CFX Expressway Facility	Number of Tolled Lanes
SR 408 (East-West Expressway)	
Hiawassee Mainline Toll Plaza	12
Good Homes Road Ramp Toll Plazas	4
Hiawassee Road Ramp Toll Plazas	4
SUBTOTAL	20
Pine Hills Mainline Toll Plaza	14
Old Winter Garden/Ortman Drive Ramp Toll Plazas	4
John Young Ramp Toll Plazas	4
Orange Blossom Trail Ramp Toll Plazas	4
SUBTOTAL	26
Conway East-West Mainline Toll Plaza	19
Mills Avenue Ramp Toll Plaza	1
Bumby Avenue Ramp Toll Plazas	4
Conway Road Ramp Toll Plazas	4
Andes Avenue - To SR 436 Ramp Toll Plaza	2
SR 436 (Semoran Boulevard) Ramp Toll Plaza	2
Yucatan Drive/SR 436 Ramp Toll Plaza	2
SUBTOTAL	34
Dean Mainline Toll Plaza	12
Dean Road Ramp Toll Plazas	4
Rouse Road Ramp Toll Plazas	4
SUBTOTAL	20
SR 408 SUBTOTAL	100
SR 528 (Beachline Expressway)	
Airport Mainline Toll Plaza ⁽¹⁾	0
Boggy Creek Road/McCoy Road	6
Conway Road/Tradeport Drive	4
SUBTOTAL	16
Beachline Mainline Toll Plaza	12
Innovation Way Ramp Toll Plazas ⁽²⁾	4
SUB-TOTAL	16

1. Airport Mainline Toll Plaza removed in 2016.

2. Airport Mainline Toll Plaza replaced with Innovation Way Ramp Plazas (Opened March 2018).

Central Florida Expressway Authority (CFX)

Toll Facilities Lane Summary - Continued

CFX Expressway Facility	Number of Toll Lanes and Equipment
SR 528 (Beachline Expressway) - <i>continued</i>	
Dallas Mainline Toll Plaza	12
Dallas Boulevard Ramp Toll Plazas	4
SUBTOTAL	16
SR 528 SUBTOTAL	42
SR 417 (Central Florida GreeneWay)	
John Young Mainline Toll Plaza	12
John Young Parkway Ramp Toll Plazas	4
Orange Blossom Trail Ramp Toll Plazas	4
Landstar Boulevard Ramp Toll Plazas	4
SUBTOTAL	24
Boggy Creek Mainline Toll Plaza	14
South Access Road (Ramp Toll Plazas and Gantry)	3
Boggy Creek Road Ramp Toll Plazas	4
Lake Nona Boulevard Ramp Toll Plazas	4
Narcoossee Road Ramp Toll Plazas	4
Moss Park Road Ramp Toll Plazas	4
Dowden Road Ramp Toll Plazas	4
SUBTOTAL	37
Curry Ford Mainline Toll Plazas	14
Lee Vista Boulevard Ramp Toll Plazas	4
Curry Ford Road Ramp Toll Plazas	4
SUBTOTAL	22
University Mainline Toll Plaza	12
SR 50/Colonial Drive Ramp Toll Plazas	4
University Boulevard Ramp Toll Plazas	4
SUBTOTAL	20
SR 417 SUBTOTAL	103

Central Florida Expressway Authority (CFX)

Toll Facilities Lane Summary - Continued

CFX Expressway Facility	Number of Toll Lanes and Equipment
SR 429 (Western Expressway and Wekiva Parkway)	
Forest Lake Mainline Toll Plaza	10
CR 437A (Ocoee-Apopka Road) Ramp Toll Plazas	4
West Road Ramp Toll Plazas	4
Plant Street/Franklin Street/SR 438 Ramp Toll Plazas	4
SUBTOTAL	22
Independence Mainline Toll Plaza	10
CR 535 (Old Winter Garden Road) Ramp Toll Plazas	4
New Independence Parkway Ramp Toll Plazas	4
Schofield Road Ramp Toll Plazas	4
Landstar Boulevard Ramp Toll Plazas	4
SUBTOTAL	22
Ponkan Mainline Gantry ⁽²⁾	4
Mount Plymouth Mainline Gantry ⁽³⁾	4
SUBTOTAL	8
SR 429 SUBTOTAL	52
SR 414 (Apopka Expressway)	
Coral Hills Mainline Toll Plaza	12
Hiawassee Road Ramp Toll Plazas	4
Keene Road Ramp Toll Plazas	4
SUB-TOTAL	20
SR 414 SUBTOTAL	20
SR 453	
Coronado Mainline Gantry ⁽³⁾	4
SYSTEM GRAND TOTAL	321
SR 551 (Goldenrod Extension) ⁽¹⁾	
Goldenrod Mainline Toll Plaza	6

Notes:

1. Goldenrod Extension is an Existing CFX Non-system road. Shown for informational purposes only.
2. Ponkan Mainline Gantry opened to traffic in July of 2017.
3. Coronado and Mount Plymouth opened to traffic in March of 2018.

CFX Expressway	Motorcycle & 2 Axles			3 Axles			4 Axles			5 or More Axles		
	E-PASS	CASH	Pay-By-Plate ⁽⁴⁾	E-PASS	CASH	Pay-By-Plate ⁽⁴⁾	E-PASS	CASH	Pay-By-Plate ⁽⁴⁾	E-PASS	CASH	Pay-By-Plate ⁽⁴⁾
SR 408 (East-West Expressway)												
Hiwassee Mainline Toll Plaza	\$0.86	\$1.00	NA	\$1.71	\$2.00	NA	\$1.99	\$2.25	NA	\$2.57	\$3.00	NA
Good Homes Road	\$0.28	\$0.50	NA	\$0.28	\$0.50	NA	\$0.28	\$0.50	NA	\$0.28	\$0.50	NA
Hiwassee Road	\$0.57	\$0.75	NA	\$0.57	\$0.75	NA	\$0.57	\$0.75	NA	\$0.57	\$0.75	NA
Pine Hills Mainline Toll Plaza	\$1.13	\$1.25	NA	\$1.71	\$2.00	NA	\$1.99	\$2.25	NA	\$2.57	\$3.00	NA
Old Winter Garden Road/Ortman Dr	\$0.86	\$1.00	NA	\$0.86	\$1.00	NA	\$0.86	\$1.00	NA	\$0.86	\$1.00	NA
John Young Parkway	\$0.86	\$1.00	NA	\$0.86	\$1.00	NA	\$0.86	\$1.00	NA	\$0.86	\$1.00	NA
Orange Blossom Trail	\$0.57	\$0.75	NA	\$0.57	\$0.75	NA	\$0.57	\$0.75	NA	\$0.57	\$0.75	NA
Mills Avenue	\$0.57	\$0.75	NA	\$0.57	\$0.75	NA	\$0.57	\$0.75	NA	\$0.57	\$0.75	NA
Conway East-West Mainline Toll Plaza	\$1.13	\$1.25	NA	\$1.71	\$2.00	NA	\$1.99	\$2.25	NA	\$2.57	\$3.00	NA
Bumby Avenue	\$0.57	\$0.75	NA	\$0.57	\$0.75	NA	\$0.57	\$0.75	NA	\$0.57	\$0.75	NA
Conway Road	\$0.86	\$1.00	NA	\$0.86	\$1.00	NA	\$0.86	\$1.00	NA	\$0.86	\$1.00	NA
Andes Ave/SR 436 (Semoran Blvd)	\$1.13	\$1.25	NA	\$1.13	\$1.25	NA	\$1.13	\$1.25	NA	\$1.13	\$1.25	NA
SR 436 (Semoran Blvd)/Yucatan Dr	\$0.86	\$1.00	NA	\$0.86	\$1.00	NA	\$0.86	\$1.00	NA	\$0.86	\$1.00	NA
Dean Mainline Toll Plaza	\$0.86	\$1.00	NA	\$1.71	\$2.00	NA	\$1.99	\$2.25	NA	\$2.57	\$3.00	NA
Dean Road	\$1.57	\$0.75	NA	\$1.57	\$0.75	NA	\$1.57	\$0.75	NA	\$1.57	\$0.75	NA
Rouse Road	\$0.57	\$0.75	NA	\$0.57	\$0.75	NA	\$0.57	\$0.75	NA	\$0.57	\$0.75	NA
SR 528 (Beachline Expressway)												
Boggy Creek Road/McCoy Road	\$1.13	\$1.25	NA	\$1.13	\$1.25	NA	\$1.13	\$1.25	NA	\$1.13	\$1.25	NA
Conway Road/Tradeport Drive	\$1.13	\$1.25	NA	\$1.13	\$1.25	NA	\$1.13	\$1.25	NA	\$1.13	\$1.25	NA
Beachline Mainline Toll Plaza ⁽¹⁾	\$0.91	\$1.25	NA	\$1.79	\$2.00	NA	\$2.09	\$2.50	NA	\$2.66	\$3.00	NA
International Corporate Park Blvd ⁽¹⁾	\$0.61	\$0.75	NA	\$0.61	\$0.75	NA	\$0.61	\$0.75	NA	\$0.61	\$0.75	NA
Dallas Mainline Toll Plaza ⁽²⁾	\$0.52	\$0.75	NA	\$0.79	\$1.00	NA	\$1.04	\$1.25	NA	\$1.04	\$1.25	NA
Dallas Boulevard	\$0.52	\$0.75	NA	\$0.52	\$0.75	NA	\$0.52	\$0.75	NA	\$0.52	\$0.75	NA

Notes:

1. Incremental increase due to the CFX July 2012 toll rate adjustment is applied at the Beachline Main Plaza, Innovation Way ramps and to preserve toll equity along the SR 528.
2. Toll rates shown for the Dallas Mainline Toll Plaza include a \$0.26 EPASS and \$0.75 Cash toll charge regardless of the number of axles that is allocated to the FDOT.
3. Added Ponkan Toll Gantry for the opening of SR 429 Wekiva Parkway Section A (July 2017).
4. FDOT toll rate increase of \$0.25 for cash payment at Dallas Mainline Toll Plaza October 2017.
5. Added Mount Plymouth and Coronado Toll Gantries for the opening of SR 429 Wekiva Parkway Section B and SR 453 (March 2018).
6. Pay by Plate invoices for the tolling points noted with a NA include the cash rate plus \$0.20 fee.
7. Toll Rate increase effective July 1, 2018 (Excludes Good Homes Road, Landstar Boulevard, Ponkan Toll Gantry, Mount Plymouth Toll Gantry, and Coronado Toll Gantry.)



Toll Rate Schedule

CFX Expressway	Motorcycle & 2 Axles			3 Axles			4 Axles			5 or More Axles		
	E-PASS	CASH	Pay-By-Plate(4)	E-PASS	CASH	Pay-By-Plate(4)	E-PASS	CASH	Pay-By-Plate(4)	E-PASS	CASH	Pay-By-Plate(4)
	SR 417 (Central Florida GreeneWay)											
John Young Mainline Toll Plaza	\$1.43	\$1.75	NA	\$1.99	\$2.25	NA	\$2.57	\$3.00	NA	\$3.13	\$3.50	NA
John Young Parkway	\$0.86	\$1.00	NA	\$0.86	\$1.00	NA	\$0.86	\$1.00	NA	\$0.86	\$1.00	NA
Orange Blossom Trail	\$0.57	\$0.75	NA	\$0.57	\$0.75	NA	\$0.57	\$0.75	NA	\$0.57	\$0.75	NA
Landstar Boulevard	\$0.50	\$0.50	NA	\$0.50	\$0.50	NA	\$0.50	\$0.50	NA	\$0.50	\$0.50	NA
Boggy Creek Mainline Toll Plaza	\$1.43	\$1.75	NA	\$1.99	\$2.25	NA	\$2.57	\$3.00	NA	\$3.13	\$3.50	NA
South Access Rd/Int'l Airport	\$1.13	\$1.25	NA	\$1.13	\$1.25	NA	\$1.13	\$1.25	NA	\$1.13	\$1.25	NA
Boggy Creek Road	\$1.13	\$1.25	NA	\$1.13	\$1.25	NA	\$1.13	\$1.25	NA	\$1.13	\$1.25	NA
Lake Nona Boulevard	\$0.86	\$1.00	NA	\$0.86	\$1.00	NA	\$0.86	\$1.00	NA	\$0.86	\$1.00	NA
Narcoossee Road	\$0.86	\$1.00	NA	\$0.86	\$1.00	NA	\$0.86	\$1.00	NA	\$0.86	\$1.00	NA
Moss Park Road	\$0.57	\$0.75	NA	\$0.57	\$0.75	NA	\$0.57	\$0.75	NA	\$0.57	\$0.75	NA
Dowden Road	\$0.57	\$0.75	NA	\$0.57	\$0.75	NA	\$0.57	\$0.75	NA	\$0.57	\$0.75	NA
Curry Ford Mainline Toll Plaza	\$0.86	\$1.00	NA	\$1.71	\$2.00	NA	\$1.99	\$2.25	NA	\$2.57	\$3.00	NA
Lee Vista Boulevard	\$0.57	\$0.75	NA	\$0.57	\$0.75	NA	\$0.57	\$0.75	NA	\$0.57	\$0.75	NA
Curry Ford Road	\$0.57	\$0.75	NA	\$0.57	\$0.75	NA	\$0.57	\$0.75	NA	\$0.57	\$0.75	NA
University Mainline Toll Plaza	\$0.86	\$1.00	NA	\$1.71	\$2.00	NA	\$1.99	\$2.25	NA	\$2.57	\$3.00	NA
SR 50 (Colonial Drive)	\$0.57	\$0.75	NA	\$0.57	\$0.75	NA	\$0.57	\$0.75	NA	\$0.57	\$0.75	NA
University Boulevard	\$0.57	\$0.75	NA	\$0.57	\$0.75	NA	\$0.57	\$0.75	NA	\$0.57	\$0.75	NA
SR 429 (Western Beltway and Wekiva Parkway)												
Forest Lake Mainline Toll Plaza	\$1.43	\$1.75	NA	\$1.99	\$2.25	NA	\$2.57	\$3.00	NA	\$3.13	\$3.50	NA
CR 437A (Ocoee-Apopka Road)	\$0.57	\$0.75	NA	\$0.57	\$0.75	NA	\$0.57	\$0.75	NA	\$0.57	\$0.75	NA
West Road	\$0.86	\$1.00	NA	\$0.86	\$1.00	NA	\$0.86	\$1.00	NA	\$0.86	\$1.00	NA
Plant Street/Franklin Street/SR 438	\$0.57	\$0.75	NA	\$0.57	\$0.75	NA	\$0.57	\$0.75	NA	\$0.57	\$0.75	NA

Notes:

1. Incremental increase due to the CFX July 2012 toll rate adjustment is applied at the Beachline Main Plaza and ICF Blvd ramps to preserve toll equity along the SR 528.
2. Toll rates shown for the Dallas Mainline Toll Plaza include a \$0.26 EPASS and \$0.50 Cash toll charge regardless of the number of axles that is allocated to the FDOT.
3. Airport Mainline Toll is collected at Turnpike Beachline West Mainline Toll Plaza
4. FDOT toll increase of \$0.25 for cash payment at Dallas Mainline Toll Plaza October 2017
5. Added Mount Plymouth and Coronado Toll Gantries for the opening of SR 429 Wekiva Parkway Section B and SR 453 (March 2018)
6. Pay by Plate invoices for tolling points noted with a NA include the cash rate plus \$0.20 fee
7. Toll Rate increase effective July 1, 2018 (Excludes Good Homes Road, Landstar Boulevard, Ponkan Toll Gantry, Mount Plymouth Toll Gantry, and Coronado Toll Gantry.)



Toll Rate Schedule

CFX Expressway	Motorcycle & 2 Axles			3 Axles			4 Axles			5 or More Axles		
	E-PASS	CASH	Pay-By-Plate(4)	E-PASS	CASH	Pay-By-Plate(4)	E-PASS	CASH	Pay-By-Plate(4)	E-PASS	CASH	Pay-By-Plate(4)
	SR 429 (Western Beltway and Wekiva Parkway) - Continued											
Independence Mainline Toll Plaza	\$1.43	\$1.75	NA	\$1.99	\$2.25	NA	\$2.57	\$3.00	NA	\$3.13	\$3.50	NA
CR 535	\$0.57	\$0.75	NA	\$0.57	\$0.75	NA	\$0.57	\$0.75	NA	\$0.57	\$0.75	NA
New Independence Parkway	\$0.86	\$1.00	NA	\$0.86	\$1.00	NA	\$0.86	\$1.00	NA	\$0.86	\$1.00	NA
Schofield Road	\$0.30	\$0.50	NA	\$0.30	\$0.50	NA	\$0.30	\$0.50	NA	\$0.30	\$0.50	NA
Ponkan Mainline Toll Plaza	\$0.82	NA	\$1.41	\$1.23	NA	\$1.82	\$1.64	NA	\$2.23	\$2.04	NA	\$2.63
Mount Plymouth Mainline Toll Plaza	\$0.77	NA	\$1.36	\$1.16	NA	\$1.75	\$1.53	NA	\$2.12	\$1.92	NA	\$2.51
SR 453												
Coronado Mainline Gantry	\$0.66	NA	\$1.25	\$1.00	NA	\$1.59	\$1.33	NA	\$1.92	\$1.67	NA	\$2.26
SR 414 (Apopka Expressway)												
Coral Hills Mainline Toll Plaza	\$1.13	\$1.25	NA	\$1.71	\$2.00	NA	\$2.27	\$2.50	NA	\$2.85	\$3.25	NA
Keene Road	\$0.57	\$0.75	NA	\$0.57	\$0.75	NA	\$0.57	\$0.75	NA	\$0.57	\$0.75	NA
Hiwassee Road	\$0.30	\$0.50	NA	\$0.30	\$0.50	NA	\$0.30	\$0.50	NA	\$0.30	\$0.50	NA
Goldenrod Road Extension - Non System												
Goldenrod Mainline Toll Plaza	\$0.50	\$0.50	\$0.70	\$0.50	\$0.50	\$0.70	\$0.50	\$0.50	\$0.70	\$0.50	\$0.50	\$0.70

Notes:

1. Incremental increase due to the CFX July 2012 toll rate adjustment is applied at the Beachline Main Plaza and ICF Blvd ramps to preserve toll equity along the SR 528.
2. Toll rates shown for the Dallas Mainline Toll Plaza include a \$0.26 EPASS and \$0.50 Cash toll charge regardless of the number of axles that is allocated to the FDOT.
3. Airport Mainline Toll is collected at Turnpike Beachline West Mainline Toll Plaza
4. FDOT toll increase of \$0.25 for cash payment at Dallas Mainline Toll Plaza October 2017
5. Added Mount Plymouth and Coronado Toll Gantries for the opening of SR 429 Wekiva Parkway Section B and SR 453 (March 2018)
6. Pay by Plate invoices for tolling points noted with a NA include the cash rate plus \$0.20 fee
7. Toll Rate increase effective July 1, 2018 (Excludes Good Homes Road, Landstar Boulevard, Ponkan Toll Gantry, Mount Plymouth Toll Gantry, and Coronado Toll Gantry.)



Toll Rate Schedule

Distance Between Interchanges



2018 Traffic Data and Statistics Manual
CENTRAL FLORIDA EXPRESSWAY AUTHORITY

Distance From	Distance To				
	Florida's Turnpike	SR 50/Clarke Road	Good Homes Road	Hiwassee Road	Kirkman Road
	Distance (miles)	Distance (miles)	Distance (miles)	Distance (miles)	Distance (miles)
Florida's Turnpike	-----	-----	1.556	3.336	4.493
SR 50/Clarke Road	-----	-----	0.705	2.485	3.642
Good Homes Road	1.556	0.705	-----	1.780	2.937
Hiwassee Road	3.336	2.485	1.780	-----	1.157
Kirkman Road	4.493	3.642	2.937	1.157	-----
Pine Hills Road	-----	-----	-----	-----	-----
Old Winter Garden/Mercy-Ortman Drive	-----	-----	-----	-----	-----
John Young Parkway	7.252	6.401	5.696	3.916	2.759
Tampa Avenue	7.916	7.065	6.360	4.580	3.423
Orange Blossom Trail	8.430	7.579	6.874	5.094	3.937
Interstate 4 (I-4)	9.000	8.149	7.444	5.664	4.507
Orange Avenue	9.592	8.741	8.036	6.256	5.099
Rosalind Avenue	-----	-----	-----	-----	-----
Mills Avenue	-----	-----	-----	-----	-----
Bumby Avenue	11.216	10.365	9.660	7.880	6.723
Crystal Lake Drive	-----	-----	-----	-----	-----
Conway Road	12.466	11.615	10.910	9.130	7.973
Andes Avenue	13.208	12.357	11.652	9.872	8.715
Semorán Boulevard (SR 436)	13.738	12.887	12.182	10.402	9.245
Yucatan Drive	-----	-----	-----	-----	-----
Goldenrod Road	15.257	14.406	13.701	11.921	10.764
Chickasaw Trail	15.826	14.975	14.270	12.490	11.333
SR 417 (GreeneWay)	17.215	16.364	15.659	13.879	12.722
Dean Road	18.042	17.191	16.486	14.706	13.549
Rouse Road	19.314	18.463	17.758	15.978	14.821
Alafaya Trail	20.518	19.667	18.962	17.182	16.025
SR 50 (East Colonial Drive)	22.209	21.358	20.653	18.873	17.716



SR 408 (East-West Expressway) Distance Between Interchanges (Miles)

Distance From	Distance To				
	Pine Hills Road	OWG/Mercy/Ortman	John Young Parkway	Tampa Avenue	Orange Blossom Trail
	Distance (miles)	Distance (miles)	Distance (miles)	Distance (miles)	Distance (miles)
Florida's Turnpike	-----	-----	7.252	7.916	8.430
SR 50/Clarke Road	-----	-----	6.401	7.065	7.579
Good Homes Road	-----	-----	5.696	6.360	6.874
Hiwassee Road	-----	-----	3.916	4.580	5.094
Kirkman Road	-----	-----	2.759	3.423	3.937
Pine Hills Road	-----	-----	2.169	2.833	3.346
Old Winter Garden/Mercy-Ortman Drive	-----	-----	1.078	1.742	2.256
John Young Parkway	2.169	1.078	-----	0.664	1.178
Tampa Avenue	2.833	1.742	0.664	-----	-----
Orange Blossom Trail	3.346	2.256	1.178	-----	-----
Interstate 4 (I-4)	3.916	2.826	1.748	-----	0.570
Orange Avenue	4.509	3.418	2.340	-----	1.163
Rosalind Avenue	-----	-----	-----	-----	-----
Mills Avenue	-----	-----	-----	-----	-----
Bumby Avenue	6.133	5.042	3.964	-----	2.787
Crystal Lake Drive	-----	-----	-----	-----	-----
Conway Road	7.383	6.292	5.214	-----	4.037
Andes Avenue	8.125	7.034	5.956	-----	4.779
Semorran Boulevard (SR 436)	8.655	7.564	6.486	-----	5.309
Yucatan Drive	-----	-----	-----	-----	-----
Goldenrod Road	10.174	9.083	8.005	-----	6.828
Chickasaw Trail	10.743	9.652	8.574	-----	7.397
SR 417 (GreeneWay)	12.132	11.041	9.963	-----	8.786
Dean Road	12.959	11.868	10.790	-----	9.613
Rouse Road	14.231	13.140	12.062	-----	10.885
Alafaya Trail	15.435	14.344	13.266	-----	12.089
SR 50 (East Colonial Drive)	17.126	16.035	14.957	-----	13.780



SR 408 (East-West Expressway) Distance Between Interchanges (Miles) - Continued

Distance From	Distance To				
	Interstate 4 (I-4)	Orange Avenue	Rosalind Avenue	Mills Avenue	Bumby Avenue
	Distance (miles)	Distance (miles)	Distance (miles)	Distance (miles)	Distance (miles)
Florida's Turnpike	9.000	9.592	-----	10.455	11.216
SR 50/Clarke Road	8.149	8.741	-----	9.604	10.365
Good Homes Road	7.444	8.036	-----	8.899	9.660
Hiwassee Road	5.664	6.256	-----	7.119	7.880
Kirkman Road	4.507	5.099	-----	5.962	6.723
Pine Hills Road	3.916	4.509	-----	5.372	6.133
Old Winter Garden/Mercy-Ortman Drive	2.826	3.418	-----	4.281	5.042
John Young Parkway	1.748	2.340	-----	3.203	3.964
Tampa Avenue	-----	-----	-----	-----	-----
Orange Blossom Trail	0.570	1.163	-----	2.026	2.787
Interstate 4 (I-4)	-----	0.592	-----	1.456	2.217
Orange Avenue	-----	-----	-----	-----	-----
Rosalind Avenue	-----	-----	-----	0.583	1.344
Mills Avenue	-----	-----	-----	-----	0.761
Bumby Avenue	2.217	-----	1.344	0.761	-----
Crystal Lake Drive	-----	-----	-----	-----	-----
Conway Road	3.467	-----	2.594	2.011	-----
Andes Avenue	4.209	-----	3.336	2.753	-----
Semorán Boulevard (SR 436)	4.739	-----	3.866	3.283	-----
Yucatan Drive	-----	-----	-----	-----	-----
Goldenrod Road	6.258	-----	5.385	4.802	-----
Chickasaw Trail	6.827	-----	5.954	5.371	-----
SR 417 (GreeneWay)	8.216	-----	7.343	6.760	-----
Dean Road	9.043	-----	8.170	7.587	-----
Rouse Road	10.315	-----	9.442	8.859	-----
Alafaya Trail	11.519	-----	10.646	10.063	-----
SR 50 (East Colonial Drive)	13.210	-----	12.337	11.754	-----



SR 408 (East-West Expressway) Distance Between Interchanges (Miles) - Continued

Distance From	Distance To							
	Crystal Lake Drive	Conway Road	Andes Avenue	Semoran Blvd.	Yucatan Drive	Goldenrod Road		
	Distance (miles)	Distance (miles)	Distance (miles)	Distance (miles)	Distance (miles)	Distance (miles)		
Florida's Turnpike	-----	12.466	13.208	-----	-----	15.257		
SR 50/Clarke Road	-----	11.615	12.357	-----	-----	14.406		
Good Homes Road	-----	10.910	11.652	-----	-----	13.701		
Hiwassee Road	-----	9.130	9.872	-----	-----	11.921		
Kirkman Road	-----	7.973	8.715	-----	-----	10.764		
Pine Hills Road	-----	7.383	8.125	-----	-----	10.174		
Old Winter Garden/Mercy-Ortman Drive	-----	6.292	7.034	-----	-----	9.083		
John Young Parkway	-----	5.214	5.956	-----	-----	8.005		
Tampa Avenue	-----	-----	-----	-----	-----	-----		
Orange Blossom Trail	-----	4.037	4.779	-----	-----	6.828		
Interstate 4 (I-4)	-----	3.467	4.209	-----	-----	6.258		
Orange Avenue	-----	2.874	3.616	-----	-----	5.665		
Rosalind Avenue	-----	2.594	3.336	-----	-----	5.385		
Mills Avenue	-----	2.011	2.753	-----	-----	4.802		
Bumby Avenue	-----	-----	-----	-----	-----	-----		
Crystal Lake Drive	-----	0.630	1.372	-----	-----	3.421		
Conway Road	0.630	-----	-----	-----	-----	-----		
Andes Avenue	1.372	-----	-----	-----	-----	-----		
Semoran Boulevard (SR 436)	1.902	-----	-----	-----	-----	-----		
Yucatan Drive	-----	-----	-----	-----	-----	1.240		
Goldenrod Road	3.421	-----	-----	1.519	-----	-----		
Chickasaw Trail	3.990	-----	-----	2.088	-----	-----		
SR 417 (GreeneWay)	5.379	-----	-----	3.477	-----	1.958		
Dean Road	6.206	-----	-----	4.304	-----	2.785		
Rouse Road	7.478	-----	-----	5.576	-----	4.057		
Alafaya Trail	8.682	-----	-----	6.780	-----	5.261		
SR 50 (East Colonial Drive)	10.373	-----	-----	8.471	-----	6.952		



SR 408 (East-West Expressway) Distance Between Interchanges (Miles) - Continued

Distance From	Distance To							
	Chickasaw Trail	SR 417 (GreeneWay)	Dean Road	Rouse Road	Alafaya Trail	SR 50 (Colonial Dr.)		
	Distance (miles)	Distance (miles)	Distance (miles)	Distance (miles)	Distance (miles)	Distance (miles)	Distance (miles)	Distance (miles)
Florida's Turnpike	15.826	17.215	18.042	19.314	20.518	22.209		
SR 50/Clarke Road	14.975	16.364	17.191	18.463	19.667	21.358		
Good Homes Road	14.270	15.659	16.486	17.758	18.962	20.653		
Hiwassee Road	12.490	13.879	14.706	15.978	17.182	18.873		
Kirkman Road	11.333	12.722	13.549	14.821	16.025	17.716		
Pine Hills Road	10.743	12.132	12.959	14.231	15.435	17.126		
Old Winter Garden/Mercy-Ortman Drive	9.652	11.041	11.868	13.140	14.344	16.035		
John Young Parkway	8.574	9.963	10.790	12.062	13.266	14.957		
Tampa Avenue	-----	-----	-----	-----	-----	-----		
Orange Blossom Trail	7.397	8.786	9.613	10.885	12.089	13.780		
Interstate 4 (I-4)	6.827	8.216	9.043	10.315	11.519	13.210		
Orange Avenue	-----	-----	-----	-----	-----	-----		
Rosalind Avenue	5.954	7.343	8.170	9.442	10.646	12.337		
Mills Avenue	5.371	6.760	7.587	8.859	10.063	11.754		
Bumby Avenue	-----	-----	-----	-----	-----	-----		
Crystal Lake Drive	3.990	5.379	6.206	7.478	8.682	10.373		
Conway Road	-----	-----	-----	-----	-----	-----		
Andes Avenue	-----	-----	-----	-----	-----	-----		
Semorán Boulevard (SR 436)	-----	-----	-----	-----	-----	-----		
Yucatan Drive	1.809	3.198	4.025	5.297	6.501	8.192		
Goldenrod Road	-----	1.958	2.785	4.057	5.261	6.952		
Chickasaw Trail	-----	-----	-----	-----	-----	-----		
SR 417 (GreeneWay)	-----	-----	0.827	2.099	3.303	4.994		
Dean Road	-----	0.827	-----	1.272	2.476	4.167		
Rouse Road	-----	2.099	1.272	-----	1.204	2.895		
Alafaya Trail	-----	3.303	2.476	1.204	-----	-----		
SR 50 (East Colonial Drive)	-----	4.994	4.167	2.895	-----	-----		



SR 408 (East-West Expressway) Distance Between Interchanges (Miles) - Continued

Distance From	Distance To				
	Boggy Creek Road	Tradeport/Conway	Semorán Blvd/Airport	Goldenrod Road	Narcoossee Road
	Distance (miles)	Distance (miles)	Distance (miles)	Distance (miles)	Distance (miles)
US 441/Florida's Turnpike	3.580	4.657	6.157	7.520	8.875
Boggy Creek Road	-----	1.077	2.577	3.940	5.295
Tradeport Drive/Conway Road	1.077	-----	1.501	2.863	4.218
Semorán Boulevard/Airport	2.577	1.501	-----	1.363	2.718
Goldenrod Road	3.940	2.863	1.363	-----	1.355
Narcoossee Road	5.295	4.218	2.718	1.355	-----
SR 417 (GreeneWay)	7.385	6.308	4.807	3.445	2.090
Innovation Way ⁽¹⁾	11.603	10.526	9.026	7.663	6.308
Dallas Boulevard	15.617	14.540	13.040	11.677	10.322
SR 520	22.667	21.591	20.090	18.728	17.373
Brevard County Line	27.605	26.529	25.028	23.666	22.311

Distance From	Distance To				
	SR 417 (GreeneWay)	Monument Pkwy/ICP ⁽¹⁾	Dallas Boulevard	SR 520	Brevard County Line
	Distance (miles)	Distance (miles)	Distance (miles)	Distance (miles)	Distance (miles)
US 441/Florida's Turnpike	10.965	15.183	19.197	26.247	31.185
Boggy Creek Road	7.385	11.603	15.617	22.667	27.605
Tradeport Drive/Conway Road	6.308	10.526	14.540	21.591	26.529
Semorán Boulevard/Airport	4.807	9.026	13.040	20.090	25.028
Goldenrod Road	3.445	7.663	11.677	18.728	23.666
Narcoossee Road	2.090	6.308	10.322	17.373	22.311
SR 417 (GreeneWay)	-----	4.218	8.232	15.283	20.221
Innovation Way ⁽¹⁾	4.218	-----	4.014	11.065	16.003
Dallas Boulevard	8.232	4.014	-----	-----	-----
SR 520	15.283	11.065	-----	-----	4.938
Brevard County Line	20.221	16.003	-----	4.938	-----

Note:

1. ICP Boulevard exit Removed and Replaced with Innovation Way exit (Opened March 2018).



SR 528 (Beachline Expressway) Distance Between Interchanges (Miles)

SECTION V

321

Distance From	Distance To				
	International Drive	John Young Parkway	Orange Blossom Trail	Florida's Turnpike	Landstar Boulevard
	Distance (miles)	Distance (miles)	Distance (miles)	Distance (miles)	Distance (miles)
International Drive	-----	4.240	5.604	-----	7.948
John Young Parkway	4.240	-----	1.364	-----	3.707
Orange Blossom Trail	5.604	1.364	-----	0.967	2.344
Florida's Turnpike	-----	-----	-----	-----	1.376
Landstar Boulevard	7.948	3.707	2.344	1.376	-----
South Access Road (Int'l Airport)	11.475	7.234	5.871	4.903	3.527
Boggy Creek Road	11.475	7.234	5.871	4.903	3.527
Lake Nona Boulevard	13.566	9.326	7.962	6.995	5.619
Narcoossee Road	16.117	11.877	10.513	9.546	8.170
Moss Park Road	17.579	13.339	11.975	11.007	9.631
Dowden Road	18.503	14.262	12.899	11.931	10.555
SR 528 (Beachline Expressway)	20.131	15.891	14.527	13.560	12.184
Lee Vista Boulevard	22.033	17.793	16.429	15.462	14.086
Curry Ford Road	24.336	20.096	18.732	17.765	16.389
SR 408 (East-West Expressway)	27.064	22.824	21.460	20.492	19.116
SR 50 (Colonial Drive)	28.756	24.516	23.152	22.184	20.808
University Boulevard	31.024	26.784	25.420	24.452	23.076
Aloma Avenue	32.657	28.417	27.053	26.086	24.710



SR 417 (Central Florida GreeneWay) Distance Between Interchanges (Miles)

Distance From	Distance To				
	South Access (Airport)	Boggy Creek Road	Lake Nona Boulevard	Narcoossee Road	Moss Park Road
	Distance (miles)	Distance (miles)	Distance (miles)	Distance (miles)	Distance (miles)
International Drive	10.829	11.475	13.566	16.117	17.579
John Young Parkway	7.234	7.234	9.326	11.877	13.339
Orange Blossom Trail	5.871	5.871	7.962	10.513	11.975
Florida's Turnpike	4.903	4.903	6.995	9.546	11.007
Landstar Boulevard	3.527	3.527	5.619	8.170	9.631
South Access Road (Int'l Airport)	-----	-----	2.092	4.643	6.104
Boggy Creek Road	-----	-----	2.092	4.643	6.104
Lake Nona Boulevard	2.092	2.092	-----	2.551	4.013
Narcoossee Road	4.643	4.643	2.551	-----	1.462
Moss Park Road	6.104	6.104	4.013	1.462	-----
Dowden Road	7.028	7.028	4.937	2.385	0.924
SR 528 (Beachline Expressway)	8.657	8.657	6.565	4.014	2.553
Lee Vista Boulevard	10.559	10.559	8.467	5.916	4.455
Curry Ford Road	12.862	12.862	10.770	8.219	6.758
SR 408 (East-West Expressway)	15.589	15.589	13.498	10.947	9.485
SR 50 (Colonial Drive)	17.281	17.281	15.190	12.639	11.177
University Boulevard	19.549	19.549	17.458	14.907	13.445
Aloma Avenue	21.183	21.183	19.091	16.540	15.078



SR 417 (Central Florida GreeneWay) Distance Between Interchanges (Miles) - Continued

Distance From	Distance To			
	Dowden Road	SR 528 (Beachline)	Lee Vista Boulevard	Curry Ford Road
	Distance (miles)	Distance (miles)	Distance (miles)	Distance (miles)
International Drive	18.503	20.131	22.033	24.336
John Young Parkway	14.262	15.891	17.793	20.096
Orange Blossom Trail	12.899	14.527	16.429	18.732
Florida's Turnpike	11.931	13.560	15.462	17.765
Landstar Boulevard	10.555	12.184	14.086	16.389
South Access Road (Int'l Airport)	7.028	8.657	10.559	12.862
Boggy Creek Road	7.028	8.657	10.559	12.862
Lake Nona Boulevard	4.937	6.565	8.467	10.770
Narcoossee Road	2.385	4.014	5.916	8.219
Moss Park Road	0.924	2.553	4.455	6.758
Dowden Road	-----	1.629	3.531	5.834
SR 528 (Beachline Expressway)	1.629	-----	1.902	4.205
Lee Vista Boulevard	3.531	1.902	-----	2.303
Curry Ford Road	5.834	4.205	2.303	-----
SR 408 (East-West Expressway)	8.561	6.933	5.031	2.728
SR 50 (Colonial Drive)	10.253	8.625	6.723	4.420
University Boulevard	12.521	10.893	8.991	6.688
Aloma Avenue	14.155	12.526	10.624	8.321



SR 417 (Central Florida GreeneWay) Distance Between Interchanges (Miles) - Continued

Distance From	Distance To			
	SR 408 (East West)	SR 50 (Colonial Dr.)	University Boulevard	Aloma Avenue
	Distance (miles)	Distance (miles)	Distance (miles)	Distance (miles)
International Drive	27.064	28.756	31.024	32.657
John Young Parkway	22.824	24.516	26.784	28.417
Orange Blossom Trail	21.460	23.152	25.420	27.053
Florida's Turnpike	20.492	22.184	24.452	26.086
Landstar Boulevard	19.116	20.808	23.076	24.710
South Access Rd (Int'l Airport)	15.589	17.281	19.549	21.183
Boggy Creek Road	15.589	17.281	19.549	21.183
Lake Nona Boulevard	13.498	15.190	17.458	19.091
Narcoossee Road	10.947	12.639	14.907	16.540
Moss Park Road	9.485	11.177	13.445	15.078
Dowden Road	8.561	10.253	12.521	14.155
SR 528 (Beachline Expressway)	6.933	8.625	10.893	12.526
Lee Vista Boulevard	5.031	6.723	8.991	10.624
Curry Ford Road	2.728	4.420	6.688	8.321
SR 408 (East-West Expressway)	-----	1.692	3.960	5.593
SR 50 (Colonial Drive)	1.692	-----	2.268	3.901
University Boulevard	3.960	2.268	-----	1.633
Aloma Avenue	5.593	3.901	1.633	-----



SR 417 (Central Florida GreeneWay) Distance Between Interchanges (Miles) - Continued

Distance From	Distance To				
	Seidel Road	Schofield Road	New Independence	CR 535	Florida's Turnpike
	Distance (miles)	Distance (miles)	Distance (miles)	Distance (miles)	Distance (miles)
Seidel Road	-----	2.120	2.120	8.449	11.405
Schofield Road	2.120	-----	-----	6.329	9.285
New Independence Parkway	4.079	1.959	1.959	4.370	7.326
CR 535 (Old Winter Garden)	8.449	6.329	6.329	-----	2.956
Florida's Turnpike (SR 91)	11.405	9.285	9.285	2.956	-----
SR 50 (West Colonial Drive)	11.734	9.615	9.615	3.286	-----
Plant Street/Franklin Street/SR 438	13.171	11.052	11.052	4.723	1.767
West Road	15.683	13.563	13.563	7.234	4.278
CR 437A (Ocoee Apopka Road)	18.197	16.077	16.077	9.748	6.792
SR 414 (Apopka Expressway)	19.556	17.436	17.436	11.107	8.151
SR 429 Connector Road	22.980	20.861	20.861	14.532	11.576
Kelly Park Road	27.044	24.925	22.966	18.596	15.640
SR 453	28.376	26.257	24.298	19.928	16.972
SR 46	30.848	28.729	26.770	22.400	19.444



SR 429 (Western Beltway) Distance Between Interchanges (Miles)

Distance From	Distance To					
	SR 50 (Colonial Dr.)	Plant/Franklin St.	West Road	CR 437A	SR 414 (Apopka Expwy)	
	Distance (miles)	Distance (miles)	Distance (miles)	Distance (miles)	Distance (miles)	
Seidel Road	11.734	13.171	15.683	18.197	19.556	
Schofield Road	9.615	11.052	13.563	16.077	17.436	
New Independence Parkway	7.656	9.093	11.604	14.118	15.477	
CR 535 (Old Winter Garden)	3.286	4.723	7.234	9.748	11.107	
Florida's Turnpike (SR 91)	-----	1.767	4.278	6.792	8.151	
SR 50 (West Colonial Drive)	-----	1.437	3.949	6.463	7.822	
Plant Street/Franklin Street/SR 438	1.437	-----	2.512	5.026	6.385	
West Road	3.949	2.512	-----	2.514	3.873	
CR 437A (Ocoee Apopka Road)	6.463	5.026	2.514	-----	1.359	
SR 414 (Apopka Expressway)	7.822	6.385	3.873	1.359	-----	
SR 429 Connector Road	11.246	9.809	7.298	4.784	3.424	
Kelly Park Road	15.310	13.873	11.362	8.902	7.542	
SR 453	16.642	15.205	12.694	10.234	8.874	
SR 46	19.114	17.677	15.166	12.652	11.292	



SR 429 (Western Beltway) Distance Between Interchanges (Miles)

Distance From	Distance To			
	SR 429 Connector Rd.	Kelly Park Road	SR 453	SR 46
	Distance (miles)	Distance (miles)	Distance (miles)	Distance (miles)
Seidel Road	22.980	27.098	28.430	30.848
Schofield Road	20.861	24.979	26.311	28.729
New Independence Parkway	18.902	23.020	24.352	26.770
CR 535 (Old Winter Garden)	14.532	18.650	19.982	22.400
Florida's Turnpike (SR 91)	11.576	15.694	17.026	19.444
SR 50 (West Colonial Drive)	11.246	15.364	16.696	19.114
Plant Street/Franklin Street/SR 438	9.809	13.927	15.259	17.677
West Road	7.298	11.416	12.748	15.166
CR 437A (Ocoee Apopka Road)	4.784	8.902	10.234	12.652
SR 414 (Apopka Expressway)	3.424	7.542	8.874	11.292
SR 429 Connector Road	-----	4.118	5.450	7.868
Kelly Park Road	4.118	-----	1.332	3.750
SR 453	5.450	1.332	-----	2.418
SR 46	7.868	3.750	2.418	-----



SR 429 (Wekiva Parkway) Distance Between Interchanges (Miles)

Distance From	Distance To			
	SR 429 Connector Rd.	SR 451	Marden Road	Keene Road
	Distance (miles)	Distance (miles)	Distance (miles)	Distance (miles)
SR 429 Connector Road	-----	4.221	4.519	6.636
SR 429/451 (Western Beltway)	4.221	-----	0.298	2.415
Marden Road	4.519	0.298	-----	2.117
Keene Road	6.636	2.415	2.117	-----
Hiwassee Road (CR 435)	7.926	3.705	3.407	1.290
OBT - US 441 (East)	9.378	5.157	4.859	2.743
Bear Lake Road/Rose Avenue	10.070	5.849	5.551	3.435

Distance From	Distance To		
	Hiwassee Road	OBT - US 441 (East)	Bear Lake/Rose Ave.
	Distance (miles)	Distance (miles)	Distance (miles)
SR 429 Connector Road	7.926	9.378	10.070
SR 429/451 (Western Beltway)	3.705	5.157	5.849
Marden Road	3.407	4.859	5.551
Keene Road	1.290	2.743	3.435
Hiwassee Road (CR 435)	-----	1.453	2.145
OBT - US 441 (East)	1.453	-----	0.692
Bear Lake Road/Rose Avenue	2.145	0.692	-----



SR 414 (Apopka Expressway) Distance Between Interchanges (Miles)

Distance From	Distance To	
	US 441/Vick Rd Ext.	SR 429/414 System Int
	Distance (miles)	Distance (miles)
US 441/Vick Road Extension	1.670	1.670
SR 429/414 System Interchange	1.670	1.670



SR 451 (Western Beltway Connector) Distance Between Interchanges (Miles)

Distance From	Distance To	
	SR 429/453 System Int	SR 46
	Distance (miles)	Distance (miles)
SR 429/453 System Interchange SR 46	1.983	1.983



SR 453 Distance Between Interchanges (Miles)

Toll Rates Between Interchanges



2018 Traffic Data and Statistics Manual
CENTRAL FLORIDA EXPRESSWAY AUTHORITY

From	To									
	Florida's Turnpike		SR 50/ Clarke Road		Good Homes Road		Hiwassee Road		Kirkman Road	
	E-PASS	CASH	E-PASS	CASH	E-PASS	CASH	E-PASS	CASH	E-PASS	CASH
Florida's Turnpike	-----	-----	-----	-----	\$0.28	\$0.50	\$0.86	\$1.00	\$0.86	\$1.00
SR 50/Clarke Road	-----	-----	-----	-----	\$0.28	\$0.50	\$0.86	\$1.00	\$0.86	\$1.00
Good Homes Road	\$0.28	\$0.50	\$0.28	\$0.50	-----	-----	-----	-----	\$0.86	\$1.00
Hiwassee Road	\$0.57	\$0.75	\$0.57	\$0.75	\$0.57	\$0.75	-----	-----	\$0.86	\$1.00
Kirkman Road	\$0.86	\$1.00	\$0.86	\$1.00	\$0.86	\$1.00	\$0.57	\$0.75	-----	-----
Pine Hills Road	-----	-----	-----	-----	-----	-----	-----	-----	-----	-----
Old Winter Garden/Mercy-Ortman Drive	-----	-----	-----	-----	-----	-----	-----	-----	-----	-----
John Young Parkway	\$1.99	\$2.25	\$1.99	\$2.25	\$1.99	\$2.25	\$1.70	\$2.00	\$1.13	\$1.25
Tampa Avenue	\$1.99	\$2.25	\$1.99	\$2.25	\$1.99	\$2.25	\$1.70	\$2.00	\$1.13	\$1.25
Orange Blossom Trail	\$1.99	\$2.25	\$1.99	\$2.25	\$1.99	\$2.25	\$1.70	\$2.00	\$1.13	\$1.25
Interstate 4 (I-4)	\$1.99	\$2.25	\$1.99	\$2.25	\$1.99	\$2.25	\$1.70	\$2.00	\$1.13	\$1.25
Orange Avenue	\$1.99	\$2.25	\$1.99	\$2.25	\$1.99	\$2.25	\$1.70	\$2.00	\$1.13	\$1.25
Rosalind Avenue	-----	-----	-----	-----	-----	-----	-----	-----	-----	-----
Mills Avenue	-----	-----	-----	-----	-----	-----	-----	-----	-----	-----
Bumby Avenue	\$2.56	\$3.00	\$2.56	\$3.00	\$2.56	\$3.00	\$2.27	\$2.75	\$1.70	\$2.00
Crystal Lake Drive	-----	-----	-----	-----	-----	-----	-----	-----	-----	-----
Conway Road	\$2.85	\$3.25	\$2.85	\$3.25	\$2.85	\$3.25	\$2.56	\$3.00	\$1.99	\$2.25
Andes Avenue	\$3.12	\$3.50	\$3.12	\$3.50	\$3.12	\$3.50	\$2.83	\$3.25	\$2.26	\$2.50
Semorán Boulevard (SR 436)	\$3.12	\$3.50	\$3.12	\$3.50	\$3.12	\$3.50	\$2.83	\$3.25	\$2.26	\$2.50
Yucatan Drive	-----	-----	-----	-----	-----	-----	-----	-----	-----	-----
Goldenrod Road	\$3.12	\$3.50	\$3.12	\$3.50	\$3.12	\$3.50	\$2.83	\$3.25	\$2.26	\$2.50
Chickasaw Trail	\$3.00	\$3.00	\$3.00	\$3.00	\$3.00	\$3.00	\$2.71	\$2.75	\$2.14	\$2.00
SR 417 (GreeneWay)	\$3.12	\$3.50	\$3.12	\$3.50	\$3.12	\$3.50	\$2.83	\$3.25	\$2.26	\$2.50
Dean Road	\$4.69	\$4.25	\$4.69	\$4.25	\$4.69	\$4.25	\$4.40	\$4.00	\$3.83	\$3.25
Rouse Road	\$3.98	\$4.50	\$3.98	\$4.50	\$3.98	\$4.50	\$3.69	\$4.25	\$3.12	\$3.50
Alafaya Trail	\$3.98	\$4.50	\$3.98	\$4.50	\$3.98	\$4.50	\$3.69	\$4.25	\$3.12	\$3.50
SR 50 (East Colonial Drive)	\$3.98	\$4.50	\$3.98	\$4.50	\$3.98	\$4.50	\$3.69	\$4.25	\$3.12	\$3.50



Toll Rates Between Interchanges (\$ Dollars) - 2 Axle Vehicles Only
SR 408 (East-West Expressway)

From	To									
	Pine Hills Road		OWG/Mercy/Ortman		John Young Parkway		Tampa Avenue		Orange Blossom Trail	
	E-PASS	CASH	E-PASS	CASH	E-PASS	CASH	E-PASS	CASH	E-PASS	CASH
Florida's Turnpike	-----	-----	-----	-----	\$1.99	\$2.25	\$1.99	\$2.25	\$1.99	\$2.25
SR 50/Clarke Road	-----	-----	-----	-----	\$1.99	\$2.25	\$1.99	\$2.25	\$1.99	\$2.25
Good Homes Road	-----	-----	-----	-----	\$1.99	\$2.25	\$1.99	\$2.25	\$1.99	\$2.25
Hiwassee Road	-----	-----	-----	-----	\$1.99	\$2.25	\$1.99	\$2.25	\$1.99	\$2.25
Kirkman Road	-----	-----	-----	-----	\$1.13	\$1.25	\$1.13	\$1.25	\$1.13	\$1.25
Pine Hills Road	-----	-----	-----	-----	\$1.13	\$1.25	\$1.13	\$1.25	\$1.13	\$1.25
Old Winter Garden/Mercy-Ortman Drive	-----	-----	-----	-----	\$1.13	\$1.25	\$1.13	\$1.25	\$0.86	\$1.00
John Young Parkway	\$1.13	\$1.25	\$0.86	\$1.00	-----	-----	\$0.86	\$1.00	\$0.86	\$1.00
Tampa Avenue	\$1.13	\$1.25	\$0.86	\$1.00	\$0.86	\$1.00	-----	-----	-----	-----
Orange Blossom Trail	\$1.13	\$1.25	\$0.86	\$1.00	\$0.86	\$1.00	-----	-----	-----	-----
Interstate 4 (I-4)	\$1.13	\$1.25	\$0.86	\$1.00	\$0.86	\$1.00	-----	-----	\$0.57	\$0.75
Orange Avenue	\$1.13	\$1.25	\$0.86	\$1.00	\$0.86	\$1.00	-----	-----	\$0.57	\$0.75
Rosalind Avenue	-----	-----	-----	-----	-----	-----	-----	-----	-----	-----
Mills Avenue	-----	-----	-----	-----	-----	-----	-----	-----	-----	-----
Bumby Avenue	\$1.70	\$2.00	\$1.43	\$1.75	\$1.43	\$1.75	-----	-----	\$1.14	\$1.50
Crystal Lake Drive	-----	-----	-----	-----	-----	-----	-----	-----	-----	-----
Conway Road	\$1.99	\$2.25	\$1.72	\$2.00	\$1.72	\$2.00	-----	-----	\$1.43	\$1.75
Andes Avenue	\$2.26	\$2.50	\$1.99	\$2.25	\$1.99	\$2.25	-----	-----	\$1.70	\$2.00
Semorán Boulevard (SR 436)	\$2.26	\$2.50	\$1.99	\$2.25	\$1.99	\$2.25	-----	-----	\$1.70	\$2.00
Yucatan Drive	-----	-----	-----	-----	-----	-----	-----	-----	-----	-----
Goldenrod Road	\$2.26	\$2.50	\$1.99	\$2.25	\$1.99	\$2.25	-----	-----	\$1.70	\$2.00
Chickasaw Trail	\$2.14	\$2.00	\$1.87	\$1.75	\$1.87	\$1.75	-----	-----	\$1.58	\$1.50
SR 417 (GreeneWay)	\$2.26	\$2.50	\$1.99	\$2.25	\$1.99	\$2.25	-----	-----	\$1.70	\$2.00
Dean Road	\$3.83	\$3.25	\$3.56	\$3.00	\$3.56	\$3.00	-----	-----	\$3.27	\$2.75
Rouse Road	\$3.12	\$3.50	\$2.85	\$3.25	\$2.85	\$3.25	-----	-----	\$2.56	\$3.00
Alafaya Trail	\$3.12	\$3.50	\$2.85	\$3.25	\$2.85	\$3.25	-----	-----	\$2.56	\$3.00
SR 50 (East Colonial Drive)	\$3.12	\$3.50	\$2.85	\$3.25	\$2.85	\$3.25	-----	-----	\$2.56	\$3.00



Toll Rates Between Interchanges (\$ Dollars) - 2 Axle Vehicles Only
SR 408 (East-West Expressway) - Continued

From	To									
	Interstate 4 (I-4)		Orange Avenue		Rosalind Avenue		Mills Avenue		Bumby Avenue	
	E-PASS	CASH	E-PASS	CASH	E-PASS	CASH	E-PASS	CASH	E-PASS	CASH
Florida's Turnpike	\$1.99	\$2.25	\$1.99	\$2.25					\$2.56	\$3.00
SR 50/Clarke Road	\$1.99	\$2.25	\$1.99	\$2.25					\$2.56	\$3.00
Good Homes Road	\$1.99	\$2.25	\$1.99	\$2.25					\$2.56	\$3.00
Hiwassee Road	\$1.99	\$2.25	\$1.99	\$2.25					\$2.56	\$3.00
Kirkman Road	\$1.13	\$1.25	\$1.13	\$1.25					\$1.70	\$2.00
Pine Hills Road	\$1.13	\$1.25	\$1.13	\$1.25					\$1.70	\$2.00
Old Winter Garden/Mercy-Ortman Drive	\$0.86	\$1.00	\$0.86	\$1.00					\$1.43	\$1.75
John Young Parkway	\$0.86	\$1.00	\$0.86	\$1.00					\$1.43	\$1.75
Tampa Avenue										
Orange Blossom Trail	\$0.57	\$0.75	\$0.57	\$0.75					\$1.14	\$1.50
Interstate 4 (I-4)			\$0.00	\$0.00					\$0.57	\$0.75
Orange Avenue										
Rosalind Avenue										
Mills Avenue										
Bumby Avenue	\$0.57	\$0.75			\$0.57	\$0.75			\$0.57	\$0.75
Crystal Lake Drive										
Conway Road	\$0.86	\$1.00			\$0.86	\$1.00				
Andes Avenue	\$1.13	\$1.25			\$1.13	\$1.25			\$1.13	\$1.25
Semorán Boulevard (SR 436)	\$1.13	\$1.25			\$1.13	\$1.25			\$1.13	\$1.25
Yucatan Drive										
Goldenrod Road	\$1.13	\$1.25			\$1.13	\$1.25			\$1.13	\$1.25
Chickasaw Trail	\$1.01	\$0.75			\$1.01	\$0.75			\$1.01	\$0.75
SR 417 (GreeneWay)	\$1.13	\$1.25			\$1.13	\$1.25			\$1.13	\$1.25
Dean Road	\$2.70	\$2.00			\$2.70	\$2.00			\$2.70	\$2.00
Rouse Road	\$1.99	\$2.25			\$1.99	\$2.25			\$1.99	\$2.25
Alafaya Trail	\$1.99	\$2.25			\$1.99	\$2.25			\$1.99	\$2.25
SR 50 (East Colonial Drive)	\$1.99	\$2.25			\$1.99	\$2.25			\$1.99	\$2.25



Toll Rates Between Interchanges (\$ Dollars) - 2 Axle Vehicles Only
SR 408 (East-West Expressway) - Continued

From	To											
	Crystal Lake Drive		Conway Road		Andes Avenue		Semoran Blvd.		Yucatan Drive		Goldenrod Road	
	E-PASS	CASH	E-PASS	CASH	E-PASS	CASH	E-PASS	CASH	E-PASS	CASH	E-PASS	CASH
Florida's Turnpike	---	---	\$2.85	\$3.25	\$3.98	\$4.50	---	---	---	---	\$5.11	\$5.75
SR 50/Clarke Road	---	---	\$2.85	\$3.25	\$3.98	\$4.50	---	---	---	---	\$5.11	\$5.75
Good Homes Road	---	---	\$2.85	\$3.25	\$3.98	\$4.50	---	---	---	---	\$5.11	\$5.75
Hiwassee Road	---	---	\$2.85	\$3.25	\$3.98	\$4.50	---	---	---	---	\$5.11	\$5.75
Kirkman Road	---	---	\$1.99	\$2.25	\$3.12	\$3.50	---	---	---	---	\$4.25	\$4.75
Pine Hills Road	---	---	\$1.99	\$2.25	\$3.12	\$3.50	---	---	---	---	\$4.25	\$4.75
Old Winter Garden/Mercy-Ortman Drive	---	---	\$1.72	\$2.00	\$2.85	\$3.25	---	---	---	---	\$3.98	\$4.50
John Young Parkway	---	---	\$1.72	\$2.00	\$2.85	\$3.25	---	---	---	---	\$3.98	\$4.50
Tampa Avenue	---	---	---	---	---	---	---	---	---	---	---	---
Orange Blossom Trail	---	---	\$1.43	\$1.75	\$2.56	\$3.00	---	---	---	---	\$3.69	\$4.25
Interstate 4 (I-4)	---	---	\$0.86	\$1.00	\$1.99	\$2.25	---	---	---	---	\$3.12	\$3.50
Orange Avenue	---	---	---	---	---	---	---	---	---	---	---	---
Rosalind Avenue	---	---	\$0.86	\$1.00	\$1.99	\$2.25	---	---	---	---	\$3.12	\$3.50
Mills Avenue	---	---	\$0.86	\$1.00	\$1.99	\$2.25	---	---	---	---	\$3.12	\$3.50
Bumby Avenue	---	---	---	---	---	---	---	---	---	---	---	---
Crystal Lake Drive	---	---	\$0.86	\$1.00	\$1.13	\$1.25	---	---	---	---	\$2.26	\$2.50
Conway Road	\$0.86	\$1.00	---	---	---	---	---	---	---	---	---	---
Andes Avenue	\$1.13	\$1.25	---	---	---	---	---	---	---	---	---	---
Semoran Boulevard (SR 436)	\$1.13	\$1.25	---	---	---	---	---	---	---	---	---	---
Yucatan Drive	---	---	---	---	---	---	---	---	---	---	---	---
Goldenrod Road	\$1.13	\$1.25	---	---	---	---	\$0.86	\$1.00	---	---	\$0.86	\$1.00
Chickasaw Trail	\$1.01	\$0.75	---	---	---	---	\$0.74	\$0.50	---	---	---	---
SR 417 (GreeneWay)	\$1.13	\$1.25	---	---	---	---	\$0.86	\$1.00	---	---	\$0.00	\$0.00
Dean Road	\$2.70	\$2.00	---	---	---	---	\$2.43	\$1.75	---	---	\$2.43	\$1.75
Rouse Road	\$1.99	\$2.25	---	---	---	---	\$1.72	\$2.00	---	---	\$1.72	\$2.00
Alafaya Trail	\$1.99	\$2.25	---	---	---	---	\$1.72	\$2.00	---	---	\$1.72	\$2.00
SR 50 (East Colonial Drive)	\$1.99	\$2.25	---	---	---	---	\$1.72	\$2.00	---	---	\$1.72	\$2.00



Toll Rates Between Interchanges (\$ Dollars) - 2 Axle Vehicles Only
SR 408 (East-West Expressway) - Continued

From	To											
	Chickasaw Trail		SR 417 (GreeneWay)		Dean Road		Rouse Road		Alafaya Trail		SR 50 (Colonial Dr.)	
	E-PASS	CASH	E-PASS	CASH	E-PASS	CASH	E-PASS	CASH	E-PASS	CASH	E-PASS	CASH
Florida's Turnpike	\$5.11	\$5.75	\$5.11	\$5.75	\$6.68	\$6.50	\$5.97	\$6.75	\$5.97	\$6.75	\$5.97	\$6.75
SR 50/Clarke Road	\$5.11	\$5.75	\$5.11	\$5.75	\$6.68	\$6.50	\$5.97	\$6.75	\$5.97	\$6.75	\$5.97	\$6.75
Good Homes Road	\$5.11	\$5.75	\$5.11	\$5.75	\$6.68	\$6.50	\$5.97	\$6.75	\$5.97	\$6.75	\$5.97	\$6.75
Hiwassee Road	\$5.11	\$5.75	\$5.11	\$5.75	\$6.68	\$6.50	\$5.97	\$6.75	\$5.97	\$6.75	\$5.97	\$6.75
Kirkman Road	\$4.25	\$4.75	\$4.25	\$4.75	\$5.82	\$5.50	\$5.11	\$5.75	\$5.11	\$5.75	\$5.11	\$5.75
Pine Hills Road	\$4.25	\$4.75	\$4.25	\$4.75	\$5.82	\$5.50	\$5.11	\$5.75	\$5.11	\$5.75	\$5.11	\$5.75
Old Winter Garden/Mercy-Ortman Drive	\$3.98	\$4.50	\$3.98	\$4.50	\$5.55	\$5.25	\$4.84	\$5.50	\$4.84	\$5.50	\$4.84	\$5.50
John Young Parkway	\$3.98	\$4.50	\$3.98	\$4.50	\$5.55	\$5.25	\$4.84	\$5.50	\$4.84	\$5.50	\$4.84	\$5.50
Tampa Avenue	-----	-----	-----	-----	-----	-----	-----	-----	-----	-----	-----	-----
Orange Blossom Trail	\$3.69	\$4.25	\$3.69	\$4.25	\$5.26	\$5.00	\$4.55	\$5.25	\$4.55	\$5.25	\$4.55	\$5.25
Interstate 4 (I-4)	\$3.12	\$3.50	\$3.12	\$3.50	\$4.69	\$4.25	\$3.98	\$4.50	\$3.98	\$4.50	\$3.98	\$4.50
Orange Avenue	-----	-----	-----	-----	-----	-----	-----	-----	-----	-----	-----	-----
Rosalind Avenue	\$3.12	\$3.50	\$3.12	\$3.50	\$4.69	\$4.25	\$3.98	\$4.50	\$3.98	\$4.50	\$3.98	\$4.50
Mills Avenue	\$3.12	\$3.50	\$3.12	\$3.50	\$4.69	\$4.25	\$3.98	\$4.50	\$3.98	\$4.50	\$3.98	\$4.50
Bumby Avenue	-----	-----	-----	-----	-----	-----	-----	-----	-----	-----	-----	-----
Crystal Lake Drive	\$2.26	\$2.50	\$2.26	\$2.50	\$3.83	\$3.25	\$3.12	\$3.50	\$3.12	\$3.50	\$3.12	\$3.50
Conway Road	-----	-----	-----	-----	-----	-----	-----	-----	-----	-----	-----	-----
Andes Avenue	-----	-----	-----	-----	-----	-----	-----	-----	-----	-----	-----	-----
Semorran Boulevard (SR 436)	-----	-----	-----	-----	-----	-----	-----	-----	-----	-----	-----	-----
Yucatan Drive	\$0.86	\$1.00	\$0.86	\$1.00	\$2.43	\$1.75	\$1.72	\$2.00	\$1.72	\$2.00	\$1.72	\$2.00
Goldenrod Road	-----	-----	\$0.00	\$0.00	\$1.57	\$0.75	\$0.86	\$1.00	\$0.86	\$1.00	\$0.86	\$1.00
Chickasaw Trail	-----	-----	-----	-----	-----	-----	-----	-----	-----	-----	-----	-----
SR 417 (GreeneWay)	-----	-----	-----	-----	\$1.57	\$0.75	\$0.86	\$1.00	\$0.86	\$1.00	\$0.86	\$1.00
Dean Road	-----	-----	\$2.43	\$1.75	-----	-----	\$0.86	\$1.00	\$0.86	\$1.00	\$0.86	\$1.00
Rouse Road	-----	-----	\$1.72	\$2.00	\$1.72	\$2.00	-----	-----	-----	-----	\$0.57	\$0.75
Alafaya Trail	-----	-----	\$1.72	\$2.00	\$1.72	\$2.00	\$0.57	\$0.75	-----	-----	-----	-----
SR 50 (East Colonial Drive)	-----	-----	\$1.72	\$2.00	\$1.72	\$2.00	\$0.00	\$0.00	-----	-----	-----	-----



Toll Rates Between Interchanges (\$ Dollars) - 2 Axle Vehicles Only
SR 408 (East-West Expressway) - Continued

From	To									
	Boggy Creek Rd.		Tradeport/Conway		Semoran Blvd/Airport		Goldenrod Road		Narcoossee Road	
	E-PASS	CASH	E-PASS	CASH	E-PASS	CASH	E-PASS	CASH	E-PASS	CASH
US 441/Florida's Turnpike	\$1.13	\$1.25	\$1.13	\$1.00	\$1.13	\$1.00	\$1.13	\$1.00	\$1.13	\$1.00
Boggy Creek Road	-----	-----	\$1.13	\$1.25	\$1.13	\$1.25	\$1.13	\$1.25	\$1.13	\$1.25
Tradeport Drive/Conway Road	\$1.13	\$1.25	-----	-----	\$1.13	\$1.25	\$1.13	\$1.25	\$1.13	\$1.25
Semoran Boulevard/Airport	\$1.13	\$1.25	\$1.13	\$1.25	-----	-----	\$0.00	\$0.00	\$0.00	\$0.00
Goldenrod Road	\$1.13	\$1.25	\$1.13	\$1.25	\$0.00	\$0.00	-----	-----	\$0.00	\$0.00
Narcoossee Road	\$1.13	\$1.25	\$1.13	\$1.25	\$0.00	\$0.00	\$0.00	\$0.00	-----	-----
SR 417 (GreeneWay)	\$1.13	\$1.25	\$1.13	\$1.25	\$0.00	\$0.00	\$0.00	\$0.00	\$0.00	\$0.00
Innovation Way	\$2.04	\$2.50	\$2.04	\$2.50	\$0.91	\$1.25	\$0.91	\$1.25	\$0.91	\$1.25
Dallas Boulevard	\$2.56	\$3.25	\$2.56	\$3.25	\$1.43	\$2.00	\$1.43	\$2.00	\$1.43	\$2.00
SR 520	\$2.56	\$3.25	\$2.56	\$3.25	\$1.43	\$2.00	\$1.43	\$2.00	\$1.43	\$2.00
Brevard County Line	\$2.56	\$3.25	\$2.56	\$3.25	\$1.43	\$2.00	\$1.43	\$2.00	\$1.43	\$2.00

From	To									
	SR 417 (GreeneWay)		Innovation Way		Dallas Boulevard		SR 520		Brevard County Line	
	E-PASS	CASH	E-PASS	CASH	E-PASS	CASH	E-PASS	CASH	E-PASS	CASH
US 441/Florida's Turnpike	\$1.13	\$1.00	\$2.04	\$2.25	\$2.56	\$3.00	\$2.56	\$3.00	\$2.56	\$3.00
Boggy Creek Road	\$1.13	\$1.25	\$2.04	\$2.50	\$2.56	\$3.25	\$3.08	\$4.00	\$3.08	\$4.00
Tradeport Drive/Conway Road	\$1.13	\$1.25	\$2.04	\$2.50	\$2.56	\$3.25	\$2.56	\$3.25	\$2.56	\$3.25
Semoran Boulevard/Airport	\$0.00	\$0.00	\$0.91	\$1.25	\$1.43	\$2.00	\$1.43	\$2.00	\$1.43	\$2.00
Goldenrod Road	\$0.00	\$0.00	\$0.91	\$1.25	\$1.43	\$2.00	\$1.43	\$2.00	\$1.43	\$2.00
Narcoossee Road	\$0.00	\$0.00	\$0.91	\$1.25	\$1.43	\$2.00	\$1.43	\$2.00	\$1.43	\$2.00
SR 417 (GreeneWay)	-----	-----	-----	-----	\$0.52	\$0.75	-----	-----	-----	-----
Innovation Way	\$0.91	\$1.25	-----	-----	\$0.52	\$0.75	-----	-----	-----	-----
Dallas Boulevard	\$1.43	\$2.00	\$0.52	\$0.75	-----	-----	-----	-----	-----	-----
SR 520	\$1.43	\$2.00	\$0.52	\$0.75	-----	-----	-----	-----	\$0.26	\$0.50
Brevard County Line	\$1.43	\$2.00	\$0.52	\$0.75	-----	-----	\$0.26	\$0.50	-----	-----



Toll Rates Between Interchanges (\$ Dollars) - 2 Axle Vehicles Only
SR 528 (Beachline Expressway)

From	To											
	International Drive		John Young Parkway		Orange Blossom Trail		Florida's Turnpike		Landstar Boulevard			
	E-PASS	CASH	E-PASS	CASH	E-PASS	CASH	E-PASS	CASH	E-PASS	CASH		
International Drive	-----	-----	\$1.43	\$1.75	\$1.43	\$1.75	\$1.43	\$1.75	\$1.93	\$2.25		
John Young Parkway	\$1.43	\$1.75	-----	-----	\$0.86	\$1.00	\$0.86	\$1.00	\$1.36	\$1.50		
Orange Blossom Trail	\$1.43	\$1.75	\$0.86	\$1.00	-----	-----	\$0.86	\$1.00	\$1.36	\$1.50		
Florida's Turnpike	-----	-----	-----	-----	-----	-----	-----	-----	\$0.50	\$0.50		
Landstar Boulevard	\$1.93	\$2.25	\$1.36	\$1.50	\$1.07	\$1.25	\$0.50	\$0.50	-----	-----		
South Access Road (Int'l Airport)	\$2.86	\$3.50	\$2.29	\$2.75	\$2.00	\$2.50	\$1.43	\$1.75	\$1.43	\$1.75		
Boggy Creek Road	\$2.86	\$3.50	\$2.29	\$2.75	\$2.00	\$2.50	\$1.43	\$1.75	\$1.43	\$1.75		
Lake Nona Boulevard	\$2.86	\$3.50	\$2.29	\$2.75	\$2.00	\$2.50	\$1.43	\$1.75	\$1.43	\$1.75		
Narcoossee Road	\$2.86	\$3.50	\$2.29	\$2.75	\$2.00	\$2.50	\$1.43	\$1.75	\$1.43	\$1.75		
Moss Park Road	\$2.86	\$3.50	\$2.29	\$2.75	\$2.00	\$2.50	\$1.43	\$1.75	\$1.43	\$1.75		
Dowden Road	\$2.86	\$3.50	\$2.29	\$2.75	\$2.00	\$2.50	\$1.43	\$1.75	\$1.43	\$1.75		
SR 528 (Beachline Expressway)	\$2.86	\$3.50	\$2.29	\$2.75	\$2.00	\$2.50	\$1.43	\$1.75	\$1.43	\$1.75		
Lee Vista Boulevard	\$3.43	\$4.25	\$2.86	\$3.50	\$2.57	\$3.25	\$2.00	\$2.50	\$2.00	\$2.50		
Curry Ford Road	\$3.72	\$4.50	\$3.15	\$3.75	\$2.86	\$3.50	\$2.29	\$2.75	\$2.29	\$2.75		
SR 408 (East-West Expressway)	\$3.72	\$4.50	\$3.15	\$3.75	\$2.86	\$3.50	\$2.29	\$2.75	\$2.29	\$2.75		
SR 50 (Colonial Drive)	\$4.29	\$5.25	\$3.72	\$4.50	\$3.43	\$4.25	\$2.86	\$3.50	\$2.86	\$3.50		
University Boulevard	\$4.58	\$5.50	\$4.01	\$4.75	\$3.72	\$4.50	\$3.15	\$3.75	\$3.15	\$3.75		
Aloma Avenue	\$4.83	\$5.75	\$4.26	\$5.00	\$3.97	\$4.75	\$3.40	\$4.00	\$3.40	\$4.00		



**Toll Rates Between Interchanges (\$ Dollars) - 2 Axle Vehicles Only
SR 417 (Central Florida GreeneWay)**

From	To											
	South Access (Airport)		Boggy Creek Road		Lake Nona Boulevard		Narcoossee Road		Moss Park Road			
	E-PASS	CASH	E-PASS	CASH	E-PASS	CASH	E-PASS	CASH	E-PASS	CASH		
International Drive	\$2.86	\$3.50	\$2.86	\$3.50	\$2.86	\$3.50	\$2.86	\$3.50	\$2.86	\$3.50		
John Young Parkway	\$2.29	\$2.75	\$2.29	\$2.75	\$2.29	\$2.75	\$2.29	\$2.75	\$2.29	\$2.75		
Orange Blossom Trail	\$2.29	\$2.75	\$2.29	\$2.75	\$2.29	\$2.75	\$2.29	\$2.75	\$2.29	\$2.75		
Florida's Turnpike	\$1.43	\$1.75	\$1.43	\$1.75	\$1.43	\$1.75	\$1.43	\$1.75	\$1.43	\$1.75		
Landstar Boulevard	\$1.43	\$1.75	\$1.43	\$1.75	\$1.43	\$1.75	\$1.43	\$1.75	\$1.43	\$1.75		
South Access Road (Int'l Airport)	-----	-----	-----	-----	-----	-----	-----	-----	-----	-----		
Boggy Creek Road	-----	-----	-----	-----	-----	-----	-----	-----	-----	-----		
Lake Nona Boulevard	\$1.13	\$1.25	\$1.13	\$1.25	\$1.13	\$1.25	\$1.13	\$1.25	\$1.13	\$1.25		
Narcoossee Road	\$1.13	\$1.25	\$1.13	\$1.25	\$1.13	\$1.25	\$1.13	\$1.25	\$1.13	\$1.25		
Moss Park Road	\$1.13	\$1.25	\$1.13	\$1.25	\$1.13	\$1.25	\$1.13	\$1.25	\$1.13	\$1.25		
Dowden Road	\$1.13	\$1.25	\$1.13	\$1.25	\$1.13	\$1.25	\$1.13	\$1.25	\$1.13	\$1.25		
SR 528 (Beachline Expressway)	\$1.13	\$1.25	\$1.13	\$1.25	\$1.13	\$1.25	\$1.13	\$1.25	\$1.13	\$1.25		
Lee Vista Boulevard	\$1.70	\$2.00	\$1.70	\$2.00	\$1.43	\$1.75	\$1.43	\$1.75	\$1.14	\$1.50		
Curry Ford Road	\$1.99	\$2.25	\$1.99	\$2.25	\$1.72	\$2.00	\$1.72	\$2.00	\$1.43	\$1.75		
SR 408 (East-West Expressway)	\$1.99	\$2.25	\$1.99	\$2.25	\$1.72	\$2.00	\$1.72	\$2.00	\$1.43	\$1.75		
SR 50 (Colonial Drive)	\$2.56	\$3.00	\$2.56	\$3.00	\$2.29	\$2.75	\$2.29	\$2.75	\$2.00	\$2.50		
University Boulevard	\$2.85	\$3.25	\$2.85	\$3.25	\$2.58	\$3.00	\$2.58	\$3.00	\$2.29	\$2.75		
Aloma Avenue	\$3.10	\$3.50	\$3.10	\$3.50	\$2.83	\$3.25	\$2.83	\$3.25	\$2.54	\$3.00		



**Toll Rates Between Interchanges (\$ Dollars) - 2 Axle Vehicles Only
SR 417 (Central Florida GreeneWay) - Continued**

From	To									
	Dowden Road		SR 528 (Beachline)		Lee Vista Boulevard		Curry Ford Road			
	E-PASS	CASH	E-PASS	CASH	E-PASS	CASH	E-PASS	CASH	E-PASS	CASH
International Drive	\$2.86	\$3.50	\$2.86	\$3.50	\$3.43	\$4.25	\$3.72	\$4.50		
John Young Parkway	\$2.29	\$2.75	\$2.29	\$2.75	\$2.86	\$3.50	\$3.15	\$3.75		
Orange Blossom Trail	\$2.29	\$2.75	\$2.29	\$2.75	\$2.86	\$3.50	\$3.15	\$3.75		
Florida's Turnpike	\$1.43	\$1.75	\$1.43	\$1.75	\$2.00	\$2.50	\$2.29	\$2.75		
Landstar Boulevard	\$1.43	\$1.75	\$1.43	\$1.75	\$2.00	\$2.50	\$2.29	\$2.75		
South Access Road (Int'l Airport)	\$1.13	\$1.25	\$1.13	\$1.25	\$1.70	\$2.00	\$1.99	\$2.25		
Boggy Creek Road	\$1.13	\$1.25	\$1.13	\$1.25	\$1.70	\$2.00	\$1.99	\$2.25		
Lake Nona Boulevard	\$0.86	\$1.00	\$0.86	\$1.00	\$1.43	\$1.75	\$1.72	\$2.00		
Narcoossee Road	\$0.86	\$1.00	\$0.86	\$1.00	\$1.43	\$1.75	\$1.72	\$2.00		
Moss Park Road	\$0.57	\$0.75	\$0.57	\$0.75	\$1.14	\$1.50	\$1.43	\$1.75		
Dowden Road	-----	-----	\$0.57	\$0.75	\$1.14	\$1.50	\$1.43	\$1.75		
SR 528 (Beachline Expressway)	\$0.57	\$0.75	-----	-----	\$0.57	\$0.75	\$0.86	\$1.00		
Lee Vista Boulevard	\$1.14	\$1.50	\$0.57	\$0.75	-----	-----	\$0.86	\$1.00		
Curry Ford Road	\$1.43	\$1.75	\$0.86	\$1.00	\$0.86	\$1.00	-----	-----		
SR 408 (East-West Expressway)	\$1.43	\$1.75	\$0.86	\$1.00	\$0.86	\$1.00	\$0.57	\$0.75		
SR 50 (Colonial Drive)	\$2.00	\$2.50	\$1.43	\$1.75	\$1.43	\$1.75	\$1.14	\$1.50		
University Boulevard	\$2.29	\$2.75	\$1.72	\$2.00	\$1.72	\$2.00	\$1.43	\$1.75		
Aloma Avenue	\$2.54	\$3.00	\$1.97	\$2.25	\$1.97	\$2.25	\$1.68	\$2.00		



**Toll Rates Between Interchanges (\$ Dollars) - 2 Axle Vehicles Only
SR 417 (Central Florida GreeneWay) - Continued**

From	To									
	SR 408 (East West)		SR 50 (Colonial Dr.)		University Boulevard		Aloma Avenue			
	E-PASS	CASH	E-PASS	CASH	E-PASS	CASH	E-PASS	CASH		
International Drive	\$3.72	\$4.50	\$4.29	\$5.25	\$4.58	\$5.50	\$4.29	\$5.25		
John Young Parkway	\$3.15	\$3.75	\$3.72	\$4.50	\$4.01	\$4.75	\$3.72	\$4.50		
Orange Blossom Trail	\$3.15	\$3.75	\$3.72	\$4.50	\$4.01	\$4.75	\$3.72	\$4.50		
Florida's Turnpike	\$2.29	\$2.75	\$2.86	\$3.50	\$3.15	\$3.75	\$2.86	\$3.50		
Landstar Boulevard	\$2.29	\$2.75	\$2.86	\$3.50	\$3.15	\$3.75	\$2.86	\$3.50		
South Access Road (Int'l Airport)	\$1.99	\$2.25	\$2.56	\$3.00	\$2.85	\$3.25	\$2.56	\$3.00		
Boggy Creek Road	\$1.99	\$2.25	\$2.56	\$3.00	\$2.85	\$3.25	\$2.56	\$3.00		
Lake Nona Boulevard	\$1.72	\$2.00	\$2.29	\$2.75	\$2.58	\$3.00	\$2.29	\$2.75		
Narcoossee Road	\$1.72	\$2.00	\$2.29	\$2.75	\$2.58	\$3.00	\$2.29	\$2.75		
Moss Park Road	\$1.43	\$1.75	\$2.00	\$2.50	\$2.29	\$2.75	\$2.00	\$2.50		
Dowden Road	\$1.43	\$1.75	\$2.00	\$2.50	\$2.29	\$2.75	\$2.00	\$2.50		
SR 528 (Beachline Expressway)	\$0.86	\$1.00	\$1.43	\$1.75	\$1.72	\$2.00	\$1.43	\$1.75		
Lee Vista Boulevard	\$0.86	\$1.00	\$1.43	\$1.75	\$1.72	\$2.00	\$1.43	\$1.75		
Curry Ford Road	\$0.86	\$1.00	\$1.43	\$1.75	\$1.72	\$2.00	\$1.43	\$1.75		
SR 408 (East-West Expressway)	-----	-----	\$0.57	\$0.75	\$0.86	\$1.00	\$0.57	\$0.75		
SR 50 (Colonial Drive)	\$0.85	\$1.25	-----	-----	\$0.86	\$1.00	\$0.57	\$0.75		
University Boulevard	\$1.14	\$1.50	\$1.14	\$1.50	-----	-----	\$0.57	\$0.75		
Aloma Avenue	\$1.39	\$1.75	\$1.39	\$1.75	\$0.57	\$0.75	-----	-----		



**Toll Rates Between Interchanges (\$ Dollars) - 2 Axle Vehicles Only
SR 417 (Central Florida GreeneWay) - Continued**

From	To											
	Seidel Road		Schofield Road		New Independence Pkwy		CR 535		Florida's Turnpike			
	E-PASS	CASH	E-PASS	CASH	E-PASS	CASH	E-PASS	CASH	E-PASS	CASH		
Seidel Road	-----	-----	-----	-----	-----	-----	-----	-----	-----	-----	-----	-----
Schofield Road	-----	-----	-----	-----	\$0.86	\$1.00	\$1.43	\$1.40	\$1.43	\$1.43	\$1.43	\$1.50
New Independence Parkway	-----	-----	\$0.86	\$1.00	-----	-----	\$1.43	\$1.40	\$1.43	\$1.37	\$1.40	\$1.50
CR 535 (Old Winter Garden)	-----	-----	\$1.43	\$1.75	\$1.43	\$1.75	-----	-----	-----	\$0.57	-----	\$0.75
Florida's Turnpike (SR 91)	-----	-----	\$1.43	\$1.75	\$1.43	\$1.75	\$0.57	\$0.75	\$0.57	-----	\$0.75	-----
SR 50 (West Colonial Drive)	-----	-----	\$1.43	\$1.75	\$1.43	\$1.75	\$0.57	\$0.75	\$0.57	-----	\$0.75	-----
Plant Street/Franklin Street/SR 438	-----	-----	\$1.73	\$2.25	\$1.73	\$2.25	\$0.87	\$1.25	\$0.87	\$0.30	\$1.25	\$0.50
West Road	-----	-----	\$2.29	\$2.75	\$2.29	\$2.75	\$1.43	\$1.75	\$1.43	\$0.86	\$1.75	\$1.00
CR 437A (Ocoee Apopka Road)	-----	-----	\$2.86	\$3.50	\$2.86	\$3.50	\$2.00	\$2.50	\$2.00	\$1.43	\$2.50	\$1.75
SR 414 (Apopka Expressway)	-----	-----	\$2.86	\$3.50	\$2.86	\$3.50	\$2.00	\$2.50	\$2.00	\$1.43	\$2.50	\$1.75
SR 429 Connector Road	-----	-----	\$2.86	\$3.50	\$2.86	\$3.50	\$2.00	\$2.50	\$2.00	\$1.43	\$2.50	\$1.75
Kelly Park Road	-----	-----	\$3.68	\$4.91	\$3.68	\$4.91	\$2.82	\$3.91	\$2.82	\$2.25	\$3.91	\$3.16
SR 453	-----	-----	\$3.68	\$4.91	\$3.68	\$4.91	\$2.82	\$3.91	\$2.82	\$2.25	\$3.91	\$3.16
SR 46	-----	-----	\$4.45	\$6.27	\$4.45	\$6.27	\$3.59	\$5.27	\$3.59	\$3.02	\$5.27	\$4.52

Note:

1. For cash traffic passing through Ponkan and Mount Plymouth Mainline Gantry it is assumed Pay-By-Plate is used.



**Toll Rates Between Interchanges (\$ Dollars) - 2 Axle Vehicles Only
SR 429 (Western Beltway)**

From	To											
	SR 50 (Colonial Dr.)		Plant/Franklin St		West Road		CR 437A		SR 414 (Apopka Expwy)			
	E-PASS	CASH	E-PASS	CASH	E-PASS	CASH	E-PASS	CASH	E-PASS	CASH		
Seidel Road	-----	-----	-----	-----	-----	-----	-----	-----	-----	-----	-----	-----
Schofield Road	\$1.43	\$1.50	\$1.73	\$2.00	\$2.29	\$2.50	\$2.85	\$3.00	\$2.85	\$3.00	\$2.85	\$3.00
New Independence Parkway	\$1.37	\$1.50	\$1.67	\$2.00	\$2.23	\$2.50	\$2.79	\$3.00	\$2.79	\$3.00	\$2.79	\$3.00
CR 535 (Old Winter Garden)	\$0.57	\$0.75	\$0.87	\$1.25	\$1.43	\$1.75	\$1.99	\$2.25	\$1.99	\$2.25	\$1.99	\$2.25
Florida's Turnpike (SR 91)	-----	-----	\$0.30	\$0.50	\$0.86	\$1.00	\$1.42	\$1.50	\$1.42	\$1.50	\$1.42	\$1.50
SR 50 (West Colonial Drive)	-----	-----	\$0.30	\$0.50	\$0.86	\$1.00	\$1.42	\$1.50	\$1.42	\$1.50	\$1.42	\$1.50
Plant Street/Franklin Street/SR 438	\$0.30	\$0.50	-----	-----	\$0.86	\$1.00	\$1.42	\$1.50	\$1.42	\$1.50	\$1.42	\$1.50
West Road	\$0.86	\$1.00	\$0.86	\$1.00	-----	-----	\$0.57	\$0.75	\$0.57	\$0.75	\$0.57	\$0.75
CR 437A (Ocoee Apopka Road)	\$1.43	\$1.75	\$1.43	\$1.75	\$1.43	\$1.75	\$1.75	-----	-----	-----	-----	-----
SR 414 (Apopka Expressway)	\$1.43	\$1.75	\$1.43	\$1.75	\$1.43	\$1.75	\$1.75	\$0.75	\$0.57	\$0.75	\$0.57	\$0.75
SR 429 Connector Road	\$1.43	\$1.75	\$1.43	\$1.75	\$1.43	\$1.75	\$1.75	\$0.75	\$0.57	\$0.75	\$0.57	\$0.75
Kelly Park Road	\$2.25	\$3.16	\$2.25	\$3.16	\$2.25	\$3.16	\$2.25	\$2.16	\$1.39	\$2.16	\$1.39	\$2.16
SR 453	\$2.25	\$3.16	\$2.25	\$3.16	\$2.25	\$3.16	\$2.25	\$2.16	\$1.39	\$2.16	\$1.39	\$2.16
SR 46	\$3.02	\$4.52	\$3.02	\$4.52	\$3.02	\$4.52	\$3.02	\$3.52	\$2.16	\$3.52	\$2.16	\$3.52

Notes:

1. For cash traffic passing through Ponkan and Mount Plymouth Mainline Gantry it is assumed Pay-By-Plate is used.



Toll Rates Between Interchanges (\$ Dollars) - 2 Axle Vehicles Only
SR 429 (Western Beltway)

From	To									
	SR 429 Connector Rd.		Kelly Park Road		SR 429/453 System Int		SR 46			
	E-PASS	CASH	E-PASS	CASH	E-PASS	CASH	E-PASS	CASH		
Seidel Road	-----	-----	-----	-----	-----	-----	-----	-----	-----	
Schofield Road	\$2.85	\$3.00	\$3.67	\$3.82	\$4.49	\$4.64	\$5.31	\$5.46		
New Independence Parkway	\$2.79	\$3.00	\$3.61	\$3.82	\$4.43	\$4.64	\$5.25	\$5.46		
CR 535 (Old Winter Garden)	\$1.99	\$2.25	\$2.81	\$3.07	\$3.63	\$3.89	\$4.45	\$4.71		
Florida's Turnpike (SR 91)	\$1.42	\$1.50	\$2.24	\$2.32	\$3.06	\$3.14	\$3.88	\$3.96		
SR 50 (West Colonial Drive)	\$1.42	\$1.50	\$2.24	\$2.32	\$3.06	\$3.14	\$3.88	\$3.96		
Plant Street/Franklin Street/SR 438	\$1.42	\$1.50	\$2.24	\$2.32	\$3.06	\$3.14	\$3.88	\$3.96		
West Road	\$0.57	\$0.75	\$1.39	\$1.57	\$2.21	\$2.39	\$3.03	\$3.21		
CR 437A (Ocoee Apopka Road)	\$0.57	\$0.75	\$1.39	\$1.57	\$2.21	\$2.39	\$3.03	\$3.21		
SR 414 (Apopka Expressway)	\$0.00	\$0.00	\$0.82	\$0.82	\$1.64	\$1.64	\$2.46	\$2.46		
SR 429 Connector Road	-----	-----	\$0.82	\$0.82	\$1.64	\$1.64	\$2.46	\$2.46		
Kelly Park Road	\$1.39	\$2.16	-----	-----	\$0.82	\$0.82	\$1.64	\$1.64		
SR 453	\$1.39	\$2.16	\$0.82	\$1.41	-----	-----	\$0.77	\$1.36		
SR 46	\$2.16	\$3.52	\$0.77	\$1.36	\$0.77	\$1.36	-----	-----		

Notes:

1. For cash traffic passing through Ponkan and Mount Plymouth Mainline Gantry it is assumed Pay-By-Plate is used.

Distance From	To							
	SR 429 Connector Rd.		SR 451		Marden Road		Keene Road	
	E-PASS	CASH	E-PASS	CASH	E-PASS	CASH	E-PASS	CASH
SR 429 Connector Road	-----	-----	-----	-----	-----	-----	-----	-----
SR 451 (Western Beltway)	-----	-----	-----	-----	-----	-----	-----	-----
Marden Road	-----	-----	-----	-----	-----	-----	-----	-----
Keene Road	-----	-----	-----	-----	-----	-----	-----	-----
Hiawassee Road (CR 435)	\$1.13	\$1.25	\$1.13	\$1.25	\$1.13	\$1.25	\$0.57	\$0.75
OBT - US 441 (East)	\$1.13	\$1.25	\$1.13	\$1.25	\$1.13	\$1.25	\$0.57	\$0.75
Bear Lake Road/Rose Avenue	\$1.13	\$1.25	\$1.13	\$1.25	\$1.13	\$1.25	\$0.57	\$0.75

Distance From	To							
	Hiawassee Road		OBT - US 441 (East)		Bear Lake/Rose Ave.			
	E-PASS	CASH	E-PASS	CASH	E-PASS	CASH	E-PASS	CASH
SR 429 Connector Road	\$1.13	\$1.25	\$1.13	\$1.25	\$1.13	\$1.25	\$1.13	\$1.25
SR 451 (Western Beltway)	\$1.13	\$1.25	\$1.13	\$1.25	\$1.13	\$1.25	\$1.13	\$1.25
Marden Road	\$1.13	\$1.25	\$1.13	\$1.25	\$1.13	\$1.25	\$1.13	\$1.25
Keene Road	\$0.57	\$0.75	\$0.57	\$0.75	\$0.57	\$0.75	\$0.57	\$0.75
Hiawassee Road (CR 435)	-----	-----	\$0.30	\$0.50	-----	-----	\$0.30	\$0.50
OBT - US 441 (East)	\$0.30	\$0.50	-----	-----	-----	-----	\$0.00	\$0.00
Bear Lake Road/Rose Avenue	\$0.30	\$0.50	\$0.00	\$0.00	\$0.00	\$0.00	-----	-----



Toll Rates Between Interchanges (\$ Dollars) - 2 Axle Vehicles Only
SR 414 (Apopka Expressway)

Distance From	To			
	SR 429/453 System Int		SR 46	
	E-PASS	CASH	E-PASS	CASH
SR 429/453 System Interchange	----- \$0.66	----- \$1.25	\$0.66	\$1.25
SR 46	----- \$0.66	----- \$1.25	----- \$0.66	----- \$1.25



Toll Rates Between Interchanges (\$ Dollars) - 2 Axle Vehicles Only
SR 453

Cost Per Mile Between Interchanges



2018 Traffic Data and Statistics Manual
CENTRAL FLORIDA EXPRESSWAY AUTHORITY

From	To											
	Florida's Turnpike		SR 50/ Clarke Road		Good Homes Road		Hiwassee Road		Kirkman Road			
	E-PASS	CASH	E-PASS	CASH	E-PASS	CASH	E-PASS	CASH	E-PASS	CASH		
Florida's Turnpike	-----	-----	-----	-----	\$0.18	\$0.32	\$0.26	\$0.30	\$0.19	\$0.22		
SR 50/Clarke Road	-----	-----	-----	-----	\$0.40	\$0.71	\$0.35	\$0.40	\$0.24	\$0.27		
Good Homes Road	\$0.18	\$0.32	\$0.40	\$0.71	-----	-----	-----	\$0.56	\$0.29	\$0.34		
Hiwassee Road	\$0.17	\$0.22	\$0.23	\$0.30	\$0.32	\$0.42	-----	-----	\$0.74	\$0.86		
Kirkman Road	\$0.19	\$0.22	\$0.24	\$0.27	\$0.29	\$0.34	\$0.49	\$0.65	-----	-----		
Pine Hills Road	-----	-----	-----	-----	-----	-----	-----	-----	-----	-----		
Old Winter Garden/Mercy-Ortman Drive	-----	-----	-----	-----	-----	-----	-----	-----	-----	-----		
John Young Parkway	\$0.27	\$0.31	\$0.31	\$0.35	\$0.35	\$0.40	\$0.43	\$0.51	\$0.41	\$0.45		
Tampa Avenue	\$0.25	\$0.28	\$0.28	\$0.32	\$0.31	\$0.35	\$0.37	\$0.44	\$0.33	\$0.37		
Orange Blossom Trail	\$0.24	\$0.27	\$0.26	\$0.30	\$0.29	\$0.33	\$0.33	\$0.39	\$0.29	\$0.32		
Interstate 4 (I-4)	\$0.22	\$0.25	\$0.24	\$0.28	\$0.27	\$0.30	\$0.30	\$0.35	\$0.25	\$0.28		
Orange Avenue	\$0.21	\$0.23	\$0.23	\$0.26	\$0.25	\$0.28	\$0.27	\$0.32	\$0.22	\$0.25		
Rosalind Avenue	-----	-----	-----	-----	-----	-----	-----	-----	-----	-----		
Mills Avenue	-----	-----	-----	-----	-----	-----	-----	-----	-----	-----		
Bumby Avenue	\$0.23	\$0.27	\$0.25	\$0.29	\$0.27	\$0.31	\$0.29	\$0.35	\$0.25	\$0.30		
Crystal Lake Drive	-----	-----	-----	-----	-----	-----	-----	-----	-----	-----		
Conway Road	\$0.23	\$0.26	\$0.25	\$0.28	\$0.26	\$0.30	\$0.28	\$0.33	\$0.25	\$0.28		
Andes Avenue	\$0.24	\$0.26	\$0.25	\$0.28	\$0.27	\$0.30	\$0.29	\$0.33	\$0.26	\$0.29		
Semorán Boulevard (SR 436)	\$0.23	\$0.25	\$0.24	\$0.27	\$0.26	\$0.29	\$0.27	\$0.31	\$0.24	\$0.27		
Yucatan Drive	-----	-----	-----	-----	-----	-----	-----	-----	-----	-----		
Goldenrod Road	\$0.20	\$0.23	\$0.22	\$0.24	\$0.23	\$0.26	\$0.24	\$0.27	\$0.21	\$0.23		
Chickasaw Trail	\$0.19	\$0.19	\$0.20	\$0.20	\$0.21	\$0.21	\$0.22	\$0.22	\$0.19	\$0.18		
SR 417 (GreeneWay)	\$0.18	\$0.20	\$0.19	\$0.21	\$0.20	\$0.22	\$0.20	\$0.23	\$0.18	\$0.20		
Dean Road	\$0.26	\$0.24	\$0.27	\$0.25	\$0.28	\$0.26	\$0.30	\$0.27	\$0.28	\$0.24		
Rouse Road	\$0.21	\$0.23	\$0.22	\$0.24	\$0.22	\$0.25	\$0.23	\$0.27	\$0.21	\$0.24		
Alafaya Trail	\$0.19	\$0.22	\$0.20	\$0.23	\$0.21	\$0.24	\$0.21	\$0.25	\$0.19	\$0.22		
SR 50 (East Colonial Drive)	\$0.18	\$0.20	\$0.19	\$0.21	\$0.19	\$0.22	\$0.20	\$0.23	\$0.18	\$0.20		



Toll Rates Between Interchanges (\$ Toll Rate/Mile) - 2 Axle Vehicles Only
SR 408 (East-West Expressway)

From	To									
	Pine Hills Road		OWG/Mercy/Ortman		John Young Parkway		Tampa Avenue		Orange Blossom Trail	
	E-PASS	CASH	E-PASS	CASH	E-PASS	CASH	E-PASS	CASH	E-PASS	CASH
Florida's Turnpike					\$0.27	\$0.31	\$0.25	\$0.28	\$0.24	\$0.27
SR 50/Clarke Road					\$0.31	\$0.35	\$0.28	\$0.32	\$0.26	\$0.30
Good Homes Road					\$0.35	\$0.40	\$0.31	\$0.35	\$0.29	\$0.33
Hiwassee Road					\$0.51	\$0.57	\$0.43	\$0.49	\$0.39	\$0.44
Kirkman Road					\$0.41	\$0.45	\$0.33	\$0.37	\$0.29	\$0.32
Pine Hills Road					\$0.52	\$0.58	\$0.40	\$0.44	\$0.34	\$0.37
Old Winter Garden/Mercy-Ortman Drive					\$1.05	\$1.16	\$0.49	\$0.57	\$0.38	\$0.44
John Young Parkway	\$0.52	\$0.58	\$0.80	\$0.93			\$1.30	\$1.51	\$0.73	\$0.85
Tampa Avenue	\$0.40	\$0.44	\$0.49	\$0.57	\$1.30	\$1.51				
Orange Blossom Trail	\$0.34	\$0.37	\$0.38	\$0.44	\$0.73	\$0.85				
Interstate 4 (I-4)	\$0.29	\$0.32	\$0.30	\$0.35	\$0.49	\$0.57			\$1.00	\$1.32
Orange Avenue	\$0.25	\$0.28	\$0.25	\$0.29	\$0.37	\$0.43			\$0.49	\$0.65
Rosalind Avenue										
Mills Avenue										
Bumby Avenue	\$0.28	\$0.33	\$0.28	\$0.35	\$0.36	\$0.44			\$0.41	\$0.54
Crystal Lake Drive										
Conway Road	\$0.27	\$0.30	\$0.27	\$0.32	\$0.33	\$0.38			\$0.35	\$0.43
Andes Avenue	\$0.28	\$0.31	\$0.28	\$0.32	\$0.33	\$0.38			\$0.36	\$0.42
Semorán Boulevard (SR 436)	\$0.26	\$0.29	\$0.26	\$0.30	\$0.31	\$0.35			\$0.32	\$0.38
Yucatan Drive										
Goldenrod Road	\$0.22	\$0.25	\$0.22	\$0.25	\$0.25	\$0.28			\$0.25	\$0.29
Chickasaw Trail	\$0.20	\$0.19	\$0.19	\$0.18	\$0.22	\$0.20			\$0.21	\$0.20
SR 417 (GreeneWay)	\$0.19	\$0.21	\$0.18	\$0.20	\$0.20	\$0.23			\$0.19	\$0.23
Dean Road	\$0.30	\$0.25	\$0.30	\$0.25	\$0.33	\$0.28			\$0.34	\$0.29
Rouse Road	\$0.22	\$0.25	\$0.22	\$0.25	\$0.24	\$0.27			\$0.24	\$0.28
Alafaya Trail	\$0.20	\$0.23	\$0.20	\$0.23	\$0.21	\$0.24			\$0.21	\$0.25
SR 50 (East Colonial Drive)	\$0.18	\$0.20	\$0.18	\$0.20	\$0.19	\$0.22			\$0.19	\$0.22



Toll Rates Between Interchanges (\$ Toll Rate/Mile) - 2 Axle Vehicles Only
SR 408 (East-West Expressway) - Continued

From	To									
	Interstate 4 (I-4)		Orange Avenue		Rosalind Avenue		Mills Avenue		Bumby Avenue	
	E-PASS	CASH	E-PASS	CASH	E-PASS	CASH	E-PASS	CASH	E-PASS	CASH
Florida's Turnpike	\$0.22	\$0.25	\$0.21	\$0.23	-----	-----	\$0.24	\$0.29	\$0.23	\$0.27
SR 50/Clarke Road	\$0.24	\$0.28	\$0.23	\$0.26	-----	-----	\$0.27	\$0.31	\$0.25	\$0.29
Good Homes Road	\$0.27	\$0.30	\$0.25	\$0.28	-----	-----	\$0.29	\$0.34	\$0.27	\$0.31
Hiwassee Road	\$0.35	\$0.40	\$0.32	\$0.36	-----	-----	\$0.36	\$0.42	\$0.32	\$0.38
Kirkman Road	\$0.25	\$0.28	\$0.22	\$0.25	-----	-----	\$0.29	\$0.34	\$0.25	\$0.30
Pine Hills Road	\$0.29	\$0.32	\$0.25	\$0.28	-----	-----	\$0.32	\$0.37	\$0.28	\$0.33
Old Winter Garden/Mercy-Ortman Drive	\$0.30	\$0.35	\$0.25	\$0.29	-----	-----	\$0.33	\$0.41	\$0.28	\$0.35
John Young Parkway	\$0.49	\$0.57	\$0.37	\$0.43	-----	-----	\$0.45	\$0.55	\$0.36	\$0.44
Tampa Avenue	-----	-----	-----	-----	-----	-----	-----	-----	-----	-----
Orange Blossom Trail	\$1.00	\$1.32	\$0.49	\$0.65	-----	-----	\$0.56	\$0.74	\$0.41	\$0.54
Interstate 4 (I-4)	-----	-----	\$0.00	\$0.00	-----	-----	\$0.39	\$0.52	\$0.26	\$0.34
Orange Avenue	-----	-----	-----	-----	-----	-----	-----	-----	-----	-----
Rosalind Avenue	-----	-----	-----	-----	-----	-----	\$0.98	\$1.29	\$0.42	\$0.56
Mills Avenue	-----	-----	-----	-----	-----	-----	-----	-----	\$0.75	\$0.99
Bumby Avenue	\$0.26	\$0.34	-----	-----	-----	\$0.56	-----	-----	-----	-----
Crystal Lake Drive	-----	-----	-----	-----	-----	-----	-----	-----	-----	-----
Conway Road	\$0.25	\$0.29	-----	-----	-----	\$0.39	\$0.43	\$0.50	-----	-----
Andes Avenue	\$0.27	\$0.30	-----	-----	-----	\$0.37	\$0.41	\$0.45	-----	-----
Semorán Boulevard (SR 436)	\$0.24	\$0.26	-----	-----	-----	\$0.32	\$0.34	\$0.38	-----	-----
Yucatan Drive	-----	-----	-----	-----	-----	-----	-----	-----	-----	-----
Goldenrod Road	\$0.18	\$0.20	-----	-----	-----	\$0.23	\$0.24	\$0.26	-----	-----
Chickasaw Trail	\$0.15	\$0.11	-----	-----	-----	\$0.13	\$0.19	\$0.14	-----	-----
SR 417 (GreeneWay)	\$0.14	\$0.15	-----	-----	-----	\$0.17	\$0.17	\$0.18	-----	-----
Dean Road	\$0.30	\$0.22	-----	-----	-----	\$0.24	\$0.36	\$0.26	-----	-----
Rouse Road	\$0.19	\$0.22	-----	-----	-----	\$0.24	\$0.22	\$0.25	-----	-----
Alafaya Trail	\$0.17	\$0.20	-----	-----	-----	\$0.21	\$0.20	\$0.22	-----	-----
SR 50 (East Colonial Drive)	\$0.15	\$0.17	-----	-----	-----	\$0.18	\$0.17	\$0.19	-----	-----



Toll Rates Between Interchanges (\$ Toll Rate/Mile) - 2 Axle Vehicles Only
SR 408 (East-West Expressway) - Continued

From	To											
	Crystal Lake Drive		Conway Road		Andes Avenue		Semoran Blvd.		Yucatan Drive		Goldenrod Road	
	E-PASS	CASH	E-PASS	CASH	E-PASS	CASH	E-PASS	CASH	E-PASS	CASH	E-PASS	CASH
Florida's Turnpike	---	---	\$0.23	\$0.26	\$0.30	\$0.34	---	---	---	---	\$0.33	\$0.38
SR 50/Clarke Road	---	---	\$0.25	\$0.28	\$0.32	\$0.36	---	---	---	---	\$0.35	\$0.40
Good Homes Road	---	---	\$0.26	\$0.30	\$0.34	\$0.39	---	---	---	---	\$0.37	\$0.42
Hiwassee Road	---	---	\$0.31	\$0.36	\$0.40	\$0.46	---	---	---	---	\$0.43	\$0.48
Kirkman Road	---	---	\$0.25	\$0.28	\$0.36	\$0.40	---	---	---	---	\$0.39	\$0.44
Pine Hills Road	---	---	\$0.27	\$0.30	\$0.38	\$0.43	---	---	---	---	\$0.42	\$0.47
Old Winter Garden/Mercy-Ortman Drive	---	---	\$0.27	\$0.32	\$0.41	\$0.46	---	---	---	---	\$0.44	\$0.50
John Young Parkway	---	---	\$0.33	\$0.38	\$0.48	\$0.55	---	---	---	---	\$0.50	\$0.56
Tampa Avenue	---	---	---	---	---	---	---	---	---	---	---	---
Orange Blossom Trail	---	---	\$0.35	\$0.43	\$0.54	\$0.63	---	---	---	---	\$0.54	\$0.62
Interstate 4 (I-4)	---	---	\$0.25	\$0.29	\$0.47	\$0.53	---	---	---	---	\$0.50	\$0.56
Orange Avenue	---	---	---	---	---	---	---	---	---	---	---	---
Rosalind Avenue	---	---	\$0.33	\$0.39	\$0.60	\$0.67	---	---	---	---	\$0.58	\$0.65
Mills Avenue	---	---	\$0.43	\$0.50	\$0.72	\$0.82	---	---	---	---	\$0.65	\$0.73
Bumby Avenue	---	---	---	---	---	---	---	---	---	---	---	---
Crystal Lake Drive	---	---	\$1.37	\$1.59	\$0.82	\$0.91	---	---	---	---	\$0.66	\$0.73
Conway Road	\$1.37	\$1.59	---	---	---	---	---	---	---	---	---	---
Andes Avenue	\$0.82	\$0.91	---	---	---	---	---	---	---	---	---	---
Semoran Boulevard (SR 436)	\$0.59	\$0.66	---	---	---	---	---	---	---	---	---	---
Yucatan Drive	---	---	---	---	---	---	---	---	---	---	---	---
Goldenrod Road	\$0.33	\$0.37	---	---	---	---	---	---	---	---	\$0.69	\$0.81
Chickasaw Trail	\$0.25	\$0.19	---	---	---	---	---	---	---	---	---	---
SR 417 (GreeneWay)	\$0.21	\$0.23	---	---	---	---	---	---	---	---	\$0.00	\$0.00
Dean Road	\$0.44	\$0.32	---	---	---	---	---	---	---	---	\$0.87	\$0.63
Rouse Road	\$0.27	\$0.30	---	---	---	---	---	---	---	---	\$0.42	\$0.49
Alafaya Trail	\$0.23	\$0.26	---	---	---	---	---	---	---	---	\$0.33	\$0.38
SR 50 (East Colonial Drive)	\$0.19	\$0.22	---	---	---	---	---	---	---	---	\$0.25	\$0.29



Toll Rates Between Interchanges (\$ Toll Rate/Mile) - 2 Axle Vehicles Only
SR 408 (East-West Expressway) - Continued

From	To											
	Chickasaw Trail		SR 417 (GreeneWay)		Dean Road		Rouse Road		Alafaya Trail		SR 50 (Colonial Dr.)	
	E-PASS	CASH	E-PASS	CASH	E-PASS	CASH	E-PASS	CASH	E-PASS	CASH	E-PASS	CASH
Florida's Turnpike	\$0.32	\$0.36	\$0.30	\$0.33	\$0.37	\$0.36	\$0.31	\$0.35	\$0.29	\$0.33	\$0.27	\$0.30
SR 50/Clarke Road	\$0.34	\$0.38	\$0.31	\$0.35	\$0.39	\$0.38	\$0.32	\$0.37	\$0.30	\$0.34	\$0.28	\$0.32
Good Homes Road	\$0.36	\$0.40	\$0.33	\$0.37	\$0.41	\$0.39	\$0.34	\$0.38	\$0.31	\$0.36	\$0.29	\$0.33
Hiwassee Road	\$0.41	\$0.46	\$0.37	\$0.41	\$0.45	\$0.44	\$0.37	\$0.42	\$0.35	\$0.39	\$0.32	\$0.36
Kirkman Road	\$0.38	\$0.42	\$0.33	\$0.37	\$0.43	\$0.41	\$0.34	\$0.39	\$0.32	\$0.36	\$0.29	\$0.32
Pine Hills Road	\$0.40	\$0.44	\$0.35	\$0.39	\$0.45	\$0.42	\$0.36	\$0.40	\$0.33	\$0.37	\$0.30	\$0.34
Old Winter Garden/Mercy-Ortman Drive	\$0.41	\$0.47	\$0.36	\$0.41	\$0.47	\$0.44	\$0.37	\$0.42	\$0.34	\$0.38	\$0.30	\$0.34
John Young Parkway	\$0.46	\$0.52	\$0.40	\$0.45	\$0.51	\$0.49	\$0.40	\$0.46	\$0.36	\$0.41	\$0.32	\$0.37
Tampa Avenue	-----	-----	-----	-----	-----	-----	-----	-----	-----	-----	-----	-----
Orange Blossom Trail	\$0.50	\$0.57	\$0.42	\$0.48	\$0.55	\$0.52	\$0.42	\$0.48	\$0.38	\$0.43	\$0.33	\$0.38
Interstate 4 (I-4)	\$0.46	\$0.51	\$0.38	\$0.43	\$0.52	\$0.47	\$0.39	\$0.44	\$0.35	\$0.39	\$0.30	\$0.34
Orange Avenue	-----	-----	-----	-----	-----	-----	-----	-----	-----	-----	-----	-----
Rosalind Avenue	\$0.52	\$0.59	\$0.42	\$0.48	\$0.57	\$0.52	\$0.42	\$0.48	\$0.37	\$0.42	\$0.32	\$0.36
Mills Avenue	\$0.58	\$0.65	\$0.46	\$0.52	\$0.62	\$0.56	\$0.45	\$0.51	\$0.40	\$0.45	\$0.34	\$0.38
Bumby Avenue	-----	-----	-----	-----	-----	-----	-----	-----	-----	-----	-----	-----
Crystal Lake Drive	\$0.57	\$0.63	\$0.42	\$0.46	\$0.62	\$0.52	\$0.42	\$0.47	\$0.36	\$0.40	\$0.30	\$0.34
Conway Road	-----	-----	-----	-----	-----	-----	-----	-----	-----	-----	-----	-----
Andes Avenue	-----	-----	-----	-----	-----	-----	-----	-----	-----	-----	-----	-----
Semorran Boulevard (SR 436)	-----	-----	-----	-----	-----	-----	-----	-----	-----	-----	-----	-----
Yucatan Drive	\$0.48	\$0.55	\$0.27	\$0.31	\$0.60	\$0.43	\$0.32	\$0.38	\$0.26	\$0.31	\$0.21	\$0.24
Goldenrod Road	-----	-----	\$0.00	\$0.00	\$0.56	\$0.27	\$0.21	\$0.25	\$0.16	\$0.19	\$0.12	\$0.14
Chickasaw Trail	-----	-----	-----	-----	-----	-----	-----	-----	-----	-----	-----	-----
SR 417 (GreeneWay)	-----	-----	-----	-----	\$1.90	\$0.91	\$0.41	\$0.48	\$0.26	\$0.30	\$0.17	\$0.20
Dean Road	-----	-----	\$2.94	\$2.12	-----	-----	\$0.68	\$0.79	\$0.35	\$0.40	\$0.21	\$0.24
Rouse Road	-----	-----	\$0.82	\$0.95	\$1.35	\$1.57	-----	-----	\$0.47	\$0.62	\$0.20	\$0.26
Alafaya Trail	-----	-----	\$0.52	\$0.61	\$0.69	\$0.81	\$0.47	\$0.62	-----	-----	-----	-----
SR 50 (East Colonial Drive)	-----	-----	\$0.34	\$0.40	\$0.41	\$0.48	\$0.00	\$0.00	-----	-----	-----	-----



Toll Rates Between Interchanges (\$ Toll Rate/Mile) - 2 Axle Vehicles Only
SR 408 (East-West Expressway) - Continued

From	To									
	Boggy Creek Rd.		Tradeport/Conway		Semoran Blvd/Airport		Goldenrod Road		Narcoossee Road	
	E-PASS	CASH	E-PASS	CASH	E-PASS	CASH	E-PASS	CASH	E-PASS	CASH
US 441/Florida's Turnpike	\$0.32	\$0.35	\$0.24	\$0.21	\$0.18	\$0.16	\$0.15	\$0.13	\$0.13	\$0.11
Boggy Creek Road	-----	-----	\$1.05	\$1.16	\$0.44	\$0.49	\$0.29	\$0.32	\$0.21	\$0.24
Tradeport Dr/Conway Road	\$1.05	\$1.16	-----	-----	\$0.75	\$0.83	\$0.39	\$0.44	\$0.27	\$0.30
Semoran Boulevard/Airport	\$0.44	\$0.49	\$0.75	\$0.83	-----	-----	\$0.00	\$0.00	\$0.00	\$0.00
Goldenrod Road	\$0.29	\$0.32	\$0.39	\$0.44	\$0.00	\$0.00	-----	-----	\$0.00	\$0.00
Narcoossee Road	\$0.21	\$0.24	\$0.27	\$0.30	\$0.00	\$0.00	\$0.00	\$0.00	-----	-----
SR 417 (GreeneWay)	\$0.15	\$0.17	\$0.18	\$0.20	\$0.00	\$0.00	\$0.00	\$0.00	\$0.00	\$0.00
Innovation Way	\$0.18	\$0.22	\$0.19	\$0.24	\$0.10	\$0.14	\$0.12	\$0.16	\$0.14	\$0.20
Dallas Boulevard	\$0.16	\$0.21	\$0.18	\$0.22	\$0.11	\$0.15	\$0.12	\$0.17	\$0.14	\$0.19
SR 520	\$0.11	\$0.14	\$0.12	\$0.15	\$0.07	\$0.10	\$0.08	\$0.11	\$0.08	\$0.12
Brevard County Line	\$0.09	\$0.12	\$0.10	\$0.12	\$0.06	\$0.08	\$0.06	\$0.08	\$0.06	\$0.09

From	To									
	SR 417 (GreeneWay)		Innovation Way		Dallas Boulevard		SR 520		Brevard County Line	
	E-PASS	CASH	E-PASS	CASH	E-PASS	CASH	E-PASS	CASH	E-PASS	CASH
US 441/Florida's Turnpike	\$0.10	\$0.09	\$0.13	\$0.15	\$0.13	\$0.16	\$0.10	\$0.11	\$0.08	\$0.10
Boggy Creek Road	\$0.15	\$0.17	\$0.18	\$0.22	\$0.16	\$0.21	\$0.14	\$0.18	\$0.11	\$0.14
Tradeport Dr/Conway Road	\$0.18	\$0.20	\$0.19	\$0.24	\$0.18	\$0.22	\$0.12	\$0.15	\$0.10	\$0.12
Semoran Boulevard/Airport	\$0.00	\$0.00	\$0.10	\$0.14	\$0.11	\$0.15	\$0.07	\$0.10	\$0.06	\$0.08
Goldenrod Road	\$0.00	\$0.00	\$0.12	\$0.16	\$0.12	\$0.17	\$0.08	\$0.11	\$0.06	\$0.08
Narcoossee Road	\$0.00	\$0.00	\$0.14	\$0.20	\$0.14	\$0.19	\$0.08	\$0.12	\$0.06	\$0.09
SR 417 (GreeneWay)	-----	-----	\$0.22	\$0.30	\$0.17	\$0.24	\$0.09	\$0.13	\$0.07	\$0.10
Innovation Way	\$0.22	\$0.30	-----	-----	\$0.13	\$0.19	\$0.05	\$0.07	\$0.03	\$0.05
Dallas Boulevard	\$0.17	\$0.24	\$0.13	\$0.19	-----	-----	-----	-----	-----	-----
SR 520	\$0.09	\$0.13	\$0.05	\$0.07	-----	-----	-----	-----	\$0.05	\$0.10
Brevard County Line	\$0.07	\$0.10	\$0.03	\$0.05	-----	-----	\$0.05	\$0.10	-----	-----



Toll Rates Between Interchanges (\$ Toll Rate/Mile) - 2 Axle Vehicles Only
SR 528 (Beachline Expressway)

From	To											
	International Drive		John Young Parkway		Orange Blossom Trail		Florida's Turnpike		Landstar Boulevard			
	E-PASS	CASH	E-PASS	CASH	E-PASS	CASH	E-PASS	CASH	E-PASS	CASH		
International Drive	-----	-----	\$0.34	\$0.41	\$0.26	\$0.31	-----	-----	\$0.24	\$0.28		
John Young Parkway	\$0.34	\$0.41	-----	-----	\$0.63	\$0.73	-----	-----	\$0.37	\$0.40		
Orange Blossom Trail	\$0.26	\$0.31	\$0.63	\$0.73	-----	-----	\$0.89	\$1.03	\$0.58	\$0.64		
Florida's Turnpike	-----	-----	-----	-----	-----	-----	-----	-----	\$0.36	\$0.36		
Landstar Boulevard	\$0.24	\$0.28	\$0.37	\$0.40	\$0.46	\$0.53	\$0.36	\$0.36	-----	-----		
South Access Road (Int'l Airport)	\$0.25	\$0.31	\$0.32	\$0.38	\$0.34	\$0.43	\$0.29	\$0.36	\$0.41	\$0.50		
Boggy Creek Road	\$0.25	\$0.31	\$0.32	\$0.38	\$0.34	\$0.43	\$0.29	\$0.36	\$0.41	\$0.50		
Lake Nona Boulevard	\$0.21	\$0.26	\$0.25	\$0.29	\$0.25	\$0.31	\$0.20	\$0.25	\$0.25	\$0.31		
Narcoossee Road	\$0.18	\$0.22	\$0.19	\$0.23	\$0.19	\$0.24	\$0.15	\$0.18	\$0.18	\$0.21		
Moss Park Road	\$0.16	\$0.20	\$0.17	\$0.21	\$0.17	\$0.21	\$0.13	\$0.16	\$0.15	\$0.18		
Dowden Road	\$0.15	\$0.19	\$0.16	\$0.19	\$0.16	\$0.19	\$0.12	\$0.15	\$0.14	\$0.17		
SR 528 (Beachline Expressway)	\$0.14	\$0.17	\$0.14	\$0.17	\$0.14	\$0.17	\$0.11	\$0.13	\$0.12	\$0.14		
Lee Vista Boulevard	\$0.16	\$0.19	\$0.16	\$0.20	\$0.16	\$0.20	\$0.13	\$0.16	\$0.14	\$0.18		
Curry Ford Road	\$0.15	\$0.18	\$0.16	\$0.19	\$0.15	\$0.19	\$0.13	\$0.15	\$0.14	\$0.17		
SR 408 (East-West Expressway)	\$0.14	\$0.17	\$0.14	\$0.16	\$0.13	\$0.16	\$0.11	\$0.13	\$0.12	\$0.14		
SR 50 (Colonial Drive)	\$0.15	\$0.18	\$0.15	\$0.18	\$0.15	\$0.18	\$0.13	\$0.16	\$0.14	\$0.17		
University Boulevard	\$0.15	\$0.18	\$0.15	\$0.18	\$0.15	\$0.18	\$0.13	\$0.15	\$0.14	\$0.16		
Aloma Avenue	\$0.15	\$0.18	\$0.15	\$0.18	\$0.15	\$0.18	\$0.13	\$0.15	\$0.14	\$0.16		



**Toll Rates Between Interchanges (\$ Toll Rate/Mile) - 2 Axle Vehicles Only
SR 417 (Central Florida GreeneWay)**

From	To											
	South Access (Airport)		Boggy Creek Road		Lake Nona Boulevard		Narcoossee Road		Moss Park Road			
	E-PASS	CASH	E-PASS	CASH	E-PASS	CASH	E-PASS	CASH	E-PASS	CASH		
International Drive	\$0.26	\$0.32	\$0.25	\$0.31	\$0.21	\$0.26	\$0.18	\$0.22	\$0.16	\$0.20		
John Young Parkway	\$0.32	\$0.38	\$0.32	\$0.38	\$0.25	\$0.29	\$0.19	\$0.23	\$0.17	\$0.21		
Orange Blossom Trail	\$0.39	\$0.47	\$0.39	\$0.47	\$0.29	\$0.35	\$0.22	\$0.26	\$0.19	\$0.23		
Florida's Turnpike	\$0.29	\$0.36	\$0.29	\$0.36	\$0.20	\$0.25	\$0.15	\$0.18	\$0.13	\$0.16		
Landstar Boulevard	\$0.41	\$0.50	\$0.41	\$0.50	\$0.25	\$0.31	\$0.18	\$0.21	\$0.15	\$0.18		
South Access Road (Int'l Airport)	-----	-----	-----	-----	\$0.54	\$0.60	\$0.24	\$0.27	\$0.19	\$0.20		
Boggy Creek Road	-----	-----	-----	-----	\$0.54	\$0.60	\$0.24	\$0.27	\$0.19	\$0.20		
Lake Nona Boulevard	\$0.54	\$0.60	\$0.54	\$0.60	-----	-----	\$0.34	\$0.39	\$0.21	\$0.25		
Narcoossee Road	\$0.24	\$0.27	\$0.24	\$0.27	\$0.34	\$0.39	-----	-----	\$0.59	\$0.68		
Moss Park Road	\$0.19	\$0.20	\$0.19	\$0.20	\$0.21	\$0.25	\$0.59	\$0.68	-----	-----		
Dowden Road	\$0.16	\$0.18	\$0.16	\$0.18	\$0.17	\$0.20	\$0.36	\$0.42	\$0.62	\$0.81		
SR 528 (Beachline Expressway)	\$0.13	\$0.14	\$0.13	\$0.14	\$0.13	\$0.15	\$0.21	\$0.25	\$0.22	\$0.29		
Lee Vista Boulevard	\$0.16	\$0.19	\$0.16	\$0.19	\$0.17	\$0.21	\$0.24	\$0.30	\$0.26	\$0.34		
Curry Ford Road	\$0.15	\$0.17	\$0.15	\$0.17	\$0.16	\$0.19	\$0.21	\$0.24	\$0.21	\$0.26		
SR 408 (East-West Expressway)	\$0.13	\$0.14	\$0.13	\$0.14	\$0.13	\$0.15	\$0.16	\$0.18	\$0.15	\$0.18		
SR 50 (Colonial Drive)	\$0.15	\$0.17	\$0.15	\$0.17	\$0.15	\$0.18	\$0.18	\$0.22	\$0.18	\$0.22		
University Boulevard	\$0.15	\$0.17	\$0.15	\$0.17	\$0.15	\$0.17	\$0.17	\$0.20	\$0.17	\$0.20		
Aloma Avenue	\$0.15	\$0.17	\$0.15	\$0.17	\$0.15	\$0.17	\$0.17	\$0.20	\$0.17	\$0.20		



**Toll Rates Between Interchanges (\$ Toll Rate/Mile) - 2 Axle Vehicles Only
SR 417 (Central Florida GreeneWay) - Continued**

From	To									
	Dowden Road		SR 528 (Beachline)		Lee Vista Boulevard		Curry Ford Road			
	E-PASS	CASH	E-PASS	CASH	E-PASS	CASH	E-PASS	CASH	E-PASS	CASH
International Drive	\$0.15	\$0.19	\$0.14	\$0.17	\$0.16	\$0.19	\$0.15	\$0.18		
John Young Parkway	\$0.16	\$0.19	\$0.14	\$0.17	\$0.16	\$0.20	\$0.16	\$0.19		
Orange Blossom Trail	\$0.18	\$0.21	\$0.16	\$0.19	\$0.17	\$0.21	\$0.17	\$0.20		
Florida's Turnpike	\$0.12	\$0.15	\$0.11	\$0.13	\$0.13	\$0.16	\$0.13	\$0.15		
Landstar Boulevard	\$0.14	\$0.17	\$0.12	\$0.14	\$0.14	\$0.18	\$0.14	\$0.17		
South Access Road (Int'l Airport)	\$0.16	\$0.18	\$0.13	\$0.14	\$0.16	\$0.19	\$0.15	\$0.17		
Boggy Creek Road	\$0.16	\$0.18	\$0.13	\$0.14	\$0.16	\$0.19	\$0.15	\$0.17		
Lake Nona Boulevard	\$0.17	\$0.20	\$0.13	\$0.15	\$0.17	\$0.21	\$0.16	\$0.19		
Narcoossee Road	\$0.36	\$0.42	\$0.21	\$0.25	\$0.24	\$0.30	\$0.21	\$0.24		
Moss Park Road	\$0.62	\$0.81	\$0.22	\$0.29	\$0.26	\$0.34	\$0.21	\$0.26		
Dowden Road	-----	-----	\$0.35	\$0.46	\$0.32	\$0.42	\$0.25	\$0.30		
SR 528 (Beachline Expressway)	\$0.35	\$0.46	-----	-----	\$0.30	\$0.39	\$0.20	\$0.24		
Lee Vista Boulevard	\$0.32	\$0.42	\$0.30	\$0.39	-----	-----	\$0.37	\$0.43		
Curry Ford Road	\$0.25	\$0.30	\$0.20	\$0.24	\$0.37	\$0.43	-----	-----		
SR 408 (East-West Expressway)	\$0.17	\$0.20	\$0.12	\$0.14	\$0.17	\$0.20	\$0.21	\$0.27		
SR 50 (Colonial Drive)	\$0.20	\$0.24	\$0.17	\$0.20	\$0.21	\$0.26	\$0.26	\$0.34		
University Boulevard	\$0.18	\$0.22	\$0.16	\$0.18	\$0.19	\$0.22	\$0.21	\$0.26		
Aloma Avenue	\$0.18	\$0.21	\$0.16	\$0.18	\$0.19	\$0.21	\$0.20	\$0.24		



**Toll Rates Between Interchanges (\$ Toll Rate/Mile) - 2 Axle Vehicles Only
SR 417 (Central Florida GreeneWay) - Continued**

From	To									
	SR 408 (East West)		SR 50 (Colonial Dr.)		University Boulevard		Aloma Avenue			
	E-PASS	CASH	E-PASS	CASH	E-PASS	CASH	E-PASS	CASH		
International Drive	\$0.14	\$0.17	\$0.15	\$0.18	\$0.15	\$0.18	\$0.13	\$0.16		
John Young Parkway	\$0.14	\$0.16	\$0.15	\$0.18	\$0.15	\$0.18	\$0.13	\$0.16		
Orange Blossom Trail	\$0.15	\$0.17	\$0.16	\$0.19	\$0.16	\$0.19	\$0.14	\$0.17		
Florida's Turnpike	\$0.11	\$0.13	\$0.13	\$0.16	\$0.13	\$0.15	\$0.11	\$0.13		
Landstar Boulevard	\$0.12	\$0.14	\$0.14	\$0.17	\$0.14	\$0.16	\$0.12	\$0.14		
South Access Road (Int'l Airport)	\$0.13	\$0.14	\$0.15	\$0.17	\$0.15	\$0.17	\$0.12	\$0.14		
Boggy Creek Road	\$0.13	\$0.14	\$0.15	\$0.17	\$0.15	\$0.17	\$0.12	\$0.14		
Lake Nona Boulevard	\$0.13	\$0.15	\$0.15	\$0.18	\$0.15	\$0.17	\$0.12	\$0.14		
Narcoossee Road	\$0.16	\$0.18	\$0.18	\$0.22	\$0.17	\$0.20	\$0.14	\$0.17		
Moss Park Road	\$0.15	\$0.18	\$0.18	\$0.22	\$0.17	\$0.20	\$0.13	\$0.17		
Dowden Road	\$0.17	\$0.20	\$0.20	\$0.24	\$0.18	\$0.22	\$0.14	\$0.18		
SR 528 (Beachline Expressway)	\$0.12	\$0.14	\$0.17	\$0.20	\$0.16	\$0.18	\$0.11	\$0.14		
Lee Vista Boulevard	\$0.17	\$0.20	\$0.21	\$0.26	\$0.19	\$0.22	\$0.13	\$0.16		
Curry Ford Road	\$0.32	\$0.37	\$0.32	\$0.40	\$0.26	\$0.30	\$0.17	\$0.21		
SR 408 (East-West Expressway)	-----	-----	\$0.34	\$0.44	\$0.22	\$0.25	\$0.10	\$0.13		
SR 50 (Colonial Drive)	\$0.50	\$0.74	-----	-----	\$0.38	\$0.44	\$0.15	\$0.19		
University Boulevard	\$0.29	\$0.38	\$0.50	\$0.66	-----	-----	\$0.35	\$0.46		
Aloma Avenue	\$0.25	\$0.31	\$0.36	\$0.45	\$0.35	\$0.46	-----	-----		



**Toll Rates Between Interchanges (\$ Toll Rate/Mile) - 2 Axle Vehicles Only
SR 417 (Central Florida GreeneWay) - Continued**

From	To											
	Seidel Road		Schofield Road		New Independence Pkwy		CR 535		Florida's Turnpike			
	E-PASS	CASH	E-PASS	CASH	E-PASS	CASH	E-PASS	CASH	E-PASS	CASH		
Seidel Road	-----	-----	-----	-----	-----	-----	-----	-----	-----	-----	-----	-----
Schofield Road	-----	-----	-----	-----	\$0.44	\$0.51	\$0.23	\$0.22	\$0.15	\$0.16	-----	-----
New Independence Parkway	-----	-----	\$0.44	\$0.51	-----	-----	\$0.33	\$0.32	\$0.19	\$0.20	\$0.15	\$0.20
CR 535 (Old Winter Garden)	-----	-----	\$0.23	\$0.28	\$0.33	\$0.40	-----	-----	\$0.19	\$0.25	\$0.19	\$0.25
Florida's Turnpike (SR 91)	-----	-----	\$0.15	\$0.19	\$0.20	\$0.24	\$0.19	\$0.25	-----	-----	-----	-----
SR 50 (West Colonial Drive)	-----	-----	\$0.15	\$0.18	\$0.19	\$0.23	\$0.17	\$0.23	-----	-----	-----	-----
Plant Street/Franklin Street/SR 438	-----	-----	\$0.16	\$0.20	\$0.19	\$0.25	\$0.18	\$0.26	\$0.17	\$0.28	-----	-----
West Road	-----	-----	\$0.17	\$0.20	\$0.20	\$0.24	\$0.20	\$0.24	\$0.20	\$0.23	\$0.20	\$0.23
CR 437A (Ocoee Apopka Road)	-----	-----	\$0.18	\$0.22	\$0.20	\$0.25	\$0.21	\$0.26	\$0.21	\$0.26	\$0.21	\$0.26
SR 414 (Apopka Expressway)	-----	-----	\$0.16	\$0.20	\$0.18	\$0.23	\$0.18	\$0.23	\$0.18	\$0.23	\$0.18	\$0.21
SR 429 Connector Road	-----	-----	\$0.14	\$0.17	\$0.15	\$0.19	\$0.14	\$0.17	\$0.14	\$0.17	\$0.12	\$0.15
Kelly Park Road	-----	-----	\$0.15	\$0.20	\$0.16	\$0.21	\$0.15	\$0.21	\$0.15	\$0.21	\$0.14	\$0.20
SR 453	-----	-----	\$0.14	\$0.19	\$0.15	\$0.20	\$0.14	\$0.20	\$0.14	\$0.20	\$0.13	\$0.19
SR 46	-----	-----	\$0.15	\$0.22	\$0.17	\$0.23	\$0.16	\$0.24	\$0.16	\$0.24	\$0.16	\$0.23

Notes:

1. For cash traffic passing through Ponkan and Mount Plymouth Mainline Gantry it is assumed Pay-By-Plate is used



**Toll Rates Between Interchanges (\$ Toll Rate/Mile) - 2 Axle Vehicles Only
SR 429 (Western Beltway)**

From	To												
	SR 50 (Colonial Dr.)		Plant/Franklin St.		West Road		CR 437A		SR 414 (Apopka Expwy)				
	E-PASS	CASH	E-PASS	CASH	E-PASS	CASH	E-PASS	CASH	E-PASS	CASH			
Seidel Road	---	---	---	---	---	---	---	---	---	---	---	---	---
Schofield Road	\$0.15	\$0.16	\$0.16	\$0.18	\$0.17	\$0.18	\$0.18	\$0.19	\$0.16	\$0.17	\$0.17	\$0.16	\$0.17
New Independence Parkway	\$0.18	\$0.20	\$0.18	\$0.22	\$0.19	\$0.22	\$0.22	\$0.21	\$0.20	\$0.21	\$0.19	\$0.18	\$0.19
CR 535 (Old Winter Garden)	\$0.17	\$0.23	\$0.18	\$0.26	\$0.20	\$0.24	\$0.20	\$0.23	\$0.20	\$0.23	\$0.20	\$0.18	\$0.20
Florida's Turnpike (SR 91)	---	---	\$0.17	\$0.28	\$0.20	\$0.23	\$0.21	\$0.22	\$0.17	\$0.18	\$0.17	\$0.17	\$0.18
SR 50 (West Colonial Drive)	---	---	\$0.21	\$0.35	\$0.22	\$0.25	\$0.22	\$0.23	\$0.18	\$0.19	\$0.19	\$0.18	\$0.19
Plant Street/Franklin Street/SR 438	\$0.21	\$0.35	---	---	\$0.34	\$0.40	\$0.40	\$0.30	\$0.22	\$0.23	\$0.23	\$0.22	\$0.23
West Road	\$0.22	\$0.25	\$0.34	\$0.40	---	---	---	\$0.30	\$0.15	\$0.19	\$0.19	\$0.15	\$0.19
CR 437A (Ocoee Apopka Road)	\$0.22	\$0.27	\$0.28	\$0.35	\$0.57	\$0.70	\$0.70	---	\$0.42	\$0.42	---	\$0.42	\$0.55
SR 414 (Apopka Expressway)	\$0.18	\$0.22	\$0.22	\$0.27	\$0.37	\$0.45	\$0.45	\$0.55	---	---	---	---	---
SR 429 Connector Road	\$0.13	\$0.16	\$0.15	\$0.18	\$0.20	\$0.24	\$0.24	\$0.16	\$0.00	\$0.00	\$0.00	\$0.00	\$0.00
Kelly Park Road	\$0.15	\$0.21	\$0.16	\$0.23	\$0.20	\$0.28	\$0.16	\$0.24	\$0.18	\$0.24	\$0.18	\$0.18	\$0.29
SR 453	\$0.14	\$0.19	\$0.15	\$0.21	\$0.18	\$0.25	\$0.14	\$0.21	\$0.16	\$0.21	\$0.16	\$0.16	\$0.24
SR 46	\$0.16	\$0.24	\$0.17	\$0.26	\$0.20	\$0.30	\$0.17	\$0.28	\$0.19	\$0.28	\$0.19	\$0.19	\$0.31

Notes:

1. For cash traffic passing through Ponkan and Mount Plymouth Mainline Gantry it is assumed Pay-By-Plate is used



Toll Rates Between Interchanges (\$ Toll Rate/Mile) - 2 Axle Vehicles Only
SR 429 (Western Beltway)

From	To									
	SR 429 Connector Rd.		Kelly Park Road		SR 429/453 System Int		SR 46			
	E-PASS	CASH	E-PASS	CASH	E-PASS	CASH	E-PASS	CASH		
Seidel Road	-----	-----	-----	-----	-----	-----	-----	-----	-----	-----
Schofield Road	\$0.14	\$0.14	\$0.15	\$0.15	\$0.17	\$0.18	\$0.18	\$0.19	\$0.18	\$0.19
New Independence Parkway	\$0.15	\$0.16	\$0.16	\$0.17	\$0.18	\$0.19	\$0.20	\$0.20	\$0.20	\$0.20
CR 535 (Old Winter Garden)	\$0.14	\$0.15	\$0.15	\$0.16	\$0.18	\$0.19	\$0.20	\$0.20	\$0.20	\$0.21
Florida's Turnpike (SR 91)	\$0.12	\$0.13	\$0.14	\$0.15	\$0.18	\$0.18	\$0.20	\$0.20	\$0.20	\$0.20
SR 50 (West Colonial Drive)	\$0.13	\$0.13	\$0.15	\$0.15	\$0.18	\$0.19	\$0.20	\$0.20	\$0.20	\$0.21
Plant Street/Franklin Street/SR 438	\$0.14	\$0.15	\$0.16	\$0.17	\$0.20	\$0.21	\$0.22	\$0.22	\$0.22	\$0.22
West Road	\$0.08	\$0.10	\$0.12	\$0.14	\$0.17	\$0.19	\$0.20	\$0.21	\$0.21	\$0.21
CR 437A (Ocoee Apopka Road)	\$0.12	\$0.16	\$0.16	\$0.18	\$0.22	\$0.23	\$0.24	\$0.25	\$0.25	\$0.25
SR 414 (Apopka Expressway)	\$0.00	\$0.00	\$0.11	\$0.11	\$0.18	\$0.18	\$0.22	\$0.22	\$0.22	\$0.22
SR 429 Connector Road	-----	-----	\$0.20	\$0.20	\$0.30	\$0.30	\$0.31	\$0.31	\$0.31	\$0.31
Kelly Park Road	\$0.34	\$0.52	-----	-----	-----	-----	-----	-----	-----	-----
SR 453	\$0.26	\$0.40	\$0.62	\$1.06	\$0.62	\$0.62	\$0.44	\$0.44	\$0.44	\$0.44
SR 46	\$0.27	\$0.45	\$0.21	\$0.36	\$0.32	\$0.56	\$0.32	\$0.32	\$0.32	\$0.56

Notes:

1. For cash traffic passing through Ponkan and Mount Plymouth Mainline Gantry it is assumed Pay-By-Plate is used



Toll Rates Between Interchanges (\$ Toll Rate/Mile) - 2 Axle Vehicles Only
SR 429 (Wekiva Parkway)

From	To							
	SR 429 Connector Rd.		SR 451		Marden Road		Keene Road	
	E-PASS	CASH	E-PASS	CASH	E-PASS	CASH	E-PASS	CASH
SR 429 Connector Road	-----	-----	-----	-----	-----	-----	-----	-----
SR 451 (Western Beltway)	-----	-----	-----	-----	-----	-----	-----	-----
Marden Road	-----	-----	-----	-----	-----	-----	-----	-----
Keene Road	-----	-----	-----	-----	-----	-----	-----	-----
Hiawassee Road (CR 435)	\$0.14	\$0.16	\$0.31	\$0.34	\$0.31	\$0.34	\$0.15	\$0.20
OBT - US 441 (East)	\$0.12	\$0.13	\$0.22	\$0.24	\$0.22	\$0.24	\$0.11	\$0.15
Bear Lake Road/Rose Avenue	\$0.11	\$0.12	\$0.19	\$0.21	\$0.19	\$0.21	\$0.10	\$0.13

From	To							
	Hiawassee Road		OBT - US 441 (East)		Bear Lake/Rose Ave.			
	E-PASS	CASH	E-PASS	CASH	E-PASS	CASH	E-PASS	CASH
SR 429 Connector Road	\$0.14	\$0.16	\$0.12	\$0.13	\$0.11	\$0.12	-----	-----
SR 451 (Western Beltway)	\$0.31	\$0.34	\$0.22	\$0.24	\$0.19	\$0.21	-----	-----
Marden Road	\$0.33	\$0.37	\$0.23	\$0.26	\$0.20	\$0.23	-----	-----
Keene Road	\$0.44	\$0.58	\$0.21	\$0.27	\$0.17	\$0.22	-----	-----
Hiawassee Road (CR 435)	-----	-----	\$0.21	\$0.34	\$0.14	\$0.23	-----	-----
OBT - US 441 (East)	\$0.21	\$0.34	-----	-----	\$0.00	\$0.00	-----	-----
Bear Lake Road/Rose Avenue	\$0.14	\$0.23	\$0.00	\$0.00	-----	-----	-----	-----



Toll Rates Between Interchanges (\$ Toll Rate/Mile) - 2 Axle Vehicles Only
SR 414 (Apopka Expressway)

From	To			
	SR 429/453 System Int		SR 46	
	E-PASS	CASH	E-PASS	CASH
SR 429/453 System Interchange SR 46	\$0.33	\$0.63	\$0.33	\$0.63



Toll Rates Between Interchanges (\$ Toll Rate/Mile) - 2 Axle Vehicles Only
SR 453