

CFX Traffic Data and Statistics Manual 2017



Table of Contents



2017 Traffic Data and Statistics Manual
CENTRAL FLORIDA EXPRESSWAY AUTHORITY

TABLE OF CONTENTS

Executive Summary	i
--------------------------------	----------

SECTION I - SYSTEM MAPS

Central Florida Expressway System	1
Toll Plaza Location Map	2

SECTION II - TRAFFIC COUNTS

Traffic Counts Introduction	3
2017 AAWT Segment & Mainline Plaza Volumes	4
SR 408 (East-West Expressway) Mainline Volume Summary	6
SR 408 (East-West Expressway) Interchange-Ramp Volume Summary	7
SR 528 (Beachline Expressway) Mainline Volume Summary	13
SR 528 -(Beachline Expressway) Interchange-Ramp Volume Summary	14
SR 417 (Central Florida GreeneWay) Mainline Volume Summary	18
SR 417 (Central Florida GreeneWay) Interchange-Ramp Volume Summary	19
SR 429 (Western Beltway and Wekiva Parkway) Mainline Volume Summary	24
SR 429 (Western Beltway and Wekiva Parkway) Interchange-Ramp Volume Summary	25
SR 414 (Apopka Expressway) Mainline Volume Summary	29
SR 414 (Apopka Expressway) Interchange-Ramp Volume Summary	30
SR 451 (Western Beltway Connector Road) Mainline Volume Summary	32
SR 451 (Western Beltway Connector Road) Ramp Volume Summary	33
Weekday, Daily and Monthly Adjustment Factors	35

SECTION III – MAINLINE TOLL FACILITY CHARACTERISTICS

Mainline Toll Facility Characteristics Introduction	39
Hiwassee Mainline Toll Facility - SR 408	40
Pine Hills Mainline Toll Facility - SR 408	50
Conway East & West Mainline Toll Facility - SR 408	60
Dean Mainline Toll Facility - SR 408	71
Beachline Mainline Toll Facility - SR 528	81
Dallas Mainline Toll Facility - SR 528	91
John Young Mainline Toll Facility - SR 417	101
Boggy Creek Mainline Toll Facility - SR 417	111
Curry Ford Mainline Toll Facility - SR 417	121
University Mainline Toll Facility - SR 417	131
Independence Mainline Toll Facility - SR 429	141
Forest Lake Mainline Toll Facility - SR 429	151
Coral Hills Mainline Toll Facility - SR 414	161
Goldenrod Mainline Toll Facility - SR 551	171
Ponkan Mainline Toll Facility - SR 453	181

SECTION IV - INTERCHANGES

SR 408 (East-West Expressway) Interchanges	192
SR 50 Spur - Exit 1	193
Good Homes Road - Exit 2	194
Hiwassee Road - Exit 4	195
Kirkman Road - Exit 5	196
Pine Hills Road - Exit 6	197
Old Winter Garden Road/Ortman Road - Exit 7	198
John Young Parkway - Exit 8A	199

Tampa Avenue - Exit 8B	200
Orange Blossom Trail - Exit 9	201
Interstate 4 - Exit 10A	202
Orange Avenue (1) - Entrance	203
Orange Avenue (2) - Exit 10B	204
Rosalind Avenue - Exit 11A	205
Mills Avenue - Exit 11B	206
Bumby Avenue - Exit 12A	207
Crystal Lake Drive - Exit 12B	208
Conway Road - Exit 13	209
Andes Avenue/Semorán Boulevard (SR 436) - Exit 14	210
Semorán Boulevard (SR 436) - Exit 14	211
Yucatan Drive - Entrance	212
Goldenrod Road (SR 551) - Exit 16	213
Chickasaw Trail - Exit 17	214
Central Florida GreeneWay (SR 417) - Exit 18	215
Dean Road - Exit 19	216
Rouse Road - Exit 20	217
Alafaya Trail - Exit 21	218
East Colonial Drive (SR 50) - Exit 23	219
SR 528 (Beachline Expressway) Interchanges	221
Boggy Creek Road - Exit 8	222
Tradeport Drive/Conway Road - Exit 9	223
Semorán Boulevard (SR 436) - Exit 11A & B	224
Goldenrod Road (SR 551) - Exit 12	225
Narcoossee Road (CR 15) - Exit 13	226
Central Florida GreeneWay (SR 417) - Exit 16	227
Monument Parkway - Exit 20	228
Dallas Boulevard - Exit 24	229
SR 520 - Exit 31	230
SR 417 (Central Florida GreeneWay) Interchanges	233
International Drive - Exit 6	235
John Young Parkway - Exit 10	236
US 17-92/US 441/Orange Blossom Trail - Exit 11	237
Florida's Turnpike - Exit 12	238

Landstar Boulevard - Exit 14	239
South Access Road/International Airport/Boggy Creek Road - Exit 17A & B (1)	240
South Access Road/International Airport/Boggy Creek Road - Exit 17A & B (2)	241
Lake Nona Boulevard - Exit 19	242
Narcoossee Road (CR 15) - Exit 22	243
Moss Park Road - Exit 23	244
Dowden Road - Exit 24	245
Beachline Expressway (SR 528) - Exit 26	246
Lee Vista Boulevard - Exit 27	247
Curry Ford Road - Exit 30	248
East-West Expressway (SR 408) - Exit 33A & B	249
East Colonial Drive (SR 50) - Exit 34	250
University Boulevard - Exit 37	251
NB SR 417 Exit to University Boulevard	252
SR 429 (Western Beltway and Wekiva Parkway) Interchanges	254
Schofield Road - Exit 13	255
New Independence Parkway - Exit 15	256
CR 535 - Exit 19	257
Florida's Turnpike/West Colonial Drive (SR 50) - Exit 22/23	258
Plant Street/Franklin Street (SR 438) - Exit 24	259
Plant Street/Franklin Street (SR 438) - Exit 24	260
West Road - Exit 26	261
Ocoee-Apopka Road (CR 437A) - Exit 29	262
Apopka Expressway (SR 414) - Exit 30	263
SR 429/SR 414 at US 441/Connector Road/CR 437	264
Kelly Park Road - Exit 38	265
SR 414 (Apopka Expressway) Interchanges	267
SR 451 - Exit 4A	268
Western Beltway (SR 429) - Exit 4B	269
Marden Road - Exit 5	270
Keene Road - Exit 6	271
Hiwassee Road - Exit 8	272
Orange Blossom Trail (US 441) - Exit 9	273

SR 451 (Western Beltway Connector Road) Interchanges	275
SR 414 East/SR 429 South	276
Orange Blossom Trail (US 441)	277

SECTION V - GENERAL STATISTICS

General Statistics Introduction	278
Expressway Mileage and Total Lane Miles	279
Toll Facilities Lane Summary	280
Toll Rate Schedule	284
SR 408 Distance Between Interchanges	288
SR 528 Distance Between Interchanges	293
SR 417 Distance Between Interchanges	294
SR 429 Distance Between Interchanges	298
SR 451 Distance Between Interchanges	299
SR 414 Distance Between Interchanges	300
SR 408 Toll Rates Between Interchanges	302
SR 528 Toll Rates Between Interchanges	307
SR 417 Toll Rates Between Interchanges	308
SR 429 Toll Rates Between Interchanges	312
SR 414 Toll Rates Between Interchanges	313
SR 408 Cost per Mile Between Interchanges	315
SR 528 Cost per Mile Between Interchanges	320
SR 417 Cost per Mile Between Interchanges	321
SR 429 Cost per Mile Between Interchanges	325
SR 414 Cost per Mile Between Interchanges	326

Executive Summary

The Central Florida Expressway Authority (CFX) system includes 118 centerline miles (including the new Wekiva Parkway and SR 453), 815 lane miles (including ramps), 69 interchanges, 335 bridges and 17 mainline toll facilities. CFX's system includes SR 408 (Spessard L. Holland Expressway and Arnold Palmer Expressway),

SR 528 (Martin Andersen Beachline Expressway), SR 417 (Central Florida GreeneWay), SR 429 (Western Beltway and Wekiva Parkway), SR 414 (Apopka Expressway), SR 451 and SR 453. On average, over a million toll transactions are recorded every day. CFX is authorized to build, operate and maintain a transportation facility in Central Florida, incorporating Lake, Orange, Osceola and Seminole counties. On July 1, 2017, by order of the Florida House Bill 299, the geographical boundary of Brevard County was added to the area served by the CFX. This five-county region has more than 3 million residents and over 68 million visitors annually.

“To provide the region with a world-class, integrated mobility network that drives economic prosperity and quality of life”

Vision Statement

Towards the goal of a world-class system, and the strategic priority to build a customer-driven organization, CFX prepares this manual to provide a complete set of data relating to traffic volumes, traffic characteristics, toll facility operations and interchange lane configurations for their system. This data is utilized to project traffic trends and identify future capacity improvement projects within the system that can then be included into the Five-Year Work Plan.

In the last year, overall traffic increased on the system by 7.7%. Mainline volume changes range from -1.3% to 28.5%. Of particular interest are the segments of roadways at the ends of the spectrum:

- SR 408 (Interstate 4 to Alafaya Trail) average growth of less than 2%
- SR 528 (Boggy Creek Road to Tradeport Drive) only segment of roadway with a decrease in volume at -1%. This segment of roadway has been under construction by CFX since 2015 and by Florida's Turnpike since 2017. The tolling scheme was also modified from mainline tolling to ramp tolling.
- SR 417 (International Drive to Landstar Boulevard) over 20% growth
- SR 417 (South Access (OIA)/Boggy Creek Road to Lake Nona Boulevard) 19% growth
- SR 429 (Seidel Road to CR 535) over 19% growth

The Orlando Metropolitan area (Lake, Orange, Osceola and Seminole counties) is expected to continue to grow at a rate above national average. Based on the 2017 U.S. Census, for the second year in a row, the Orlando Metropolitan area was ranked number eight in the country for growth at approximately 2.3%. According to the Orlando Sentinel, Osceola County is the second-fastest-growing county in the state, just behind Walton County, and was ranked tenth in the nation.

The data collected and detailed in this report is a snapshot in time. It should be noted that this data varies with time due to a number of influences. Factors such as construction and weather can affect the routes that drivers choose to travel. Some of the activities controlled by CFX that may influence traffic data include:

- Expansion Projects
 - SR 429 (Wekiva Parkway)
 - SR 453
- Existing System Capacity Improvements (Complete and Under construction)
 - 253F SR 408 / SR 417 Interchange Improvements Phase I
 - 253G SR 408 / SR 417 Interchange Improvements Phase II
 - 408-127 Widening SR 408 from Good Homes Road to Hiawassee Road
 - 408-128 Widening SR 408 from SR 417 to Alafaya Trail
 - 528-405 SR 528 Airport Mainline Toll Plaza Demolition & Ramp Plaza Construction
- New and/or Modified Interchanges
 - SR 408/Interstate 4 Ultimate Interchange (In partnership with others)
 - 528-313 SR 528 / Innovation Way Interchange
 - SR 417 / Florida's Turnpike Interchange Improvements (By others)
- Toll Suspensions
 - Due to Hurricane Matthew, tolls were suspended from 10/5/16 through 10/10/16
 - Due to Hurricane Irma, tolls were suspended from 9/5/17 through 9/20/17
- Toll Rate Changes
 - FDOT toll rate increase of \$0.25 for cash payment at the Dallas Mainline Toll Plaza October 2017

The data collected in April 2017 and October 2017 is summarized in the following sections.

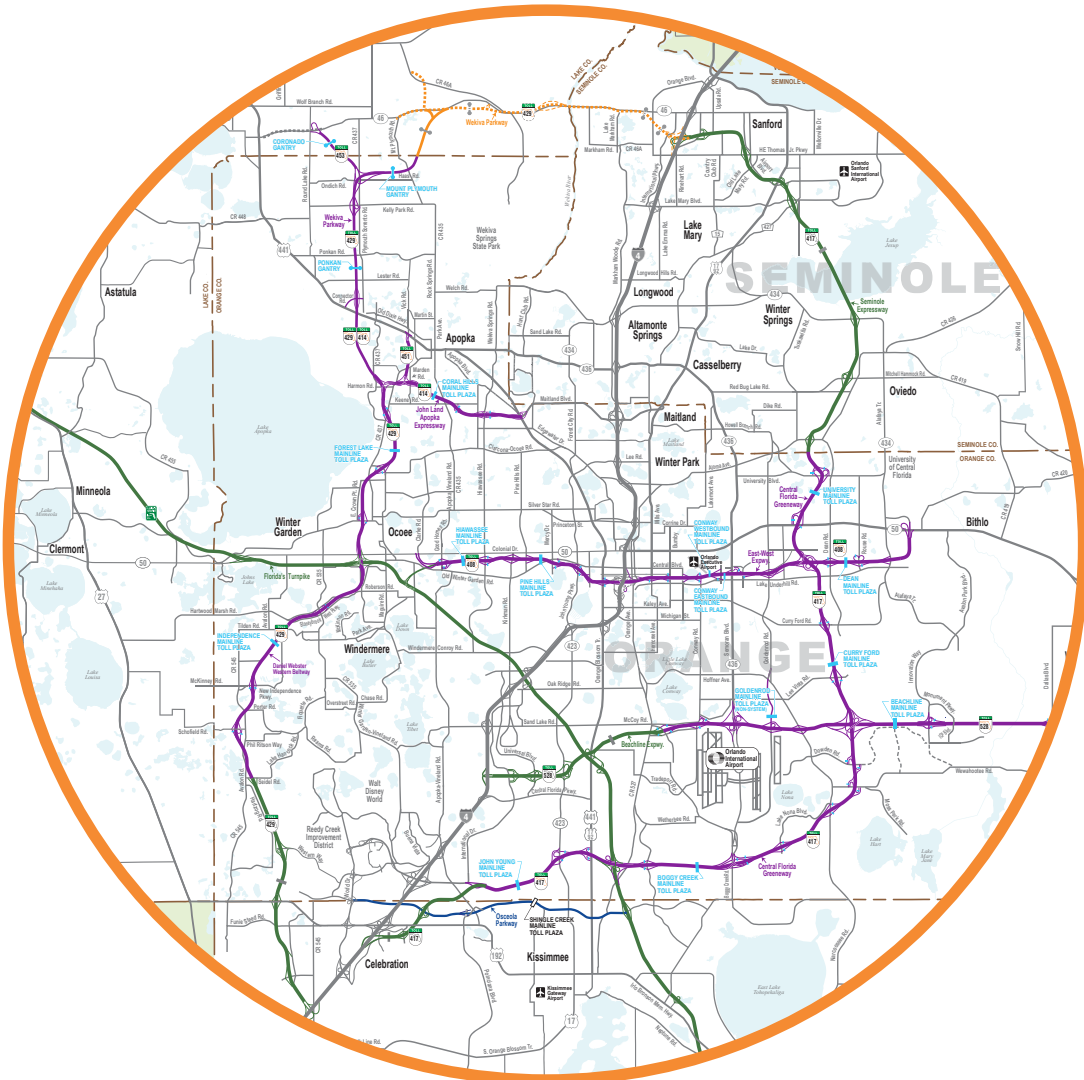

Section I: System Maps



2017 Traffic Data and Statistics Manual
 CENTRAL FLORIDA EXPRESSWAY AUTHORITY

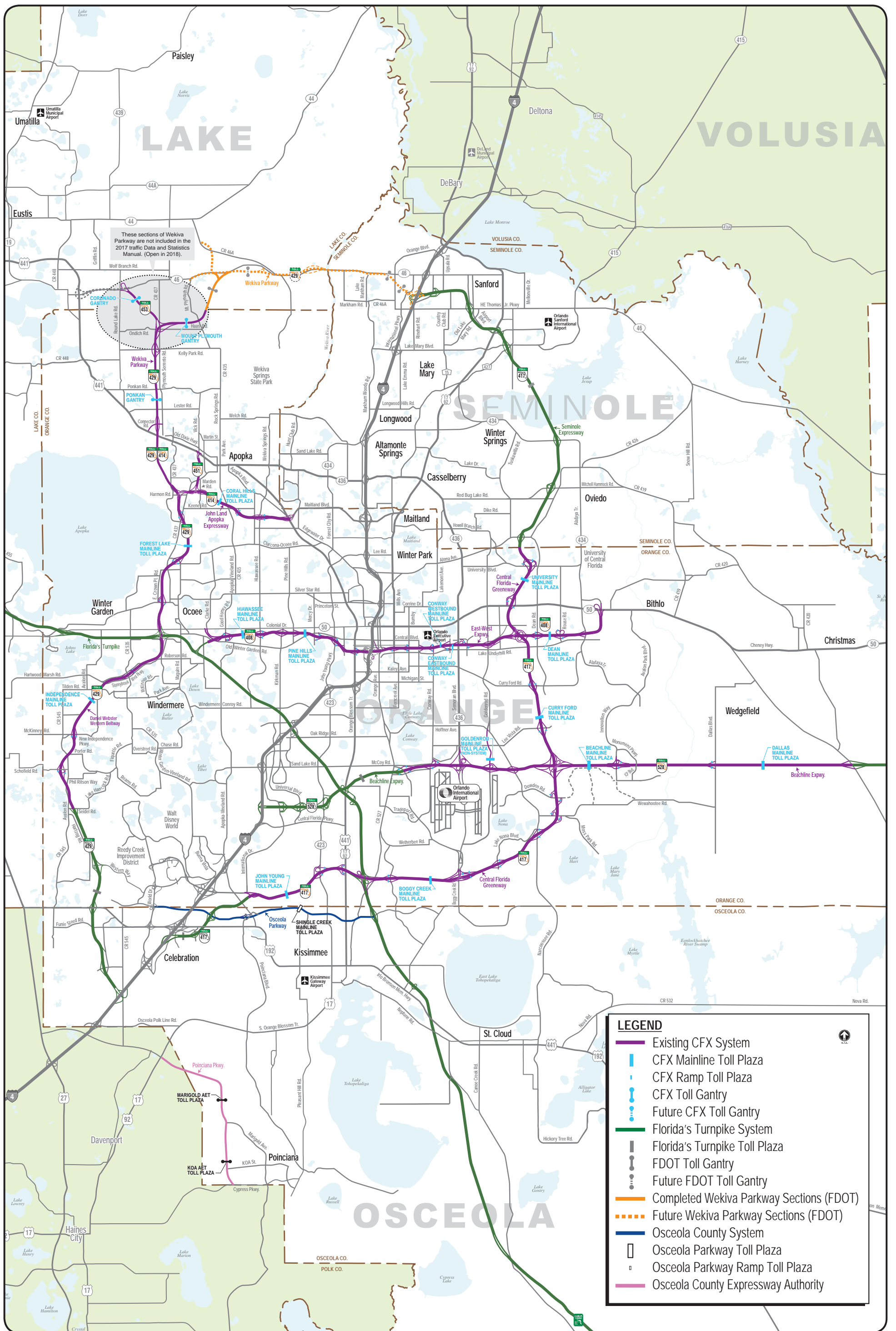

These sections of Wekiva Parkway are not included in the 2017 traffic Data and Statistics Manual. (Open in 2018).

LEGEND

- Existing CFX System
- CFX Mainline Toll Plaza
- CFX Ramp Toll Plaza
- CFX Toll Gantry
- Future CFX Toll Gantry
- Florida's Turnpike System
- Florida's Turnpike Toll Plaza
- FDOT Toll Gantry
- Future FDOT Toll Gantry
- Completed Wekiva Parkway Sections (FDOT)
- - - Future Wekiva Parkway Sections (FDOT)
- Osceola County System
- Osceola Parkway Toll Plaza
- Osceola Parkway Ramp Toll Plaza
- Osceola County Expressway Authority

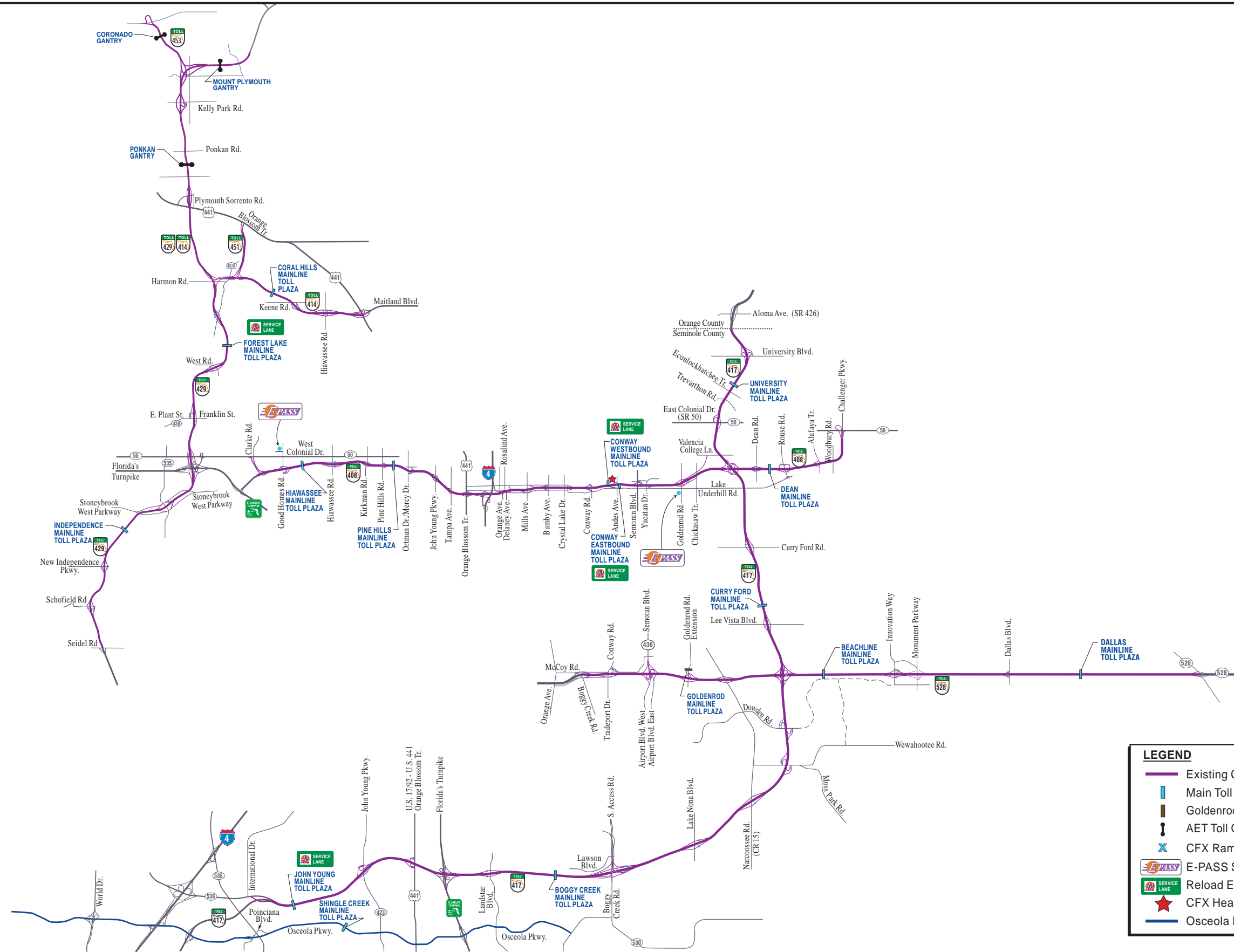

LEGEND

- Existing CFX System
- Main Toll Plaza
- Goldenrod Toll Facility (non-system)
- AET Toll Gantry
- CFX Ramp Toll Plaza
- E-PASS Service Center
- Reload E-PASS Service Lane
- CFX Headquarters
- Osceola Parkway



Section II: Traffic Counts

2017 Traffic Data and Statistics Manual
CENTRAL FLORIDA EXPRESSWAY AUTHORITY

Traffic Counts Introduction

Traffic data was collected for Monday thru Friday for the entire month of April 2017 utilizing the Wavetronics Data Collection Sensors (SS125 HD) recently installed throughout the CFX system. Traffic data was also collected for October 2017 utilizing the Wavetronics Data Collection Sensors (SS125 HD) and Toll Plaza data was collected for April 2017. Traffic data collected at the ramp and mainline toll plazas for the same five days is also utilized to calculate the Average Annual Weekday Traffic (AAWT). The data collection for this manual was completed during the month of April 2017 at the appropriate interchange ramp and mainline locations.

Monthly adjustment factors used to convert 24-hour weekday traffic counts to AAWT, are presented for each mainline segment and their accompanying ramps. These factors are based on the daily transaction information received from CFX for the mainline toll plazas monthly transaction records for the most recent year unaffected by toll adjustments and major system additions. For example, if a 24-hour roadway count is collected on a normal weekday in April at a certain location, then that count would be multiplied by the appropriate monthly (April) factor to convert it to an average annual weekday volume. This normalizes the variations in weekly and monthly traffic so that counts taken at different times in the year can be compared.

The following pages contain estimates of AAWT for all mainline sections, and ramps associated with the CFX system facilities. The data includes the most recent observations, as well as historical traffic volumes starting from the year 2007 (where applicable).

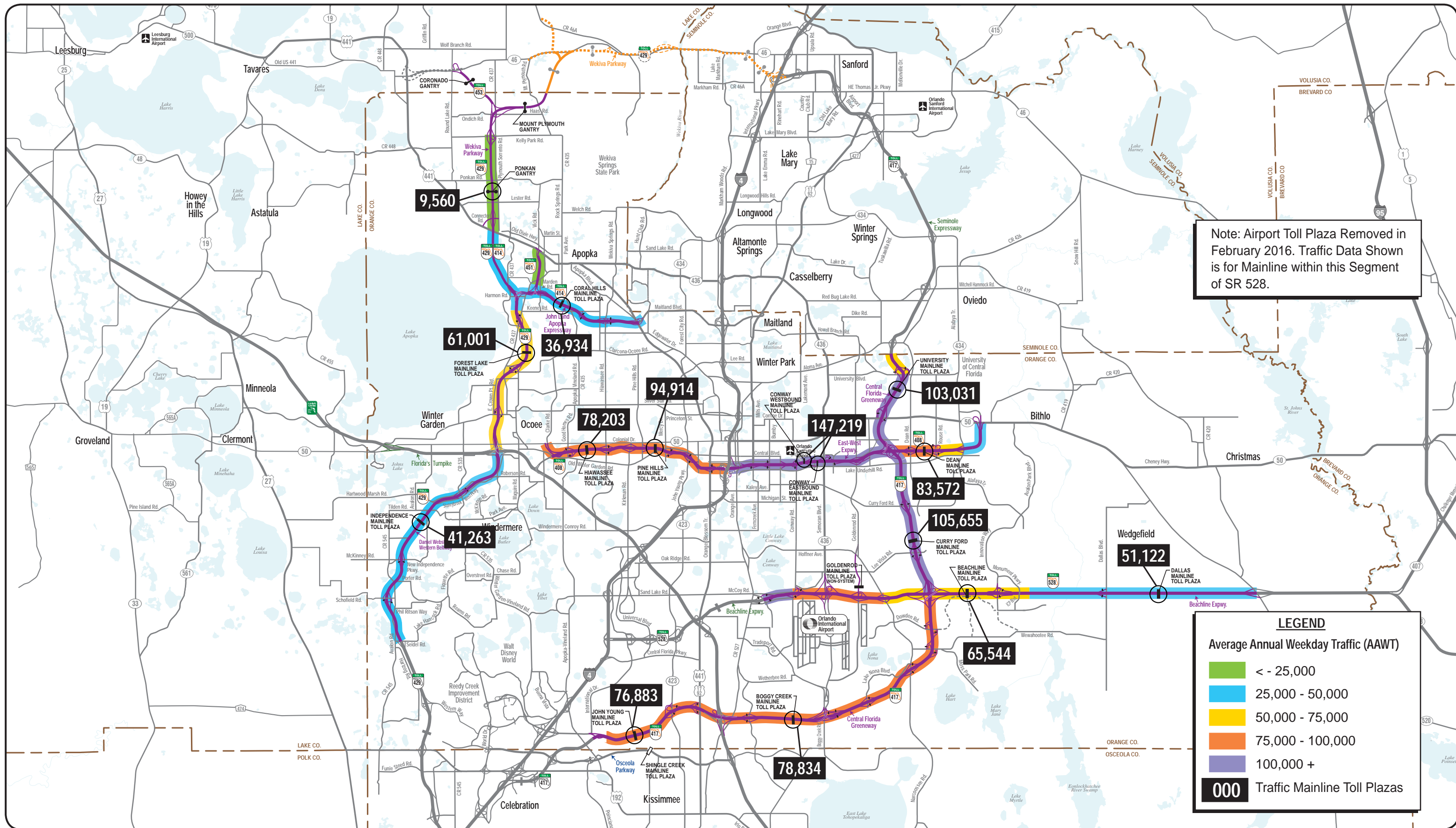

Note: Airport Toll Plaza Removed in February 2016. Traffic Data Shown is for Mainline within this Segment of SR 528.

East-West Expressway



Existing and Historical Average Annual Weekday Mainline Traffic Volumes

Location	Year 2007	Year 2008	Year 2009	Year 2010	Year 2011	Year 2012	Year 2013	Year 2014	Year 2015	Year 2016	Year 2017
Florida Turnpike to SR 50 Spur / Clarke Road	49,570	46,980	42,220	42,740	44,580	44,130	46,360	50,710	57,450	62,830	68,380
SR 50 Spur / Clarke Road to Good Homes Road	63,110	58,890	53,740	54,560	55,030	53,930	56,070	60,500	68,170	73,650	78,140
Good Homes Road to Hiwassee Road	66,820	61,560	55,900	56,680	57,170	56,330	57,750	61,440	69,490	73,510	77,260
Hiwassee Road to Kirkman Road	73,185	67,950	60,950	62,250	62,410	60,960	62,410	66,730	73,490	76,680	81,550
Kirkman Road to Pine Hills Road	75,975	71,650	64,690	65,860	66,770	65,970	66,710	71,580	78,780	81,440	84,970
Pine Hills Road to Old Winter Garden Road	82,710	77,780	69,800	71,150	72,070	71,190	72,020	77,210	85,210	89,080	92,690
Old Winter Garden Road to John Young Parkway	86,760	81,790	73,190	74,880	75,820	74,850	76,310	81,130	90,450	94,740	98,820
John Young Parkway to Tampa Avenue	86,440	83,380	74,660	76,850	77,910	77,060	78,730	83,890	93,600	97,370	101,430
Tampa Avenue to US 441 (Orange Blossom Trail)	83,840	81,140	72,660	74,930	76,000	75,200	76,940	81,830	91,110	93,780	98,310
US 441 (Orange Blossom Trail) to Interstate 4 (I-4)	84,350	82,050	74,065	76,870	77,480	76,990	79,710	84,860	93,810	96,210	102,400
Interstate 4 (I-4) to Rosalind Avenue	108,460	100,810	108,040	112,550	116,620	113,060	114,050	118,820	127,860	135,130	138,600
Rosalind Avenue to Mills Avenue	127,590	119,820	126,480	130,650	134,260	131,970	132,930	139,470	152,210	157,830	160,300
Mills Avenue to Bumby Avenue	136,390	131,040	133,680	139,600	143,050	140,210	141,140	147,810	160,220	166,820	168,710
Bumby Avenue to Crystal Lake Drive	125,080	119,590	122,430	128,130	131,380	128,970	128,590	135,300	146,110	152,210	154,830
Crystal Lake Drive to Conway Road	138,170	132,850	132,200	138,930	141,490	138,810	136,320	144,420	157,950	165,780	169,430
Conway Road to Andes Avenue	124,790	120,130	120,900	127,020	129,090	127,170	125,460	132,760	144,880	152,970	156,110
Andes Avenue to SR 436 / Yucatan Drive	118,110	112,240	112,750	117,830	119,600	117,530	115,530	122,400	132,940	140,380	143,970
SR 436 / Yucatan Drive to Goldenrod Rd/Chickasaw Trail	109,340	110,690	111,380	115,600	116,310	114,450	116,930	123,510	131,920	139,480	141,600
Goldenrod Rd/Chickasaw Trail to SR 417 (Central Fl GreeneWay)	103,300	104,150	104,230	109,580	107,280	102,280	103,730	109,630	117,270	124,240	125,510
SR 417 (Central Fl GreeneWay) to Dean Road	80,680	75,540	74,290	77,070	76,040	76,500	75,280	78,960	84,230	89,950	90,340
Dean Road to Rouse Road	70,100	65,990	65,900	68,130	66,670	67,200	67,320	71,110	74,180	79,580	80,340
Rouse Road to Alafaya Trail	63,270	59,670	59,650	61,080	59,680	59,850	59,150	64,030	66,260	69,410	70,630
Alafaya Trail to SR 50 (East Colonial Drive)	29,670	31,120	32,530	33,300	33,340	33,060	33,990	34,780	37,460	38,440	40,980

Notes:

1. SR 408 under construction in Years 2006-2011 from Interstate 4 (I-4) to Goldenrod Rd/Chickasaw Trail.
2. \$.25 Toll Increase was applied systemwide at various locations in April 2009 and 2012.
3. SR 408 under construction in Years 2015-2017 at the Interstate 4 (I-4) Interchange (I-4 Ultimate). Orange Avenue WB On Ramp closed in Years 2016-2017.
4. SR 408 under construction from Good Homes Road to Hiwassee Road in 2017.
5. SR 408/SR 417 Interchange under construction by projects 408-253 F/G.



SR 408 (EAST-WEST EXPRESSWAY) Mainline Volume Summary

Existing and Historical Average Annual Weekday Ramp Terminal Traffic Volumes

Ramp Location	Year 2007	Year 2008	Year 2009	Year 2010	Year 2011	Year 2012	Year 2013	Year 2014	Year 2015	Year 2016	Year 2017
Exit 1 : SR 50 / Clarke Road Spur											
Eastbound On-Ramp	7,050	6,150	6,040	6,220	5,640	5,310	5,050	5,510	5,600	5,580	4,930
Westbound Off-Ramp	6,490	5,760	5,480	5,600	4,810	4,490	4,330	4,450	4,840	4,670	4,510
Exit 2 : Good Homes Road											
Eastbound Off-Ramp	2,650	2,950	2,840	3,150	3,430	3,430	3,690	4,010	4,630	5,300	5,660
Westbound On-Ramp	2,740	2,830	3,090	3,440	3,540	3,640	3,940	4,320	4,940	5,720	6,440
Eastbound On-Ramp	4,490	4,330	4,070	4,350	4,540	4,820	4,500	4,840	5,480	5,850	5,520
Westbound Off-Ramp	4,610	4,120	4,020	4,360	4,570	4,650	4,320	4,620	5,230	5,590	5,450
Exit 4 : Hiawasse Road											
Eastbound Off-Ramp	3,680	2,770	2,310	2,440	2,360	2,310	2,330	2,630	2,960	3,250	2,260
Westbound On-Ramp	3,710	2,910	2,420	2,430	2,330	2,160	2,240	2,550	2,960	3,350	3,720
Eastbound On-Ramp	7,180	6,340	5,220	5,550	5,310	4,810	4,920	5,410	5,990	6,190	6,280
Westbound Off-Ramp	6,575	5,730	4,560	4,890	4,620	4,290	4,270	4,780	5,000	5,210	5,740
Exit 5 : Kirkman Road											
Eastbound Off-Ramp	4,560	4,270	3,530	3,820	3,440	3,370	3,330	3,690	3,570	4,020	4,430
Westbound On-Ramp	5,190	4,010	3,370	3,950	3,190	3,110	3,210	3,510	3,720	4,220	4,480
Eastbound On-Ramp	6,280	6,110	5,560	6,090	5,900	6,170	7,740	6,180	6,760	6,770	6,640
Westbound Off-Ramp	6,260	5,870	5,080	5,290	5,090	5,320	6,550	5,440	5,840	6,140	5,870
Exit 6 : Pine Hills Road											
Eastbound On-Ramp	3,620	3,200	2,740	2,850	2,900	2,950	2,760	2,990	3,390	3,650	3,600
Westbound Off-Ramp	3,115	2,930	2,370	2,440	2,400	2,270	2,550	2,620	2,080	2,300	1,840

Notes:

- SR 408 under construction in Years 2006-2011 from Interstate 4 (I-4) to Goldenrod Rd/Chickasaw Trail.
- \$.025 Toll increase was applied systemwide at various locations in April 2009 and 2012.
- SR 408 under construction in Years 2015-2017 at the Interstate 4 (I-4) Interchange (I-4 Ultimate). Orange Avenue WB On Ramp closed in Years 2016-2017.
- SR 408 under construction from Good Homes Road to Hiawasse Road in 2017.
- SR 408/SR 417 Interchange under construction by projects 408-253 F/G.

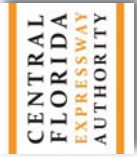

SR 408 (EAST-WEST EXPRESSWAY) Interchange - Ramp Volume Summary

Existing and Historical Average Annual Weekday Ramp Terminal Traffic Volumes

Ramp Location	Year 2007	Year 2008	Year 2009	Year 2010	Year 2011	Year 2012	Year 2013	Year 2014	Year 2015	Year 2016	Year 2017
Exit 7 : Old Winter Garden Road											
Eastbound On-Ramp	1,920	1,870	1,600	1,750	1,770	1,750	1,880	2,130	2,230	2,490	2,690
Westbound Off-Ramp	2,130	2,140	1,790	1,980	1,980	1,910	2,050	2,280	2,540	2,790	3,060
Exit 8A : John Young Parkway											
Eastbound Off-Ramp	4,950	4,360	3,440	3,660	3,810	3,920	3,110	3,220	3,680	3,850	3,910
Westbound On-Ramp	6,950	4,130	3,940	3,760	3,590	3,620	3,420	3,740	4,320	4,700	4,630
Eastbound On-Ramp	6,050	5,340	4,130	5,020	5,270	5,540	5,310	5,680	6,660	6,740	6,800
Westbound Off-Ramp	5,530	4,740	4,720	4,370	4,220	4,210	4,240	4,320	4,690	4,700	4,850
Exit 8B : Tampa Avenue											
Eastbound Off-Ramp	1,240	1,080	990	930	970	870	880	1,030	1,210	1,660	1,900
Westbound On-Ramp	1,360	1,160	1,010	990	940	990	1,040	1,140	1,300	1,810	1,880
Exit 9 : Orange Blossom Trail (US 441)											
Eastbound Off-Ramp	3,620	3,090	2,660	2,610	2,690	2,600	2,570	2,770	3,130	3,690	3,720
Westbound On-Ramp	4,330	3,300	2,740	2,770	2,850	2,650	2,690	2,930	3,170	3,870	3,520
Eastbound On-Ramp	4,120	3,720	3,400	3,720	3,690	3,640	3,970	4,280	4,660	5,170	5,580
Westbound Off-Ramp	4,340	3,580	3,405	3,600	3,330	3,400	3,690	3,920	4,160	4,530	5,140
Exit 10A/B : Interstate 4											
SR 408 Eastbound Off-Ramp to WB I-4	12,250	3,640	3,535	3,400	3,300	3,160	2,470	3,390	3,330	3,270	3,840
SR 408 Eastbound Off-Ramp to EB I-4	-----	9,090	7,980	8,020	7,920	7,940	7,510	7,640	7,440	7,240	8,580
SR 408 Westbound On-Ramp from I-4	11,100	11,590	8,685	8,070	8,040	7,560	7,340	8,280	9,205	10,130	9,320
SR 408 Eastbound On-Ramp from I-4	30,390	30,910	31,650	31,560	23,920	30,890	29,950	33,780	36,185	38,590	28,400

Notes:

- SR 408 under construction in Years 2006-2011 from Interstate 4 (I-4) to Goldenrod Rd/Chickasaw Trail.
- \$0.25 Toll Increase was applied systemwide at various locations in April 2009 and 2012.
- SR 408 under construction in Years 2015-2017 at the Interstate 4 (I-4) Interchange (I-4 Ultimate). Orange Avenue WB On Ramp closed in Years 2016-2017.
- SR 408 under construction from Good Homes Road to Hiwassee Road in 2017.
- SR 408/SR 417 Interchange under construction by projects 408-253 F/G.



SR 408 (EAST-WEST EXPRESSWAY) Interchange - Ramp Volume Summary

Existing and Historical Average Annual Weekday Ramp Terminal Traffic Volumes

Ramp Location	Year 2007	Year 2008	Year 2009	Year 2010	Year 2011	Year 2012	Year 2013	Year 2014	Year 2015	Year 2016	Year 2017
Exit 10A/B : Interstate 4 (continued)											
SR 408 Westbound Off-Ramp to WB I-4	29,240	20,660	23,510	22,830	22,790	22,900	21,490	21,630	22,020	22,410	18,170
SR 408 Westbound Off-Ramp to EB I-4	-----	6,370	13,655	15,000	14,510	14,730	14,080	12,990	10,770	8,550	10,990
Interstate 4 Westbound Off-Ramp	19,250	21,140	21,080	19,770	16,300	22,830	22,140	25,740	28,140	30,540	22,010
Interstate 4 Westbound On-Ramp	22,500	24,300	26,420	26,230	26,090	26,060	23,960	25,020	25,350	25,680	24,680
Interstate 4 Eastbound Off-Ramp to SR 408	22,620	21,360	18,410	19,860	15,660	15,620	15,150	16,320	17,250	18,180	16,180
Exit 10C : Orange Avenue											
Eastbound Off-Ramp	10,450	13,200	9,530	7,100	6,890	6,930	6,800	6,820	7,320	7,270	7,530
Westbound On-Ramp	9,170	5,730	5,110	5,470	5,500	5,500	5,430	5,720	6,520	-----	-----
Exit 11A : Rosalind Avenue											
Eastbound On-Ramp	9,140	9,790	8,670	9,190	9,540	10,200	9,280	9,830	12,090	11,670	12,390
Westbound Off-Ramp	9,990	9,220	9,770	8,910	8,100	8,710	9,640	10,340	10,850	6,190	10,250
Exit 11B : Mills Avenue											
Eastbound Off-Ramp	1,330	1,250	1,070	1,100	1,050	1,080	1,080	1,200	1,430	1,570	1,610
Eastbound On-Ramp	4,570	8,370	4,050	4,300	4,280	4,300	4,510	5,300	5,590	6,250	6,160
Westbound Off-Ramp	5,560	4,100	4,220	5,750	5,560	5,020	4,070	4,260	4,420	4,820	5,370
Exit 12A : Bumby Avenue											
Eastbound Off-Ramp	5,600	5,470	5,420	5,330	5,460	5,330	5,180	5,580	6,300	6,380	6,800
Westbound On-Ramp	5,710	5,980	5,830	6,140	6,210	5,910	5,890	6,580	7,280	7,780	8,230
Exit 12B : Crystal Lake Drive											
Eastbound On-Ramp	6,560	8,110	4,660	5,580	5,130	4,910	4,920	5,590	5,890	6,530	6,800
Westbound Off-Ramp	6,530	5,150	5,110	5,220	4,980	4,930	5,600	6,210	6,760	7,330	8,010

Notes:

- SR 408 under construction in Years 2006-2011 from Interstate 4 (I-4) to Goldenrod Rd/Chickasaw Trail.
- \$0.25 Toll Increase was applied systemwide at various locations in April 2009 and 2012.
- SR 408 under construction in Years 2015-2017 at the Interstate 4 (I-4) Interchange (I-4 Ultimate). Orange Avenue WB On Ramp closed in Years 2016-2017.
- SR 408 under construction from Good Homes Road to Hiwassee Road in 2017.
- SR 408/SR 417 Interchange under construction by projects 408-253 F/G.



SR 408 (EAST-WEST EXPRESSWAY) Interchange - Ramp Volume Summary

Existing and Historical Average Annual Weekday Ramp Terminal Traffic Volumes

Ramp Location	Year 2007	Year 2008	Year 2009	Year 2010	Year 2011	Year 2012	Year 2013	Year 2014	Year 2015	Year 2016	Year 2017
Exit 13 : Conway Road											
Eastbound Off-Ramp	6,390	5,880	5,120	5,530	5,730	5,430	5,180	5,470	5,990	6,270	6,350
Westbound On-Ramp	6,990	6,840	6,180	6,380	6,670	6,210	5,680	6,190	6,280	6,680	7,010
Exit 14 : SR 436 / Andes Ave											
Eastbound Off-Ramp to Andes Ave / SR 436	6,680	7,890	7,700	8,780	9,010	9,170	9,440	9,950	11,030	11,650	11,570
Westbound On-Ramp from SR 436 SB	7,250	5,210	4,790	5,240	5,410	5,350	5,450	5,870	6,790	7,270	6,810
Westbound On-Ramp from SR 436 NB	8,210	4,670	4,920	5,670	6,130	5,620	5,430	5,690	6,480	6,650	6,760
Eastbound On-Ramp from Yucatan Dr	3,370	4,580	4,420	4,380	3,950	3,920	4,230	4,540	4,990	5,320	5,330
Westbound Off-Ramp to SR 436	3,320	3,750	3,920	4,300	4,300	3,970	4,510	5,030	5,600	5,860	5,870
Westbound On-Ramp from Andes Ave	-----	-----	450	410	480	470	490	410	580	680	810
Exit 16 : Goldenrod Road (SR 551)											
Eastbound Off-Ramp	10,580	9,970	9,480	10,240	10,480	10,660	7,310	7,510	8,160	6,190	8,190
Westbound On-Ramp	9,700	9,620	9,570	10,110	10,060	11,040	6,800	7,210	7,570	7,770	7,720
Eastbound On-Ramp	7,130	6,680	6,060	6,930	5,790	4,580	4,900	5,510	6,040	6,570	6,340
Westbound Off-Ramp	7,110	6,370	5,840	7,400	5,720	4,950	5,370	5,570	6,210	6,550	7,580
Exit 17 : Chickasaw Trail											
Eastbound Off-Ramp	-----	-----	-----	-----	-----	-----	4,850	5,510	5,700	6,610	6,720
Westbound On-Ramp	-----	-----	-----	-----	-----	-----	4,320	4,750	5,550	6,440	7,580
Exit 18 : SR 417 (Central Florida GreeneWay)											
Eastbound Off-Ramp to SB SR 417	7,200	6,400	6,700	7,080	6,950	7,310	7,530	8,620	9,880	11,040	10,690
Eastbound Off-Ramp to NB SR 417	-----	-----	-----	-----	-----	15,090	15,450	16,160	17,540	18,470	18,730
Westbound On-Ramp from NB SR 417	7,770	6,920	7,100	7,530	8,050	8,170	8,190	8,180	10,520	11,910	11,350

Notes:

- SR 408 under construction in Years 2006-2011 from Interstate 4 (I-4) to Goldenrod Rd/Chickasaw Trail.
- \$.025 Toll Increase was applied systemwide at various locations in April 2009 and 2012.
- SR 408 under construction in Years 2015-2017 at the Interstate 4 (I-4) Interchange (I-4 Ultimate). Orange Avenue WB On Ramp closed in Years 2016-2017.
- SR 408 under construction from Good Homes Road to Hiwassee Road in 2017.
- SR 408/SR 417 Interchange under construction by projects 408-253 F/G.



SR 408 (EAST-WEST EXPRESSWAY) Interchange - Ramp Volume Summary

Existing and Historical Average Annual Weekday Ramp Terminal Traffic Volumes

Ramp Location	Year 2007	Year 2008	Year 2009	Year 2010	Year 2011	Year 2012	Year 2013	Year 2014	Year 2015	Year 2016	Year 2017
Exit 18 : SR 417 (Central Florida GreeneWay) (cont.)											
Westbound On-Ramp from SB SR 417	-----	-----	-----	-----	15,980	15,290	15,590	15,980	16,970	18,080	18,450
Eastbound On-Ramp from NB SR 417	7,530	7,210	6,080	6,220	6,230	6,340	6,040	6,030	7,230	7,660	8,180
Eastbound On-Ramp from SB SR 417	4,430	5,960	3,645	3,620	3,900	3,480	3,430	3,740	4,000	4,590	4,790
Westbound Off-Ramp to NB SR 417	4,580	4,130	3,975	4,220	4,020	3,410	3,590	3,870	4,250	4,770	4,920
Westbound Off-Ramp to SB SR 417	7,680	6,980	6,520	6,380	6,250	6,850	5,830	6,210	7,130	7,780	8,550
Exit 19 : Dean Road											
Eastbound Off-Ramp	6,210	5,660	4,960	5,220	5,390	5,560	5,300	4,870	5,490	5,940	5,990
Westbound On-Ramp	6,850	6,360	5,780	6,260	6,240	6,120	5,980	5,750	6,280	7,050	7,490
Eastbound On-Ramp	1,200	1,270	1,200	1,220	1,180	1,270	1,560	1,430	1,440	1,760	1,570
Westbound Off-Ramp	1,280	1,200	1,150	1,320	1,080	1,110	1,090	1,380	1,420	1,680	1,400
Exit 20 : Rouse Road											
Eastbound Off-Ramp	4,770	4,240	4,210	4,550	4,690	4,790	4,410	5,290	5,670	5,990	5,950
Westbound On-Ramp	3,910	3,800	3,530	3,950	3,590	3,720	3,730	4,400	4,800	5,750	5,330
Eastbound On-Ramp	950	890	760	710	660	610	670	730	740	830	710
Westbound Off-Ramp	900	830	730	740	630	550	550	650	720	760	680
Exit 21 : Alafaya Trail											
Eastbound Off-Ramp	16,140	14,540	13,480	13,770	12,850	13,240	12,430	13,600	14,640	15,150	14,430
Westbound On-Ramp	17,460	14,010	13,640	14,010	13,490	13,550	12,730	14,660	15,330	16,000	15,520
Exit 23 : SR 50 (East Colonial Drive)											
Eastbound Off-Ramp	12,450	13,170	11,110	11,450	13,080	11,200	11,700	11,900	12,900	12,070	13,210
Westbound On-Ramp from EB SR 50	1,480	1,330	1,310	1,420	1,380	1,290	1,430	1,570	2,040	2,210	2,230
Westbound On Ramp from WB SR 50	11,460	10,680	10,480	11,770	10,410	10,300	9,930	9,970	10,890	10,360	12,250

Notes:

- SR 408 under construction in Years 2006-2011 from Interstate 4 (I-4) to Goldenrod Rd/Chickasaw Trail.
- \$.025 Toll Increase was applied systemwide at various locations in April 2009 and 2012.
- SR 408 under construction in Years 2015-2017 at the Interstate 4 (I-4) Interchange (I-4 Ultimate). Orange Avenue WB On Ramp closed in Years 2016-2017.
- SR 408 under construction from Good Homes Road to Hiwassee Road in 2017.
- SR 408/SR 417 Interchange under construction by projects 408-253 F/G.



SR 408 (EAST-WEST EXPRESSWAY) Interchange - Ramp Volume Summary

Beachline Expressway



Existing and Historical Average Annual Weekday Mainline Traffic Volumes

Location	Year 2007	Year 2008	Year 2009	Year 2010	Year 2011	Year 2012	Year 2013	Year 2014	Year 2015	Year 2016	Year 2017
Boggy Creek Road to Tradeport Drive	93,290	85,700	85,340	88,765	90,780	94,310	92,200	98,510	104,530	110,540	109,140
Tradeport Drive to SR 436 (Semoran Boulevard)	82,400	76,260	75,200	77,840	78,680	80,840	80,730	83,820	91,280	98,740	109,020
SR 436 (Semoran Boulevard) to Goldenrod Road	74,940	67,780	64,245	64,450	67,700	68,610	71,910	73,760	79,710	85,770	93,500
Goldenrod Road to Narcoossee Road	75,590	68,070	65,670	65,350	68,710	69,920	73,700	75,190	81,920	89,020	97,000
Narcoossee Road to SR 417 (Central Fl GreeneWay)	61,760	55,610	53,280	54,080	55,910	54,280	58,270	60,730	65,110	70,470	76,630
SR 417 (Central Florida GreeneWay) to Monument Pkwy/ICP	47,700	42,450	43,300	46,300	46,880	48,430	49,230	53,510	56,120	60,710	64,640
Monument Pkwy/ICP to Dallas Boulevard	45,260	40,160	41,430	43,730	42,190	41,910	43,390	46,460	49,590	52,470	56,090
Dallas Boulevard to SR 520	41,210	35,650	37,910	39,580	38,730	38,360	39,190	40,890	45,530	46,880	50,590

Notes:

1. SR 528 under construction in the Years 2007-2008 at the SR 436 Interchange.
2. SR 528 under construction in the Years 2007-2008 at the Narcoossee Road Interchange.
3. SR 528 under construction in the Years 2008 - 2009 at the Beachline Main Mainline Toll Plaza.
4. \$0.25 Toll Increase was applied systemwide at various locations in April 2009 and 2012.
5. SR 528 under construction in the Years 2010-2012 at Dallas Boulevard and the new Dallas Mainline Toll Plaza.
6. Systemwide Toll Increase was applied in July 2012 that included different toll rates for E-PASS and Cash customers.
7. SR 528 under construction in the Year 2013 for bridge deck replacements at Tradeport Drive, Daetwyler Drive and Via Flora Drive.
8. SR 528 under construction in the Year 2015 & 2016 widening and Airport Mainline Toll Plaza removal from Boggy Creek to SR 436.
9. SR 528 and Innovation Way interchange / ICP interchange removal under construction 2017.



Existing and Historical Average Annual Weekday Ramp Terminal Traffic Volumes

Ramp Location	Year 2007	Year 2008	Year 2009	Year 2010	Year 2011	Year 2012	Year 2013	Year 2014	Year 2015	Year 2016	Year 2017
Exit 8 : Boggy Creek Road											
Eastbound On-Ramp	14,760	15,730	14,530	15,320	16,000	15,350	11,790	12,710	11,990	11,260	11,540
Westbound Off-Ramp	13,210	13,160	11,450	11,730	12,030	12,080	10,960	11,570	10,610	9,650	10,400
Exit 9 : Tradeport Drive / Conway Road											
Eastbound Off-Ramp	10,820	9,930	9,110	9,490	9,910	10,680	9,180	9,670	9,820	9,970	4,430
Westbound On-Ramp	6,020	5,370	6,070	6,480	6,860	7,480	5,690	7,020	7,160	7,300	3,590
Eastbound On-Ramp	3,200	3,200	2,820	2,730	2,550	2,730	2,730	2,790	3,230	3,660	4,020
Westbound Off-Ramp	2,750	2,660	2,220	2,315	2,120	1,960	2,420	2,240	2,410	2,580	2,940
Exit 11 : SR 436 (Semoran Boulevard)											
Eastbound Off-Ramp to NB SR 436	5,150	4,890	5,250	4,740	4,580	4,960	4,740	3,440	5,560	6,870	7,280
Eastbound Off-Ramp to SB SR 436	13,000	10,840	13,220	13,850	11,720	14,200	13,010	14,830	16,150	17,600	18,120
Westbound On-Ramp from NB SR 436	9,560	10,880	12,770	13,040	13,440	13,130	11,970	11,780	14,310	14,580	16,160
Westbound On-Ramp from SB SR 436	5,990	6,220	6,225	7,110	6,590	6,350	6,080	6,110	6,520	6,930	8,130
Eastbound On-Ramp from NB SR 436	7,700	8,450	9,000	7,840	7,670	7,580	7,860	7,560	9,220	9,290	10,380
Eastbound On-Ramp from SB SR 436	4,690	3,830	4,560	4,350	4,500	5,030	5,370	5,340	5,720	6,300	6,700
Westbound Off-Ramp to NB SR 436	5,560	4,520	4,880	5,030	5,440	5,750	5,680	5,960	6,470	6,930	7,020
Westbound Off-Ramp to SB SR 436	8,290	7,550	8,070	8,130	7,740	8,050	7,990	7,400	9,110	9,340	10,340
Exit 12 : Goldenrod Road											
Eastbound Off-Ramp	3,060	2,670	2,550	2,390	2,480	2,470	2,390	2,890	2,780	3,390	3,690
Westbound On-Ramp	1,760	2,140	1,640	1,650	1,590	1,630	1,990	2,070	2,030	2,560	2,760

Notes:

- SR 528 under construction in the Years 2007-2008 at the SR 436 Interchange.
- SR 528 under construction in the Years 2007-2008 at the Narcoossee Road Interchange.
- SR 528 under construction in the Years 2008 - 2009 at the Beachline Main Mainline Toll Plaza.
- \$.025 Toll Increase was applied systemwide at various locations in April 2009 and 2012.
- SR 528 under construction in the Years 2010-2012 at Dallas Boulevard and the new Dallas Mainline Toll Plaza.
- Systemwide Toll Increase was applied in July 2012 that included different toll rates for E-PASS and Cash customers.
- SR 528 under construction in the Year 2013 for bridge deck replacements at Tradeport Drive, Daetwyler Drive and Via Flora Drive.
- SR 528 under construction in the Year 2015 & 2016 widening and Airport Mainline Toll Plaza removal from Boggy Creek to SR 436.
- SR 528 and Innovation Way interchange / ICP interchange removal under construction 2017.



SR 528 (BEACHLINE EXPRESSWAY) Interchange - Ramp Volume Summary

Existing and Historical Average Annual Weekday Ramp Terminal Traffic Volumes

Ramp Location	Year 2007	Year 2008	Year 2009	Year 2010	Year 2011	Year 2012	Year 2013	Year 2014	Year 2015	Year 2016	Year 2017
Exit 12 : Goldenrod Road - Continued											
Westbound On-Ramp	650	510	510	640	580	620	560	670	810	830	850
Eastbound On-Ramp	3,190	2,910	3,420	2,890	2,920	3,130	3,250	3,450	3,700	4,870	5,370
Westbound Off-Ramp	2,930	2,700	2,705	2,690	2,740	2,900	2,990	3,110	3,160	4,200	4,560
Exit 13 : Narcoossee Road											
Eastbound Off-Ramp	10,050	9,830	9,010	8,980	9,470	10,690	10,840	11,280	11,610	13,140	14,000
Westbound On-Ramp	10,190	9,260	8,680	9,240	9,540	10,610	10,750	10,680	11,100	12,460	13,320
Eastbound On-Ramp	3,390	3,190	2,390	3,360	3,050	2,970	2,960	3,420	3,560	3,940	3,970
Westbound Off-Ramp	3,020	3,440	2,910	3,590	3,160	2,690	3,230	3,110	3,270	3,490	3,180
Exit 16 : SR 417 (Central Florida GreeneWay)											
Eastbound Off-Ramp to NB SR 417	15,050	14,460	13,650	13,570	13,060	13,410	12,750	13,960	13,800	15,700	17,190
Eastbound Off-Ramp to SB SR 417	260	250	350	900	870	800	950	1,220	1,410	1,820	2,380
Westbound On-Ramp from NB SR 417	520	730	860	990	940	1,030	1,150	1,560	1,610	1,820	2,200
Westbound On-Ramp from SB SR 417	15,750	15,420	15,030	13,500	12,550	13,660	12,740	13,450	13,950	15,340	16,690
Eastbound On-Ramp from NB SR 417	2,990	3,040	2,890	4,020	3,180	3,480	3,790	4,380	4,540	5,990	6,910
Eastbound On-Ramp from SB SR 417	5,670	5,360	4,980	6,030	4,490	5,500	5,180	5,720	5,980	6,700	6,670
Westbound Off-Ramp to NB SR 417	6,330	6,230	5,420	6,690	5,060	5,730	5,890	6,250	6,370	7,180	6,920
Westbound Off-Ramp to SB SR 417	3,720	3,270	2,930	4,440	3,260	3,590	3,860	4,420	5,020	6,000	6,740

Notes:

- SR 528 under construction in the Years 2007-2008 at the SR 436 Interchange.
- SR 528 under construction in the Years 2007-2008 at the Narcoossee Road Interchange.
- SR 528 under construction in the Years 2008 - 2009 at the Beachline Main Mainline Toll Plaza.
- \$0.25 Toll Increase was applied systemwide at various locations in April 2009 and 2012.
- SR 528 under construction in the Years 2010-2012 at Dallas Boulevard and the new Dallas Mainline Toll Plaza.
- Systemwide Toll Increase was applied in July 2012 that included different toll rates for E-PASS and Cash customers.
- SR 528 under construction in the Year 2013 for bridge deck replacements at Tradeport Drive, Daetwyler Drive and Via Flora Drive.
- SR 528 under construction in the Year 2015 & 2016 widening and Airport Mainline Toll Plaza removal from Boggy Creek to SR 436.
- SR 528 and Innovation Way interchange / ICP interchange removal under construction 2017.

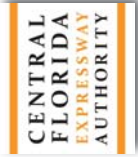

Existing and Historical Average Annual Weekday Ramp Terminal Traffic Volumes

Ramp Location	Year 2007	Year 2008	Year 2009	Year 2010	Year 2011	Year 2012	Year 2013	Year 2014	Year 2015	Year 2016	Year 2017
Exit 20 : Monument Parkway / Int'l Corp Park											
Eastbound Off-Ramp	1,450	1,400	1,220	2,670	2,780	3,710	4,020	4,740	4,830	4,920	5,700
Westbound On-Ramp	1,570	1,410	1,240	3,030	3,050	3,950	4,500	4,260	4,840	5,410	6,120
Eastbound On-Ramp	290	250	280	690	560	580	750	890	900	1,020	1,200
Westbound Off-Ramp	290	270	310	720	580	560	690	780	850	1,030	1,090
Exit 24 : Dallas Boulevard											
Eastbound Off-Ramp	1,840	2,030	1,600	1,890	1,600	1,620	1,870	1,950	1,970	2,610	2,690
Westbound On-Ramp	2,210	2,480	1,920	2,260	1,860	1,930	2,150	2,270	2,210	2,930	2,960
Exit 31 : SR 520											
Eastbound Off-Ramp	3,950	4,920	4,550	4,470	4,460	4,480	4,240	4,520	4,590	4,600	6,130
Westbound On-Ramp	3,010	5,430	3,910	3,930	3,820	3,920	3,730	3,610	3,820	3,820	5,220

Notes:

1. SR 528 under construction in the Years 2007-2008 at the SR 436 Interchange.
2. SR 528 under construction in the Years 2007-2008 at the Narcoossee Road Interchange.
3. SR 528 under construction in the Years 2008 - 2009 at the Beachline Main Mainline Toll Plaza.
4. \$0.25 Toll Increase was applied systemwide at various locations in April 2009 and 2012.
5. SR 528 under construction in the Years 2010-2012 at Dallas Boulevard and the new Dallas Mainline Toll Plaza.
6. Systemwide Toll Increase was applied in July 2012 that included different toll rates for E-PASS and Cash customers.
7. SR 528 under construction in the Year 2013 for bridge deck replacements at Tradeport Drive, Daetwyler Drive and Via Flora Drive.
8. SR 528 under construction in the Year 2015 & 2016 widening and Airport Mainline Toll Plaza removal from Boggy Creek to SR 436.
9. SR 528 and Innovation Way interchange / ICP interchange removal under construction 2017.

Central Florida GreeneWay



2017 Traffic Data and Statistics Manual
CENTRAL FLORIDA EXPRESSWAY AUTHORITY

Existing and Historical Average Annual Weekday Mainline Traffic Volumes

Location	Year 2007	Year 2008	Year 2009	Year 2010	Year 2011	Year 2012	Year 2013	Year 2014	Year 2015	Year 2016	Year 2017
International Drive to John Young Parkway	45,800	43,530	38,200	39,630	41,400	41,300	41,840	44,780	51,500	62,150	75,150
John Young Parkway to Orange Blossom Trail	45,205	43,000	37,205	37,620	40,400	40,610	41,850	45,940	53,210	64,650	79,200
Orange Blossom Trail to Florida Turnpike	43,260	40,610	35,085	36,450	37,300	38,170	39,850	44,260	51,780	63,880	78,840
Florida Turnpike to Landstar Boulevard	43,260	40,610	35,085	36,450	37,300	38,170	39,850	44,260	57,230	70,150	86,230
Landstar Boulevard to South Access (OIA)/Boggy Creek Road	44,800	40,390	35,900	36,520	38,300	38,350	40,300	44,880	54,580	66,700	76,520
South Access (OIA)/Boggy Creek Road to Lake Nona Boulevard	34,570	30,370	27,730	28,640	30,530	30,790	32,610	39,110	46,140	51,490	61,260
Lake Nona Boulevard to Narcoossee Road	34,130	29,860	27,220	28,290	29,990	29,930	33,500	38,020	44,980	53,040	61,070
Narcoossee Road to Moss Park Road	-----	-----	-----	31,510	30,670	30,940	35,250	40,480	48,510	57,750	65,750
Moss Park Road to Innovation Way/Dowden Road	-----	-----	-----	36,120	35,250	35,670	40,170	45,600	54,310	64,230	72,160
Innovation Way/Dowden Road to SR 528 (Beachline Expressway)	36,940	33,120	31,280	36,540	35,610	36,080	39,720	46,230	55,650	64,860	73,930
SR 528 (Beachline Expressway) to Lee Vista Boulevard	72,250	65,720	61,200	61,130	60,010	62,600	64,910	70,860	82,510	94,850	103,010
Lee Vista Boulevard to Curry Ford Road	76,100	68,900	63,300	63,160	62,530	64,950	66,575	73,770	86,030	97,280	104,190
Curry Ford Road to SR 408/SR 417 Systems Interchange	68,420	62,250	56,740	59,170	57,640	61,640	65,080	69,700	83,390	90,030	94,500
SR 408/SR 417 Systems Interchange to SR 50 (Colonial Dr)	87,350	79,430	74,150	76,570	76,980	74,720	73,840	76,920	89,760	98,570	103,480
SR 50 (Colonial Dr) to University Boulevard	82,800	75,550	70,500	72,900	74,900	-----	71,670	-----	86,650	95,670	100,740
University Boulevard to Orange / Seminole County Line	67,800	61,075	56,110	57,860	59,530	56,300	58,140	61,680	70,500	78,110	84,260

Notes:

- \$0.25 Toll Increase was applied systemwide at various locations in April 2009 and 2012.
- SR 417 under construction in the Year 2010-2011 from SR 528 to North of Curry Ford and from SR 408 to SR 50 (Colonial Drive).
- In the Year 2011, Valencia College Lane Southbound On and Off Ramps and Southbound 408/417 Spur were removed due to the new ramp alignment as part of the 408-253E-E1 project at the SR 408 System Interchange.
- In the Year 2012, Valencia College Lane Northbound On and Off Ramps and Northbound 408/417 Spur were removed due to the new ramp alignment as part of the 408-253E-E1 project at the SR 408 System Interchange.
- Systemwide Toll Increase was applied in July 2012 that included different toll rates for E-PASS and Cash customers.
- 24 Hour Machine counts were used for SR 417 NB Off-Ramp to Florida's Turnpike and SR 417 SB Off Ramp to Florida's Turnpike in 2017
- Exit 17A; South Access Rd opened in 2016
- Florida's Turnpike Southbound Off Ramp to Northbound Turnpike and SR 417 Northbound Off Ramps to Florida's Turnpike opened May 2016



SR 417 (CENTRAL FLORIDA GREENEWAY) Mainline Volume Summary

Existing and Historical Average Annual Weekday Ramp Terminal Traffic Volumes

Ramp Location	Year 2007	Year 2008	Year 2009	Year 2010	Year 2011	Year 2012	Year 2013	Year 2014	Year 2015	Year 2016	Year 2017
Exit 6 : International Drive											
Northbound On-Ramp	12,030	10,970	10,270	9,300	9,900	9,850	10,160	11,230	11,890	13,840	15,820
Southbound Off-Ramp	11,260	11,300	9,760	9,940	10,370	10,270	10,270	10,700	11,980	13,490	14,720
Exit 10 : John Young Parkway											
Northbound Off-Ramp	4,785	4,600	4,125	4,620	4,180	4,270	4,150	4,230	4,500	5,170	5,220
Southbound On-Ramp	4,860	4,490	4,120	4,500	4,250	4,020	4,010	4,060	4,260	4,626	4,950
Northbound On-Ramp	4,570	4,240	3,630	3,600	3,690	3,890	4,080	4,830	5,270	5,930	8,910
Southbound Off-Ramp	2,800	2,700	2,260	2,200	2,340	2,320	2,460	2,850	3,000	3,440	5,540
Southbound Off-Ramp to NB JYP	-----	-----	-----	-----	-----	-----	-----	-----	-----	-----	2,080
Southbound Off-Ramp to SB JYP	-----	-----	-----	-----	-----	-----	-----	-----	-----	-----	3,460
Exit 11 : US 17-92 / US 441											
Northbound Off-Ramp	3,910	4,200	3,630	3,810	4,030	3,840	3,930	4,250	4,520	5,210	5,080
Southbound On-Ramp	4,135	4,080	4,000	3,140	4,840	4,420	4,430	4,630	4,930	5,520	5,700
Northbound On-Ramp	2,810	2,780	2,610	2,710	2,700	2,740	3,070	3,350	3,690	4,160	5,570
Southbound Off-Ramp	3,290	3,110	2,900	3,070	3,070	3,080	3,400	3,870	4,210	4,810	4,950
Exit 12 : Florida Turnpike											
Northbound Off-Ramp to NB Turnpike	-----	-----	-----	-----	-----	-----	-----	-----	-----	-----	3,370
Northbound Off-Ramp to SB Turnpike	-----	-----	-----	-----	-----	-----	-----	-----	-----	-----	5,860
Northbound On-Ramp from NB Turnpike	-----	-----	-----	-----	-----	-----	-----	-----	3,120	4,030	7,110
Southbound Off-Ramp to NB Turnpike	-----	-----	-----	-----	-----	-----	-----	-----	-----	-----	6,150
Southbound Off-Ramp to SB Turnpike	-----	-----	-----	-----	-----	-----	-----	-----	2,580	3,330	4,200
Exit 14 : Landstar Boulevard											
Northbound Off-Ramp	3,590	4,340	2,720	2,730	2,910	3,010	3,210	3,750	5,500	6,520	7,550
Southbound On-Ramp	4,160	4,110	3,230	3,190	3,400	3,490	3,560	4,090	5,840	6,870	10,560
Northbound On-Ramp	4,400	4,010	3,745	2,770	3,700	3,380	3,540	3,940	3,980	4,130	4,070
Southbound Off-Ramp	4,890	4,220	3,020	3,220	3,610	3,300	3,560	3,990	4,140	4,510	4,200

Notes:

- \$0.25 Toll increase was applied systemwide at various locations in April 2009 and 2012.
- SR 417 under construction in the Year 2010-2011 from SR 528 to North of Curry Ford and from SR 408 to SR 50 (Colonial Drive).
- In the Year 2011, Valencia College Lane Southbound On and Off Ramps and Southbound 408/417 Spur were removed due to the new ramp alignment as part of the 408-253E-E1 project at the SR 408 System Interchange.
- In the Year 2012, Valencia College Lane Northbound On and Off Ramps and Northbound 408/417 Spur were removed due to the new ramp alignment as part of the 408-253E-E1 project at the SR 408 System Interchange.
- Systemwide Toll Increase was applied in July 2012 that included different toll rates for E-PASS and Cash customers.
- 24 Hour Machine counts were used for SR 417 NB Off-Ramp to Florida's Turnpike and SR 417 SB Off Ramp to Florida's Turnpike in 2017
- Exit 17A; South Access Rd opened in 2016
- Florida's Turnpike Southbound Off Ramp to Northbound Turnpike and SR 417 Northbound Off Ramps to Florida's Turnpike opened May 2016



SR 417 (CENTRAL FLORIDA GREENEWAY) Interchange - Ramp Volume Summary

Existing and Historical Average Annual Weekday Ramp Terminal Traffic Volumes

Ramp Location	Year 2007	Year 2008	Year 2009	Year 2010	Year 2011	Year 2012	Year 2013	Year 2014	Year 2015	Year 2016	Year 2017
Exit 17A : Int'l Airport (South Access Road)											
Northbound Off-Ramp	-----	-----	-----	-----	-----	-----	-----	-----	-----	8,490	9,540
Southbound On-Ramp	-----	-----	-----	-----	-----	-----	-----	-----	-----	9,180	9,450
Northbound On-Ramp	-----	-----	-----	-----	-----	-----	-----	-----	-----	590	1,030
Southbound Off-Ramp	-----	-----	-----	-----	-----	-----	-----	-----	-----	770	830
NB Ramp from Boggy Creek to South Access Rd)	-----	-----	-----	-----	-----	-----	-----	-----	-----	-----	10,440
SB Ramp from Boggy Creek to South Access Rd)	-----	-----	-----	-----	-----	-----	-----	-----	-----	-----	11,110
Exit 17B : Boggy Creek Road											
Northbound Off-Ramp	7,120	6,910	6,210	5,880	6,140	6,210	5,630	5,840	7,680	2,120	2,470
Southbound On-Ramp	7,790	7,680	6,440	6,860	6,990	6,950	6,670	6,610	8,390	2,070	3,940
Northbound On-Ramp	2,550	2,360	2,350	2,630	2,870	2,950	3,430	3,700	4,020	3,490	3,630
Southbound Off-Ramp	2,130	2,210	2,130	2,230	2,490	2,650	3,030	3,410	3,700	3,300	3,850
Exit 19 : Lake Nona Boulevard											
Northbound Off-Ramp	460	760	610	1,080	1,520	1,740	2,000	2,500	3,020	3,460	3,720
Southbound On-Ramp	430	510	640	1,080	1,470	1,770	1,870	2,460	2,880	3,120	3,570
Northbound On-Ramp	220	390	370	920	1,210	1,320	1,510	2,080	2,990	3,570	3,700
Southbound Off-Ramp	230	370	370	890	1,240	1,330	1,500	2,040	2,910	3,400	3,620
Exit 22 : Narcoossee Road											
Northbound Off-Ramp	4,020	3,850	3,250	3,580	3,090	3,120	3,400	3,920	3,960	4,260	5,660
Southbound On-Ramp	4,270	4,160	3,490	3,540	2,820	3,070	3,270	3,850	4,220	4,470	5,620
Northbound On-Ramp	5,530	6,060	5,860	3,360	3,410	3,710	4,420	5,400	6,140	6,840	7,740
Southbound Off-Ramp	5,570	5,210	4,940	3,420	3,180	3,490	4,140	5,000	5,600	6,440	7,610
Exit 23 : Moss Park Road											
Northbound Off-Ramp	-----	-----	-----	630	720	-----	770	840	940	1,100	1,340
Southbound On-Ramp	-----	-----	-----	580	660	-----	770	860	980	1,090	1,470
Northbound On-Ramp	-----	-----	-----	2,870	2,910	3,030	3,190	3,430	3,620	3,950	4,170
Southbound Off-Ramp	-----	-----	-----	2,950	3,050	3,260	3,220	3,470	3,830	4,320	4,800

Notes:

- \$0.25 Toll Increase was applied systemwide at various locations in April 2009 and 2012.
- SR 417 under construction in the Year 2010-2011 from SR 528 to North of Curry Ford and from SR 408 to SR 50 (Colonial Drive).
- In the Year 2011, Valencia College Lane Southbound On and Off Ramps and Southbound 408/417 Spur were removed due to the new ramp alignment as part of the 408-253E-E1 project at the SR 408 System Interchange.
- In the Year 2012, Valencia College Lane Northbound On and Off Ramps and Northbound 408/417 Spur were removed due to the new ramp alignment as part of the 408-253E-E1 project at the SR 408 System Interchange.
- Systemwide Toll Increase was applied in July 2012 that included different toll rates for E-PASS and Cash customers.
- 24 Hour Machine counts were used for SR 417 NB Off-Ramp to Florida's Turnpike and SR 417 SB Off Ramp to Florida's Turnpike in 2017
- Exit 17A, South Access Rd opened in 2016
- Florida's Turnpike Southbound Off Ramp to Northbound Turnpike and SR 417 Northbound Off Ramps to Florida's Turnpike opened May 2016



SR 417 (CENTRAL FLORIDA GREENEWAY) Interchange - Ramp Volume Summary

Existing and Historical Average Annual Weekday Ramp Terminal Traffic Volumes

Ramp Location	Year 2007	Year 2008	Year 2009	Year 2010	Year 2011	Year 2012	Year 2013	Year 2014	Year 2015	Year 2016	Year 2017
Exit 24 : Dowden Road											
Northbound Off-Ramp	-----	-----	-----	-----	70	100	230	300	480	710	885
Southbound On-Ramp	-----	-----	-----	-----	70	90	200	360	590	890	1,130
Northbound On-Ramp	-----	-----	-----	-----	240	220	340	670	950	1,280	1,500
Southbound Off-Ramp	-----	-----	-----	-----	320	330	500	810	1,180	1,650	2,020
Exit 26 : Beachline Expressway (SR 528)											
Northbound Off-Ramp to EB SR 528	2,990	3,040	2,890	4,020	3,180	3,480	3,790	4,380	4,540	5,990	6,910
Northbound Off-Ramp to WB SR 528	520	730	860	990	940	1,030	1,150	1,560	1,610	1,820	2,200
Southbound On-Ramp from EB SR 528	260	250	350	900	870	800	950	1,220	1,410	1,820	2,380
Southbound On-Ramp from WB SR 528	3,720	3,270	2,930	4,440	3,260	3,590	3,860	4,420	5,020	6,000	6,740
Northbound On-Ramp from EB SR 528	15,050	14,660	13,650	13,570	13,060	13,410	12,750	13,960	13,800	15,700	17,190
Northbound On-Ramp from WB SR 528	6,330	6,230	5,420	6,690	5,060	5,730	5,890	6,250	6,370	7,180	6,920
Southbound Off-Ramp to EB SR 528	5,670	5,360	4,980	6,030	4,490	5,500	5,180	5,720	5,980	6,700	6,670
Southbound Off-Ramp to WB SR 528	15,750	15,420	15,030	13,500	12,550	13,660	12,740	13,450	13,950	15,340	16,690
Exit 27 : Lee Vista Boulevard											
Northbound Off-Ramp	1,390	1,300	1,120	1,160	1,070	1,140	1,180	1,440	1,580	2,020	2,260
Southbound On-Ramp	1,400	1,300	1,250	1,410	1,270	1,280	1,270	1,670	1,860	2,160	2,340
Northbound On-Ramp	3,300	2,980	2,300	2,330	2,380	2,460	2,490	2,640	2,680	3,050	4,320
Southbound Off-Ramp	3,340	2,800	2,170	2,270	2,480	2,310	2,420	2,620	2,680	3,030	3,020
Exit 30 : Curry Ford Road											
Northbound Off-Ramp	8,140	7,680	6,830	5,900	5,940	5,690	5,530	6,230	7,100	8,940	9,290
Southbound On-Ramp	8,220	7,270	7,170	5,900	6,380	6,070	5,130	5,490	5,890	6,820	7,770
Northbound On-Ramp	4,510	4,330	3,840	4,070	3,940	4,380	4,170	4,440	4,650	4,860	4,720
Southbound Off-Ramp	4,170	3,970	3,600	3,740	3,490	4,070	3,820	4,230	4,520	4,810	4,610

Notes:

- \$0.25 Toll Increase was applied systemwide at various locations in April 2009 and 2012.
- SR 417 under construction in the Year 2010-2011 from SR 528 to North of Curry Ford and from SR 408 to SR 50 (Colonial Drive).
- In the Year 2011, Valencia College Lane Southbound On and Off Ramps and Southbound 408/417 Spur were removed due to the new ramp alignment as part of the 408-253E-E1 project at the SR 408 System Interchange.
- In the Year 2012, Valencia College Lane Northbound On and Off Ramps and Northbound 408/417 Spur were removed due to the new ramp alignment as part of the 408-253E-E1 project at the SR 408 System Interchange.
- Systemwide Toll Increase was applied in July 2012 that included different toll rates for E-PASS and Cash customers.
- 24 Hour Machine counts were used for SR 417 NB Off-Ramp to Florida's Turnpike and SR 417 SB Off Ramp to Florida's Turnpike in 2017
- Exit 17A; South Access Rd opened in 2016
- Florida's Turnpike Southbound Off Ramp to Northbound Turnpike and SR 417 Northbound Off Ramps to Florida's Turnpike opened May 2016



SR 417 (CENTRAL FLORIDA GREENEWAY) Interchange - Ramp Volume Summary

Existing and Historical Average Annual Weekday Ramp Terminal Traffic Volumes

Ramp Location	Year 2007	Year 2008	Year 2009	Year 2010	Year 2011	Year 2012	Year 2013	Year 2014	Year 2015	Year 2016	Year 2017
Exit 33A&B : SR 408 (East-West Expressway)											
Northbound Off-Ramp to EB SR 408	7,530	7,210	6,080	6,220	6,230	6,340	6,040	6,030	7,230	7,660	8,180
Northbound Off-Ramp to WB SR 408	7,770	6,920	7,100	7,530	8,050	8,170	8,190	8,180	10,520	11,910	11,350
Southbound On-Ramp from EB SR 408	7,200	6,400	6,700	7,080	6,950	7,310	7,530	8,620	9,880	11,040	10,690
Southbound On-Ramp from WB SR 408	7,680	6,980	6,520	6,380	6,250	6,850	5,830	6,210	7,130	7,780	8,550
Northbound On-Ramp from WB SR 408	4,580	4,130	3,975	4,220	4,020	3,410	3,590	3,870	4,250	4,770	4,960
Southbound Off-Ramp to EB SR 408	4,430	5,960	3,645	3,620	3,900	3,480	3,430	3,740	4,000	4,590	4,400
Northbound On-Ramp from EB SR 408	-----	-----	-----	-----	-----	15,090	15,450	16,160	17,540	18,470	18,730
Southbound Off-Ramp to WB SR 408	-----	-----	-----	-----	15,980	15,290	15,590	15,980	17,030	18,080	18,450
Exit 34 : SR 50 (East Colonial Drive)											
Northbound Off-Ramp	5,240	4,770	3,920	4,140	3,740	4,110	3,840	4,170	4,810	5,120	4,980
Southbound On-Ramp	4,430	3,910	3,190	3,330	3,370	3,550	3,480	3,730	4,250	4,600	4,810
Northbound On-Ramp	2,550	2,450	1,760	1,880	2,070	2,870	2,670	2,950	3,300	3,520	3,650
Southbound Off-Ramp	2,570	2,350	1,700	1,920	2,960	2,820	2,640	2,980	3,290	3,470	3,530
Exit 37 : University Boulevard											
Northbound Off-Ramp to EB University Blvd	10,000	9,475	8,950	9,030	9,610	8,280	7,550	9,560	9,920	10,270	10,340
Northbound Off Ramp to WB University Blvd	2,590	2,350	2,050	2,060	2,010	2,020	1,780	2,060	2,200	2,440	2,522
Northbound E-PASS Ramp to University Blvd Exit	-----	-----	-----	-----	-----	-----	-----	-----	-----	-----	9,860
Southbound On-Ramp from EB University Blvd	2,600	2,380	2,490	2,390	1,980	1,970	2,130	2,390	2,800	3,840	3,154
Southbound On Ramp from EB University Blvd	9,020	8,330	8,090	8,720	8,970	8,570	8,270	8,710	9,240	9,900	9,983
Northbound On-Ramp	4,520	3,950	3,550	3,500	3,520	3,410	3,300	3,430	3,710	3,990	4,227
Southbound Off-Ramp	4,520	3,950	3,550	3,500	3,520	3,410	3,300	3,430	3,710	3,990	3,937

Notes:

1. \$.05 Toll Increase was applied systemwide at various locations in April 2009 and 2012.
2. SR 417 under construction in the Year 2010-2011 from SR 528 to North of Curry Ford and from SR 408 to SR 50 (Colonial Drive).
3. In the Year 2011, Valencia College Lane Southbound On and Off Ramps and Southbound 408/417 Spur were removed due to the new ramp alignment as part of the 408-253E-E1 project at the SR 408 System Interchange.
4. In the Year 2012, Valencia College Lane Northbound On and Off Ramps and Northbound 408/417 Spur were removed due to the new ramp alignment as part of the 408-253E-E1 project at the SR 408 System Interchange.
5. Systemwide Toll Increase was applied in July 2012 that included different toll rates for E-PASS and Cash customers.
6. 24 Hour Machine counts were used for SR 417 NB Off-Ramp to Florida's Turnpike and SR 417 SB Off Ramp to Florida's Turnpike in 2017
7. Exit 17A; South Access Rd opened in 2016
8. Florida's Turnpike Southbound Off Ramp to Northbound Turnpike and SR 417 Northbound Off Ramps to Florida's Turnpike opened May 2016



SR 417 (CENTRAL FLORIDA GREENEWAY) Interchange - Ramp Volume Summary

Western Beltway and Wekiva Parkway



Existing and Historical Average Annual Weekday Mainline Traffic Volumes

Location	Year 2007	Year 2008	Year 2009	Year 2010	Year 2011	Year 2012	Year 2013	Year 2014	Year 2015	Year 2016	Year 2017
Seidel Road to Schofield Road	13,180	12,820	11,950	13,070	13,290	14,880	15,600	17,510	22,950	26,790	31,920
Schofield Road to New Independence Parkway	-----	-----	-----	-----	-----	-----	-----	-----	23,580	27,760	34,580
New Independence Parkway to CR 535	14,000	13,540	12,500	13,700	14,130	15,930	16,620	19,520	26,200	31,570	40,570
CR 535 to Florida Turnpike / SR 50	34,090	34,010	32,510	34,250	34,820	35,740	37,630	41,940	50,770	58,240	65,550
Florida Turnpike / SR 50 to SR 438	41,650	37,350	36,330	38,470	39,440	40,260	43,480	48,290	57,450	65,850	73,100
SR 438 / Plant St / Franklin St to West Road	36,400	32,660	31,930	33,720	34,360	35,840	38,760	43,860	52,620	60,860	67,530
West Road to Ocoee Apopka Road (CR 437A)	30,410	26,990	27,600	29,500	29,600	31,650	34,430	38,930	46,360	53,510	58,710
Ocoee Apopka Road (CR 437A) to SR 414	27,610	24,440	20,500	20,680	20,110	29,320	33,220	37,440	44,190	50,580	55,370
SR 429/414 (SR 414 to West US 441)	-----	-----	-----	-----	-----	-----	18,670	21,320	24,470	28,490	29,910
West US 441 to Kelly Park Rd (Wekiva Parkway)	-----	-----	-----	-----	-----	-----	-----	-----	-----	-----	8,930

Notes:

1. \$.0.25 Toll Increase was applied systemwide at various locations in April 2009 and 2012.
2. SR 429 & 414 interchange was under construction during the Year 2011 and Year 2012.
3. Systemwide Toll Increase was applied in July 2012 that included different toll rates for E-PASS and Cash customers.
4. The SR 429/414 Extension opened to traffic in January 2013. At the same time, the existing north portion of SR 429 from SR 414 to US 441 was re-named SR 451.
5. CR 437A Northbound On and Southbound Off ramps opened to traffic in January 2013.
6. Schofield Road interchange opened to traffic in 2015.
7. Wekiva Parkway from SR 429 Connector Road to Kelly Park Road opened in July 2017



Existing and Historical Average Annual Weekday Ramp Terminal Traffic Volumes

Ramp Location	Year 2007	Year 2008	Year 2009	Year 2010	Year 2011	Year 2012	Year 2013	Year 2014	Year 2015	Year 2016	Year 2017
Exit 13 : Schofield Road											
Northbound Off-Ramp	-----	-----	-----	-----	-----	-----	-----	-----	-----	190	430
Southbound On-Ramp	-----	-----	-----	-----	-----	-----	-----	-----	-----	290	220
Northbound On-Ramp from WB Schofield Rd	-----	-----	-----	-----	-----	-----	-----	-----	-----	820	1,890
Northbound On-Ramp from EB Schofield Rd	-----	-----	-----	-----	-----	-----	-----	-----	-----	-----	1,450
Southbound Off-Ramp	-----	-----	-----	-----	-----	-----	-----	-----	-----	680	1,510
Exit 15 : New Independence Pkwy											
Northbound Off-Ramp	470	500	420	390	370	370	530	780	980	1,020	1,290
Southbound On-Ramp	500	510	430	380	400	400	490	790	1,030	1,110	1,420
Northbound On-Ramp	950	890	720	700	820	920	1,180	1,880	2,410	3,000	4,550
Southbound Off-Ramp	840	840	680	700	790	900	1,140	1,790	2,290	2,820	4,190
Exit 19 : CR 535											
Northbound Off-Ramp	1,440	1,390	1,350	1,430	1,550	1,790	1,740	2,000	2,520	2,990	3,410
Southbound On-Ramp	1,450	1,440	1,340	1,390	1,570	1,650	1,750	1,910	2,370	2,750	3,400
Northbound On-Ramp	11,740	11,880	11,440	11,760	11,980	11,710	12,030	12,820	14,090	15,720	15,350
Southbound Off-Ramp	11,240	11,420	11,260	11,610	11,830	11,540	12,060	12,810	14,170	15,790	15,630
Exits 22 & 23 : FL Turnpike / SR 50											
Northbound On-Ramp from SR 50	2,450	2,610	2,580	2,610	2,540	2,750	2,750	2,970	3,480	3,800	3,460
Southbound Off-Ramp to SR 50	3,000	2,670	2,740	2,680	2,430	2,690	2,810	3,170	3,500	3,650	3,970
Northbound Off-Ramp to NB Turnpike	1,580	1,270	1,370	1,760	1,600	1,530	1,840	1,850	2,680	2,890	3,530
Northbound Off-Ramp to SB Turnpike	7,670	8,660	8,130	8,260	8,790	8,450	9,040	9,900	11,900	13,430	14,730
Southbound On-Ramp from NB Turnpike	8,360	7,980	7,700	7,850	8,240	7,920	7,830	8,530	10,110	12,010	12,880
Southbound On-Ramp from SB Turnpike	1,675	1,620	1,680	1,660	1,740	1,920	2,190	2,310	3,150	3,200	3,900

Notes:

- \$0.25 Toll Increase was applied systemwide at various locations in April 2009 and 2012.
- SR 429 & 414 interchange was under construction during the Year 2011 and Year 2012.
- Systemwide Toll Increase was applied in July 2012 that included different toll rates for E-PASS and Cash customers.
- The SR 429/414 Extension opened to traffic in January 2013. At the same time, the existing north portion of SR 429 from SR 414 to US 441 was re-named SR 451.
- CR 437A Northbound On and Southbound Off ramps opened to traffic in January 2013.
- Schofield Road interchange opened to traffic in 2015.
- Wekiva Parkway from SR 429 Connector Road to Kelly Park Road opened in July 2017

Existing and Historical Average Annual Weekday Ramp Terminal Traffic Volumes

Ramp Location	Year 2007	Year 2008	Year 2009	Year 2010	Year 2011	Year 2012	Year 2013	Year 2014	Year 2015	Year 2016	Year 2017
Exits 22 & 23 : FL Turnpike / SR 50 (Cont.)											
Northbound Off-Ramp to SR 50	2,665	2,330	2,320	2,690	2,190	1,990	1,780	1,900	2,450	2,400	2,380
Southbound On-Ramp from SR 50	2,870	2,480	3,150	2,810	2,380	2,170	2,750	2,100	2,680	2,580	2,440
Northbound On-Ramp from NB Turnpike	10,640	9,630	9,000	9,200	9,340	9,200	9,630	10,410	12,060	14,240	15,820
Northbound On-Ramp from SB Turnpike	3,080	2,680	2,670	3,060	3,040	3,190	3,280	3,680	4,640	5,440	5,350
Southbound Off-Ramp to NB Turnpike	2,880	2,520	2,500	2,990	3,000	3,140	3,130	3,390	4,160	4,770	5,270
Southbound Off-Ramp to SB Turnpike	9,910	9,440	8,680	8,710	9,210	9,270	7,910	8,530	10,120	11,160	12,190
Exit 24 : SR 438 / Plant Street											
Northbound Off-Ramp	4,340	4,130	3,830	4,050	4,010	3,640	3,810	4,150	4,710	5,450	5,650
Southbound On-Ramp	3,640	3,510	3,200	3,420	3,590	3,280	3,550	3,750	4,280	4,740	5,000
Northbound On-Ramp	1,480	1,550	1,200	1,270	1,290	1,110	1,470	1,640	2,000	2,170	2,340
Southbound Off-Ramp	1,670	1,400	1,430	1,450	1,230	1,390	1,500	1,680	1,900	2,040	2,610
Exit 26 : West Road											
Northbound Off-Ramp	3,550	3,410	2,630	2,590	2,640	2,590	2,740	3,260	3,860	4,760	5,410
Southbound On-Ramp	3,530	3,360	2,720	2,700	2,980	2,730	2,790	3,270	3,870	4,690	5,380
Northbound On-Ramp	510	560	520	540	420	530	620	800	810	950	1,020
Southbound Off-Ramp	580	540	500	530	440	600	570	720	730	840	1,010
Exit 29 : CR 437A (Ocoee Apopka Road)											
Northbound Off-Ramp	1,420	1,300	3,510	4,450	4,880	1,170	1,230	1,420	1,700	1,960	2,520
Southbound On-Ramp	1,380	1,250	3,590	4,370	4,610	1,160	1,200	1,420	1,800	1,990	2,610
Northbound On-Ramp	-----	-----	-----	-----	-----	-----	500	570	680	740	900
Southbound Off-Ramp	-----	-----	-----	-----	-----	-----	450	500	780	820	800

Notes:

- \$0.25 Toll Increase was applied systemwide at various locations in April 2009 and 2012.
- SR 429 & 414 interchange was under construction during the Year 2011 and Year 2012.
- Systemwide Toll Increase was applied in July 2012 that included different toll rates for E-PASS and Cash customers.
- The SR 429/414 Extension opened to traffic in January 2013. At the same time, the existing north portion of SR 414 to US 441 was re-named SR 451.
- CR 437A Northbound On and Southbound Off ramps opened to traffic in January 2013.
- Schofield Road interchange opened to traffic in 2015.
- Wekiva Parkway from SR 429 Connector Road to Kelly Park Road opened in July 2017

Existing and Historical Average Annual Weekday Ramp Terminal Traffic Volumes

Ramp Location	Year 2007	Year 2008	Year 2009	Year 2010	Year 2011	Year 2012	Year 2013	Year 2014	Year 2015	Year 2016	Year 2017
Exit 30 : SR 414 (Apopka Expressway)											
Northbound Off-Ramp to SR 414/451	-----	-----	-----	-----	-----	5,030	6,040	7,220	8,950	10,620	10,470
Northbound Off-Ramp to EB SR 414	-----	-----	-----	-----	-----	-----	-----	-----	5,090	5,740	6,940
Northbound Off-Ramp to NB SR 451	-----	-----	-----	-----	-----	4,960	5,700	6,920	8,130	9,990	9,640
Southbound On-Ramp from WB SR 414	-----	-----	-----	-----	-----	-----	-----	-----	6,190	6,500	7,720
Northbound On-Ramp from WB SR 414	-----	-----	-----	-----	-----	-----	3,050	3,410	3,950	4,700	4,290
Southbound Off-Ramp to EB SR 414	-----	-----	-----	-----	-----	-----	3,080	3,510	3,990	4,630	4,210
Exit 34 : SR 429 Connector Road (US 441/CR 437)											
Northbound Off-Ramp	-----	-----	-----	-----	-----	-----	9,330	10,950	12,420	14,310	10,260
Southbound On-Ramp	-----	-----	-----	-----	-----	-----	9,570	10,850	12,050	14,180	12,870
Northbound On-Ramp	-----	-----	-----	-----	-----	-----	-----	-----	-----	-----	170
Southbound Off-Ramp	-----	-----	-----	-----	-----	-----	-----	-----	-----	-----	300
Exit 38: Kelly Park Road											
Northbound Off-Ramp	-----	-----	-----	-----	-----	-----	-----	-----	-----	-----	4,720
Southbound On-Ramp	-----	-----	-----	-----	-----	-----	-----	-----	-----	-----	4,210

Notes:

- \$0.25 Toll Increase was applied systemwide at various locations in April 2009 and 2012.
- SR 429 & 414 interchange was under construction during the Year 2011 and Year 2012.
- Systemwide Toll Increase was applied in July 2012 that included different toll rates for E-PASS and Cash customers.
- The SR 429/414 Extension opened to traffic in January 2013. At the same time, the existing north portion of SR 414 to US 441 was re-named SR 451.
- CR 437A Northbound On and Southbound Off ramps opened to traffic in January 2013.
- Schofield Road interchange opened to traffic in 2015.
- Wekiva Parkway from SR 429 Connector Road to Kelly Park Road opened in July 2017

Apopka Expressway



Existing and Historical Average Annual Weekday Mainline Traffic Volumes

Location	Year 2009	Year 2010	Year 2011	Year 2012	Year 2013	Year 2014	Year 2015	Year 2016	Year 2017
SR 451 / SR 429 to Marden Road	10,500	13,025	13,820	16,320	20,870	24,120	29,100	33,900	36,790
Marden Road to Keene Road	-----	-----	-----	-----	-----	-----	-----	-----	36,500
Keene Road to Hiawassee Road	12,400	16,075	17,580	20,590	24,670	28,290	33,500	38,600	41,870
Hiawassee Road to US 441 (Orange Blossom Trail)	13,780	18,205	20,080	21,990	25,900	28,810	34,200	38,700	41,110
US 441 (Orange Blossom Trail) to Rose Ave/Bear Lake Rd	27,340	31,075	32,240	34,040	35,290	37,790	42,400	44,300	45,080

Notes:

1. SR 414 Apopka Expressway Partially Opened to traffic in February 2009, fully opened to traffic in May 2009.
2. SR 429 & 414 interchange was under construction during the Year 2011 and Year 2012.
3. Systemwide Toll Increase was applied in July 2012 that included different toll rates for E-PASS and Cash customers.
4. The SR 429/414 Extension, which extended SR 414 to the west of SR 451 opened to traffic in January 2013.
5. The Marden Road interchange opened to traffic in June of 2017.



Existing and Historical Average Annual Weekday Ramp Terminal Traffic Volumes

Ramp Location	Year 2009	Year 2010	Year 2011	Year 2012	Year 2013	Year 2014	Year 2015	Year 2016	Year 2017
Exit 4B : SR 429 (Western Beltway)									
Eastbound On-Ramp from NB SR 429	-----	-----	-----	5,030	6,040	7,220	8,950	10,620	10,470
Westbound Off-Ramp to SB SR 429	-----	-----	-----	4,960	5,700	6,920	8,130	9,990	9,640
Eastbound On-Ramp from SB SR 429/414	-----	-----	-----	-----	3,080	3,510	3,990	4,630	4,210
Westbound Off-Ramp to NB SR 429/414	-----	-----	-----	-----	3,050	3,410	3,950	4,700	4,290
Exit 4A : SR 451									
Eastbound On-Ramp from SR 451 SB	2,390	2,900	3,420	3,710	1,600	1,310	1,550	1,600	2,410
Westbound Off-Ramp to SR 451 NB	2,190	2,830	3,140	3,030	1,410	1,550	1,730	1,960	2,000
Eastbound Off-Ramp to SR 451 NB	-----	-----	-----	-----	-----	-----	5,090	5,740	6,970
Westbound On Ramp from SR 451 SB	-----	-----	-----	-----	-----	-----	6,190	6,500	7,760
Exit 5 : Marden Road									
Eastbound On-Ramp	-----	-----	-----	-----	-----	-----	-----	-----	680
Westbound Off-Ramp	-----	-----	-----	-----	-----	-----	-----	-----	580
Exit 6 : Keene Road									
Eastbound On-Ramp	960	1,520	1,910	2,220	2,100	2,090	2,260	2,400	2,620
Westbound Off-Ramp	940	1,530	1,850	2,050	1,920	1,967	2,140	2,290	2,550
Exit 8 : Hiwassee Road									
Eastbound Off-Ramp	910	1,010	1,130	1,550	1,600	1,840	2,280	2,550	2,810
Westbound On-Ramp	890	1,100	1,090	1,430	1,600	1,970	2,430	2,790	2,780
Eastbound On-Ramp	1,550	2,100	2,350	2,220	2,210	2,250	2,530	2,490	2,460
Westbound Off-Ramp	1,630	2,140	2,370	2,160	2,210	2,450	2,630	2,620	2,490
Exit 9 : US 441 (Orange Blossom Trail)									
Eastbound Off-Ramp	1,190	1,460	1,610	1,940	2,130	2,430	2,980	3,780	4,260
Westbound On-Ramp from NB US 441	835	1,085	1,070	1,320	1,420	1,660	2,050	2,560	2,910
Westbound On-Ramp from SB US 441	165	215	210	280	390	390	430	550	610
Eastbound On-Ramp	7,000	7,130	6,920	6,940	5,870	5,660	5,770	5,270	5,020
Westbound Off-Ramp	8,750	8,500	8,130	8,650	7,600	7,720	7,900	7,280	6,770

Notes:

- SR 414 Apopka Expressway Partially Opened to traffic in February 2009, fully opened to traffic in May 2009.
- SR 429 & 414 interchange was under construction during the year 2011 and year 2012.
- Systemwide Toll Increase was applied in July 2012 that included different toll rates for E-PASS and Cash customers.
- The SR 429/414 Extension, which extended SR 414 to the west of SR 451 opened to traffic in January 2013.
- The Marden Road interchange opened to traffic in June of 2017.

Western Beltway Connector Road



Existing and Historical Average Annual Weekday Mainline Traffic Volumes

Segment Location	Year 2007	Year 2008	Year 2009	Year 2010	Year 2011	Year 2012	Year 2013	Year 2014	Year 2015	Year 2016	Year 2017
SR 414 (Apopka Expressway) to US 441	24,440	25,080	26,410	26,410	26,670	26,070	12,250	12,820	14,560	15,800	17,300

Notes:

1. \$.0.25 Toll Increase was applied systemwide at various locations in April 2009 and 2012.
2. SR 429 & 414 interchange was under construction during the Year 2011 and Year 2012.
3. Systemwide Toll Increase was applied in July 2012 that included different toll rates for E-PASS and Cash customers.
4. The SR 429/414 Extension opened to traffic in January 2013. The existing portion of SR 429 from SR 414 to US 441 was re-named SR 451.



Existing and Historical Average Annual Weekday Ramp Terminal Traffic Volumes

Ramp Location	Year 2007	Year 2008	Year 2009	Year 2010	Year 2011	Year 2012	Year 2013	Year 2014	Year 2015	Year 2016	Year 2017
Exit To & From SR 414 and SR 429											
Northbound On-Ramp from NB SR 429	-----	-----	-----	-----	-----	9,415	4,130	4,570	5,090	5,740	6,910
Southbound Off-Ramp to SB SR 429	-----	-----	-----	-----	-----	10,120	5,090	5,330	6,190	6,500	7,680
Northbound On-Ramp from WB SR 414	-----	-----	2,190	2,830	3,140	2,825	1,410	1,550	1,730	1,960	2,000
Southbound Off-Ramp to EB SR 414	-----	-----	2,390	2,900	3,420	3,710	1,600	1,310	1,550	1,600	1,870
Expressway Ends : US 441 & Vick Road											
Northbound Off-Ramp	14,220	12,080	12,685	12,980	13,110	12,240	5,660	5,960	6,820	7,700	8,890
Southbound On-Ramp from SB US 441	6,350	7,720	8,245	9,150	9,250	9,960	2,760	2,660	2,840	2,930	3,170
Southbound On-Ramp from NB US 441/Vick Rd	7,040	4,640	4,150	4,280	4,310	3,870	3,840	4,260	4,900	5,170	6,400

Notes:

- \$0.25 Toll Increase was applied systemwide at various locations in April 2009 and 2012.
- SR 429 & 414 interchange was under construction during the Year 2011 and Year 2012.
- Systemwide Toll Increase was applied in July 2012 that included different toll rates for E-PASS and Cash customers.
- The SR 429/414 Extension opened to traffic in January 2013. The existing portion of SR 429 from SR 414 to US 441 was re-named SR 451.

Systemwide Adjustment Factors

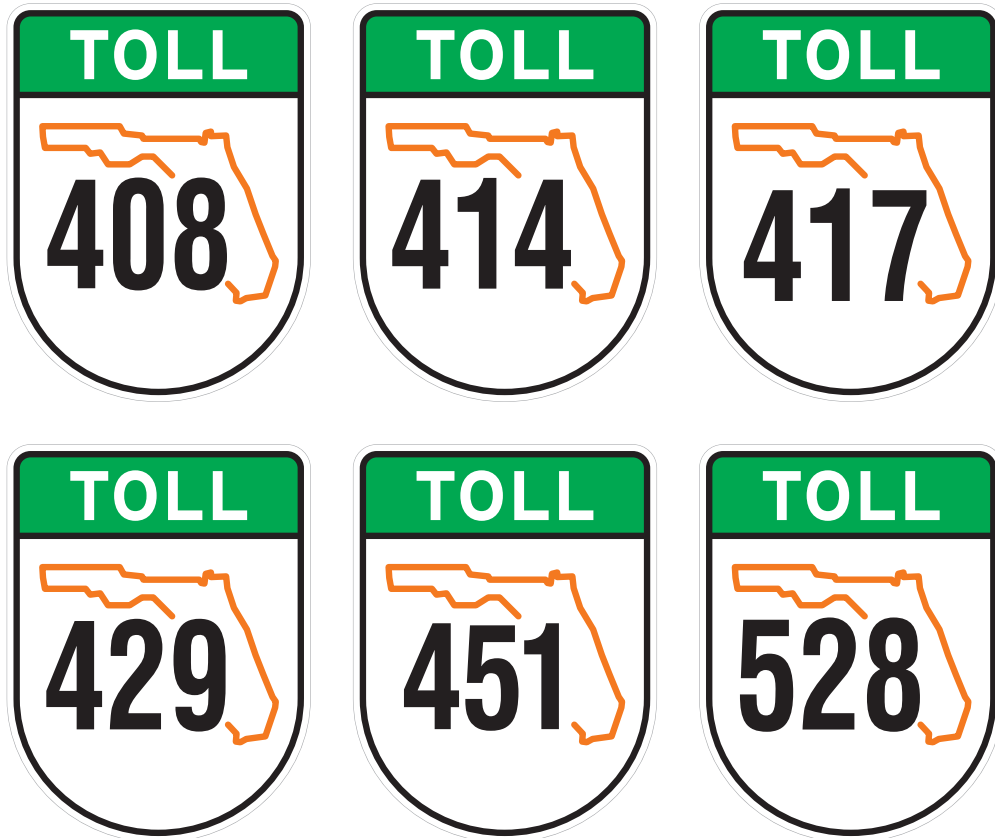

Weekday, Daily and Monthly Adjustment Factors

Annual Average Weekday Traffic (AAWT) is the estimated volume of traffic on a highway and/or expressway segment for five (5) days of the week (Monday through Friday) that is obtained from collecting 24 hour, 72 hour traffic counts and/or monthly traffic counts and adjusting these collected weekday traffic counts by utilizing the developed daily and monthly seasonal adjustment factors.

All weekday traffic volumes collected must be adjusted to reflect the seasonal changes in traffic volumes. In order to calculate the AAWT and AADT, monthly seasonal adjustment factors are calculated from each of the mainline toll plaza transactions for each month of the year. These numbers are then used to convert the twenty-four hour Weekday Traffic Counts to AAWT.

In addition to developing the AAWT, seasonal adjustment factors and a conversion factor to calculate the Average Annual Daily Traffic (AADT) are also tabulated. The AADT is the estimated daily traffic volume on a highway and/or expressway for all days of the week, (Monday through Sunday) over the period of one year. The AADT is obtained by taking similar adjustment factors developed from the mainline and ramp toll plaza transactions and applying those factors to the same twenty-four hour weekday traffic counts. This calculated conversion factor is used to convert the AAWT to AADT by multiplying the appropriate factor to the corresponding AAWT to obtain the AADT traffic volume.

The following tables summarize the daily and monthly adjustment factors for the Central Florida Expressway Authority's expressway system. Note that these adjustment factors are based on the year 2017 mainline toll plaza transactions and accounts for the number of weekdays, weekends and holidays occurring each month.

Average Annual Weekday Traffic (AAWT)

Monthly Seasonal Conversion Factors

CFX Expressway System	AAWT Monthly Conversion Factors					
	January	February	March	April	May	June
SR 408 (East-West Expressway)						
Florida Turnpike (SR 91) to Interstate 4 (I-4)	1.0599	1.0070	0.9916	0.9864	0.9876	1.0194
Interstate 4 (I-4) to SR 50 (East Colonial Drive)	1.0420	0.9936	0.9940	0.9949	1.0073	1.0244
SR 528 (Beachline Expressway)						
Boggy Creek Road to SR 417 (Central Florida GreeneWay)	1.0556	0.9958	0.9458	0.9860	0.9899	1.0034
SR 417 (Central Florida GreeneWay) to SR 520	1.1104	1.0490	0.9344	0.9867	0.9897	0.9951
SR 417 (Central Florida GreeneWay)						
International Drive to SR 528 (Beachline Expressway)	1.1401	1.0552	0.9886	1.0022	1.0275	1.0234
SR 528 (Beachline Expressway) to Orange/Seminole County Line	1.1003	1.0330	1.0050	0.9971	0.9980	1.0162
SR 429 (Western Beltway and Wekiva Parkway)						
Seidel Road to CR 535 (Old Winter Garden Road)	1.1089	1.0598	0.9965	1.0053	1.0119	1.0048
CR 535 (Old Winter Garden Road to US 441 (Orange Blossom Trail))	1.1070	1.0466	1.0161	1.0113	1.0065	1.0140
SR 414 (Apopka Expressway)						
SR 429 / SR 451 to US 441 (Orange Blossom Trail)	0.8167	1.0578	1.0336	1.0278	1.0279	1.0401
SR 451 (Western Beltway Connector Road)						
SR 429 / SR 451 to US 441 (Orange Blossom Trail)	0.9619	1.0522	1.0249	1.0196	1.0172	1.0271

CFX Expressway System	AAWT Monthly Conversion Factor					
	July	August	September	October	November	December
SR 408 (East-West Expressway)						
Florida Turnpike (SR 91) to Interstate 4 (I-4)	1.0299	1.0212	0.9937	0.9732	0.9648	0.9720
Interstate 4 (I-4) to SR 50 (East Colonial Drive)	1.0310	1.0282	0.9844	0.9606	0.9675	0.9777
SR 528 (Beachline Expressway)						
Boggy Creek Road to SR 417 (Central Florida GreeneWay)	1.0012	1.0437	1.0609	1.0005	0.9787	0.9533
SR 417 (Central Florida GreeneWay) to SR 520	0.9637	1.0107	1.0405	1.0187	0.9812	0.9541
SR 417 (Central Florida GreeneWay)						
International Drive to SR 528 (Beachline Expressway)	0.9817	1.0037	1.0231	0.9569	0.9430	0.8998
SR 528 (Beachline Expressway) to Orange/Seminole County Line	1.0075	1.0106	0.9821	0.9560	0.9525	0.9613
SR 429 (Western Beltway and Wekiva Parkway)						
Seidel Road to CR 535 (Old Winter Garden Road)	0.9868	1.0099	1.0176	0.9699	0.9554	0.9041
CR 535 (Old Winter Garden Road to US 441 (Orange Blossom Trail))	1.0008	0.9991	0.9897	0.9584	0.9482	0.9260
SR 414 (Apopka Expressway)						
SR 429 / SR 451 to US 441 (Orange Blossom Trail)	1.0263	1.0246	1.0155	0.9936	0.9973	0.9780
SR 451 (Western Beltway Connector Road)						
SR 429 / SR 451 to US 441 (Orange Blossom Trail)	1.0136	1.0119	1.0026	0.9760	0.9728	0.9520

Average Annual Daily Traffic (AADT)

Monthly Seasonal Conversion Factors

CFX Expressway System	AADT Monthly Conversion Factors					
	January	February	March	April	May	June
SR 408 (East-West Expressway)						
Florida Turnpike (SR 91) to Interstate 4 (I-4)	1.0768	0.9978	0.9741	0.9688	1.0081	1.0014
Interstate 4 (I-4) to SR 50 (East Colonial Drive)	1.0554	0.9856	0.9822	0.9769	1.0188	1.0105
SR 528 (Beachline Expressway)						
Boggy Creek Road to SR 417 (Central Florida GreeneWay)	1.0580	0.9901	0.9344	0.9758	0.9997	0.9932
SR 417 (Central Florida GreeneWay) to SR 520	1.1218	1.0442	0.9228	0.9692	0.9711	0.9867
SR 417 (Central Florida GreeneWay)						
International Drive to SR 528 (Beachline Expressway)	1.1512	1.0439	0.9769	0.9907	1.0241	1.0155
SR 528 (Beachline Expressway) to Orange/Seminole County Line	1.1192	1.0236	0.9848	0.9751	1.0110	0.9976
SR 429 (Western Beltway and Wekiva Parkway)						
Seidel Road to CR 535 (Old Winter Garden Road)	1.1225	1.0410	0.9757	0.9910	1.0195	0.9912
CR 535 (Old Winter Garden Road to US 441 (Orange Blossom Trail)	1.1228	1.0289	1.0004	0.9942	1.0215	0.9979
SR 414 (Apopka Expressway)						
SR 429 / SR 451 to US 441 (Orange Blossom Trail)	0.8425	1.0412	1.0152	1.0033	1.0480	1.0205
SR 451 (Western Beltway Connector Road)						
SR 429 / SR 451 to US 441 (Orange Blossom Trail)	0.9826	1.0350	1.0078	0.9987	1.0348	1.0092

CFX Expressway System	AADT Monthly Conversion Factor					
	July	August	September	October	November	December
SR 408 (East-West Expressway)						
Florida Turnpike (SR 91) to Interstate 4 (I-4)	1.0247	1.0292	1.0005	0.9581	0.9892	0.9808
Interstate 4 (I-4) to SR 50 (East Colonial Drive)	1.0289	1.0320	0.9885	0.9459	0.9936	0.9894
SR 528 (Beachline Expressway)						
Boggy Creek Road to SR 417 (Central Florida GreeneWay)	0.9969	1.0493	1.0620	0.9963	0.9953	0.9645
SR 417 (Central Florida GreeneWay) to SR 520	0.9719	1.0226	1.0436	1.0165	0.9987	0.9634
SR 417 (Central Florida GreeneWay)						
International Drive to SR 528 (Beachline Expressway)	0.9829	1.0139	1.0317	0.9526	0.9615	0.9004
SR 528 (Beachline Expressway) to Orange/Seminole County Line	1.0031	1.0146	0.9863	0.9446	0.9793	0.9655
SR 429 (Western Beltway and Wekiva Parkway)						
Seidel Road to CR 535 (Old Winter Garden Road)	0.9896	1.0252	1.0267	0.9632	0.9738	0.9120
CR 535 (Old Winter Garden Road to US 441 (Orange Blossom Trail)	1.0016	1.0117	0.9954	0.9482	0.9699	0.9324
SR 414 (Apopka Expressway)						
SR 429 / SR 451 to US 441 (Orange Blossom Trail)	1.0271	1.0364	1.0219	0.9824	1.0238	0.9813
SR 451 (Western Beltway Connector Road)						
SR 429 / SR 451 to US 441 (Orange Blossom Trail)	1.0144	1.0240	1.0086	0.9653	0.9968	0.9569

Average Annual Weekday Traffic (AAWT) to Average Annual Daily Traffic (AADT)

Monthly Seasonal Conversion Factors

CFX Expressway System	AAWT to AADT Monthly Conversion Factors					
	January	February	March	April	May	June
SR 408 (East-West Expressway)						
Florida Turnpike (SR 91) to Interstate 4 (I-4)	1.0159	0.9909	0.9824	0.9822	1.0208	0.9823
Interstate 4 (I-4) to SR 50 (East Colonial Drive)	1.0129	0.9920	0.9881	0.9819	1.0116	0.9864
SR 528 (Beachline Expressway)						
Boggy Creek Road to SR 417 (Central Florida GreeneWay)	1.0023	0.9943	0.9879	0.9897	1.0099	0.9898
SR 417 (Central Florida GreeneWay) to SR 520	1.0103	0.9955	0.9876	0.9822	0.9812	0.9915
SR 417 (Central Florida GreeneWay)						
International Drive to SR 528 (Beachline Expressway)	1.0097	0.9893	0.9882	0.9886	0.9967	0.9923
SR 528 (Beachline Expressway) to Orange/Seminole County Line	1.0171	0.9909	0.9799	0.9779	1.0130	0.9817
SR 429 (Western Beltway and Wekiva Parkway)						
Seidel Road to CR 535 (Old Winter Garden Road)	1.0123	0.9822	0.9792	0.9857	1.0075	0.9864
CR 535 (Old Winter Garden Road to US 441 (Orange Blossom Trail)	1.0143	0.9830	0.9845	0.9831	1.0149	0.9841
SR 414 (Apopka Expressway)						
SR 429 / SR 451 to US 441 (Orange Blossom Trail)	1.0315	0.9843	0.9822	0.9761	1.0196	0.9811
SR 451 (Western Beltway Connector Road)						
SR 429 / SR 451 to US 441 (Orange Blossom Trail)	1.0229	0.9837	0.9833	0.9796	1.0173	0.9826

CFX Expressway System	AAWT to AADT Monthly Conversion Factor					
	July	August	September	October	November	December
SR 408 (East-West Expressway)						
Florida Turnpike (SR 91) to Interstate 4 (I-4)	0.9950	1.0079	1.0069	0.9845	1.0254	1.0091
Interstate 4 (I-4) to SR 50 (East Colonial Drive)	0.9979	1.0038	1.0042	0.9847	1.0269	1.0120
SR 528 (Beachline Expressway)						
Boggy Creek Road to SR 417 (Central Florida GreeneWay)	0.9958	1.0053	1.0011	0.9958	1.0170	1.0117
SR 417 (Central Florida GreeneWay) to SR 520	1.0086	1.0118	1.0030	0.9978	1.0179	1.0097
SR 417 (Central Florida GreeneWay)						
International Drive to SR 528 (Beachline Expressway)	1.0013	1.0102	1.0086	0.9955	1.0198	1.0007
SR 528 (Beachline Expressway) to Orange/Seminole County Line	0.9956	1.0040	1.0043	0.9881	1.0282	1.0045
SR 429 (Western Beltway and Wekiva Parkway)						
Seidel Road to CR 535 (Old Winter Garden Road)	1.0028	1.0152	1.0090	0.9931	1.0192	1.0087
CR 535 (Old Winter Garden Road to US 441 (Orange Blossom Trail)	1.0008	1.0125	1.0057	0.9894	1.0228	1.0069
SR 414 (Apopka Expressway)						
SR 429 / SR 451 to US 441 (Orange Blossom Trail)	1.0008	1.0115	1.0062	0.9888	1.0265	1.0034
SR 451 (Western Beltway Connector Road)						
SR 429 / SR 451 to US 441 (Orange Blossom Trail)	1.0008	1.0120	1.0060	0.9891	1.0247	1.0051



Section III: Mainline Toll Facility Characteristics



2017 Traffic Data and Statistics Manual
CENTRAL FLORIDA EXPRESSWAY AUTHORITY

Mainline Toll Facility Characteristics Introduction

The following pages provide a summary of the existing unadjusted traffic data that has been gathered at the mainline toll plazas located on the SR 408 (East West Expressway) at the Hiawassee Mainline, Pine Hills Mainline, Conway Mainline and Dean Mainline, on SR 528 (Beachline Expressway) at the Beachline Mainline and Dallas Mainline, on SR 417 (Central Florida Greenway) at the John Young Mainline, Boggy Creek Mainline, Curry Ford Mainline and the University Mainline, on SR 429 (Western Beltway and Wekiva Parkway) at the Forest Lake Mainline, Independence Mainline, and Ponkan Gantry, on SR 414 (Apopka Expressway) at the Coral Hills Mainline, and on the Non System Goldenrod Extension at the Goldenrod Mainline.

The data for the mainline toll plazas includes the following:

- Figures summarizing the type and number of lanes through the Mainline Toll Plaza.
- Mainline and Ramp Toll Plaza monthly toll transactions and revenue obtained from the Monthly Statistical Reports Fiscal Year 2017.
- Typical Total Daily Expressway Traffic obtained for entire month of April (Monday through Sunday) from the toll plaza data statistics. (Mainline Tolls Only)
- Unadjusted typical average five-day (weekday) & seven-day (daily) traffic volume summaries obtained from the toll plaza data statistics.
- Unadjusted typical average weekday peak hour characteristics summarizing the peak to daily ratio (“K”) and the directional distribution (“D”) factors.
- Unadjusted typical average weekday transactions summarizing the percentages for electronic E-PASS, Exact Change (ACM) and Change/Receipt (Manual).
- Historical and Existing Year E-PASS, Cash and Violation percentages.

Hiawassee Mainline Toll Facility (East-West Expressway)



2017 Traffic Data and Statistics Manual
CENTRAL FLORIDA EXPRESSWAY AUTHORITY



Admin.
Bldg.

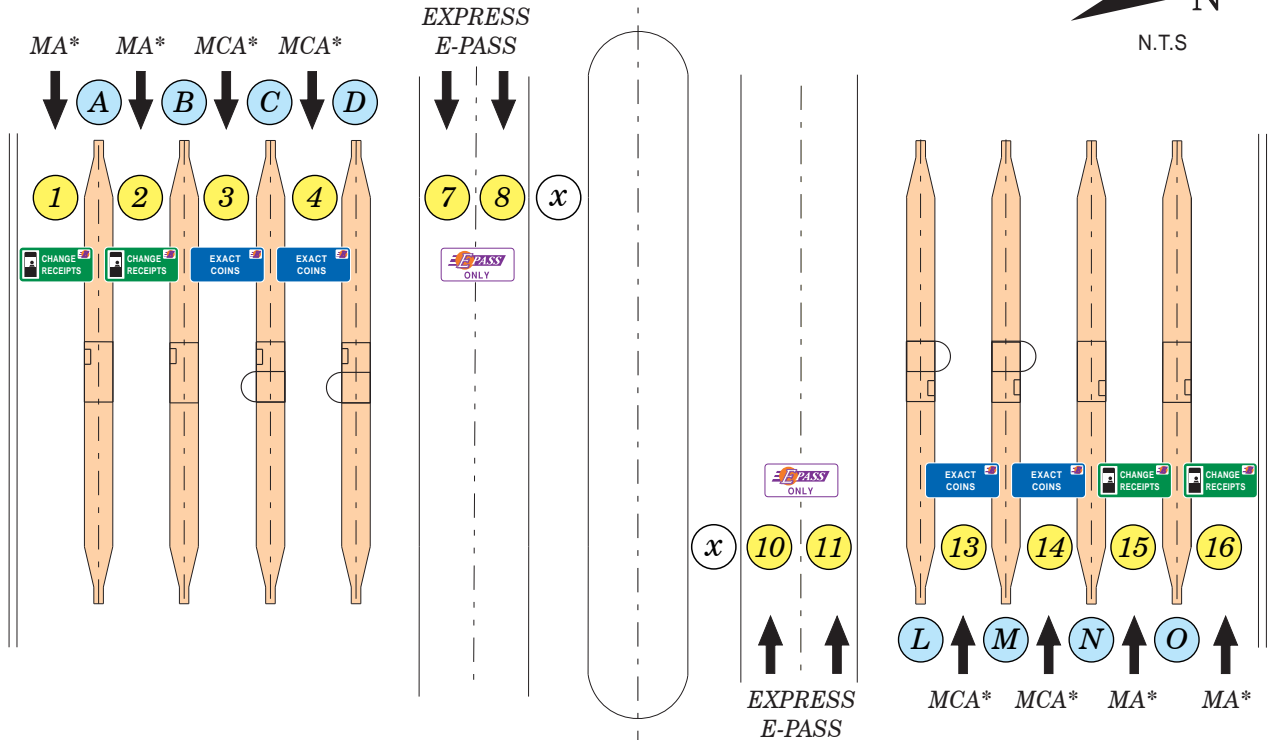

HISTORIC TRAFFIC - A.A.W.T.

1992	11,620 (POST TOLL)	2015	69,490
1993	13,570	2016	73,510
1994	16,650	2017	72,200
1995	18,460		
1996	23,250		
1997	25,830		
1998	31,400		
1999	34,370		
2000	41,040		
2001	45,180		
2002	49,490		
2003	53,070		
2004	59,370		
2005	59,700		
2006	64,200		
2007	66,820		
2008	61,620		
2009	59,900 (Toll Increase April 2009)		
2010	56,680		
2011	57,170		
2012	56,330 (Toll Increase July 2012)		
2013	57,750		
2014	61,440		

	<u>TOLL RATE STRUCTURE</u>	
	<u>E-PASS</u>	<u>CASH</u>
2 Axles	\$.82	\$ 1.00
3 Axles	\$ 1.64	\$ 1.75
4 Axles	\$ 1.91	\$ 2.00
5 Axles or more	\$ 2.46	\$ 2.50

LANES OF EQUIPMENT
 4 Manned Booth with E-PASS (MA)
 2 Booths with Automatic Coin Machines with E-PASS (MCA)
 4 Express E-PASS (E-PASS only)
 * Changeable Message Sign

- LEGEND**
- ① Lane Number
 - Ⓐ Island Designation
 - ⓧ Under Construction by Project #408-127



**SR 408 (EAST-WEST EXPRESSWAY)
Hiwassee Mainline Toll Facility**



 N
Approx. Scale: 1" = 200'
January 2017

Hiwassee Mainline Toll Facility

SR 408 - East-West Expressway

Fiscal Year 2017 Monthly Mainline & Ramp Toll Transactions and Revenue Summary

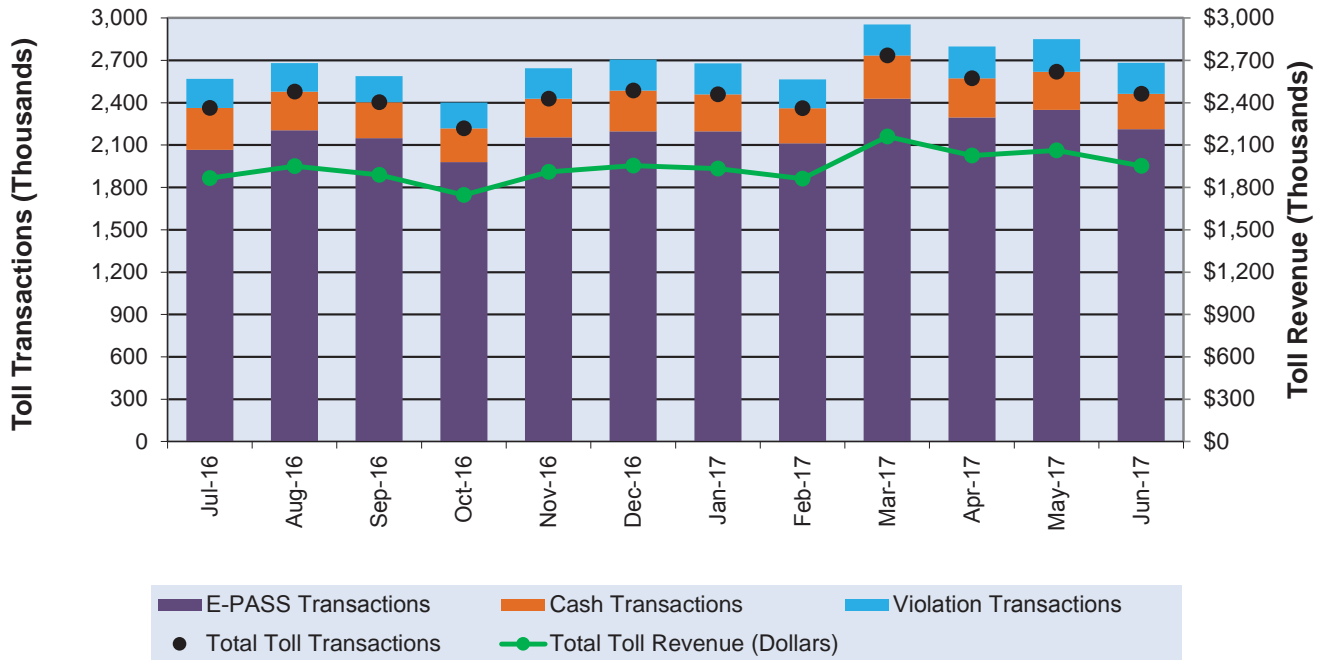

Month	FY 17 MONTHLY MAINLINE & RAMP TOLL TRANSACTIONS					Total Toll Revenue
	E-PASS	Cash	Total Revenue	Violations	Total	
July-16	2,066,230	297,203	2,363,433	205,635	2,569,068	\$1,865,920
August-16	2,205,079	273,152	2,478,231	202,415	2,680,646	\$1,951,597
September-16	2,148,800	254,374	2,403,174	185,359	2,588,533	\$1,888,849
October-16	1,979,395	239,076	2,218,471	183,423	2,401,894	\$1,746,988
November-16	2,155,165	273,012	2,428,177	216,959	2,645,136	\$1,910,390
December-16	2,197,974	289,037	2,487,011	218,498	2,705,509	\$1,954,482
January-17	2,198,177	261,316	2,459,493	219,704	2,679,197	\$1,934,006
February-17	2,111,981	249,824	2,361,805	204,307	2,566,112	\$1,862,748
March-17	2,429,117	305,276	2,734,393	219,807	2,954,200	\$2,159,835
April-17	2,295,099	278,528	2,573,627	224,141	2,797,768	\$2,025,759
May-17	2,349,375	270,374	2,619,749	229,902	2,849,651	\$2,062,655
June-17	2,212,003	251,972	2,463,975	218,156	2,682,131	\$1,952,577
Yearly Totals	26,348,395	3,243,144	29,591,539	2,528,306	32,119,845	\$23,315,806

Note: Data includes ramp toll plazas that report to the Hiwassee Mainline Toll Plaza.

- Cash transactions were calculated as the difference between total revenue traffic and E-PASS traffic
- All plazas had tolls suspended in FY 17 due to Hurricane Matthew from 10/5/16 until early on 10/10/16

Hiwassee Mainline Toll Facility
SR 408 - East-West Expressway
Typical Daily Traffic Volumes - April 2017

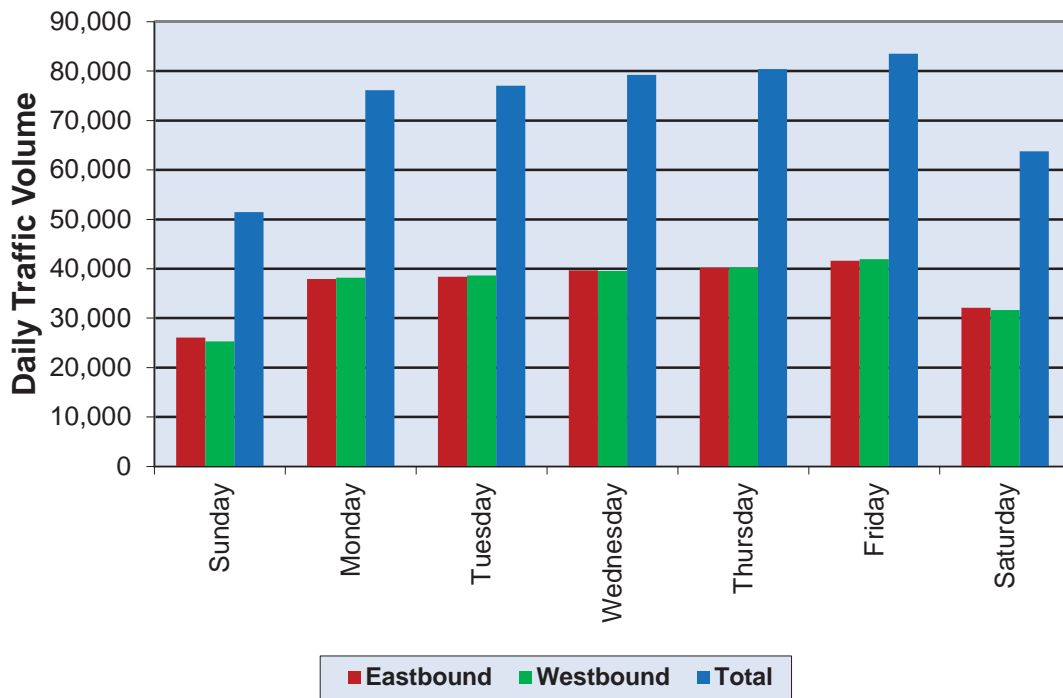

Day	Expressway Traffic Volumes		
	Eastbound	Westbound	Total
Sunday	26,110	25,330	51,440
Monday	37,960	38,190	76,150
Tuesday	38,380	38,640	77,020
Wednesday	39,660	39,570	79,230
Thursday	40,190	40,250	80,440
Friday	41,600	41,960	83,560
Saturday	32,120	31,660	63,780

Hiwassee Mainline Toll Facility SR 408 - East-West Expressway Average Five Day Hourly Traffic - April 2017

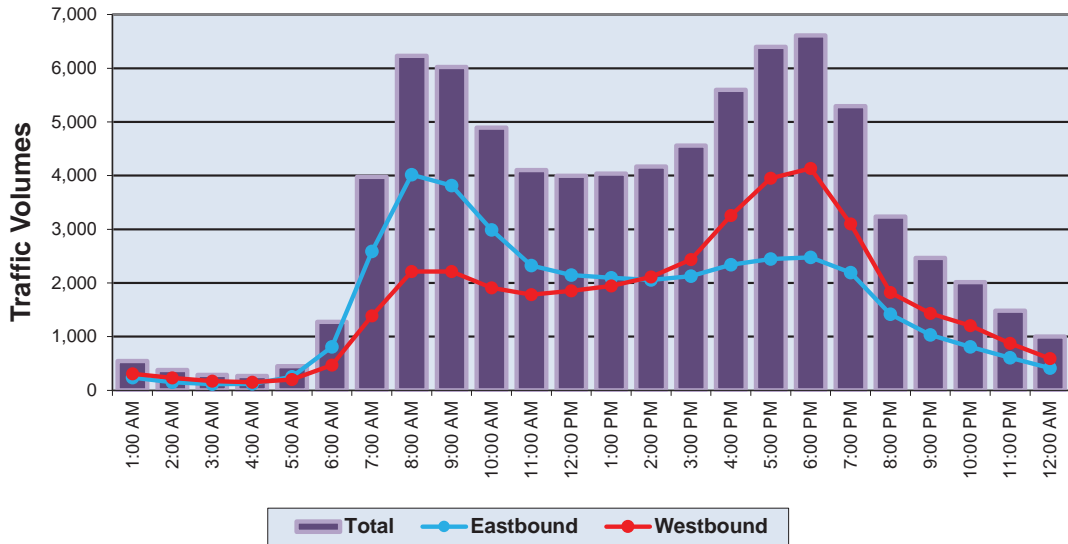

Hour Ending	Average Weekday Volumes		
	Eastbound	Westbound	Total
1:00 AM	235	308	543
2:00 AM	148	230	378
3:00 AM	113	172	285
4:00 AM	121	147	268
5:00 AM	249	198	447
6:00 AM	808	467	1,275
7:00 AM	2,588	1,387	3,975
8:00 AM	4,018	2,213	6,231
9:00 AM	3,814	2,210	6,024
10:00 AM	2,985	1,908	4,893
11:00 AM	2,323	1,781	4,104
12:00 PM	2,147	1,850	3,997

Hour Ending	Average Weekday Volumes		
	Eastbound	Westbound	Total
1:00 PM	2,094	1,945	4,039
2:00 PM	2,055	2,111	4,166
3:00 PM	2,127	2,434	4,561
4:00 PM	2,341	3,258	5,599
5:00 PM	2,447	3,952	6,399
6:00 PM	2,477	4,132	6,609
7:00 PM	2,194	3,098	5,292
8:00 PM	1,414	1,823	3,237
9:00 PM	1,032	1,431	2,463
10:00 PM	809	1,205	2,014
11:00 PM	607	874	1,481
12:00 AM	414	589	1,003

Total Eastbound	39,560
Total Westbound	39,723
Total Weekday	79,283

Hiwassee Mainline Toll Facility SR 408 - East-West Expressway Average Seven Day Hourly Traffic - April 2017

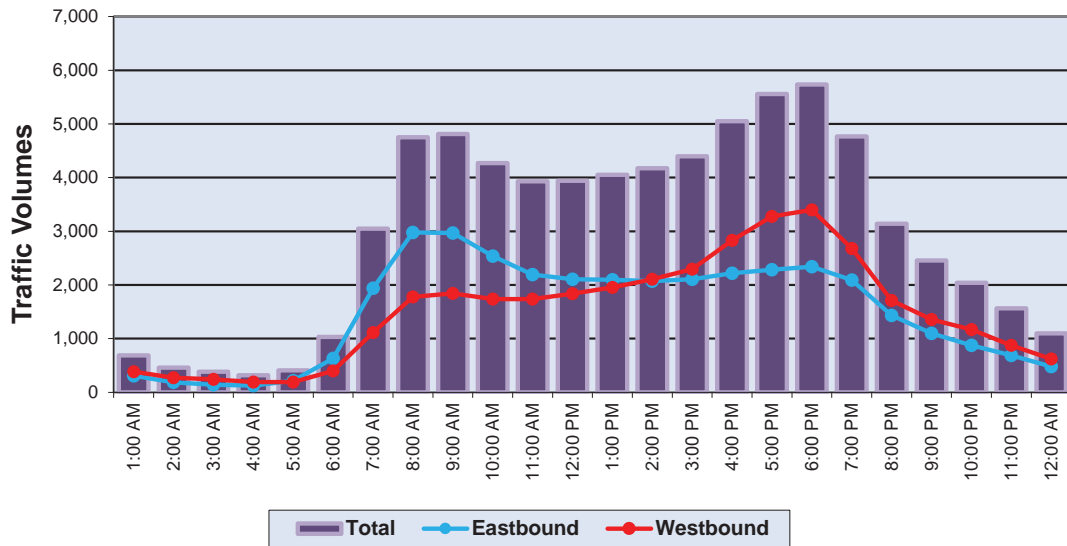

Hour Ending	Average Weekday Volumes		
	Eastbound	Westbound	Total
1:00 AM	306	381	687
2:00 AM	184	273	457
3:00 AM	139	243	382
4:00 AM	126	189	315
5:00 AM	217	191	408
6:00 AM	630	399	1,030
7:00 AM	1,936	1,114	3,050
8:00 AM	2,975	1,775	4,750
9:00 AM	2,967	1,842	4,810
10:00 AM	2,538	1,734	4,271
11:00 AM	2,194	1,736	3,930
12:00 PM	2,104	1,838	3,942

Hour Ending	Average Weekday Volumes		
	Eastbound	Westbound	Total
1:00 PM	2,095	1,955	4,051
2:00 PM	2,072	2,104	4,175
3:00 PM	2,104	2,295	4,399
4:00 PM	2,216	2,832	5,048
5:00 PM	2,282	3,275	5,557
6:00 PM	2,337	3,399	5,736
7:00 PM	2,089	2,676	4,765
8:00 PM	1,430	1,711	3,140
9:00 PM	1,098	1,357	2,455
10:00 PM	874	1,166	2,040
11:00 PM	688	876	1,564
12:00 AM	477	620	1,097

Total Eastbound	36,078
Total Westbound	35,979
Total Weekday	72,057

Hiwassee Mainline Toll Facility

Toll Facility Peak Hour Characteristic Summary Typical Average Weekday (Monday through Friday) - April 2017

Average Weekday Traffic Summary (unadjusted)

Average Weekday Total Traffic	79,283
Eastbound Directional Traffic	39,560
Westbound Directional Traffic	39,723

Morning Peak Hour Summary (7:00 a.m. to 8:00 a.m.)

Eastbound Directional Traffic	4,018
Westbound Directional Traffic	2,213
Total AM Peak Hour Traffic	6,231

AM Peak Hour Factor ("K") = Total Peak Hour Traffic / Average Weekday Total Traffic

AM Peak Hour Factor ("K_{am}") 7.86%

AM Peak Hour Directional Factor ("D") = Peak Directional Traffic / Total Peak Hour Traffic

AM Peak Hour Directional Factor ("D_{am}") 64.48%

Evening Peak Hour Summary (5:00 p.m. to 6:00 p.m.)

Eastbound Directional Traffic	2,477
Westbound Directional Traffic	4,132
Total PM Peak Hour Traffic	6,609

PM Peak Hour Factor ("K") = Total Peak Hour Traffic / Average Weekday Total Traffic

PM Peak Hour Factor ("K_{pm}") 8.34%

PM Peak Hour Directional Factor ("D") = Peak Directional Traffic / Total Peak Hour Traffic

PM Peak Hour Directional Factor ("D_{pm}") 62.52%

Hiwassee Mainline Toll Facility

Toll Transaction Summary

Typical Average Weekday (Monday through Friday) - April 2017

Average Weekday Summary

Direction of Travel	E-PASS (AVI)		ACM (Coin)		Manual (Cash)		Total	
	Volume	% Usage	Volume	% Usage	Volume	% Usage	Traffic	% Usage
Eastbound	35,145	89%	1,053	3%	3,362	8%	39,560	100%
Westbound	36,196	91%	925	2%	2,602	7%	39,723	100%

Morning Peak Hour Summary (7:00 a.m. to 8:00 a.m.)

Direction of Travel	E-PASS (AVI)		ACM (Coin)		Manual (Cash)		Total	
	Volume	% Usage	Volume	% Usage	Volume	% Usage	Traffic	% Usage
Eastbound	3,174	79%	654	16%	190	5%	4,018	100%
Westbound	2,017	91%	40	2%	156	7%	2,213	100%

Evening Peak Hour Summary (5:00 p.m. to 6:00 p.m.)

Direction of Travel	E-PASS (AVI)		ACM (Coin)		Manual (Cash)		Total	
	Volume	% Usage	Volume	% Usage	Volume	% Usage	Traffic	% Usage
Eastbound	2,233	90%	12	0%	232	9%	2,477	100%
Westbound	3,809	92%	129	3%	194	5%	4,132	100%

Hiwassee Mainline Toll Facility SR 408 - East-West Expressway Historical & Existing Total Revenue Transactions Statistics

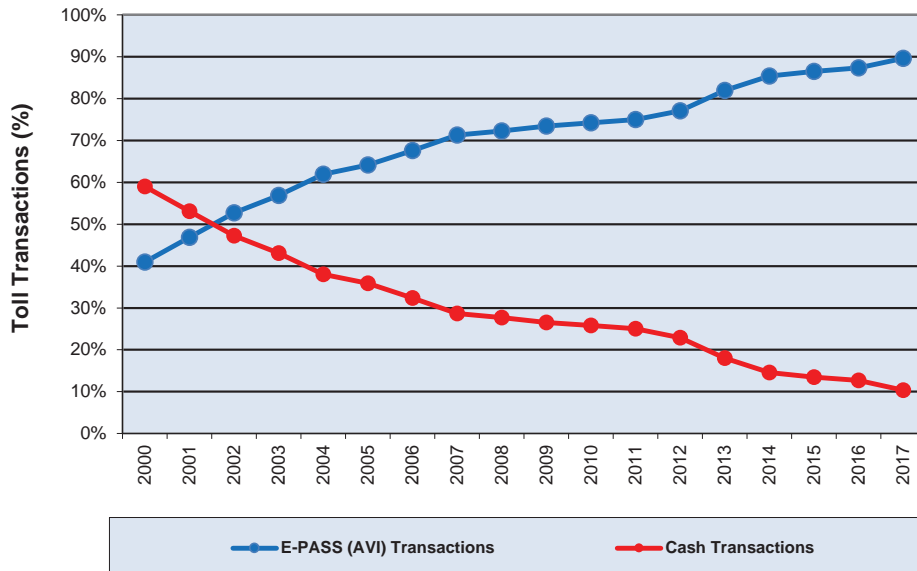

Year	Yearly Revenue Transaction		% Violations ⁽²⁾ (Percent of Total Transactions)
	% E-PASS (AVI) Transactions	% Cash Transactions	
2000	41.0%	59.0%	2.2%
2001	46.9%	53.1%	1.9%
2002	52.7%	47.3%	2.1%
2003	56.9%	43.1%	1.2%
2004	61.9%	38.1%	1.4%
2005	64.1%	35.9%	1.5%
2006	67.6%	32.4%	2.8%
2007	71.3%	28.7%	2.6%
2008	72.3%	27.7%	2.4%
2009	73.5%	26.5%	2.8%
2010	74.2%	25.8%	3.0%
2011	75.0%	25.0%	3.0%
2012	77.1%	22.9%	3.2%
2013	82.0%	18.0%	3.7%
2014	85.4%	14.6%	4.6%
2015	86.5%	13.5%	5.4%
2016	87.3%	12.7%	6.2%
2017	89.6%	10.4%	8.8%

1. All plazas had tolls suspended from 9/5/17 until 9/21/17 due to Hurricane Irma

2. Calculated as percent of Total Transactions, which is equal to Revenue Transactions plus Violations

Pine Hills Mainline Toll Facility (East-West Expressway)



2017 Traffic Data and Statistics Manual
CENTRAL FLORIDA EXPRESSWAY AUTHORITY

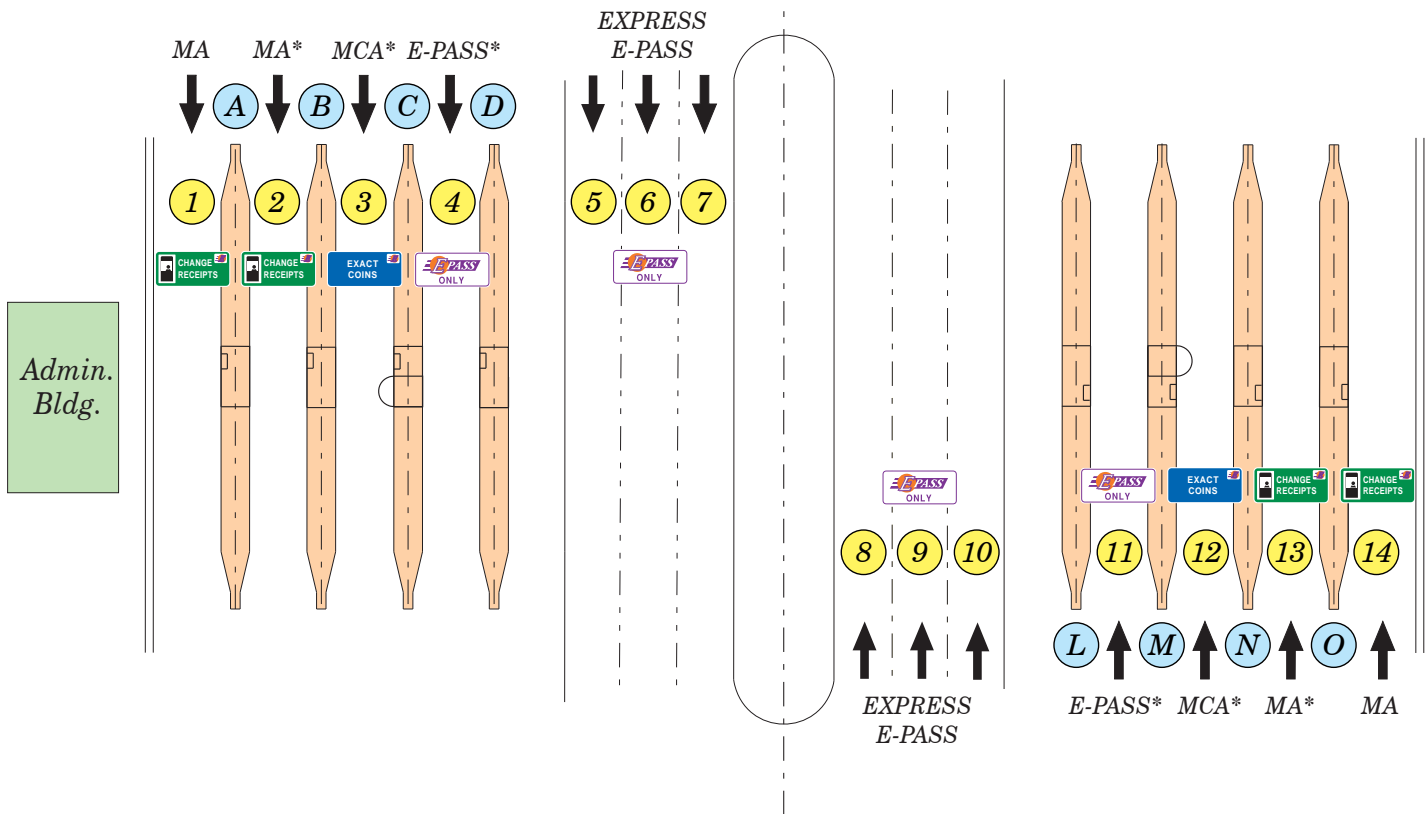

HISTORIC TRAFFIC - A.A.W.T.

2006	78,660
2007	82,710
2008	77,800
2009	69,800 (Toll Increase April 2009)
2010	71,150
2011	72,070
2012	71,190 (Toll Increase July 2012)
2013	72,020
2014	77,210
2015	85,210
2016	89,080
2017	94,910

TOLL RATE STRUCTURE

	<u>E-PASS</u>	<u>CASH</u>
2 Axles	\$ 1.09	\$ 1.25
3 Axles	\$ 1.64	\$ 1.75
4 Axles	\$ 1.91	\$ 2.00
5 Axles or more	\$ 2.46	\$ 2.50

LANES OF EQUIPMENT

- 4 Manned Booths with E-PASS (MA)
- 2 Booths with Automatic Coin Machines with E-PASS (MCA)
- 2 Booths with Dedicated E-PASS
- 6 Express E-PASS only

* Changeable Message Sign

LEGEND

- ① Lane Number
- Ⓐ Island Designation



Approx. Scale: 1" = 200'
January 2017

Pine Hills Mainline Toll Facility SR 408 - East-West Expressway

Fiscal Year 2017 Monthly Mainline & Ramp Toll Transactions and Revenue Summary

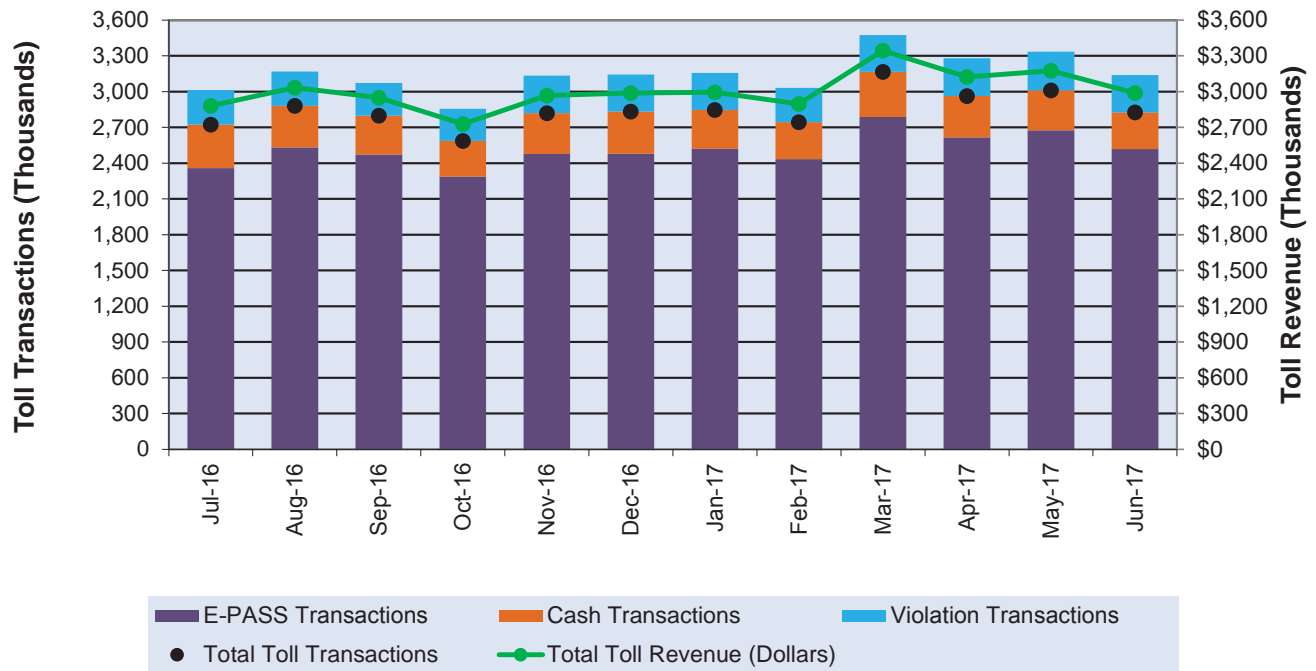

Month	FY 17 MONTHLY MAINLINE & RAMP TOLL TRANSACTIONS					Total Toll Revenue
	E-PASS	Cash	Total Revenue	Violations	Total	
July-16	2,357,765	365,437	2,723,202	289,267	3,012,469	\$2,880,924
August-16	2,532,613	347,428	2,880,041	289,014	3,169,055	\$3,033,370
September-16	2,471,883	326,743	2,798,626	273,927	3,072,553	\$2,948,682
October-16	2,286,508	301,042	2,587,550	268,790	2,856,340	\$2,728,445
November-16	2,477,192	341,566	2,818,758	315,972	3,134,730	\$2,968,528
December-16	2,479,969	353,639	2,833,608	310,236	3,143,844	\$2,988,024
January-17	2,520,246	326,506	2,846,752	310,541	3,157,293	\$2,995,681
February-17	2,432,625	311,596	2,744,221	287,609	3,031,830	\$2,896,359
March-17	2,788,019	378,185	3,166,204	308,605	3,474,809	\$3,343,740
April-17	2,615,710	347,052	2,962,762	316,252	3,279,014	\$3,123,038
May-17	2,674,573	335,639	3,010,212	325,500	3,335,712	\$3,175,480
June-17	2,517,498	309,309	2,826,807	311,073	3,137,880	\$2,987,668
Yearly Totals	30,154,601	4,044,142	34,198,743	3,606,786	37,805,529	\$36,069,939

Note: Data includes ramp toll plazas that report to the Pine Hills Mainline Toll Plaza.

1. Cash transactions were calculated as the difference between total revenue traffic and E-PASS traffic
2. All plazas had tolls suspended in FY 17 due to Hurricane Matthew from 10/5/16 until early on 10/10/16



Pine Hills Mainline Toll Facility
SR 408 - East-West Expressway
Typical Daily Traffic Volumes - April 2017

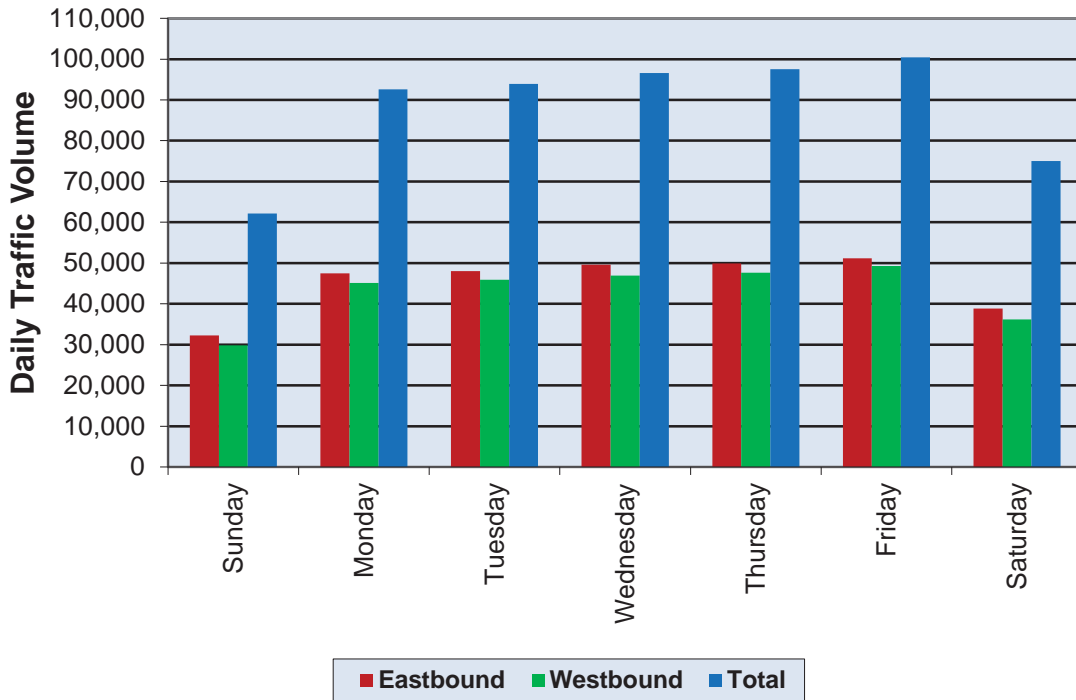

Day	Expressway Traffic Volumes		
	Eastbound	Westbound	Total
Sunday	32,280	29,860	62,140
Monday	47,450	45,150	92,600
Tuesday	48,000	45,940	93,940
Wednesday	49,620	46,940	96,560
Thursday	49,890	47,670	97,560
Friday	51,160	49,290	100,450
Saturday	38,830	36,180	75,010

Pine Hills Mainline Toll Facility
SR 408 - East-West Expressway
Average Five Day Hourly Traffic - April 2017

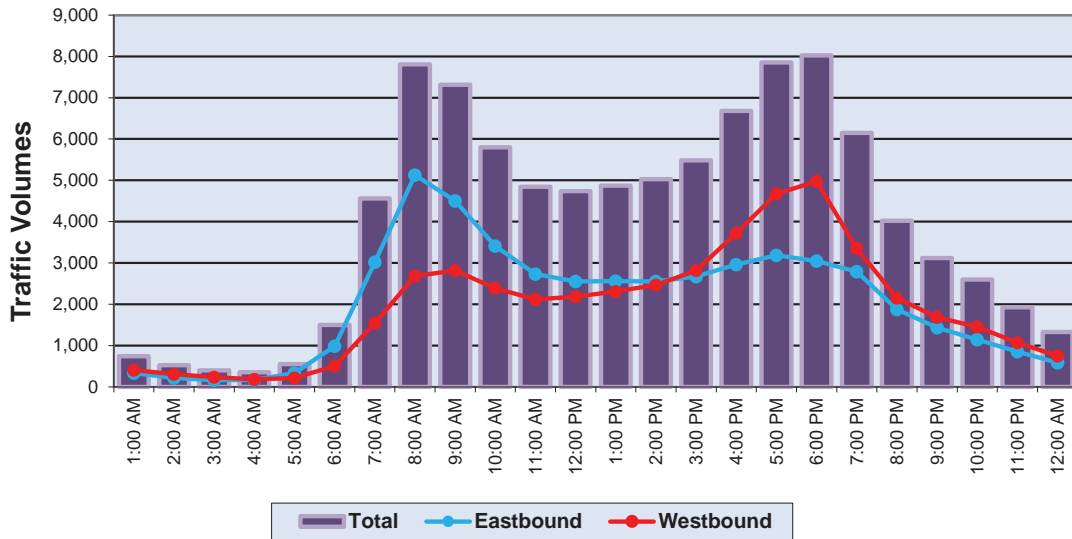

Hour Ending	Average Weekday Volumes		
	Eastbound	Westbound	Total
1:00 AM	336	406	742
2:00 AM	218	308	526
3:00 AM	160	237	397
4:00 AM	171	180	351
5:00 AM	335	215	550
6:00 AM	988	508	1,496
7:00 AM	3,019	1,543	4,562
8:00 AM	5,128	2,681	7,809
9:00 AM	4,501	2,815	7,316
10:00 AM	3,407	2,389	5,796
11:00 AM	2,728	2,117	4,845
12:00 PM	2,552	2,185	4,737

Hour Ending	Average Weekday Volumes		
	Eastbound	Westbound	Total
1:00 PM	2,557	2,311	4,868
2:00 PM	2,555	2,470	5,025
3:00 PM	2,669	2,813	5,482
4:00 PM	2,958	3,720	6,678
5:00 PM	3,184	4,670	7,854
6:00 PM	3,049	4,974	8,023
7:00 PM	2,788	3,358	6,146
8:00 PM	1,875	2,148	4,023
9:00 PM	1,434	1,682	3,116
10:00 PM	1,145	1,454	2,599
11:00 PM	856	1,071	1,927
12:00 AM	583	747	1,330

Total Eastbound	49,196
Total Westbound	47,002
Total Weekday	96,198

Pine Hills Mainline Toll Facility
SR 408 - East-West Expressway
Average Seven Day Hourly Traffic - April 2017

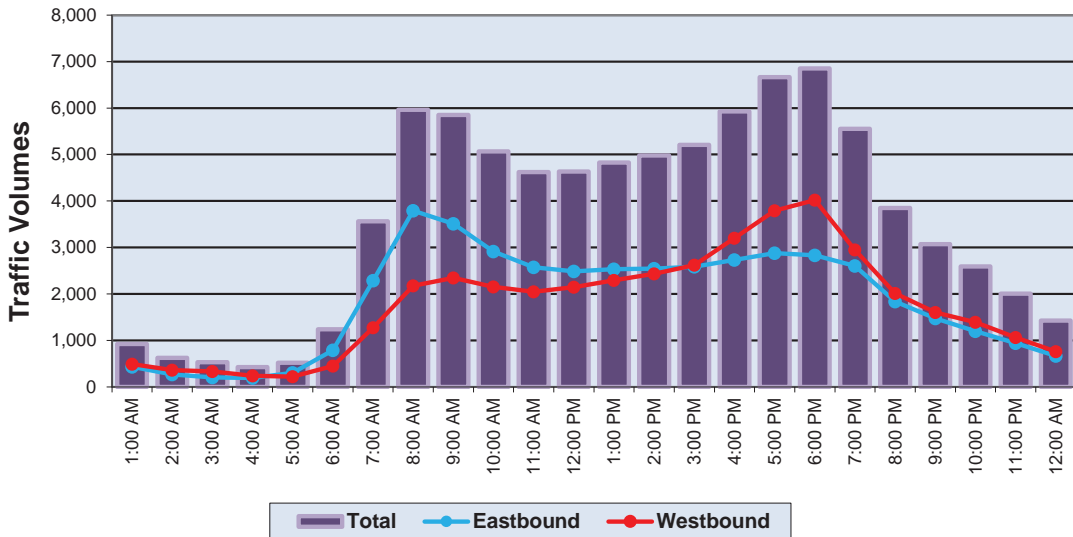

Hour Ending	Average Weekday Volumes		
	Eastbound	Westbound	Total
1:00 AM	432	489	921
2:00 AM	266	360	625
3:00 AM	200	329	530
4:00 AM	190	236	426
5:00 AM	300	218	518
6:00 AM	790	447	1,236
7:00 AM	2,285	1,277	3,562
8:00 AM	3,789	2,175	5,964
9:00 AM	3,508	2,344	5,851
10:00 AM	2,911	2,154	5,065
11:00 AM	2,576	2,048	4,624
12:00 PM	2,486	2,146	4,632

Hour Ending	Average Weekday Volumes		
	Eastbound	Westbound	Total
1:00 PM	2,533	2,292	4,826
2:00 PM	2,546	2,433	4,979
3:00 PM	2,587	2,618	5,206
4:00 PM	2,731	3,198	5,929
5:00 PM	2,876	3,789	6,665
6:00 PM	2,834	4,021	6,854
7:00 PM	2,603	2,951	5,553
8:00 PM	1,839	2,010	3,848
9:00 PM	1,472	1,599	3,071
10:00 PM	1,199	1,391	2,590
11:00 PM	940	1,065	2,005
12:00 AM	664	761	1,426

Total Eastbound	44,556
Total Westbound	42,350
Total Weekday	86,906

Pine Hills Mainline Toll Facility

Toll Transaction Summary

Typical Average Weekday (Monday through Friday) - April 2017

Average Weekday Summary

Direction of Travel	E-PASS (AVI)		ACM (Coin)		Manual (Cash)		Total	
	Volume	% Usage	Volume	% Usage	Volume	% Usage	Traffic	% Usage
Eastbound	44,143	90%	1,259	3%	3,794	8%	49,196	100%
Westbound	42,565	91%	1,143	2%	3,294	7%	47,002	100%

Morning Peak Hour Summary (7:00 a.m. to 8:00 a.m.)

Direction of Travel	E-PASS (AVI)		ACM (Coin)		Manual (Cash)		Total	
	Volume	% Usage	Volume	% Usage	Volume	% Usage	Traffic	% Usage
Eastbound	4,780	93%	87	2%	261	5%	5,128	100%
Westbound	2,462	92%	55	2%	164	6%	2,681	100%

Evening Peak Hour Summary (5:00 p.m. to 6:00 p.m.)

Direction of Travel	E-PASS (AVI)		ACM (Coin)		Manual (Cash)		Total	
	Volume	% Usage	Volume	% Usage	Volume	% Usage	Traffic	% Usage
Eastbound	2,753	90%	65	2%	231	8%	3,049	100%
Westbound	4,602	93%	98	2%	274	6%	4,974	100%

Pine Hills Mainline Toll Facility
SR 408 - East-West Expressway
Historical & Existing Total Revenue Transactions Statistics

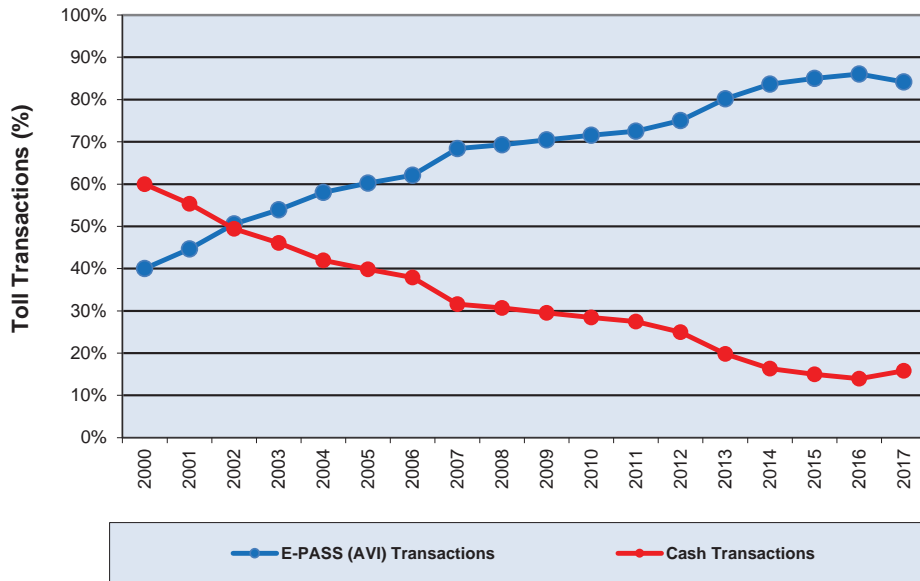

Year	Yearly Revenue Transaction		% Violations ⁽²⁾ (Percent of Total Transactions)
	% E-PASS (AVI) Transactions	% Cash Transactions	
2000	40.0%	60.0%	3.0%
2001	44.7%	55.3%	2.6%
2002	50.6%	49.4%	2.1%
2003	53.9%	46.1%	2.1%
2004	58.1%	41.9%	2.1%
2005	60.2%	39.8%	2.4%
2006	62.1%	37.9%	2.7%
2007	68.4%	31.6%	4.5%
2008	69.3%	30.7%	3.6%
2009	70.5%	29.5%	3.7%
2010	71.6%	28.4%	4.0%
2011	72.5%	27.5%	4.0%
2012	75.0%	25.0%	4.2%
2013	80.2%	19.8%	4.7%
2014	83.7%	16.3%	5.7%
2015	85.0%	15.0%	6.6%
2016	86.0%	14.0%	7.6%
2017	84.2%	15.8%	9.2%

1. All plazas had tolls suspended from 9/5/17 until 9/21/17 due to Hurricane Irma

2. Calculated as percent of Total Transactions, which is equal to Revenue Transactions plus Violations

Conway East & West Mainline Toll Facility (East-West Expressway)



2017 Traffic Data and Statistics Manual
CENTRAL FLORIDA EXPRESSWAY AUTHORITY

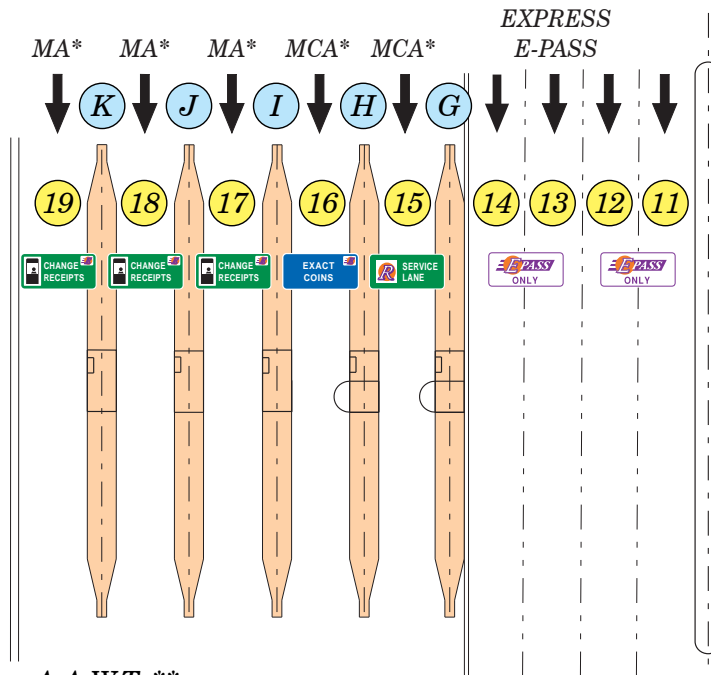

HISTORIC TRAFFIC - A.A.W.T. **

1992	NO COUNT (POST TOLL)
1993	62,620
1994	64,650
1995	73,020
1996	77,400
1997	87,810
1998	94,450
1999	98,850
2000	105,200
2001	107,940
2002	110,130
2003	116,000
2004	125,460
2005	123,500
2006	125,000
2007	118,100
2008	112,200
2009	112,750 (Toll Increase April 2009)
2010	117,830
2011	119,600
2012	117,530 (Toll Increase July 2012)
2013	115,530
2014	122,400
2015	132,940
2016	140,380
2017	147,220

Notes: Lane 15 E-PASS Reload Lane
Lane 14 opened to traffic Q4 of 2017

	<u>E-PASS</u>	<u>CASH</u>
2 Axles	\$ 1.09	\$ 1.25
3 Axles	\$ 1.64	\$ 1.75
4 Axles	\$ 1.91	\$ 2.00
5 Axles or more	\$ 2.46	\$ 2.50

LANES OF EQUIPMENT (EAST)
 3 Manned Booths with E-PASS (MA)
 2 Booths with Automatic Coin Machines (MCA) with E-PASS
 3 Express E-PASS (E-PASS only)
 * Changeable Message Sign

LEGEND
 ① Lane Number
 Ⓐ Island Designation

** Historic traffic includes both the Conway East & West Mainline Toll Facilities



**SR 408 (EAST-WEST EXPRESSWAY)
Conway East Mainline Toll Facility**

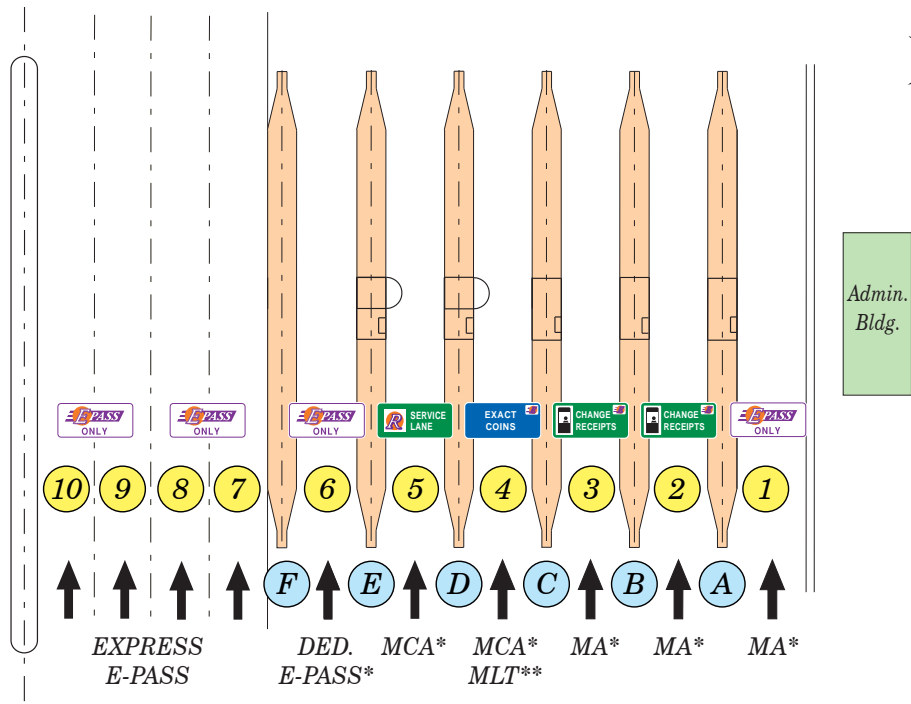

Notes: Lane 5 E-PASS Reload Lane
Lane 4 opened to traffic Q4 of 2017

HISTORIC TRAFFIC - A.A.WT. **

1992	NO COUNT (POST TOLL)	2015	132,940
1993	62,620	2016	140,380
1994	64,650	2017	147,220
1995	73,020		
1996	77,400		
1997	87,810		
1998	94,450		
1999	98,850		
2000	105,200		
2001	107,940		
2002	110,130		
2003	116,000		
2004	125,460		
2005	123,500		
2006	125,000		
2007	118,100		
2008	112,200		
2009	112,750 (Toll Increase April 2009)		
2010	117,830		
2011	119,600		
2012	117,530 (Toll Increase July 2012)		
2013	115,530		
2014	122,400		

	<u>E-PASS</u>	<u>CASH</u>
2 Axles	\$ 1.09	\$ 1.25
3 Axles	\$ 1.64	\$ 1.75
4 Axles	\$ 1.91	\$ 2.00
5 Axles or more	\$ 2.46	\$ 2.50

LANES OF EQUIPMENT (WEST)
 3 Manned Booths with E-PASS (MA)
 2 Booths with Automatic Coin Machines (MCA) with E-PASS
 1 Dedicated E-PASS
 3 Express E-PASS (E-PASS only)
 * Changeable Message Sign

LEGEND
 ① Lane Number
 Ⓐ Island Designation

** Historic traffic includes both the Conway East & West Mainline Toll Facilities



**SR 408 (EAST-WEST EXPRESSWAY)
Conway West Mainline Toll Facility**



Approx. Scale: 1" = 300'
January 2017

Conway Mainline Toll Facility SR 408 - East-West Expressway

Fiscal Year 2017 Monthly Mainline & Ramp Toll Transactions and Revenue Summary

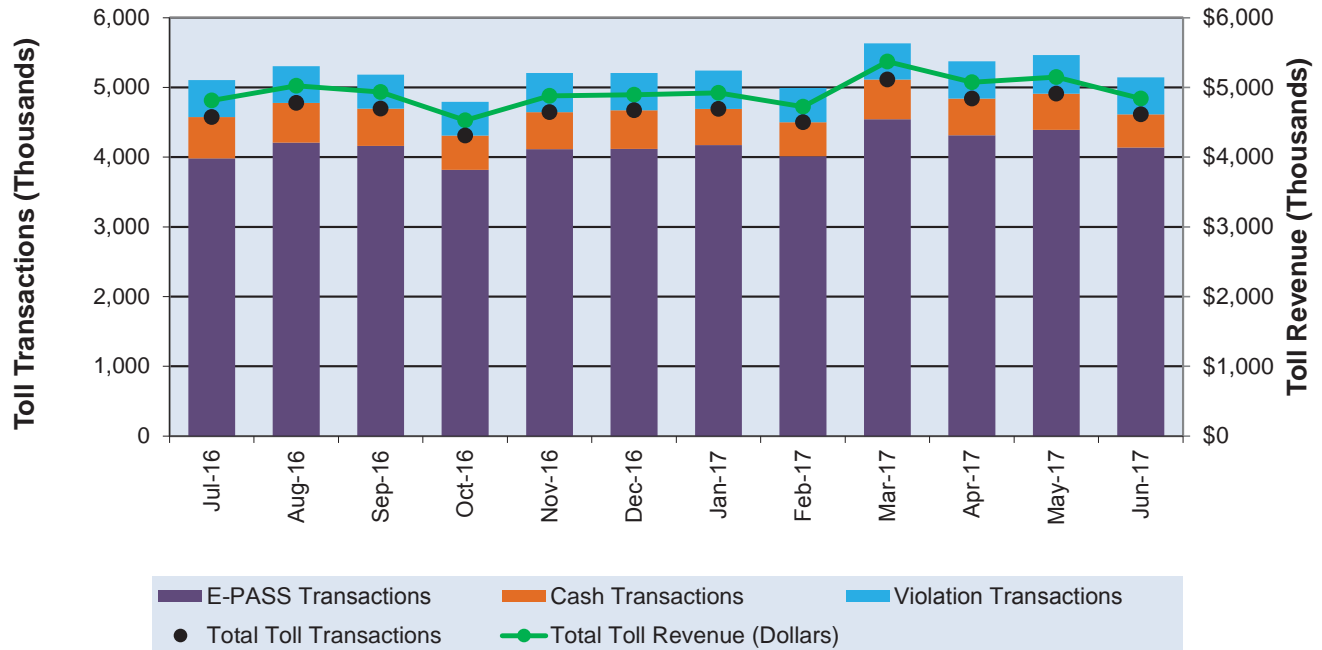

Month	FY 17 MONTHLY MAINLINE & RAMP TOLL TRANSACTIONS					Total Toll Revenue
	E-PASS	Cash	Total Revenue	Violations	Total	
July-16	3,981,471	591,465	4,572,936	530,804	5,103,740	\$4,811,581
August-16	4,208,129	571,040	4,779,169	524,221	5,303,390	\$5,023,925
September-16	4,162,666	534,460	4,697,126	486,106	5,183,232	\$4,933,902
October-16	3,818,109	489,727	4,307,836	484,956	4,792,792	\$4,526,414
November-16	4,113,789	532,112	4,645,901	558,648	5,204,549	\$4,877,343
December-16	4,118,851	551,420	4,670,271	537,562	5,207,833	\$4,894,645
January-17	4,173,140	517,465	4,690,605	552,457	5,243,062	\$4,921,419
February-17	4,014,321	486,491	4,500,812	490,636	4,991,448	\$4,723,589
March-17	4,544,652	568,085	5,112,737	519,515	5,632,252	\$5,371,861
April-17	4,312,465	527,687	4,840,152	534,950	5,375,102	\$5,073,589
May-17	4,391,647	517,883	4,909,530	554,176	5,463,706	\$5,147,014
June-17	4,137,462	475,406	4,612,868	531,753	5,144,621	\$4,840,648
Yearly Totals	49,976,702	6,363,241	56,339,943	6,305,784	62,645,727	\$59,145,930

Note: Data includes ramp toll plazas that report to the Conway Mainline Toll Plaza.

1. Cash transactions were calculated as the difference between total revenue traffic and E-PASS traffic
2. All plazas had tolls suspended in FY 17 due to Hurricane Matthew from 10/5/16 until early on 10/10/16

Conway Mainline Toll Facility
SR 408 - East-West Expressway
Typical Daily Traffic Volumes - April 2017

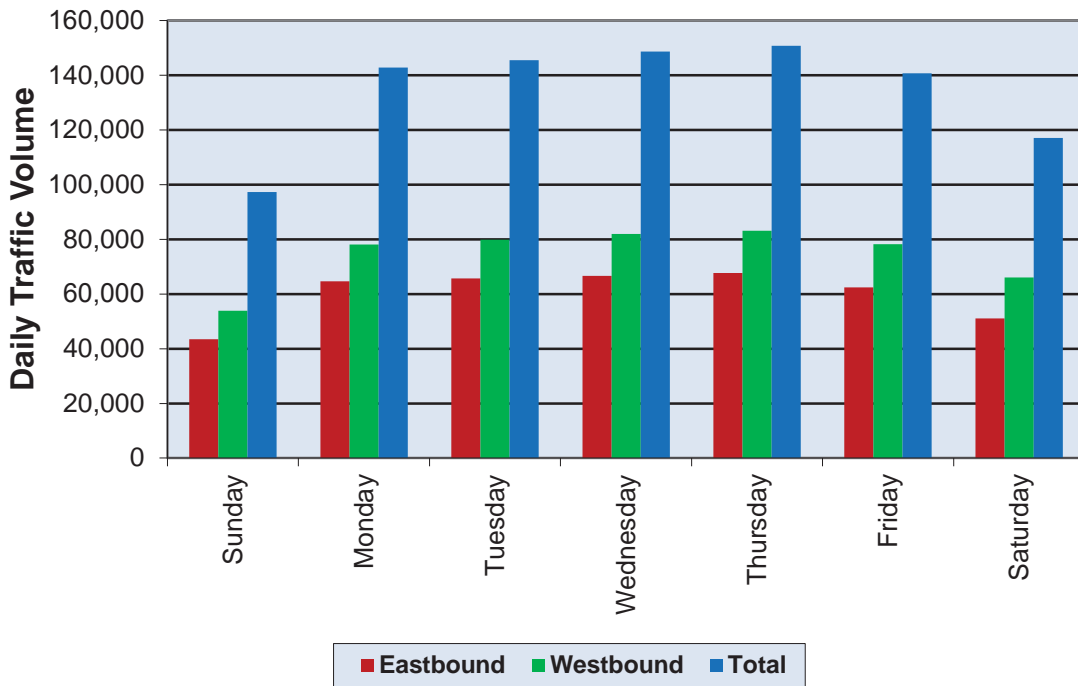

Day	Expressway Traffic Volumes		
	Eastbound	Westbound	Total
Sunday	43,520	53,830	97,350
Monday	64,700	78,130	142,830
Tuesday	65,660	79,830	145,490
Wednesday	66,680	81,980	148,660
Thursday	67,700	83,120	150,820
Friday	62,460	78,210	140,670
Saturday	51,110	66,020	117,130

Conway Mainline Toll Facility
SR 408 - East-West Expressway
Average Five Day Hourly Traffic - April 2017

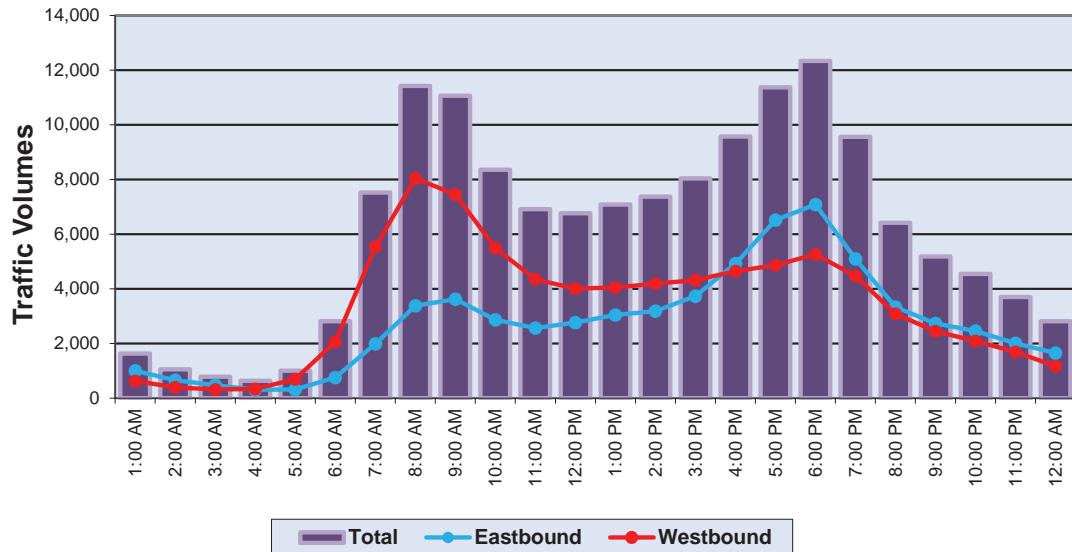

Hour Ending	Average Weekday Volumes		
	Eastbound	Westbound	Total
1:00 AM	1,000	628	1,628
2:00 AM	656	392	1,048
3:00 AM	475	312	787
4:00 AM	304	334	638
5:00 AM	312	694	1,006
6:00 AM	757	2,055	2,812
7:00 AM	1,988	5,536	7,524
8:00 AM	3,379	8,038	11,417
9:00 AM	3,617	7,450	11,067
10:00 AM	2,867	5,486	8,353
11:00 AM	2,562	4,346	6,908
12:00 PM	2,763	4,002	6,765

Hour Ending	Average Weekday Volumes		
	Eastbound	Westbound	Total
1:00 PM	3,040	4,043	7,083
2:00 PM	3,183	4,191	7,374
3:00 PM	3,725	4,315	8,040
4:00 PM	4,921	4,647	9,568
5:00 PM	6,511	4,861	11,372
6:00 PM	7,081	5,260	12,341
7:00 PM	5,094	4,462	9,556
8:00 PM	3,335	3,084	6,419
9:00 PM	2,737	2,448	5,185
10:00 PM	2,452	2,088	4,540
11:00 PM	2,008	1,687	3,695
12:00 AM	1,644	1,171	2,815

Total Eastbound	66,411
Total Westbound	81,530
Total Weekday	147,941

Conway Mainline Toll Facility
SR 408 - East-West Expressway
 Average Seven Day Hourly Traffic - April 2017

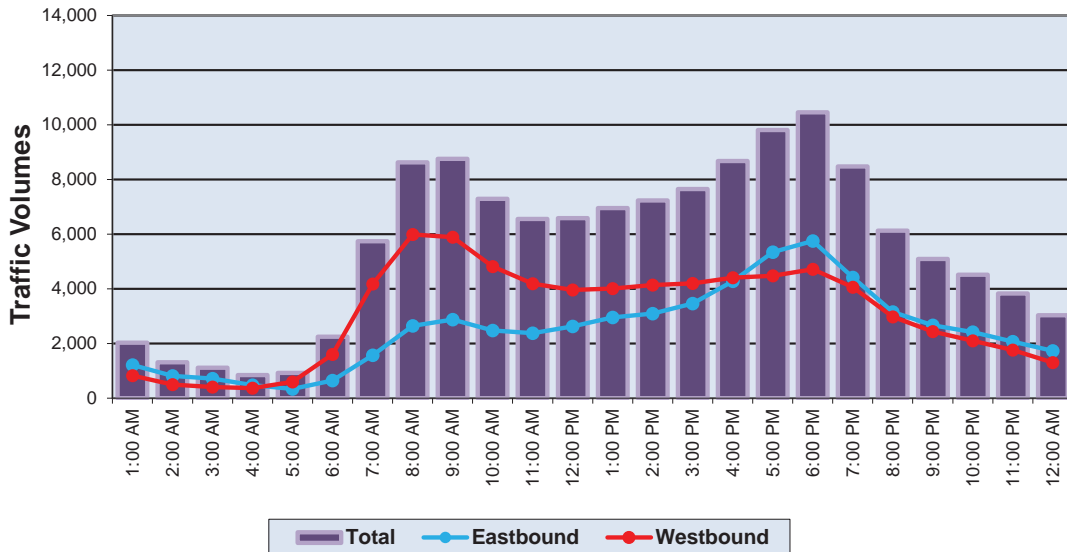

Hour Ending	Average Weekday Volumes		
	Eastbound	Westbound	Total
1:00 AM	1,209	819	2,028
2:00 AM	816	489	1,305
3:00 AM	709	401	1,111
4:00 AM	475	362	837
5:00 AM	332	590	922
6:00 AM	643	1,603	2,246
7:00 AM	1,566	4,171	5,737
8:00 AM	2,639	5,988	8,627
9:00 AM	2,871	5,884	8,755
10:00 AM	2,472	4,816	7,288
11:00 AM	2,372	4,184	6,557
12:00 PM	2,622	3,959	6,582

Hour Ending	Average Weekday Volumes		
	Eastbound	Westbound	Total
1:00 PM	2,951	4,004	6,955
2:00 PM	3,093	4,136	7,229
3:00 PM	3,461	4,192	7,653
4:00 PM	4,276	4,402	8,677
5:00 PM	5,338	4,473	9,810
6:00 PM	5,746	4,709	10,456
7:00 PM	4,415	4,059	8,474
8:00 PM	3,155	2,969	6,124
9:00 PM	2,662	2,431	5,093
10:00 PM	2,418	2,095	4,513
11:00 PM	2,071	1,755	3,825
12:00 AM	1,727	1,300	3,027

Total Eastbound	60,040
Total Westbound	73,792
Total Weekday	133,832

Conway Mainline Toll Facility

Toll Facility Peak Hour Characteristic Summary Typical Average Weekday (Monday through Friday) - April 2017

Average Weekday Traffic Summary (unadjusted)

Average Weekday Total Traffic	147,941
Eastbound Directional Traffic	66,411
Westbound Directional Traffic	81,530

Morning Peak Hour Summary (7:00 a.m. to 8:00 a.m.)

Eastbound Directional Traffic	3,379
Westbound Directional Traffic	8,038
Total AM Peak Hour Traffic	11,417

AM Peak Hour Factor ("K") = Total Peak Hour Traffic / Average Weekday Total Traffic

AM Peak Hour Factor ("K_{am}") 7.72%

AM Peak Hour Directional Factor ("D") = Peak Directional Traffic / Total Peak Hour Traffic

AM Peak Hour Directional Factor ("D_{am}") 70.40%

Evening Peak Hour Summary (5:00 p.m. to 6:00 p.m.)

Eastbound Directional Traffic	7,081
Westbound Directional Traffic	5,260
Total PM Peak Hour Traffic	12,341

PM Peak Hour Factor ("K") = Total Peak Hour Traffic / Average Weekday Total Traffic

PM Peak Hour Factor ("K_{pm}") 8.34%

PM Peak Hour Directional Factor ("D") = Peak Directional Traffic / Total Peak Hour Traffic

PM Peak Hour Directional Factor ("D_{pm}") 57.38%

Conway Mainline Toll Facility

Toll Transaction Summary

Typical Average Weekday (Monday through Friday) - April 2017

Average Weekday Summary

Direction of Travel	E-PASS (AVI)		ACM (Coin)		Manual (Cash)		Total	
	Volume	% Usage	Volume	% Usage	Volume	% Usage	Traffic	% Usage
Eastbound	59,992	90%	2,052	3%	4,367	7%	66,411	100%
Westbound	73,778	90%	2,105	3%	5,647	7%	81,530	100%

Morning Peak Hour Summary (7:00 a.m. to 8:00 a.m.)

Direction of Travel	E-PASS (AVI)		ACM (Coin)		Manual (Cash)		Total	
	Volume	% Usage	Volume	% Usage	Volume	% Usage	Traffic	% Usage
Eastbound	3,156	93%	52	2%	171	5%	3,379	100%
Westbound	7,486	93%	256	3%	296	4%	8,038	100%

Evening Peak Hour Summary (5:00 p.m. to 6:00 p.m.)

Direction of Travel	E-PASS (AVI)		ACM (Coin)		Manual (Cash)		Total	
	Volume	% Usage	Volume	% Usage	Volume	% Usage	Traffic	% Usage
Eastbound	5,980	84%	697	10%	404	6%	7,081	100%
Westbound	4,782	91%	106	2%	372	7%	5,260	100%

Conway Mainline Toll Facility
SR 408 - East West Expressway
Historical & Existing Total Transactions Statistics

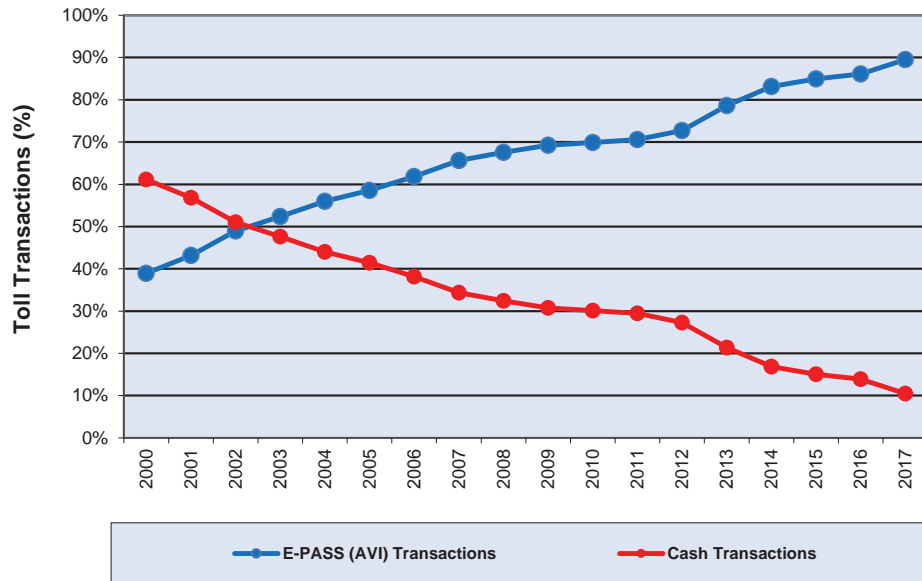

Year	Yearly Revenue Transaction		% Violations ⁽²⁾ (Percent of Total Transactions)
	% E-PASS (AVI) Transactions	% Cash Transactions	
2000	38.9%	61.1%	3.0%
2001	43.2%	56.8%	2.5%
2002	49.0%	51.0%	1.9%
2003	52.4%	47.6%	1.9%
2004	56.0%	44.0%	2.0%
2005	58.6%	41.4%	2.5%
2006	61.8%	38.2%	2.4%
2007	65.6%	34.4%	2.7%
2008	67.6%	32.4%	3.3%
2009	69.3%	30.7%	4.5%
2010	69.9%	30.1%	4.9%
2011	70.6%	29.4%	4.8%
2012	72.7%	27.3%	4.7%
2013	78.7%	21.3%	5.2%
2014	83.2%	16.8%	6.3%
2015	84.9%	15.1%	7.2%
2016	86.1%	13.9%	8.3%
2017	89.5%	10.5%	10.7%

1. All plazas had tolls suspended from 9/5/17 until 9/21/17 due to Hurricane Irma
 2. Calculated as percent of Total Transactions, which is equal to Revenue Transactions plus Violations

Dean Mainline Toll Facility (East-West Expressway)



2017 Traffic Data and Statistics Manual
CENTRAL FLORIDA EXPRESSWAY AUTHORITY

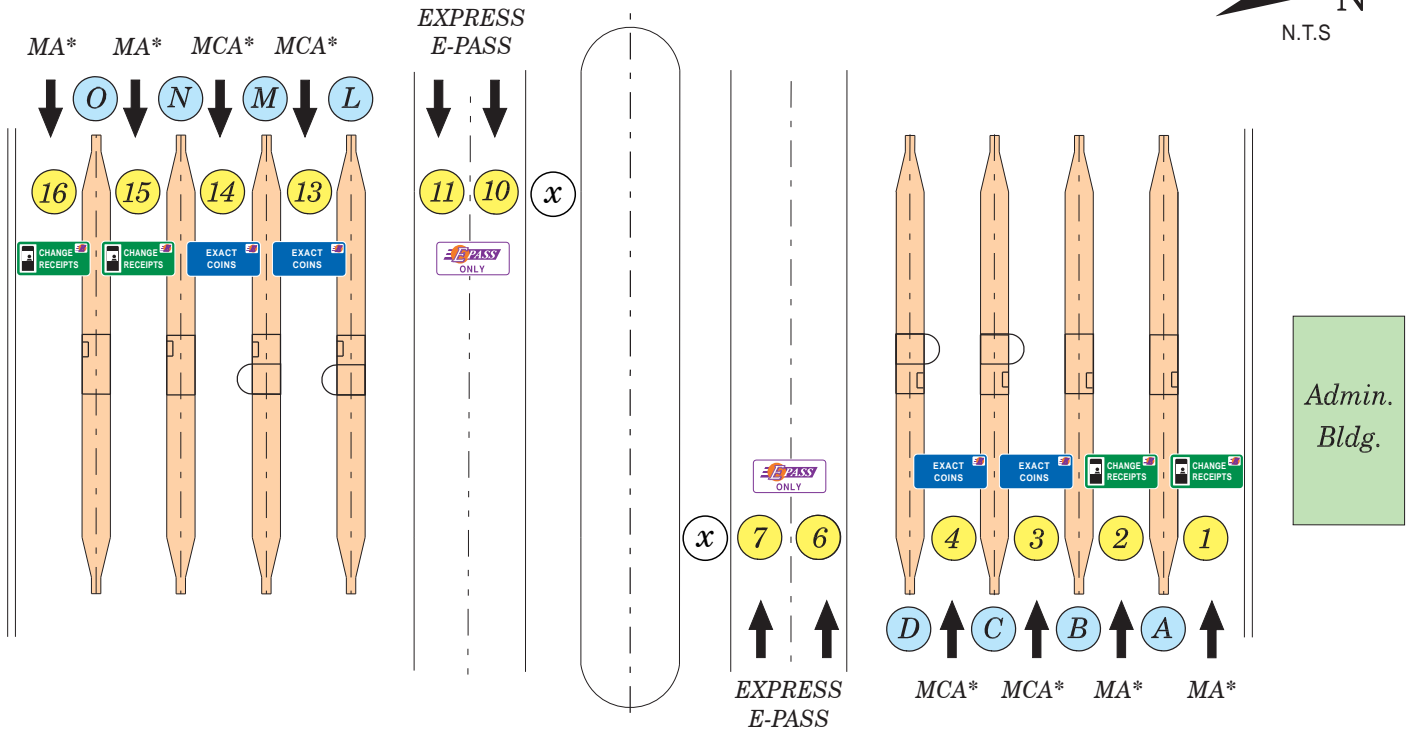

HISTORIC TRAFFIC - A.A.W.T.

1992	13,680 (POST-TOLL)	2015	74,180
1993	14,740	2016	79,580
1994	16,380	2016	83,570
1995	20,410		
1996	22,770		
1997	26,360		
1998	31,630		
1999	38,530		
2000	45,800		
2001	50,100		
2002	53,760		
2003	57,600		
2004	63,930		
2005	65,900		
2006	69,900		
2007	70,100		
2008	66,000		
2009	65,900 (Toll Increase April 2009)		
2010	68,130		
2011	66,670		
2012	67,200 (Toll Increase July 2012)		
2013	67,320		
2014	71,110		

TOLL RATE STRUCTURE **

	<u>E-PASS</u>	<u>CASH</u>
2 Axles	\$.82	\$ 1.00
3 Axles	\$ 1.64	\$ 1.75
4 Axles	\$ 1.91	\$ 2.00
5 Axles or more	\$ 2.46	\$ 2.50

LANES OF EQUIPMENT

- 4 Express E-PASS (E-PASS only)
- 4 Booths with Automatic Coin Machines with E-PASS (MCA)
- 4 Manned Booths with E-PASS (MA)
- * Changeable Message Sign

LEGEND

- ① Lane Number
- Ⓐ Island Designation
- ⓧ Under Construction by Project #408-128

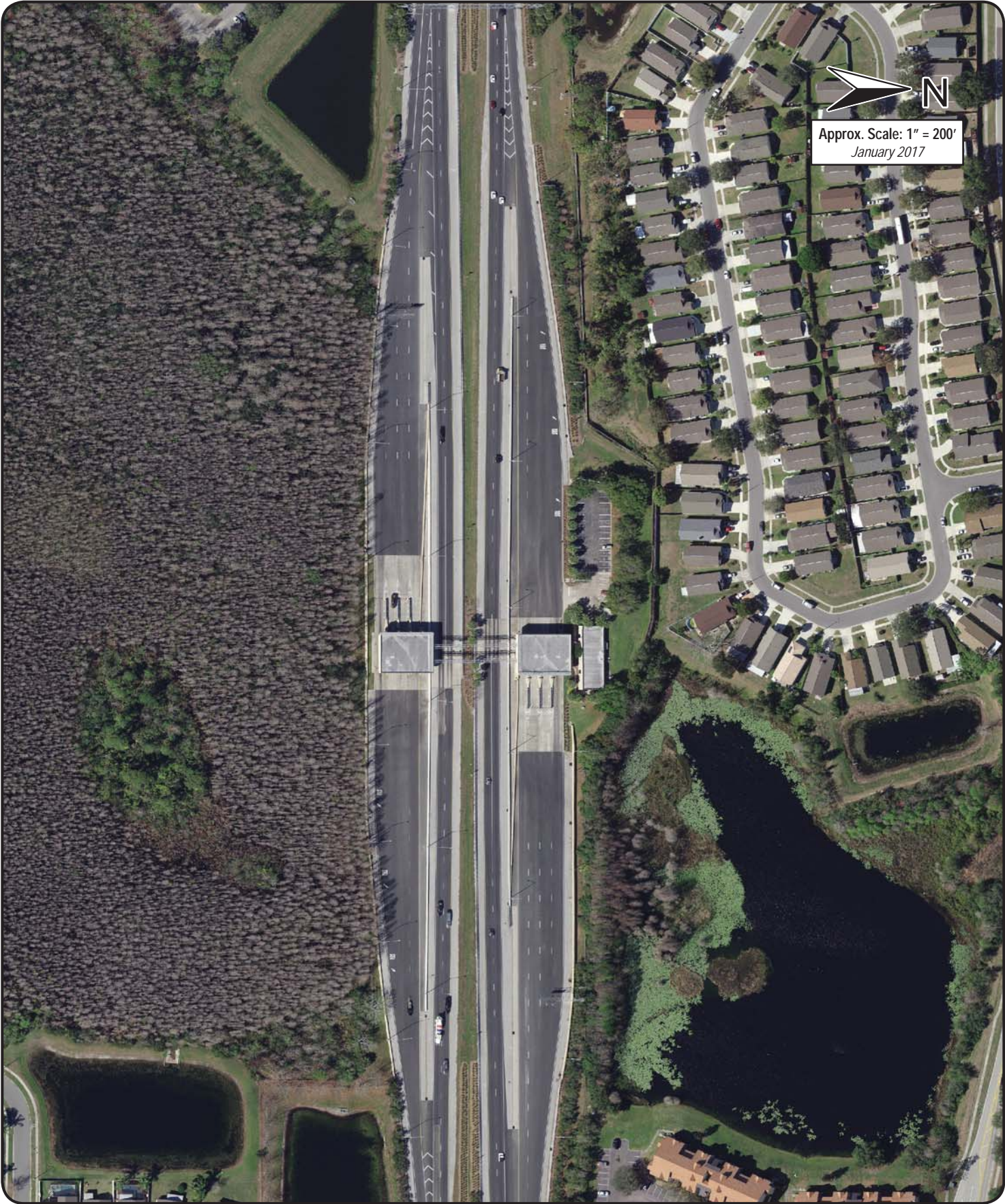

Approx. Scale: 1" = 200'
January 2017

Dean Mainline Toll Facility SR 408 - East-West Expressway

Fiscal Year 2017 Monthly Mainline & Ramp Toll Transactions and Revenue Summary

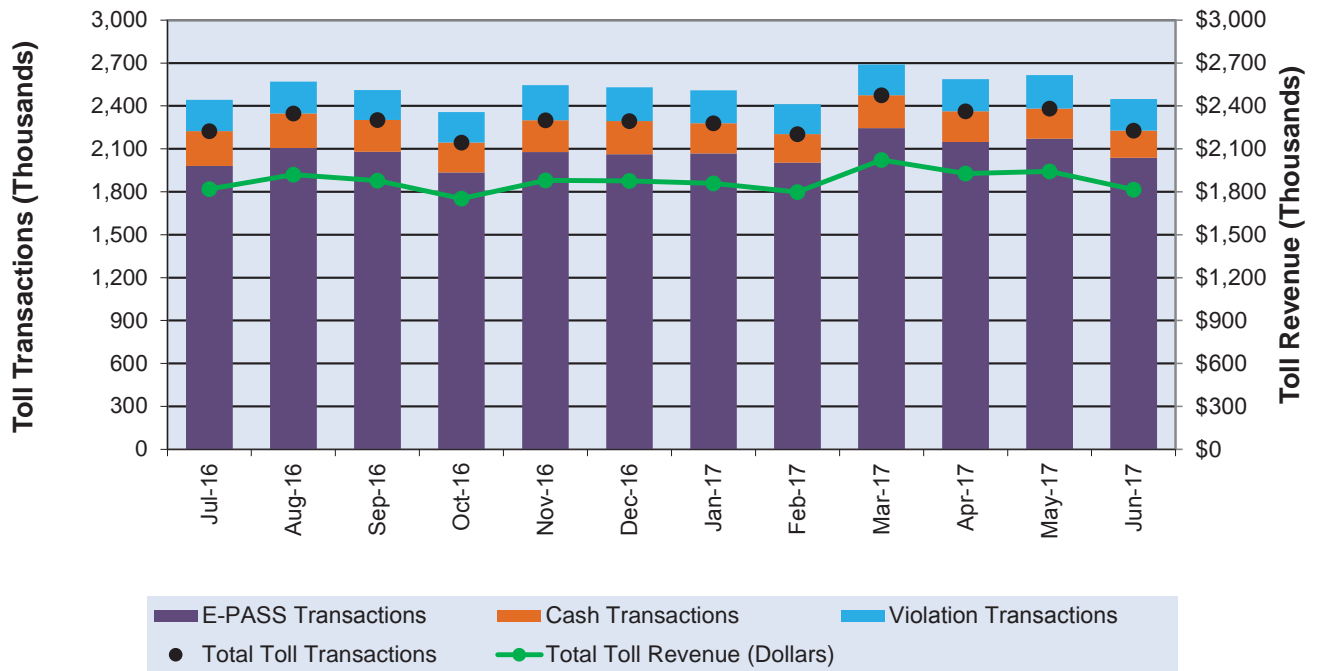

Month	FY 17 MONTHLY MAINLINE & RAMP TOLL TRANSACTIONS					Total Toll Revenue
	E-PASS	Cash	Total Revenue	Violations	Total	
July-16	1,980,920	242,643	2,223,563	219,583	2,443,146	\$1,819,329
August-16	2,106,722	240,985	2,347,707	221,207	2,568,914	\$1,919,344
September-16	2,080,018	221,405	2,301,423	210,097	2,511,520	\$1,878,540
October-16	1,934,923	209,100	2,144,023	212,634	2,356,657	\$1,752,791
November-16	2,076,904	223,149	2,300,053	244,841	2,544,894	\$1,878,951
December-16	2,061,304	233,611	2,294,915	235,601	2,530,516	\$1,875,793
January-17	2,067,605	211,113	2,278,718	229,737	2,508,455	\$1,859,732
February-17	2,002,622	199,912	2,202,534	209,066	2,411,600	\$1,798,295
March-17	2,244,581	229,874	2,474,455	215,686	2,690,141	\$2,023,126
April-17	2,148,086	215,360	2,363,446	222,931	2,586,377	\$1,927,642
May-17	2,171,539	210,118	2,381,657	234,493	2,616,150	\$1,942,293
June-17	2,037,063	189,729	2,226,792	221,314	2,448,106	\$1,815,676
Yearly Totals	24,912,287	2,626,999	27,539,286	2,677,190	30,216,476	\$22,491,512

Note: Data includes ramp toll plazas that report to the Dean Mainline Toll Plaza.

1. Cash transactions were calculated as the difference between total revenue traffic and E-PASS traffic
2. All plazas had tolls suspended in FY 17 due to Hurricane Matthew from 10/5/16 until early on 10/10/16

Dean Mainline Toll Facility
SR 408 - East-West Expressway
Typical Daily Traffic Volumes - April 2017

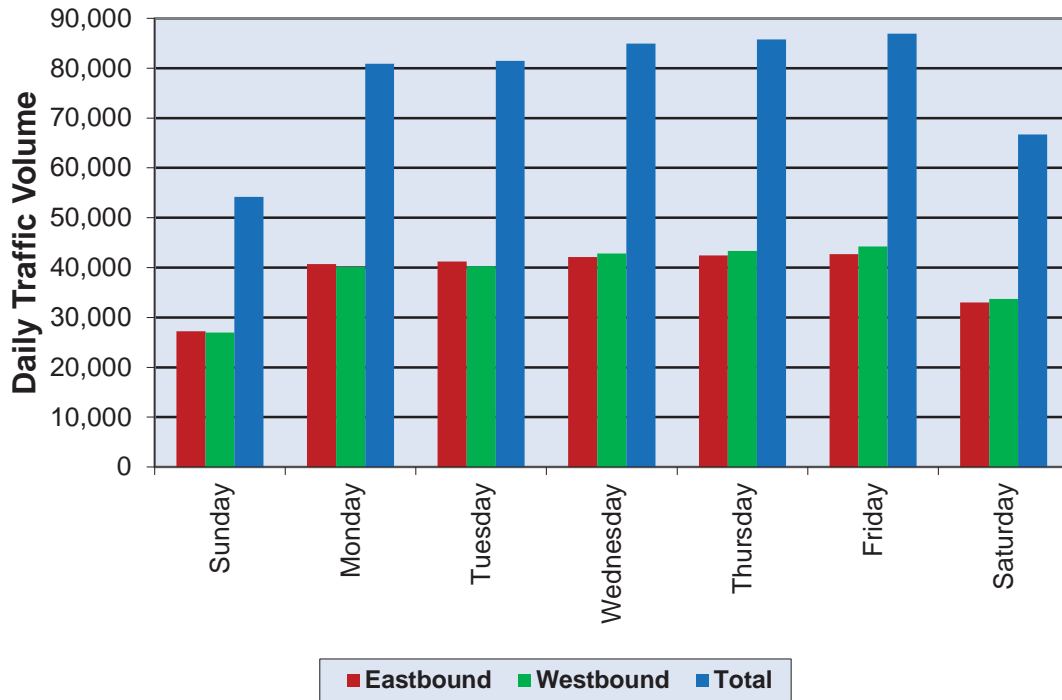

Day	Expressway Traffic Volumes		
	Eastbound	Westbound	Total
Sunday	27,220	26,980	54,200
Monday	40,740	40,130	80,870
Tuesday	41,230	40,230	81,460
Wednesday	42,140	42,810	84,950
Thursday	42,420	43,360	85,780
Friday	42,670	44,260	86,930
Saturday	33,020	33,710	66,730

Dean Mainline Toll Facility
SR 408 - East-West Expressway
 Average Five Day Hourly Traffic - April 2017

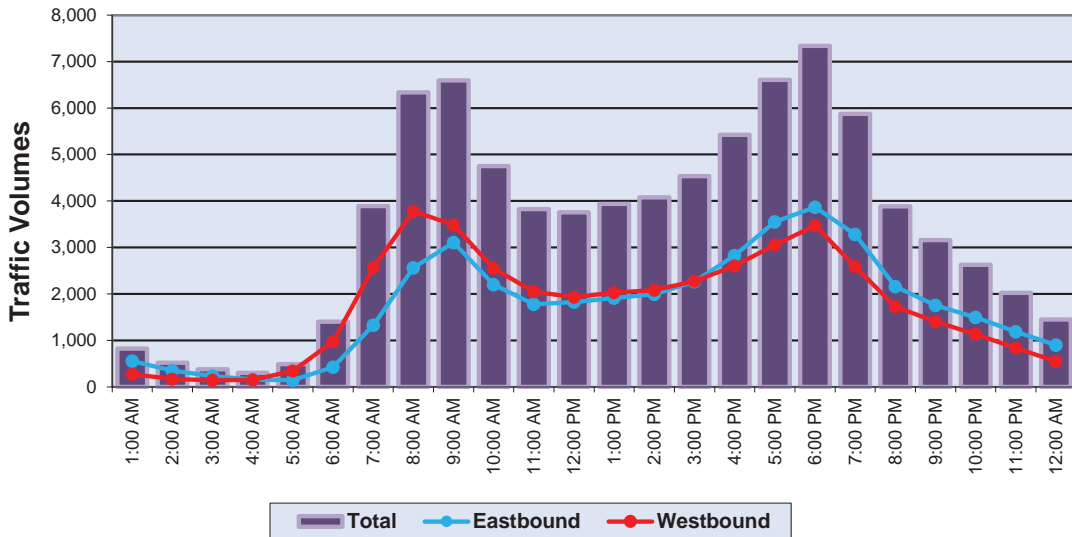

Hour Ending	Average Weekday Volumes		
	Eastbound	Westbound	Total
1:00 AM	553	272	825
2:00 AM	351	166	517
3:00 AM	234	145	379
4:00 AM	154	150	304
5:00 AM	146	343	489
6:00 AM	427	978	1,405
7:00 AM	1,326	2,565	3,891
8:00 AM	2,561	3,778	6,339
9:00 AM	3,108	3,489	6,597
10:00 AM	2,200	2,552	4,752
11:00 AM	1,779	2,047	3,826
12:00 PM	1,827	1,927	3,754

Hour Ending	Average Weekday Volumes		
	Eastbound	Westbound	Total
1:00 PM	1,911	2,028	3,939
2:00 PM	1,995	2,083	4,078
3:00 PM	2,261	2,274	4,535
4:00 PM	2,825	2,600	5,425
5:00 PM	3,549	3,056	6,605
6:00 PM	3,865	3,471	7,336
7:00 PM	3,280	2,593	5,873
8:00 PM	2,157	1,727	3,884
9:00 PM	1,756	1,400	3,156
10:00 PM	1,494	1,133	2,627
11:00 PM	1,188	837	2,025
12:00 AM	900	549	1,449

Total Eastbound	41,847
Total Westbound	42,163
Total Weekday	84,010

Dean Mainline Toll Facility
SR 408 - East-West Expressway
Average Seven Day Hourly Traffic - April 2017

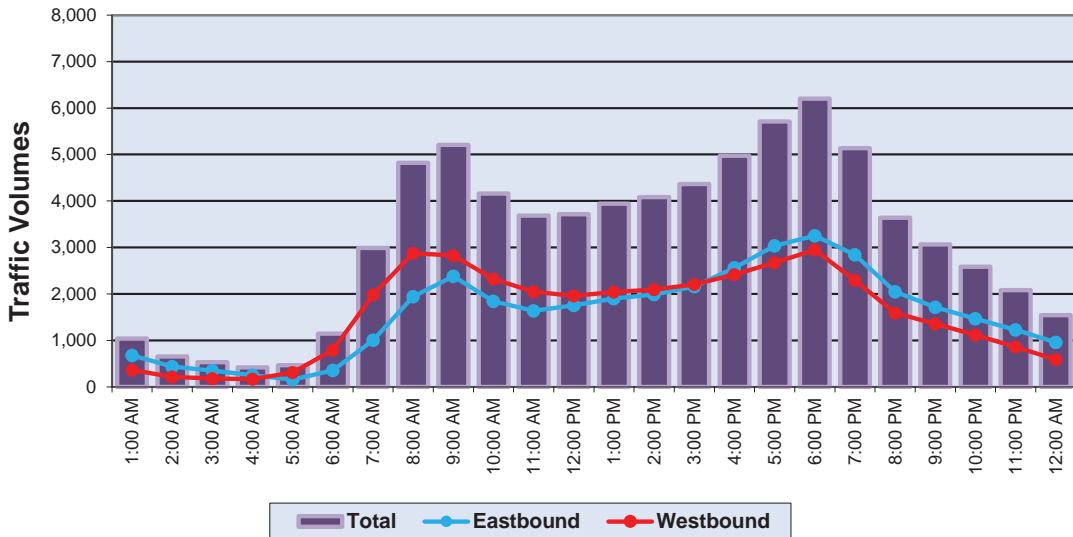

Hour Ending	Average Weekday Volumes		
	Eastbound	Westbound	Total
1:00 AM	678	361	1,038
2:00 AM	439	212	651
3:00 AM	351	181	532
4:00 AM	248	169	417
5:00 AM	158	307	465
6:00 AM	354	793	1,147
7:00 AM	1,004	1,984	2,988
8:00 AM	1,941	2,880	4,821
9:00 AM	2,380	2,826	5,206
10:00 AM	1,839	2,322	4,161
11:00 AM	1,640	2,048	3,687
12:00 PM	1,754	1,962	3,716

Hour Ending	Average Weekday Volumes		
	Eastbound	Westbound	Total
1:00 PM	678	361	1,038
2:00 PM	439	212	651
3:00 PM	351	181	532
4:00 PM	248	169	417
5:00 PM	158	307	465
6:00 PM	354	793	1,147
7:00 PM	1,004	1,984	2,988
8:00 PM	1,941	2,880	4,821
9:00 PM	2,380	2,826	5,206
10:00 PM	1,839	2,322	4,161
11:00 PM	1,640	2,048	3,687
12:00 AM	1,754	1,962	3,716

Total Eastbound	37,935
Total Westbound	38,221
Total Weekday	76,156

Dean Mainline Toll Facility

Toll Transaction Summary

Typical Average Weekday (Monday through Friday) - April 2017

Average Weekday Summary

Direction of Travel	E-PASS (AVI)		ACM (Coin)		Manual (Cash)		Total	
	Volume	% Usage	Volume	% Usage	Volume	% Usage	Traffic	% Usage
Eastbound	38,791	93%	777	2%	2,279	5%	41,847	100%
Westbound	38,718	92%	891	2%	2,554	6%	42,163	100%

Morning Peak Hour Summary (7:00 a.m. to 8:00 a.m.)

Direction of Travel	E-PASS (AVI)		ACM (Coin)		Manual (Cash)		Total	
	Volume	% Usage	Volume	% Usage	Volume	% Usage	Traffic	% Usage
Eastbound	2,932	94%	44	1%	132	4%	3,108	100%
Westbound	3,277	94%	56	2%	156	4%	3,489	100%

Evening Peak Hour Summary (5:00 p.m. to 6:00 p.m.)

Direction of Travel	E-PASS (AVI)		ACM (Coin)		Manual (Cash)		Total	
	Volume	% Usage	Volume	% Usage	Volume	% Usage	Traffic	% Usage
Eastbound	3,635	94%	62	2%	168	4%	3,865	100%
Westbound	3,227	93%	62	2%	182	5%	3,471	100%

Dean Mainline Toll Facility
SR 408 - East-West Expressway
Historical & Existing Total Revenue Transactions Statistics

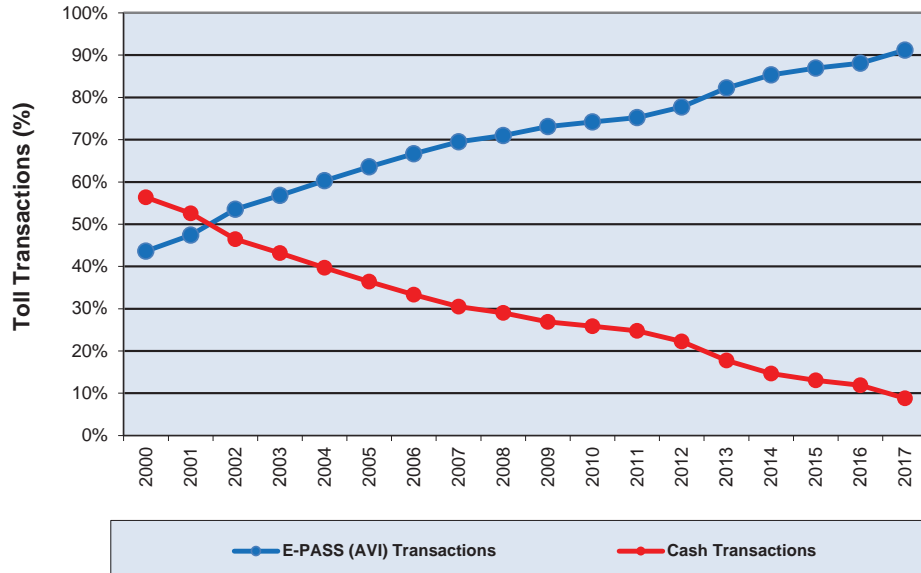

Year	Yearly Revenue Transaction		% Violations ⁽²⁾ (Percent of Total Transactions)
	% E-PASS (AVI) Transactions	% Cash Transactions	
2000	43.7%	56.3%	1.9%
2001	47.4%	52.6%	1.7%
2002	53.5%	46.5%	1.5%
2003	56.8%	43.2%	1.3%
2004	60.3%	39.7%	1.6%
2005	63.6%	36.4%	2.8%
2006	66.7%	33.3%	2.4%
2007	69.5%	30.5%	2.4%
2008	71.0%	29.0%	2.4%
2009	73.1%	26.9%	3.3%
2010	74.2%	25.8%	3.7%
2011	75.2%	24.8%	3.7%
2012	77.8%	22.2%	4.0%
2013	82.2%	17.8%	4.7%
2014	85.3%	14.7%	5.5%
2015	87.0%	13.0%	6.4%
2016	88.1%	11.9%	7.3%
2017	91.2%	8.8%	9.6%

1. All plazas had tolls suspended from 9/5/17 until 9/21/17 due to Hurricane Irma

2. Calculated as percent of Total Transactions, which is equal to Revenue Transactions plus Violations

Beachline Mainline Toll Facility (Beachline Expressway)



2017 Traffic Data and Statistics Manual
CENTRAL FLORIDA EXPRESSWAY AUTHORITY

OSCEOLA



Admin.
Blg.

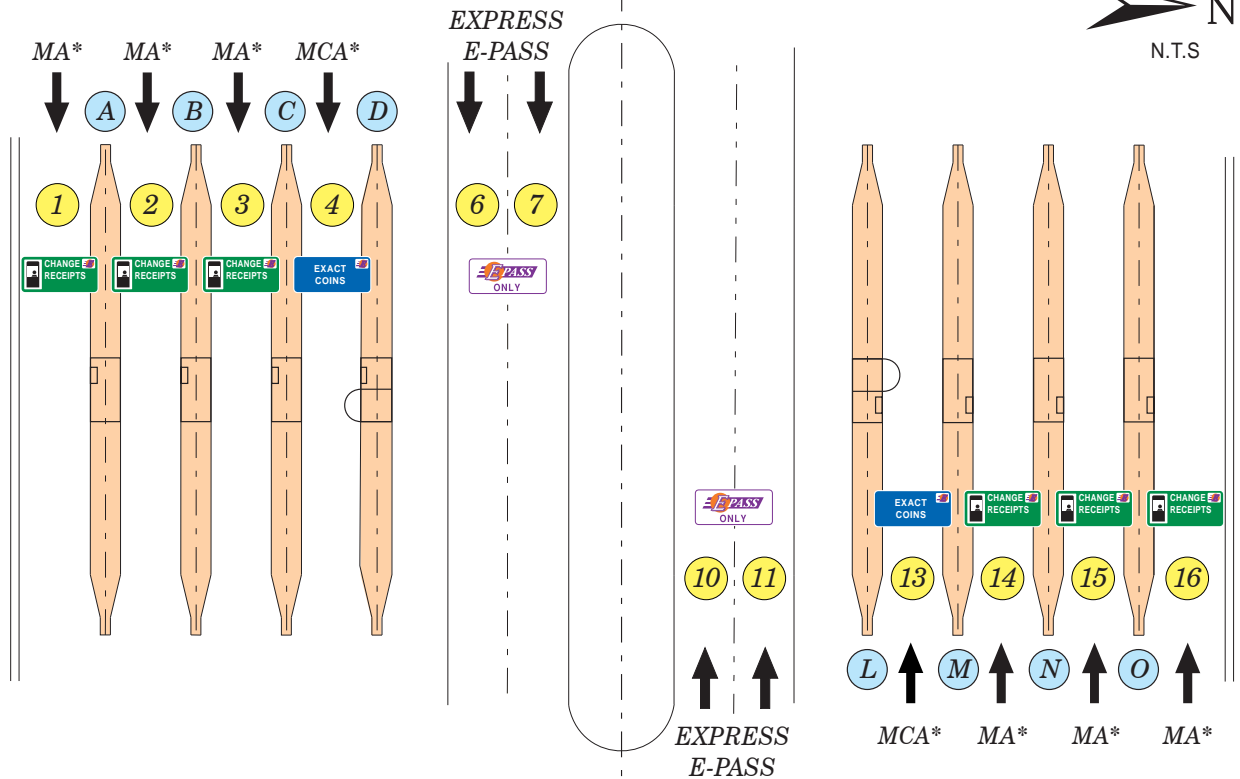

HISTORIC TRAFFIC - A.A.W.T.

1992	18,630 (POST-TOLL)	2015	56,120
1993	21,090	2016	60,710
1994	21,800	2017	65,540
1995	22,130		
1996	23,920		
1997	25,520		
1998	29,420		
1999	29,970		
2000	33,590		
2001	34,590		
2002	36,760		
2003	39,940		
2004	45,930		
2005	46,000		
2006	46,300		
2007	47,700		
2008	42,500		
2009	43,300 (Toll Increase April 2009)		
2010	46,300		
2011	46,880		
2012	48,430 (Toll Increase July 2012)		
2013	49,230		
2014	53,510		

TOLL RATE STRUCTURE **

	<u>E-PASS</u>	<u>CASH</u>
2 Axles	\$.87	\$ 1.00
3 Axles	\$ 1.71	\$ 1.75
4 Axles	\$ 2.00	\$ 2.00
5 Axles or more	\$ 2.55	\$ 2.50

LANES OF EQUIPMENT

- 6 Manned Booths with E-PASS (MA)
- 2 Booths with ACM's and E-PASS
- 4 Express E-PASS (E-PASS only)

* Changeable Message Sign

** \$0.25 of toll paid to FDOT for removed FDOT plaza.

LEGEND

- ① Lane Number
- Ⓐ Island Designation



Approx. Scale: 1" = 200'
January 2017

Beachline Mainline Toll Facility

SR 528 - Beachline Expressway

Fiscal Year 2017 Monthly Mainline & Ramp Toll Transactions and Revenue Summary

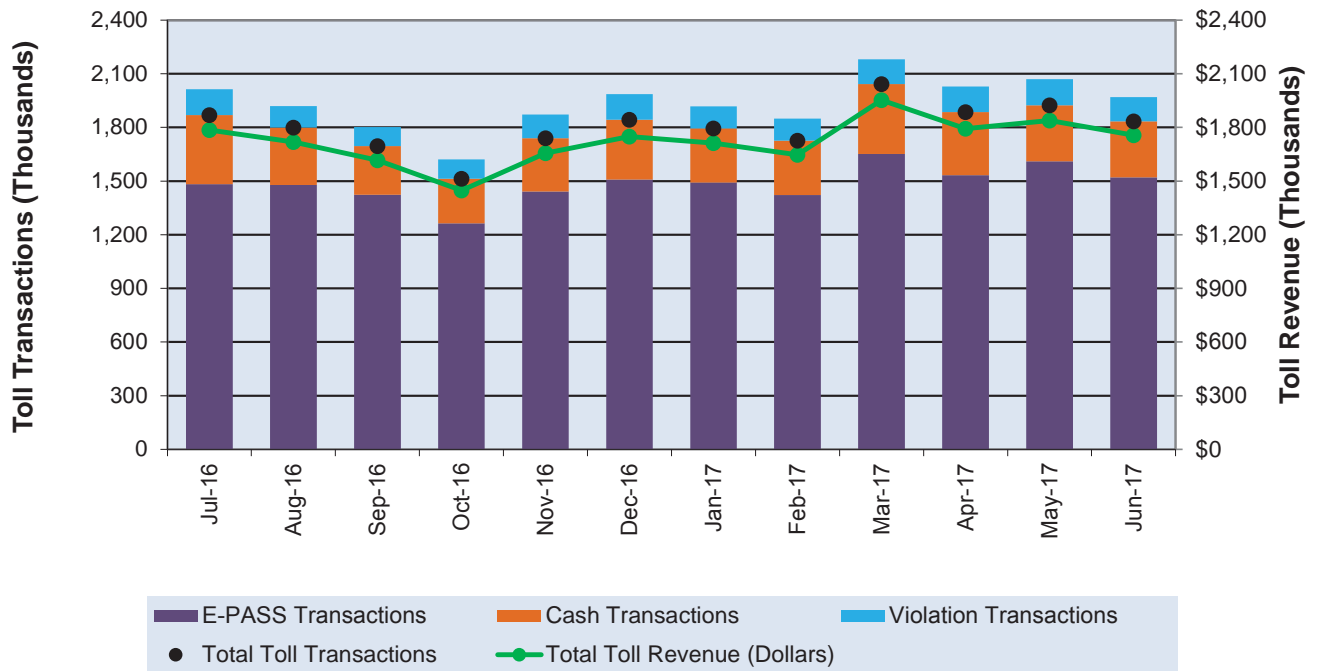

Month	FY 17 MONTHLY MAINLINE & RAMP TOLL TRANSACTIONS					Total Toll Revenue
	E-PASS	Cash	Total Revenue	Violations	Total	
July-16	1,481,969	386,124	1,868,093	145,140	2,013,233	\$1,785,848
August-16	1,477,677	321,096	1,798,773	119,777	1,918,550	\$1,718,943
September-16	1,422,931	271,844	1,694,775	107,843	1,802,618	\$1,615,832
October-16	1,263,504	249,838	1,513,342	107,138	1,620,480	\$1,447,258
November-16	1,442,133	296,923	1,739,056	132,050	1,871,106	\$1,656,075
December-16	1,508,389	334,811	1,843,200	142,454	1,985,654	\$1,748,348
January-17	1,490,968	303,554	1,794,522	123,475	1,917,997	\$1,711,872
February-17	1,421,174	305,095	1,726,269	122,478	1,848,747	\$1,647,515
March-17	1,650,938	391,307	2,042,245	138,923	2,181,168	\$1,952,804
April-17	1,532,526	352,943	1,885,469	142,743	2,028,212	\$1,793,387
May-17	1,610,486	312,739	1,923,225	145,717	2,068,942	\$1,837,829
June-17	1,521,168	312,661	1,833,829	135,644	1,969,473	\$1,756,148
Yearly Totals	17,823,863	3,838,935	21,662,798	1,563,382	23,226,180	\$20,671,859

Note: Data includes ramp toll plazas that report to the Beachline Mainline Toll Plaza.

1. Cash transactions were calculated as the difference between total revenue traffic and E-PASS traffic
2. All plazas had tolls suspended in FY 17 due to Hurricane Matthew from 10/5/16 until early on 10/10/16



Beachline Mainline Toll Facility
SR 528 - Beachline Expressway
Typical Daily Expressway Traffic Volumes - April 2017

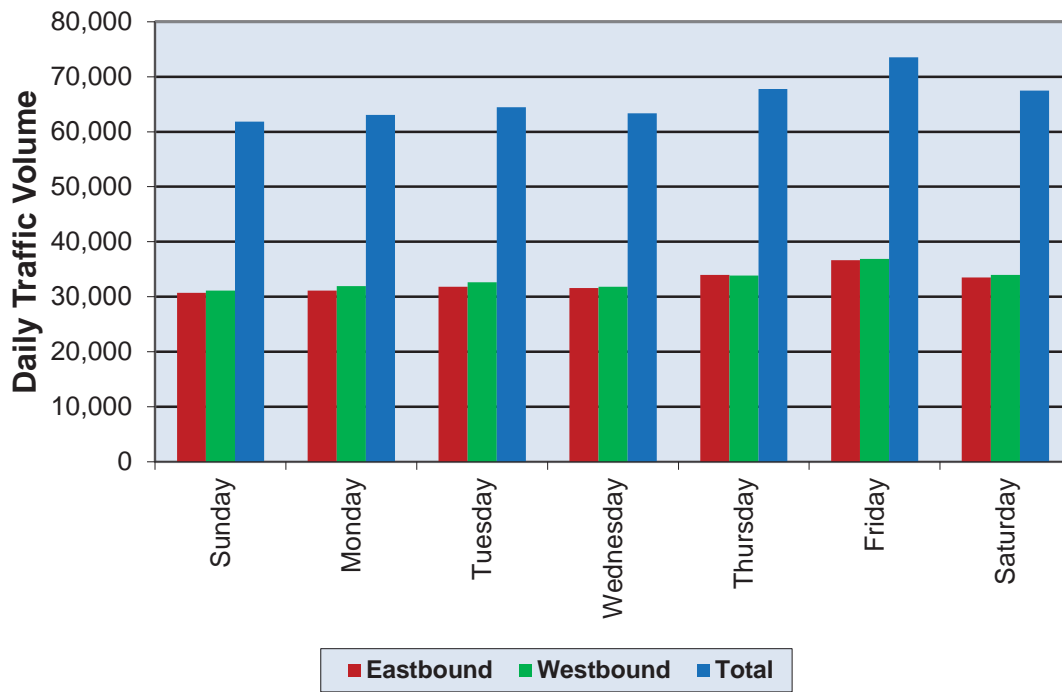

Day	Expressway Traffic Volumes		
	Eastbound	Westbound	Total
Sunday	30,730	31,100	61,830
Monday	31,100	31,950	63,050
Tuesday	31,810	32,640	64,450
Wednesday	31,580	31,790	63,370
Thursday	33,940	33,830	67,770
Friday	36,640	36,860	73,500
Saturday	33,490	33,970	67,460

Beachline Mainline Toll Facility
SR 528 - Beachline Expressway
 Typical Average Five Day Hourly Traffic - April 2017

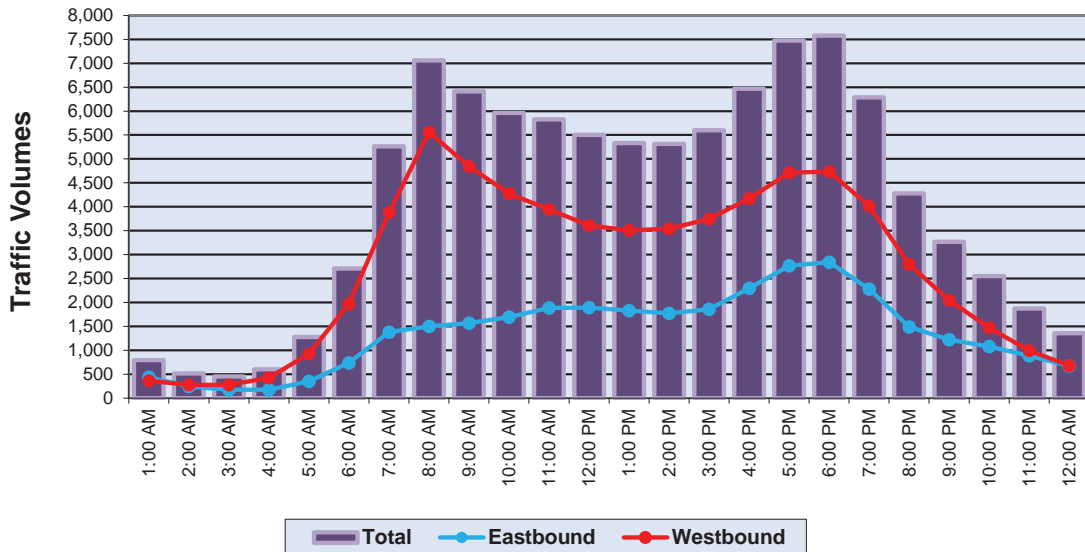

Hour Ending	Average Weekday Volumes		
	Eastbound	Westbound	Total
1:00 AM	434	359	793
2:00 AM	242	275	517
3:00 AM	172	278	450
4:00 AM	172	427	599
5:00 AM	352	923	1,275
6:00 AM	739	1,970	2,709
7:00 AM	1,379	3,883	5,262
8:00 AM	1,500	5,561	7,061
9:00 AM	1,567	4,845	6,412
10:00 AM	1,690	4,274	5,964
11:00 AM	1,886	3,942	5,828
12:00 PM	1,891	3,611	5,502

Hour Ending	Average Weekday Volumes		
	Eastbound	Westbound	Total
1:00 PM	1,827	3,505	5,332
2:00 PM	1,775	3,540	5,315
3:00 PM	1,858	3,743	5,601
4:00 PM	2,297	4,173	6,470
5:00 PM	2,765	4,713	7,478
6:00 PM	2,843	4,734	7,577
7:00 PM	2,277	4,012	6,289
8:00 PM	1,485	2,795	4,280
9:00 PM	1,221	2,044	3,265
10:00 PM	1,081	1,471	2,552
11:00 PM	883	994	1,877
12:00 AM	676	682	1,358

Total Eastbound	33,012
Total Westbound	37,747
Total Weekday	70,759

Beachline Mainline Toll Facility
SR 528 - Beachline Expressway
 Typical Average Seven Day Hourly Traffic - April 2017

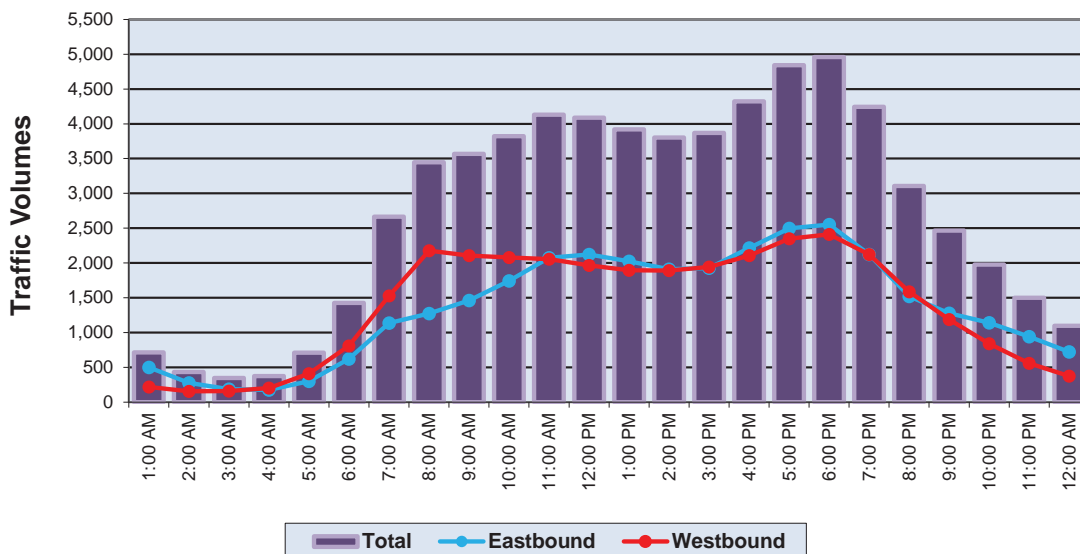

Hour Ending	Average Weekday Volumes			Hour Ending	Average Weekday Volumes		
	Eastbound	Westbound	Total		Eastbound	Westbound	Total
1:00 AM	498	217	716	1:00 PM	2,025	1,895	3,921
2:00 AM	276	155	431	2:00 PM	1,910	1,893	3,803
3:00 AM	186	159	346	3:00 PM	1,927	1,943	3,870
4:00 AM	173	201	374	4:00 PM	2,214	2,107	4,321
5:00 AM	299	411	710	5:00 PM	2,496	2,346	4,842
6:00 AM	620	806	1,426	6:00 PM	2,552	2,409	4,961
7:00 AM	1,138	1,527	2,665	7:00 PM	2,123	2,122	4,245
8:00 AM	1,272	2,176	3,448	8:00 PM	1,521	1,585	3,106
9:00 AM	1,461	2,108	3,569	9:00 PM	1,277	1,188	2,464
10:00 AM	1,744	2,079	3,822	10:00 PM	1,139	840	1,978
11:00 AM	2,075	2,056	4,131	11:00 PM	940	559	1,498
12:00 PM	2,123	1,965	4,088	12:00 AM	721	375	1,097

Total Eastbound	32,712
Total Westbound	33,121
Total Weekday	65,833

Beachline Mainline Toll Facility

Toll Facility Peak Hour Characteristic Summary Typical Average Weekday (Monday through Friday) - April 2017

Average Weekday Traffic Summary (unadjusted)

Average Weekday Total Traffic	70,759
Eastbound Directional Traffic	33,012
Westbound Directional Traffic	37,747

Morning Peak Hour Summary (7:00 a.m. to 8:00 a.m.)

Eastbound Directional Traffic	1,500
Westbound Directional Traffic	2,948
Total AM Peak Hour Traffic	4,448

AM Peak Hour Factor ("K") = Total Peak Hour Traffic / Average Weekday Total Traffic

AM Peak Hour Factor ("K_{am}") **6.29%**

AM Peak Hour Directional Factor ("D") = Peak Directional Traffic / Total Peak Hour Traffic

AM Peak Hour Directional Factor ("D_{am}") **66.28%**

Evening Peak Hour Summary (5:00 p.m. to 6:00 p.m.)

Eastbound Directional Traffic	2,843
Westbound Directional Traffic	4,734
Total PM Peak Hour Traffic	7,577

PM Peak Hour Factor ("K") = Total Peak Hour Traffic / Average Weekday Total Traffic

PM Peak Hour Factor ("K_{pm}") **7.59%**

PM Peak Hour Directional Factor ("D") = Peak Directional Traffic / Total Peak Hour Traffic

PM Peak Hour Directional Factor ("D_{pm}") **50.92%**

Beachline Mainline Toll Facility

Toll Transaction Summary

Typical Average Weekday (Monday through Friday) - April 2017

Average Weekday Summary

Direction of Travel	E-PASS (AVI)		ACM (Coin)		Manual (Cash)		Total	
	Volume	% Usage	Volume	% Usage	Volume	% Usage	Traffic	% Usage
Eastbound	27,442	83%	1,019	3%	4,551	14%	33,012	100%
Westbound	27,760	42%	1,171	2%	37,823	57%	66,754	100%

Morning Peak Hour Summary (7:00 a.m. to 8:00 a.m.)

Direction of Travel	E-PASS (AVI)		ACM (Coin)		Manual (Cash)		Total	
	Volume	% Usage	Volume	% Usage	Volume	% Usage	Traffic	% Usage
Eastbound	1,358	91%	20	1%	122	8%	1,500	100%
Westbound	2,561	46%	49	1%	2,951	53%	5,561	100%

Evening Peak Hour Summary (5:00 p.m. to 6:00 p.m.)

Direction of Travel	E-PASS (AVI)		ACM (Coin)		Manual (Cash)		Total	
	Volume	% Usage	Volume	% Usage	Volume	% Usage	Traffic	% Usage
Eastbound	2,504	88%	62	2%	277	10%	2,843	100%
Westbound	1,900	40%	88	2%	2,746	58%	4,734	100%

Beachline Mainline Toll Facility
SR 528 - Beachline Expressway
Historical & Existing Total Revenue Transactions Statistics

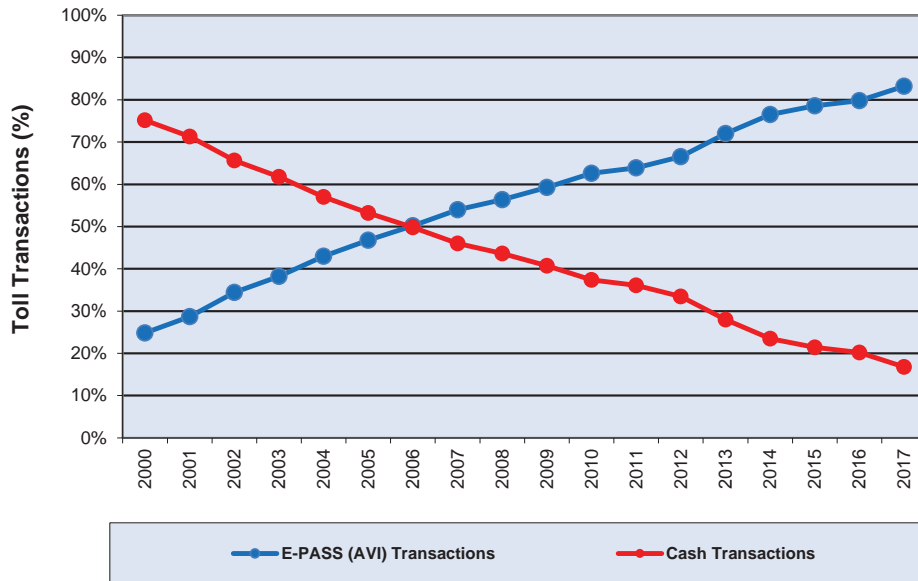

Year	Yearly Revenue Transaction		% Violations ⁽²⁾ (Percent of Total Transactions)
	% E-PASS (AVI) Transactions	% Cash Transactions	
2000	24.8%	75.2%	2.5%
2001	28.7%	71.3%	2.0%
2002	34.4%	65.6%	1.7%
2003	38.2%	61.8%	1.8%
2004	43.0%	57.0%	2.3%
2005	46.8%	53.2%	2.7%
2006	50.2%	49.8%	2.6%
2007	54.0%	46.0%	2.1%
2008	56.3%	43.7%	2.1%
2009	59.3%	40.7%	3.6%
2010	62.6%	37.4%	3.7%
2011	63.9%	36.1%	4.1%
2012	66.5%	33.5%	3.2%
2013	72.0%	28.0%	3.5%
2014	76.5%	23.5%	4.2%
2015	78.6%	21.4%	5.0%
2016	79.8%	20.2%	5.6%
2017	83.2%	16.8%	7.4%

1. All plazas had tolls suspended from 9/5/17 until 9/21/17 due to Hurricane Irma

2. Calculated as percent of Total Transactions, which is equal to Revenue Transactions plus Violations

Dallas Mainline Toll Facility (Beachline Expressway)



2017 Traffic Data and Statistics Manual
CENTRAL FLORIDA EXPRESSWAY AUTHORITY

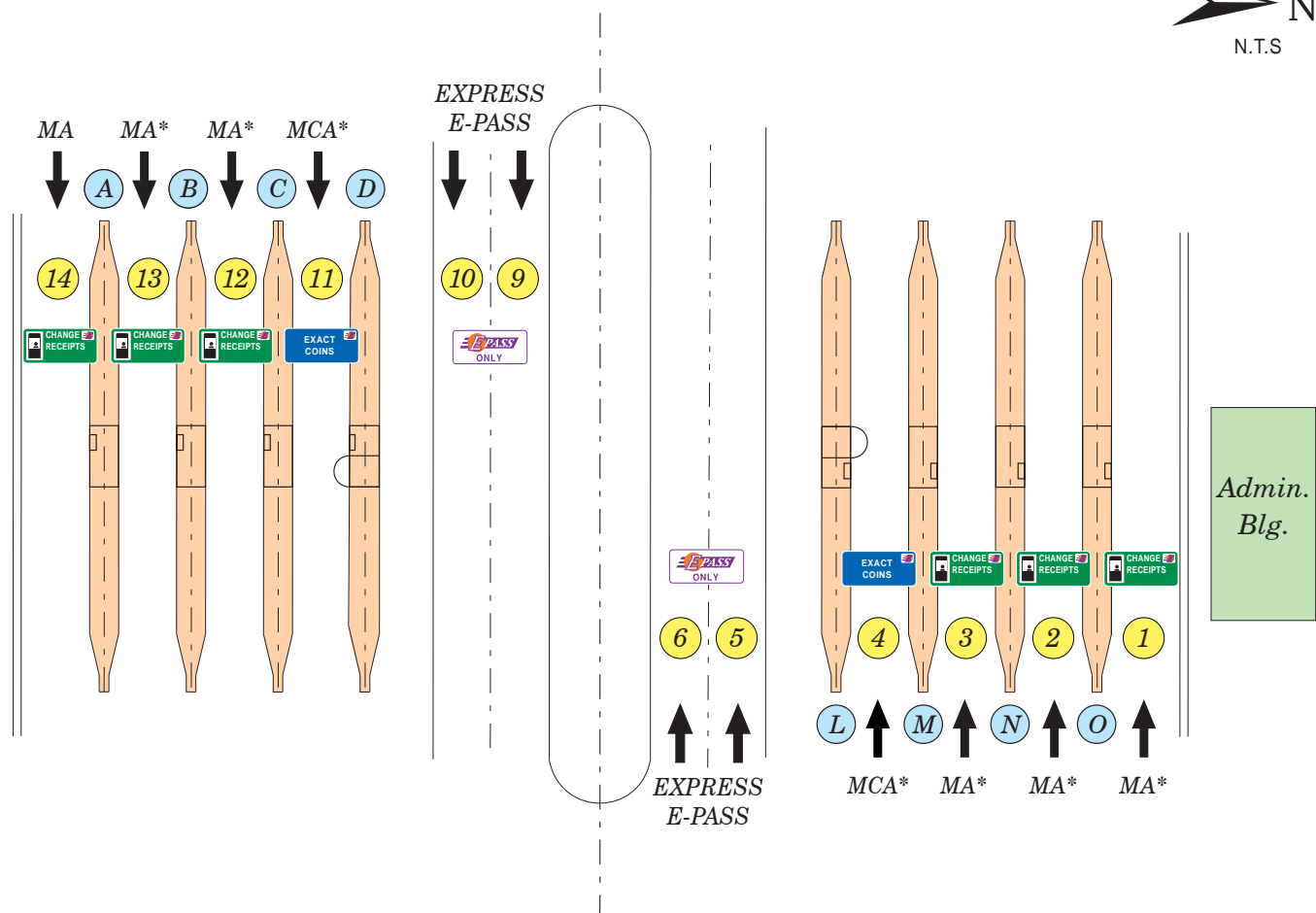

HISTORIC TRAFFIC - A.A.W.T.

2012	38,360
2013	39,190
2014	40,890
2015	45,530
2016	46,880
2017	51,122

<u>TOLL RATE STRUCTURE</u>		
	<u>E-PASS</u>	<u>CASH</u>
2 Axles	\$ 0.76	\$ 1.00
3 Axles	\$ 1.01	\$ 1.25
4 Axles	\$ 1.26	\$ 1.50
5 Axles or more	\$ 1.26	\$ 1.50

LANES OF EQUIPMENT

- 6 Manned Booths with E-PASS (MA)
- 2 Booths with ACM's and E-PASS
- 4 Express E-PASS (E-PASS only)
- * Changeable Message Sign

LEGEND

- ① Lane Number
- Ⓐ Island Designation



**SR 528 (BEACHLINE EXPRESSWAY)
Dallas Mainline Toll Facility**

SECTION III



Approx. Scale: 1" = 200'
January 2017

Dallas Mainline Toll Facility SR 528 - Beachline Expressway

Fiscal Year 2017 Monthly Mainline & Ramp Toll Transactions and Revenue Summary

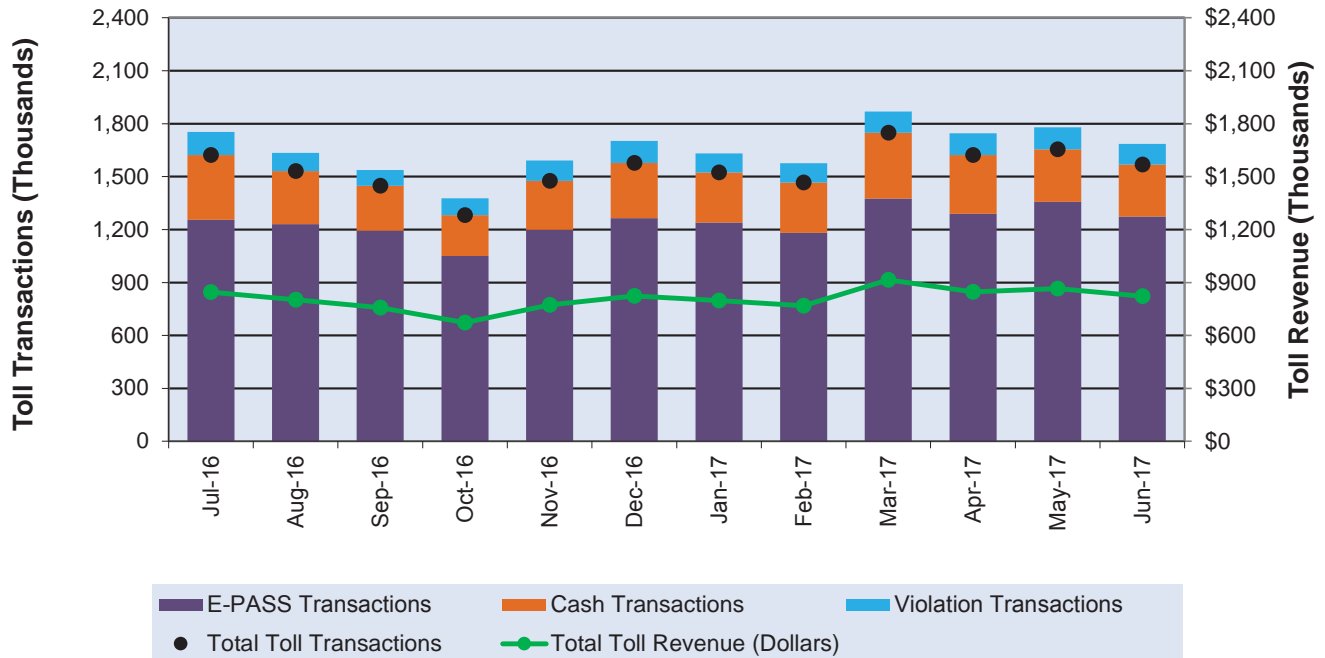

Month	FY 17 MONTHLY MAINLINE & RAMP TOLL TRANSACTIONS					Total Toll Revenue
	E-PASS	Cash	Total Revenue	Violations	Total	
July-16	1,254,814	367,064	1,621,878	130,635	1,752,513	\$845,801
August-16	1,230,821	299,681	1,530,502	103,644	1,634,146	\$801,781
September-16	1,193,512	254,331	1,447,843	89,628	1,537,471	\$757,827
October-16	1,050,133	231,574	1,281,707	95,773	1,377,480	\$672,785
November-16	1,198,755	276,752	1,475,507	116,337	1,591,844	\$772,416
December-16	1,265,320	312,432	1,577,752	125,195	1,702,947	\$823,718
January-17	1,239,948	283,975	1,523,923	106,967	1,630,890	\$797,946
February-17	1,181,769	285,372	1,467,141	108,674	1,575,815	\$767,987
March-17	1,375,569	372,404	1,747,973	121,544	1,869,517	\$914,075
April-17	1,288,575	334,327	1,622,902	122,024	1,744,926	\$846,940
May-17	1,357,245	296,700	1,653,945	126,036	1,779,981	\$865,815
June-17	1,274,306	294,566	1,568,872	117,151	1,686,023	\$822,089
Yearly Totals	14,910,767	3,609,178	18,519,945	1,363,608	19,883,553	\$9,689,180

Note: Data includes ramp toll plazas that report to the Dallas Mainline Toll Plaza.

1. Cash transactions were calculated as the difference between total revenue traffic and E-PASS traffic
2. All plazas had tolls suspended in FY 17 due to Hurricane Matthew from 10/5/16 until early on 10/10/16



Dallas Mainline Toll Facility
SR 528 - Beachline Expressway
Typical Daily Expressway Traffic Volumes - April 2017

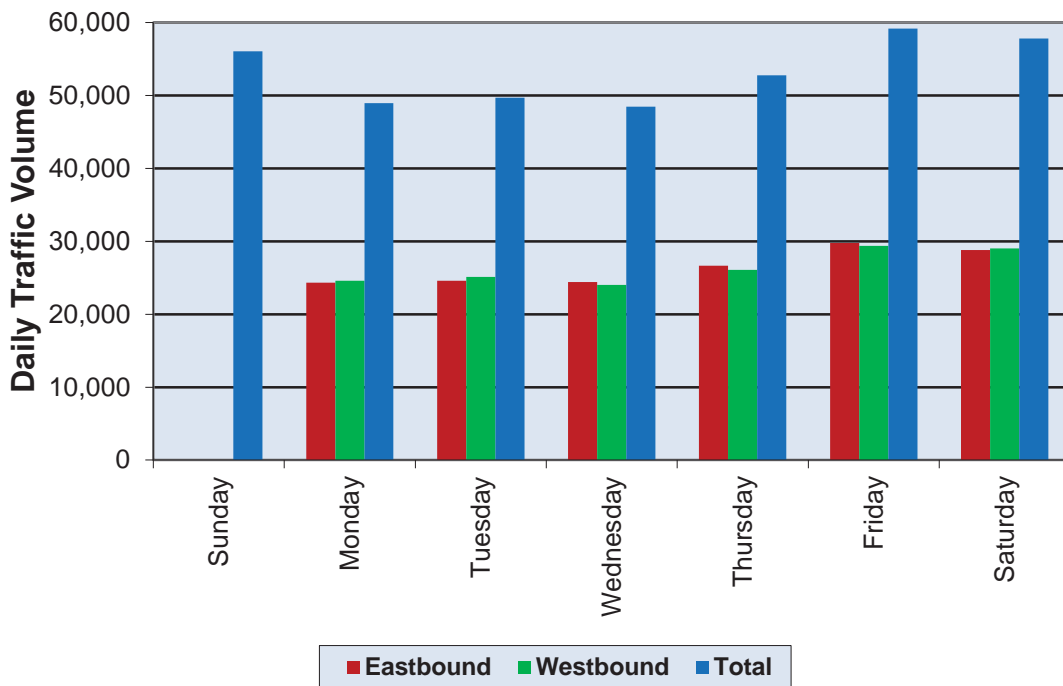

Day	Expressway Traffic Volumes		
	Eastbound	Westbound	Total
Sunday	27,040	27,360	54,400
Monday	24,330	24,610	48,940
Tuesday	24,610	25,110	49,720
Wednesday	24,420	24,040	48,460
Thursday	26,680	26,100	52,780
Friday	29,790	29,370	59,160
Saturday	28,790	29,020	57,810

Dallas Mainline Toll Facility
SR 528 - Beachline Expressway
Typical Average Five Day Hourly Traffic - April 2017

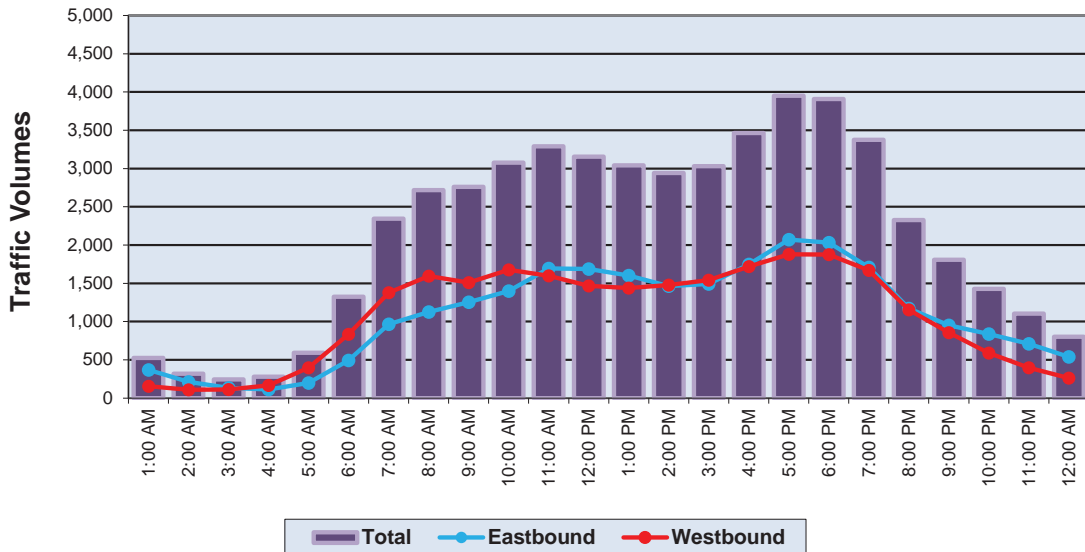

Hour Ending	Average Weekday Volumes		
	Eastbound	Westbound	Total
1:00 AM	368	156	524
2:00 AM	211	109	320
3:00 AM	133	111	244
4:00 AM	113	167	280
5:00 AM	197	396	593
6:00 AM	492	834	1,326
7:00 AM	967	1,376	2,343
8:00 AM	1,125	1,593	2,718
9:00 AM	1,252	1,509	2,761
10:00 AM	1,398	1,678	3,076
11:00 AM	1,693	1,597	3,290
12:00 PM	1,688	1,466	3,154

Hour Ending	Average Weekday Volumes		
	Eastbound	Westbound	Total
1:00 PM	1,603	1,439	3,042
2:00 PM	1,462	1,479	2,941
3:00 PM	1,490	1,541	3,031
4:00 PM	1,746	1,719	3,465
5:00 PM	2,070	1,880	3,950
6:00 PM	2,033	1,875	3,908
7:00 PM	1,708	1,668	3,376
8:00 PM	1,173	1,153	2,326
9:00 PM	952	856	1,808
10:00 PM	838	589	1,427
11:00 PM	710	395	1,105
12:00 AM	540	263	803

Total Eastbound	25,962
Total Westbound	25,849
Total Weekday	51,811

Dallas Mainline Toll Facility
SR 528 - Beachline Expressway
 Typical Average Seven Day Hourly Traffic - April 2017

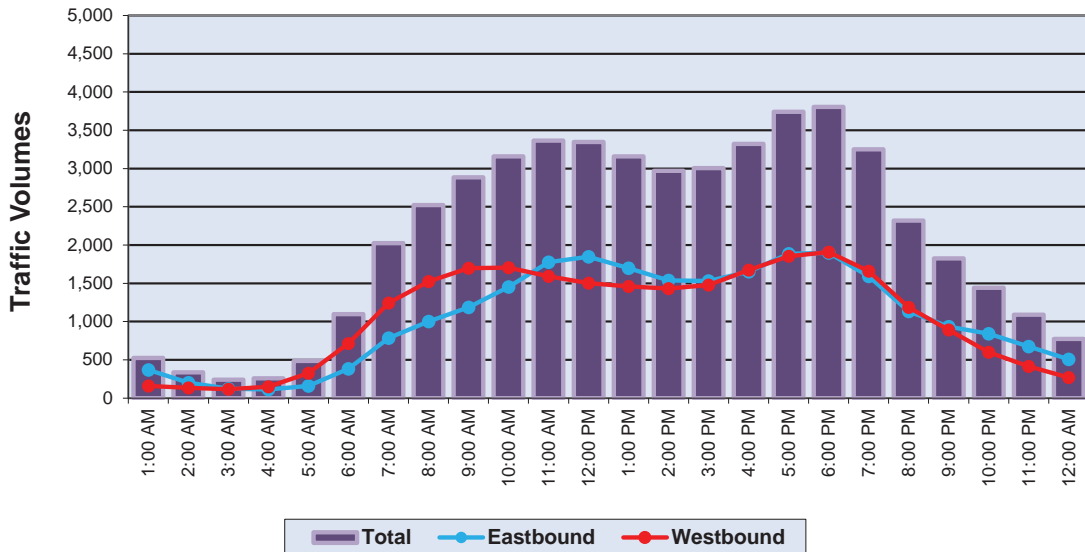

Hour Ending	Average Weekday Volumes		
	Eastbound	Westbound	Total
1:00 AM	368	157	526
2:00 AM	203	135	338
3:00 AM	122	117	239
4:00 AM	113	147	260
5:00 AM	159	325	484
6:00 AM	382	713	1,095
7:00 AM	783	1,243	2,026
8:00 AM	1,001	1,522	2,523
9:00 AM	1,187	1,698	2,885
10:00 AM	1,453	1,704	3,157
11:00 AM	1,777	1,590	3,366
12:00 PM	1,847	1,501	3,348

Hour Ending	Average Weekday Volumes		
	Eastbound	Westbound	Total
1:00 PM	1,699	1,458	3,157
2:00 PM	1,538	1,432	2,970
3:00 PM	1,531	1,476	3,007
4:00 PM	1,651	1,673	3,323
5:00 PM	1,886	1,855	3,741
6:00 PM	1,898	1,907	3,805
7:00 PM	1,591	1,660	3,251
8:00 PM	1,132	1,187	2,319
9:00 PM	933	891	1,824
10:00 PM	840	600	1,440
11:00 PM	674	416	1,089
12:00 AM	507	267	775

Total Eastbound	25,275
Total Westbound	25,674
Total Weekday	50,948

Dallas Mainline Toll Facility

Toll Facility Peak Hour Characteristic Summary Typical Average Weekday (Monday through Friday) - April 2017

Average Weekday Traffic Summary (unadjusted)

Average Weekday Total Traffic	51,811
Eastbound Directional Traffic	25,962
Westbound Directional Traffic	25,849

Morning Peak Hour Summary (7:00 a.m. to 8:00 a.m.)

Eastbound Directional Traffic	1,252
Westbound Directional Traffic	1,509
Total AM Peak Hour Traffic	2,761

AM Peak Hour Factor ("K") = Total Peak Hour Traffic / Average Weekday Total Traffic

AM Peak Hour Factor ("K_{am}") **5.33%**

AM Peak Hour Directional Factor ("D") = Peak Directional Traffic / Total Peak Hour Traffic

AM Peak Hour Directional Factor ("D_{am}") **54.65%**

Evening Peak Hour Summary (5:00 p.m. to 6:00 p.m.)

Eastbound Directional Traffic	2,033
Westbound Directional Traffic	1,875
Total PM Peak Hour Traffic	3,908

PM Peak Hour Factor ("K") = Total Peak Hour Traffic / Average Weekday Total Traffic

PM Peak Hour Factor ("K_{pm}") **7.54%**

PM Peak Hour Directional Factor ("D") = Peak Directional Traffic / Total Peak Hour Traffic

PM Peak Hour Directional Factor ("D_{pm}") **52.02%**

Dallas Mainline Toll Facility

Toll Transaction Summary

Typical Average Weekday (Monday through Friday) - April 2017

Average Weekday Summary

Direction of Travel	E-PASS (AVI)		ACM (Coin)		Manual (Cash)		Total	
	Volume	% Usage	Volume	% Usage	Volume	% Usage	Traffic	% Usage
Eastbound	20,939	81%	921	4%	4,102	16%	25,962	100%
Westbound	20,671	80%	996	4%	4,182	16%	25,849	100%

Morning Peak Hour Summary (7:00 a.m. to 8:00 a.m.)

Direction of Travel	E-PASS (AVI)		ACM (Coin)		Manual (Cash)		Total	
	Volume	% Usage	Volume	% Usage	Volume	% Usage	Traffic	% Usage
Eastbound	1,083	87%	26	2%	143	11%	1,252	100%
Westbound	1,257	83%	37	2%	215	14%	1,509	100%

Evening Peak Hour Summary (5:00 p.m. to 6:00 p.m.)

Direction of Travel	E-PASS (AVI)		ACM (Coin)		Manual (Cash)		Total	
	Volume	% Usage	Volume	% Usage	Volume	% Usage	Traffic	% Usage
Eastbound	1,729	85%	60	3%	244	12%	2,033	100%
Westbound	1,457	78%	87	5%	331	18%	1,875	100%

Dallas Mainline Toll Facility
SR 528 - Beachline Expressway
Historical & Existing Total Revenue Transactions Statistics

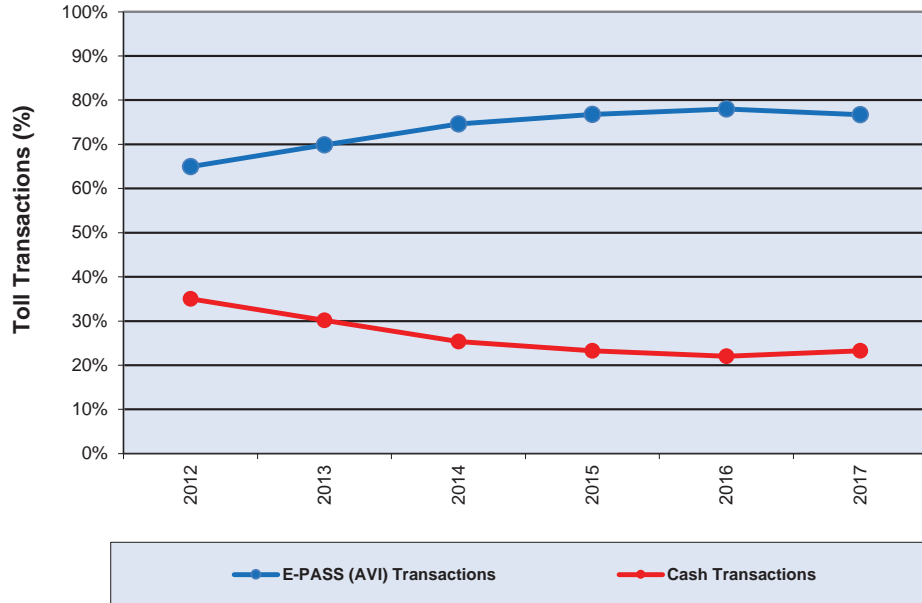

Year	Yearly Revenue Transaction		% Violations ⁽²⁾ (Percent of Total Transactions)
	% E-PASS (AVI) Transactions	% Cash Transactions	
2000	Not Open to Traffic		
2001	Not Open to Traffic		
2002	Not Open to Traffic		
2003	Not Open to Traffic		
2004	Not Open to Traffic		
2005	Not Open to Traffic		
2006	Not Open to Traffic		
2007	Not Open to Traffic		
2008	Not Open to Traffic		
2009	Not Open to Traffic		
2010	Not Open to Traffic		
2011	Not Open to Traffic		
2012	64.9%	35.1%	3.3%
2013	69.8%	30.2%	3.6%
2014	74.6%	25.4%	4.2%
2015	76.7%	23.3%	4.9%
2016	78.0%	22.0%	5.7%
2017	76.7%	23.3%	11.3%

1. All plazas had tolls suspended from 9/5/17 until 9/21/17 due to Hurricane Irma
2. Calculated as percent of Total Transactions, which is equal to Revenue Transactions plus Violations

John Young Mainline Toll Facility (Central Florida GreeneWay)



2017 Traffic Data and Statistics Manual
CENTRAL FLORIDA EXPRESSWAY AUTHORITY

OSCEOLA



Admin.
Blg.

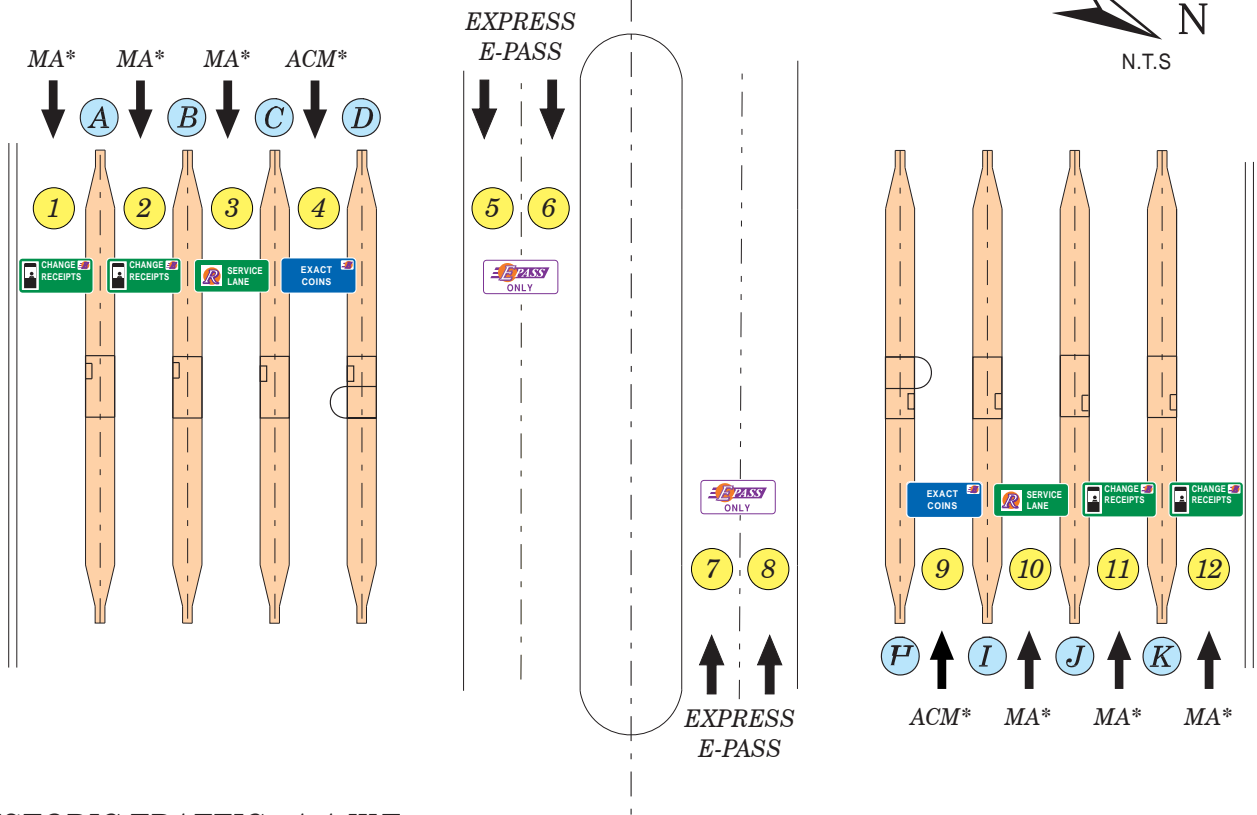

HISTORIC TRAFFIC - A.A.W.T.

1993	7,370	2015	51,500
1994	11,370	2016	62,150
1995	13,070	2017	76,880
1996	17,520		
1997	20,550		
1998	22,660		
1999	25,630		
2000	28,660		
2001	29,160		
2002	32,020		
2003	33,240		
2004	40,000		
2005	40,500		
2006	42,700		
2007	45,800		
2008	43,500		
2009	38,200	(Toll Increase April 2009)	
2010	39,630		
2011	41,400		
2012	41,300	(Toll Increase July 2012)	
2013	41,840		
2014	44,780		

TOLL RATE STRUCTURE **

	<u>E-PASS</u>	<u>CASH</u>
2 Axles	\$ 1.37	\$ 1.50
3 Axles	\$ 1.91	\$ 2.00
4 Axles	\$ 2.46	\$ 2.50
5 Axles or more	\$ 3.00	\$ 3.00

LANES OF EQUIPMENT

- 6 Manned Booths with E-PASS (MA)
- 2 ACM's with E-PASS
- 4 Express E-PASS
- * Changeable Message Sign

LEGEND

- ① Lane Number
- Ⓐ Island Designation



Approx. Scale: 1" = 200'
January 2017

John Young Mainline Toll Facility SR 417 - Central Florida GreeneWay

Fiscal Year 2017 Monthly Mainline & Ramp Toll Transactions and Revenue Summary

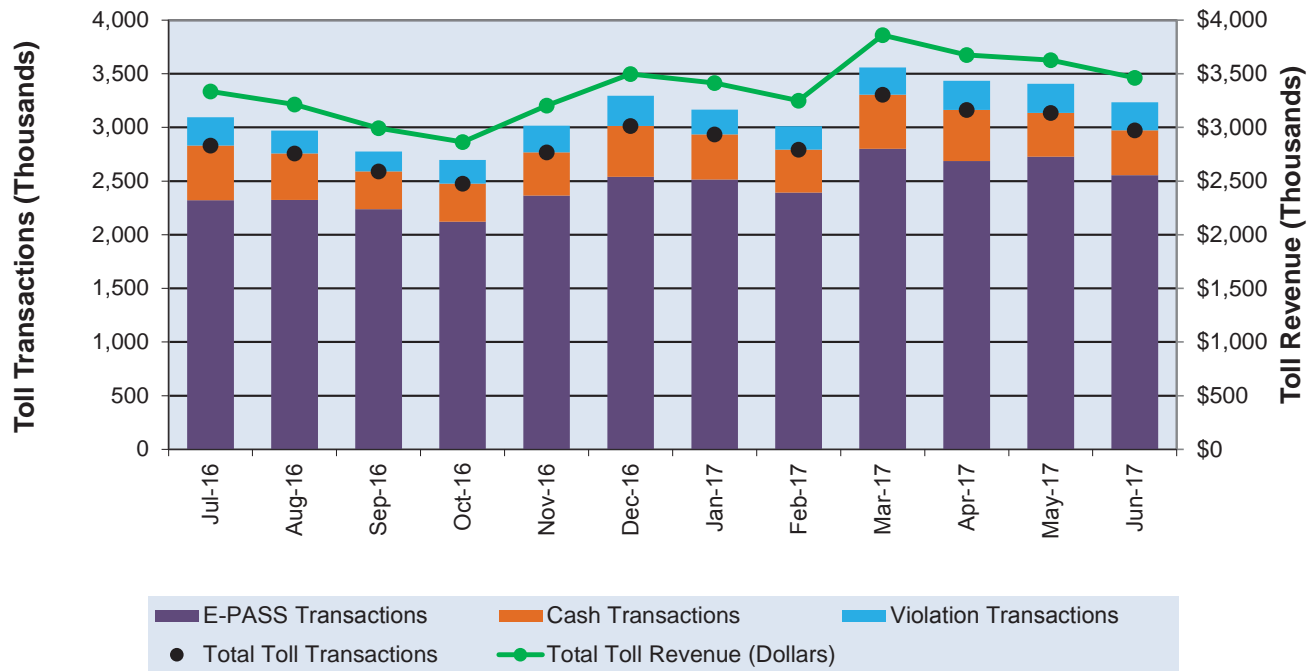

Month	FY 17 MONTHLY MAINLINE & RAMP TOLL TRANSACTIONS					Total Toll Revenue
	E-PASS	Cash	Total Revenue	Violations	Total	
July-16	2,320,214	511,524	2,831,738	263,618	3,095,356	\$3,334,441
August-16	2,324,164	433,382	2,757,546	213,268	2,970,814	\$3,212,778
September-16	2,237,196	351,573	2,588,769	185,817	2,774,586	\$2,992,128
October-16	2,120,121	356,555	2,476,676	218,615	2,695,291	\$2,863,856
November-16	2,363,970	402,558	2,766,528	249,211	3,015,739	\$3,204,340
December-16	2,539,035	473,869	3,012,904	280,681	3,293,585	\$3,496,277
January-17	2,512,751	421,588	2,934,339	230,018	3,164,357	\$3,414,254
February-17	2,391,700	401,270	2,792,970	218,209	3,011,179	\$3,250,192
March-17	2,799,186	506,327	3,305,513	253,588	3,559,101	\$3,860,524
April-17	2,685,772	477,446	3,163,218	271,565	3,434,783	\$3,675,849
May-17	2,727,952	408,174	3,136,126	269,028	3,405,154	\$3,626,416
June-17	2,554,333	417,960	2,972,293	261,890	3,234,183	\$3,461,212
Yearly Totals	29,576,394	5,162,226	34,738,620	2,915,508	37,654,128	\$40,392,267

Note: Data includes ramp toll plazas that report to the John Young Mainline Toll Plaza.

1. Cash transactions were calculated as the difference between total revenue traffic and E-PASS traffic
2. All plazas had tolls suspended in FY 17 due to Hurricane Matthew from 10/5/16 until early on 10/10/16



John Young Mainline Toll Facility
SR 417 - Central Florida GreeneWay
Typical Daily Expressway Traffic Volumes - April 2017

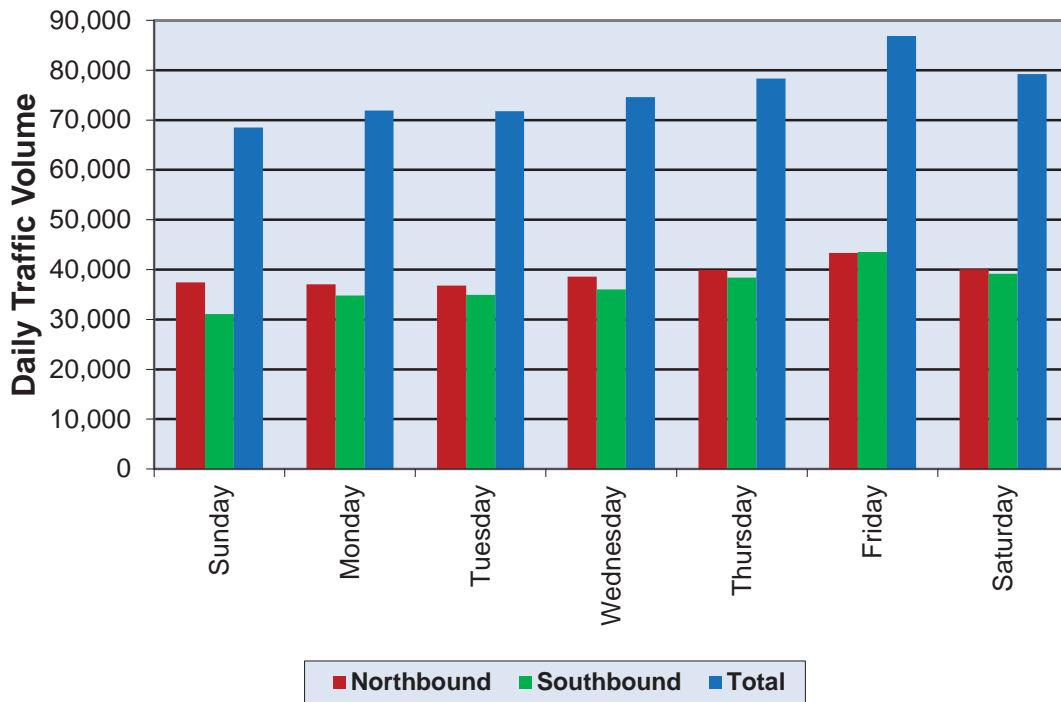

Day	Expressway Traffic Volumes		
	Northbound	Southbound	Total
Sunday	37,430	31,080	68,510
Monday	37,080	34,820	71,900
Tuesday	36,820	34,940	71,760
Wednesday	38,570	36,020	74,590
Thursday	39,950	38,400	78,350
Friday	43,330	43,530	86,860
Saturday	40,040	39,200	79,240

John Young Mainline Toll Facility

SR 417 - Central Florida GreeneWay

Typical Average Five Day Hourly Traffic - April 2017

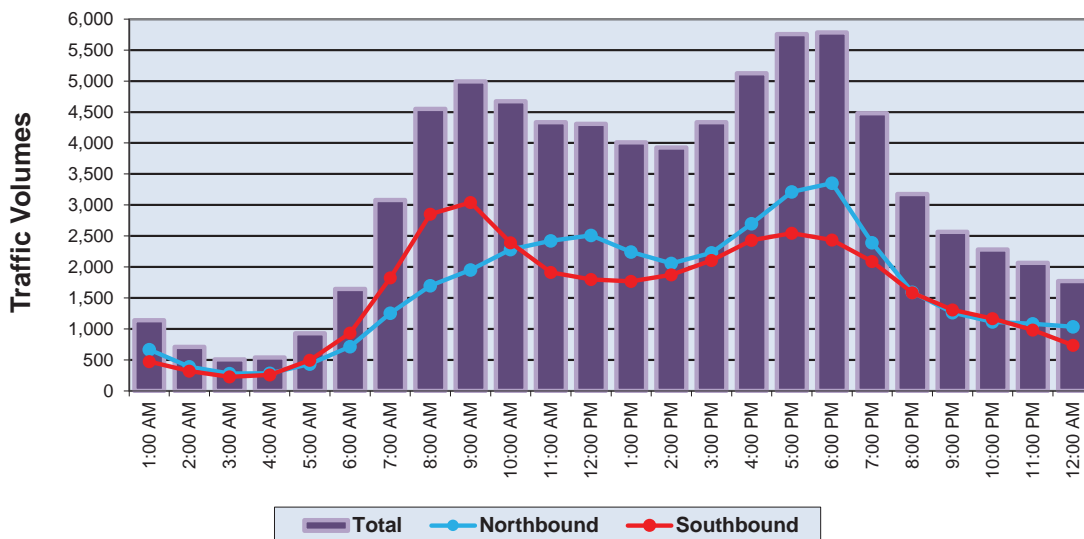

Hour Ending	Average Weekday Volumes			Hour Ending	Average Weekday Volumes		
	Northbound	Southbound	Total		Northbound	Southbound	Total
1:00 AM	666	473	1,139	1:00 PM	2,241	1,769	4,010
2:00 AM	391	320	711	2:00 PM	2,057	1,871	3,928
3:00 AM	280	226	506	3:00 PM	2,230	2,104	4,334
4:00 AM	282	257	539	4:00 PM	2,697	2,429	5,126
5:00 AM	433	494	927	5:00 PM	3,211	2,546	5,757
6:00 AM	712	934	1,646	6:00 PM	3,352	2,433	5,785
7:00 AM	1,255	1,826	3,081	7:00 PM	2,391	2,090	4,481
8:00 AM	1,697	2,852	4,549	8:00 PM	1,592	1,583	3,175
9:00 AM	1,953	3,040	4,993	9:00 PM	1,261	1,307	2,568
10:00 AM	2,282	2,391	4,673	10:00 PM	1,115	1,167	2,282
11:00 AM	2,423	1,911	4,334	11:00 PM	1,081	984	2,065
12:00 PM	2,511	1,797	4,308	12:00 AM	1,036	737	1,773

Total Northbound	39,149
Total Southbound	37,541
Total Weekday	76,690

John Young Mainline Toll Facility
SR 417 - Central Florida GreeneWay
Typical Average Seven Day Hourly Traffic - April 2017

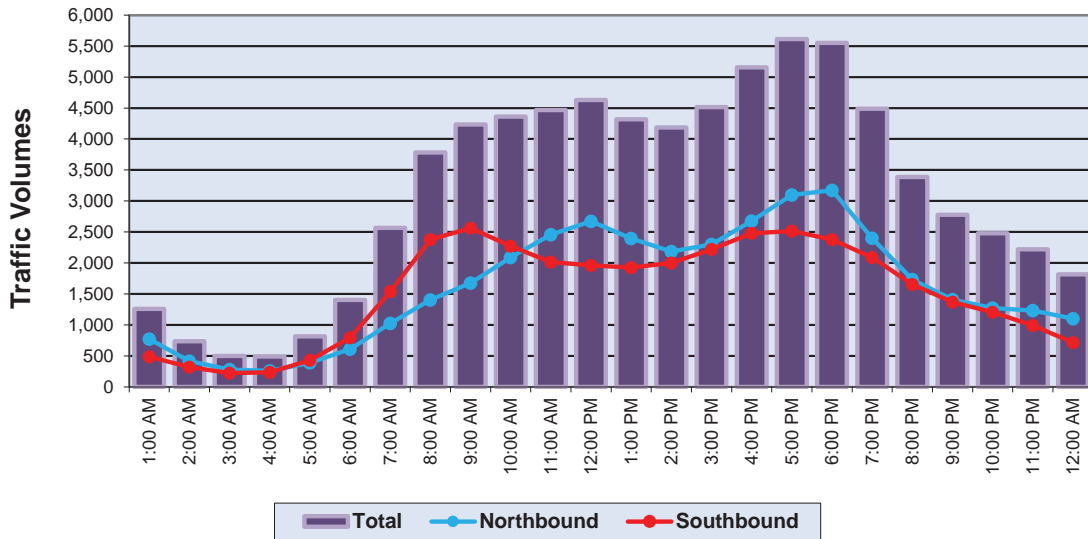

Hour Ending	Average Weekday Volumes			Hour Ending	Average Weekday Volumes		
	Northbound	Southbound	Total		Northbound	Southbound	Total
1:00 AM	771	486	1,256	1:00 PM	2,394	1,924	4,318
2:00 AM	417	318	735	2:00 PM	2,185	1,999	4,185
3:00 AM	278	223	500	3:00 PM	2,297	2,219	4,516
4:00 AM	255	236	492	4:00 PM	2,677	2,480	5,157
5:00 AM	388	429	817	5:00 PM	3,097	2,515	5,613
6:00 AM	610	792	1,402	6:00 PM	3,174	2,378	5,552
7:00 AM	1,026	1,539	2,566	7:00 PM	2,400	2,090	4,490
8:00 AM	1,405	2,377	3,782	8:00 PM	1,734	1,654	3,388
9:00 AM	1,676	2,560	4,236	9:00 PM	1,407	1,369	2,776
10:00 AM	2,086	2,274	4,361	10:00 PM	1,273	1,205	2,477
11:00 AM	2,456	2,012	4,468	11:00 PM	1,230	991	2,221
12:00 PM	2,672	1,960	4,631	12:00 AM	1,101	713	1,814

Total Northbound	39,012
Total Southbound	36,741
Total Weekday	75,753

John Young Mainline Toll Facility
Toll Facility Peak Hour Characteristic Summary
Typical Average Weekday (Monday through Friday) - April 2017

Average Weekday Traffic Summary (unadjusted)

Average Weekday Total Traffic	76,690
Northbound Directional Traffic	39,149
Southbound Directional Traffic	37,541

Morning Peak Hour Summary (7:00 a.m. to 8:00 a.m.)

Northbound Directional Traffic	1,953
Southbound Directional Traffic	3,040
Total AM Peak Hour Traffic	4,993

AM Peak Hour Factor ("K") = Total Peak Hour Traffic / Average Weekday Total Traffic

AM Peak Hour Factor ("K_{am}")	6.51%
---	--------------

AM Peak Hour Directional Factor ("D") = Peak Directional Traffic / Total Peak Hour Traffic

AM Peak Hour Directional Factor ("D_{am}")	60.89%
---	---------------

Evening Peak Hour Summary (5:00 p.m. to 6:00 p.m.)

Northbound Directional Traffic	3,352
Southbound Directional Traffic	2,433
Total PM Peak Hour Traffic	5,785

PM Peak Hour Factor ("K") = Total Peak Hour Traffic / Average Weekday Total Traffic

PM Peak Hour Factor ("K_{pm}")	7.54%
---	--------------

PM Peak Hour Directional Factor ("D") = Peak Directional Traffic / Total Peak Hour Traffic

PM Peak Hour Directional Factor ("D_{pm}")	57.94%
---	---------------

John Young Mainline Toll Facility

Toll Transaction Summary

Typical Average Weekday (Monday through Friday) - April 2017

Average Weekday Summary

Direction of Travel	E-PASS (AVI)		ACM (Coin)		Manual (Cash)		Total	
	Volume	% Usage	Volume	% Usage	Volume	% Usage	Traffic	% Usage
Northbound	32,707	84%	1,200	3%	5,242	13%	39,149	100%
Southbound	32,053	85%	687	2%	4,801	13%	37,541	100%

Morning Peak Hour Summary (7:00 a.m. to 8:00 a.m.)

Direction of Travel	E-PASS (AVI)		ACM (Coin)		Manual (Cash)		Total	
	Volume	% Usage	Volume	% Usage	Volume	% Usage	Traffic	% Usage
Northbound	1,672	86%	38	2%	243	12%	1,953	100%
Southbound	2,787	92%	29	1%	224	7%	3,040	100%

Evening Peak Hour Summary (5:00 p.m. to 6:00 p.m.)

Direction of Travel	E-PASS (AVI)		ACM (Coin)		Manual (Cash)		Total	
	Volume	% Usage	Volume	% Usage	Volume	% Usage	Traffic	% Usage
Northbound	2,602	78%	275	8%	475	14%	3,352	100%
Southbound	1,984	82%	57	2%	392	16%	2,433	100%

John Young Mainline Toll Facility
SR 417 - Central Florida GreenWay
Historical & Existing Total Revenue Transactions Statistics

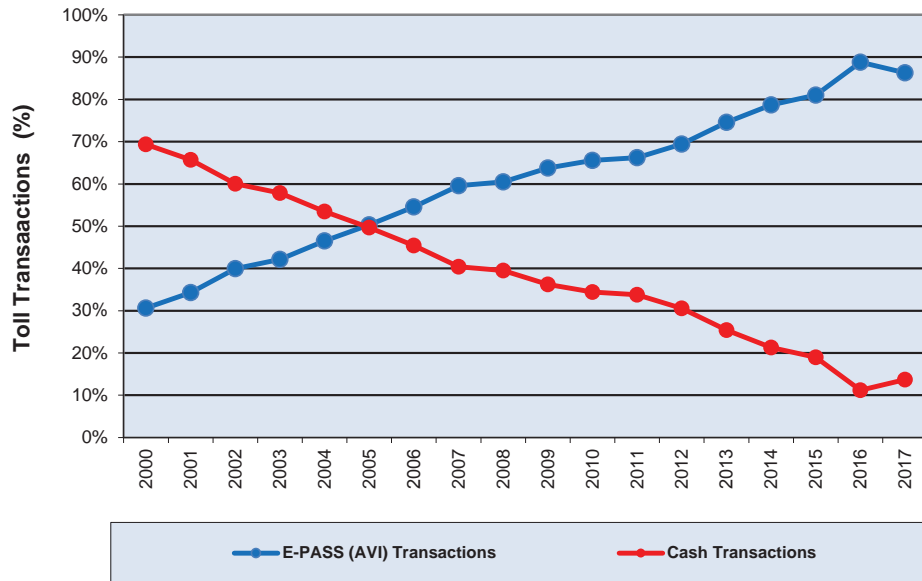

Year	Yearly Revenue Transaction		% Violations ⁽²⁾ (Percent of Total Transactions)
	% E-PASS (AVI) Transactions	% Cash Transactions	
2000	30.6%	69.4%	1.8%
2001	34.3%	65.7%	1.7%
2002	40.0%	60.0%	1.6%
2003	42.1%	57.9%	1.5%
2004	46.5%	53.5%	1.7%
2005	50.3%	49.7%	2.0%
2006	54.6%	45.4%	2.5%
2007	59.6%	40.4%	2.6%
2008	60.5%	39.5%	2.5%
2009	63.8%	36.2%	2.9%
2010	65.6%	34.4%	2.8%
2011	66.2%	33.8%	2.5%
2012	69.4%	30.6%	3.1%
2013	74.6%	25.4%	3.3%
2014	78.7%	21.3%	4.3%
2015	81.0%	19.0%	5.2%
2016	88.8%	11.2%	6.5%
2017	86.3%	13.7%	8.8%

1. All plazas had tolls suspended from 9/5/17 until 9/21/17 due to Hurricane Irma

2. Calculated as percent of Total Transactions, which is equal to Revenue Transactions plus Violations

Boggy Creek Mainline Toll Facility (Central Florida GreeneWay)



2017 Traffic Data and Statistics Manual
CENTRAL FLORIDA EXPRESSWAY AUTHORITY

OSCEOLA

MA* MA* MA* MA* ACM*

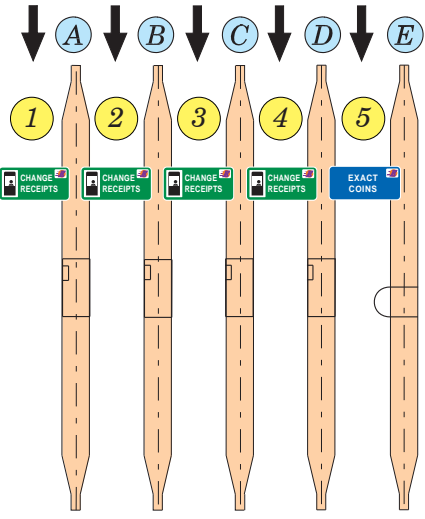

EXPRESS E-PASS

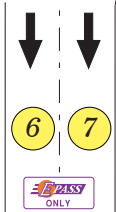

E-PASS ONLY

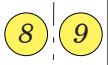

EXPRESS E-PASS

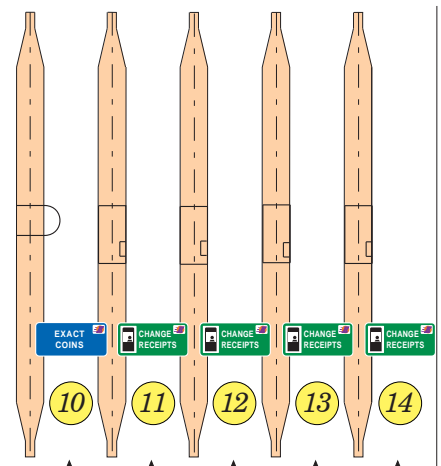

ACM* MA* MA* MA* MA*

HISTORIC TRAFFIC - A.A.W.T.

1993	6,0200	2015	54,580
1994	10,750	2016	66,700
1995	11,970	2017	78,830
1996	15,780		
1997	17,760		
1998	20,400		
1999	22,440		
2000	24,380		
2001	25,180		
2002	28,120		
2003	30,190		
2004	36,920		
2005	37,900		
2006	42,400		
2007	44,800		
2008	44,400		
2009	35,900	(Toll Increase April 2009)	
2010	36,520		
2011	38,300		
2012	38,350	(Toll Increase July 2012)	
2013	40,300		
2014	44,880		

TOLL RATE STRUCTURE **

	E-PASS	CASH
2 Axles	\$ 1.37	\$ 1.50
3 Axles	\$ 1.91	\$ 2.00
4 Axles	\$ 2.46	\$ 2.50
5 Axles or more	\$ 3.00	\$ 3.00

LANES OF EQUIPMENT

- 8 Manned Booths with E-PASS (MA)
- 2 ACM with E-PASS
- 4 Express E-PASS
- * Changeable Message Sign

LEGEND

- ① Lane Number
- Ⓐ Island Designation



**SR 417 (CENTRAL FLORIDA GREENEWAY)
Boggy Creek Mainline Toll Facility**



Approx. Scale: 1" = 200'
January 2017

Boggy Creek Mainline Toll Facility SR 417 - Central Florida GreeneWay

Fiscal Year 2017 Monthly Mainline & Ramp Toll Transactions and Revenue Summary

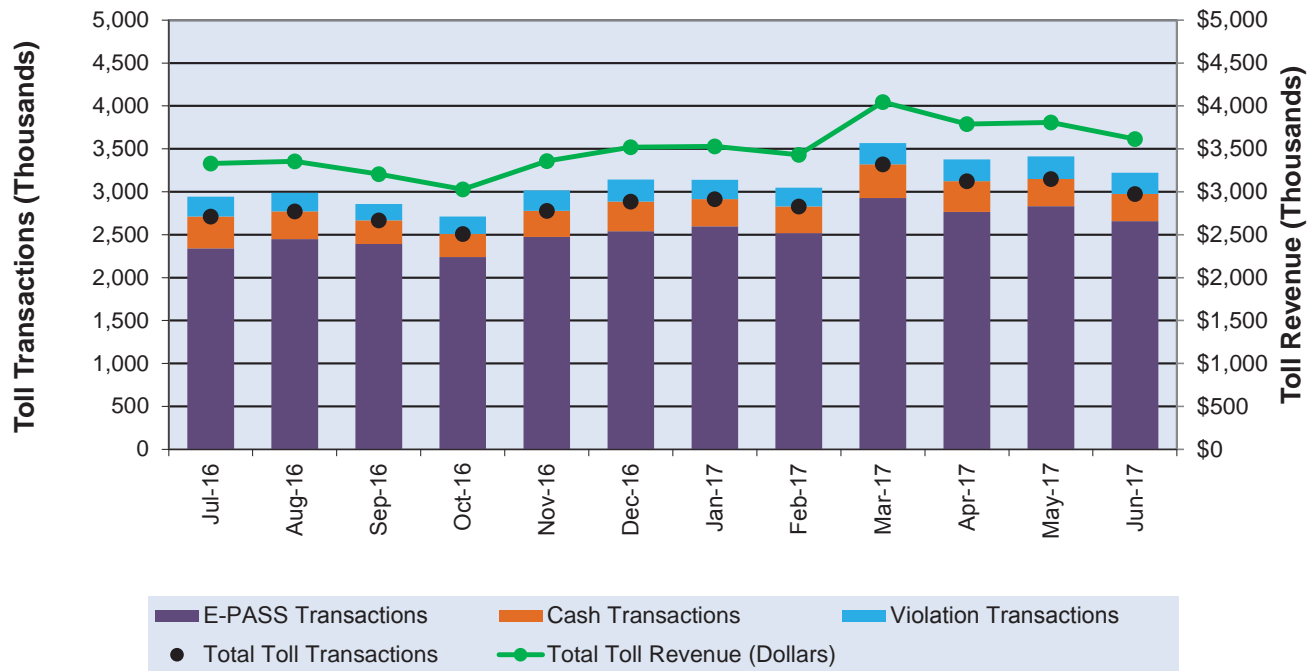

Month	FY 17 MONTHLY MAINLINE & RAMP TOLL TRANSACTIONS					Total Toll Revenue
	E-PASS	Cash	Total Revenue	Violations	Total	
July-16	2,339,426	373,065	2,712,491	229,509	2,942,000	\$3,327,869
August-16	2,449,290	321,314	2,770,604	216,215	2,986,819	\$3,355,284
September-16	2,392,365	274,197	2,666,562	190,556	2,857,118	\$3,207,158
October-16	2,240,162	269,736	2,509,898	200,837	2,710,735	\$3,029,144
November-16	2,473,332	304,748	2,778,080	237,222	3,015,302	\$3,358,240
December-16	2,539,643	345,916	2,885,559	257,624	3,143,183	\$3,519,528
January-17	2,597,585	316,838	2,914,423	225,817	3,140,240	\$3,528,338
February-17	2,519,523	309,818	2,829,341	217,852	3,047,193	\$3,430,648
March-17	2,927,509	391,720	3,319,229	247,838	3,567,067	\$4,045,740
April-17	2,764,745	359,565	3,124,310	252,800	3,377,110	\$3,788,502
May-17	2,832,180	317,580	3,149,760	262,234	3,411,994	\$3,807,099
June-17	2,656,677	317,648	2,974,325	248,254	3,222,579	\$3,614,437
Yearly Totals	30,732,437	3,902,145	34,634,582	2,786,758	37,421,340	\$42,011,987

Note: Data includes ramp toll plazas that report to the Boggy Creek Mainline Toll Plaza.

1. Cash transactions were calculated as the difference between total revenue traffic and E-PASS traffic
2. All plazas had tolls suspended in FY 17 due to Hurricane Matthew from 10/5/16 until early on 10/10/16

Boggy Creek Mainline Toll Facility
SR 417 - Central Florida GreenWay
Typical Daily Expressway Traffic Volumes - April 2017

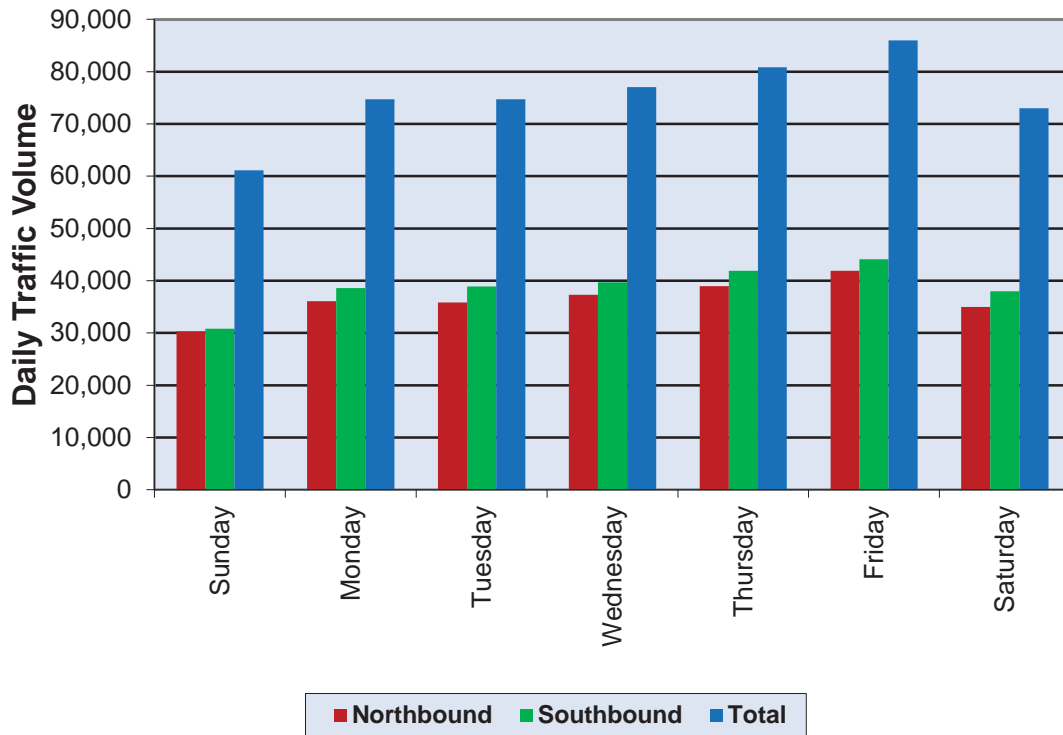

Day	Expressway Traffic Volumes		
	Northbound	Southbound	Total
Sunday	30,330	30,790	61,120
Monday	36,080	38,610	74,690
Tuesday	35,820	38,900	74,720
Wednesday	37,330	39,710	77,040
Thursday	38,950	41,920	80,870
Friday	41,870	44,110	85,980
Saturday	35,000	37,980	72,980

Boggy Creek Mainline Toll Facility

SR 417 - Central Florida GreeneWay

Typical Average Five Day Hourly Traffic - April 2017

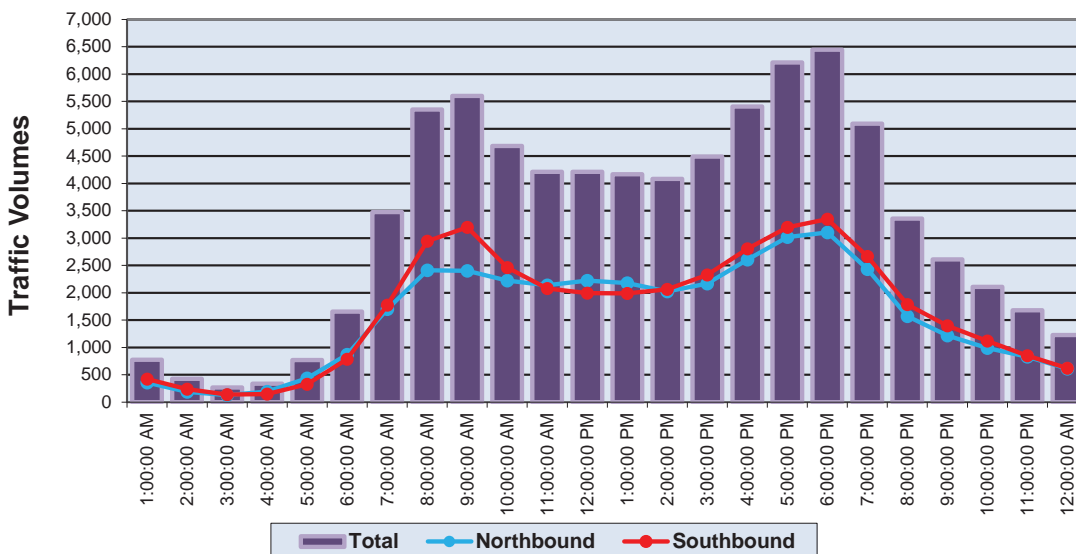

Hour Ending	Average Weekday Volumes		
	Northbound	Southbound	Total
1:00 AM	357	419	776
2:00 AM	189	237	426
3:00 AM	130	137	267
4:00 AM	191	147	338
5:00 AM	438	329	767
6:00 AM	867	786	1,653
7:00 AM	1,700	1,777	3,477
8:00 AM	2,411	2,943	5,354
9:00 AM	2,404	3,199	5,603
10:00 AM	2,221	2,463	4,684
11:00 AM	2,136	2,076	4,212
12:00 PM	2,222	1,992	4,214

Hour Ending	Average Weekday Volumes		
	Northbound	Southbound	Total
1:00 PM	2,179	1,989	4,168
2:00 PM	2,022	2,062	4,084
3:00 PM	2,166	2,325	4,491
4:00 PM	2,605	2,804	5,409
5:00 PM	3,017	3,196	6,213
6:00 PM	3,102	3,345	6,447
7:00 PM	2,432	2,663	5,095
8:00 PM	1,570	1,785	3,355
9:00 PM	1,216	1,395	2,611
10:00 PM	990	1,116	2,106
11:00 PM	829	849	1,678
12:00 AM	611	618	1,229

Total Northbound	38,005
Total Southbound	40,652
Total Weekday	78,657

Boggy Creek Mainline Toll Facility
SR 417 - Central Florida GreenWay
Typical Average Seven Day Hourly Traffic - April 2017

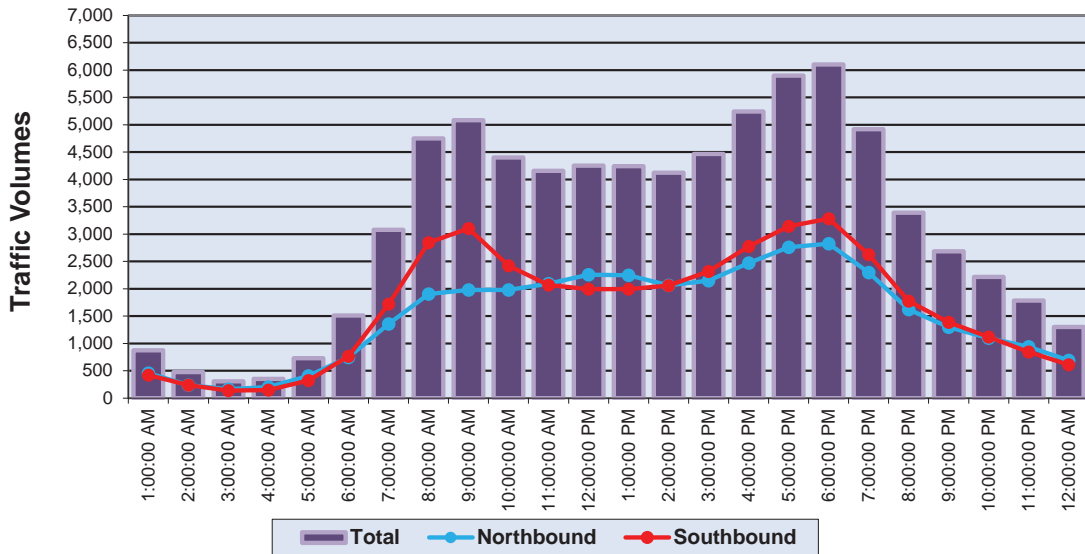

Hour Ending	Average Weekday Volumes		
	Northbound	Southbound	Total
1:00 AM	455	420	875
2:00 AM	235	239	474
3:00 AM	165	140	305
4:00 AM	201	149	349
5:00 AM	407	324	731
6:00 AM	744	764	1,509
7:00 AM	1,357	1,722	3,078
8:00 AM	1,906	2,844	4,750
9:00 AM	1,978	3,104	5,081
10:00 AM	1,980	2,423	4,403
11:00 AM	2,093	2,066	4,159
12:00 PM	2,257	1,996	4,253

Hour Ending	Average Weekday Volumes		
	Northbound	Southbound	Total
1:00 PM	2,249	1,992	4,241
2:00 PM	2,065	2,060	4,125
3:00 PM	2,149	2,317	4,466
4:00 PM	2,469	2,772	5,241
5:00 PM	2,761	3,141	5,902
6:00 PM	2,823	3,281	6,104
7:00 PM	2,295	2,626	4,920
8:00 PM	1,618	1,775	3,393
9:00 PM	1,298	1,386	2,684
10:00 PM	1,098	1,117	2,215
11:00 PM	937	845	1,783
12:00 AM	689	613	1,301

Total Northbound	36,228
Total Southbound	40,115
Total Weekday	76,343

Boggy Creek Mainline Toll Facility

Toll Transaction Summary

Typical Average Weekday (Monday through Friday) - April 2017

Average Weekday Summary

Direction of Travel	E-PASS (AVI)		ACM (Coin)		Manual (Cash)		Total	
	Volume	% Usage	Volume	% Usage	Volume	% Usage	Traffic	% Usage
Northbound	33,215	87%	715	2%	4,075	11%	38,005	100%
Southbound	35,428	87%	793	2%	4,431	11%	40,652	100%

Morning Peak Hour Summary (7:00 a.m. to 8:00 a.m.)

Direction of Travel	E-PASS (AVI)		ACM (Coin)		Manual (Cash)		Total	
	Volume	% Usage	Volume	% Usage	Volume	% Usage	Traffic	% Usage
Northbound	2,127	88%	46	2%	231	10%	2,404	100%
Southbound	3,003	94%	26	1%	170	5%	3,199	100%

Evening Peak Hour Summary (5:00 p.m. to 6:00 p.m.)

Direction of Travel	E-PASS (AVI)		ACM (Coin)		Manual (Cash)		Total	
	Volume	% Usage	Volume	% Usage	Volume	% Usage	Traffic	% Usage
Northbound	2,793	90%	50	2%	259	8%	3,102	100%
Southbound	2,822	84%	104	3%	419	13%	3,345	100%

Boggy Creek Mainline Toll Facility
SR 417 - Central Florida GreeneWay
Historical & Existing Total Revenue Transactions Statistics

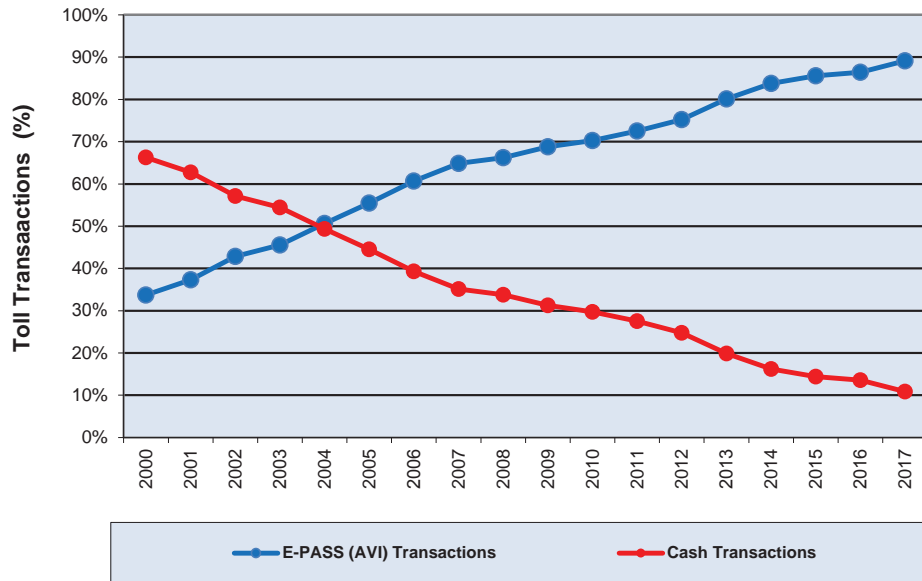

Year	Yearly Revenue Transaction		% Violations ⁽²⁾ (Percent of Total Transactions)
	% E-PASS (AVI) Transactions	% Cash Transactions	
2000	33.7%	66.3%	2.5%
2001	37.3%	62.7%	2.4%
2002	42.8%	57.2%	1.8%
2003	45.5%	54.5%	1.6%
2004	50.6%	49.4%	1.8%
2005	55.4%	44.6%	2.3%
2006	60.7%	39.3%	2.8%
2007	64.9%	35.1%	2.8%
2008	66.2%	33.8%	3.2%
2009	68.8%	31.2%	2.9%
2010	70.3%	29.7%	2.7%
2011	72.5%	27.5%	2.6%
2012	75.2%	24.8%	2.9%
2013	80.1%	19.9%	3.3%
2014	83.8%	16.2%	4.3%
2015	85.6%	14.4%	5.2%
2016	86.4%	13.6%	6.0%
2017	89.1%	10.9%	13.0%

1. All plazas had tolls suspended from 9/5/17 until 9/21/17 due to Hurricane Irma

2. Calculated as percent of Total Transactions, which is equal to Revenue Transactions plus Violations

Curry Ford Mainline Toll Facility (Central Florida GreeneWay)



2017 Traffic Data and Statistics Manual
CENTRAL FLORIDA EXPRESSWAY AUTHORITY

OSCEOLA

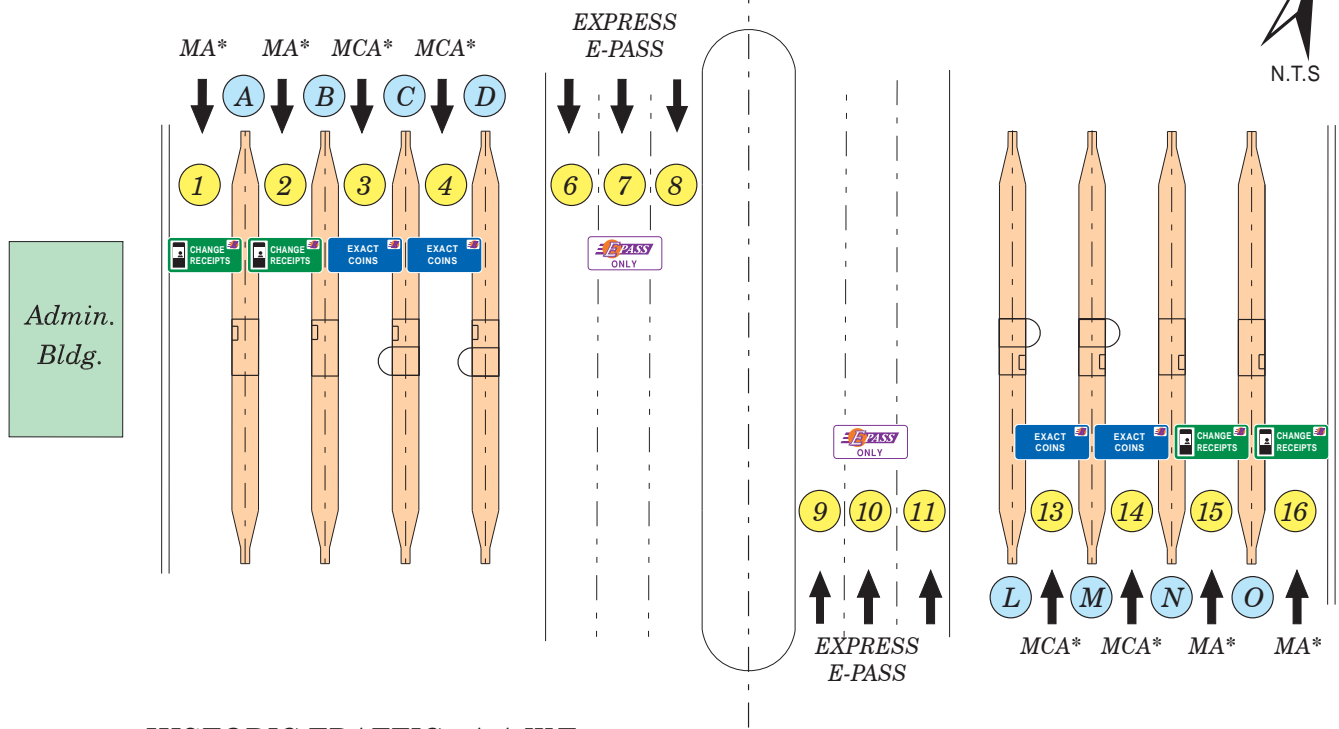

HISTORIC TRAFFIC - A.A.W.T.

1992	9,950 (POST-TOLL)	2015	86,030
1993	13,550	2016	97,280
1994	17,810	2017	105,660
1995	21,810		
1996	26,780		
1997	27,880		
1998	33,530		
1999	39,270		
2000	42,460		
2001	44,290		
2002	50,200		
2003	54,760		
2004	67,010		
2005	69,900		
2006	74,300		
2007	76,100		
2008	68,900		
2009	63,300 (Toll Increase April 2009)		
2010	63,160		
2011	62,530		
2012	64,950 (Toll Increase July 2012)		
2013	66,820		
2014	73,770		

TOLL RATE STRUCTURE		
	<u>E-PASS</u>	<u>CASH</u>
2 Axles	\$.82	\$ 1.00
3 Axles	\$ 1.64	\$ 1.75
4 Axles	\$ 1.91	\$ 2.00
5 Axles or more	\$ 2.46	\$ 2.50

- LANES OF EQUIPMENT**
- 6 Express E-PASS (E-PASS only)
 - 6 Booths with Automatic Coin Machines with E-PASS (MCA)
 - 4 Manned Booths with E-PASS (MA)
- * Changeable Message Sign

- LEGEND**
- ① Lane Number
 - Ⓐ Island Designation



**SR 417 (CENTRAL FLORIDA GREENEWAY)
Curry Ford Mainline Toll Facility**



Approx. Scale: 1" = 200'
January 2016

Curry Ford Mainline Toll Facility SR 417 - Central Florida GreeneWay

Fiscal Year 2017 Monthly Mainline & Ramp Toll Transactions and Revenue Summary

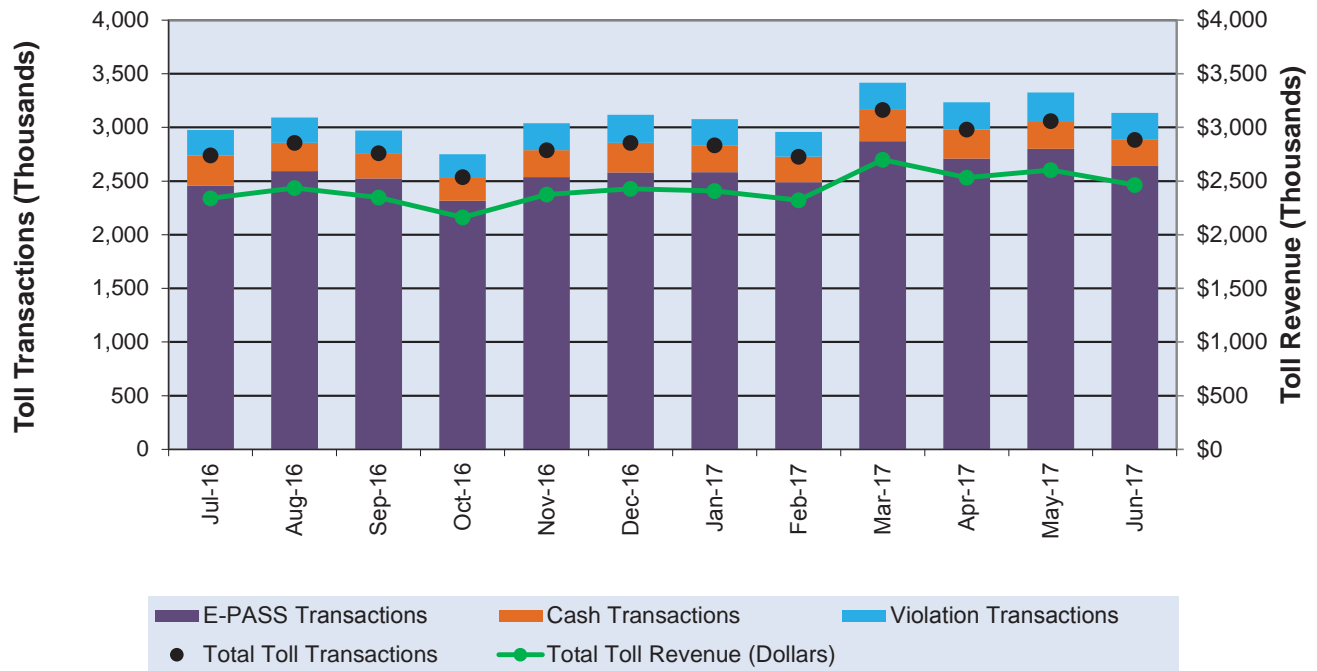

Month	FY 17 MONTHLY MAINLINE & RAMP TOLL TRANSACTIONS					Total Toll Revenue
	E-PASS	Cash	Total Revenue	Violations	Total	
July-16	2,454,634	284,859	2,739,493	235,073	2,974,566	\$2,339,293
August-16	2,592,352	264,436	2,856,788	236,054	3,092,842	\$2,434,612
September-16	2,525,212	234,067	2,759,279	210,492	2,969,771	\$2,345,495
October-16	2,315,664	221,133	2,536,797	213,688	2,750,485	\$2,161,184
November-16	2,537,779	249,967	2,787,746	251,714	3,039,460	\$2,375,077
December-16	2,580,396	275,238	2,855,634	261,139	3,116,773	\$2,428,468
January-17	2,582,286	250,154	2,832,440	245,201	3,077,641	\$2,407,822
February-17	2,488,440	239,331	2,727,771	230,975	2,958,746	\$2,321,158
March-17	2,871,113	291,896	3,163,009	254,410	3,417,419	\$2,699,020
April-17	2,708,028	271,479	2,979,507	253,575	3,233,082	\$2,531,700
May-17	2,801,143	258,524	3,059,667	264,785	3,324,452	\$2,603,870
June-17	2,640,129	244,821	2,884,950	248,890	3,133,840	\$2,463,258
Yearly Totals	31,097,176	3,085,905	34,183,081	2,905,996	37,089,077	\$29,110,957

Note: Data includes ramp toll plazas that report to the Curry Ford Mainline Toll Plaza.

1. Cash transactions were calculated as the difference between total revenue traffic and E-PASS traffic
2. All plazas had tolls suspended in FY 17 due to Hurricane Matthew from 10/5/16 until early on 10/10/16



Curry Ford Mainline Toll Facility SR 417 - Central Florida GreeneWay Typical Daily Traffic Volumes - April 2017

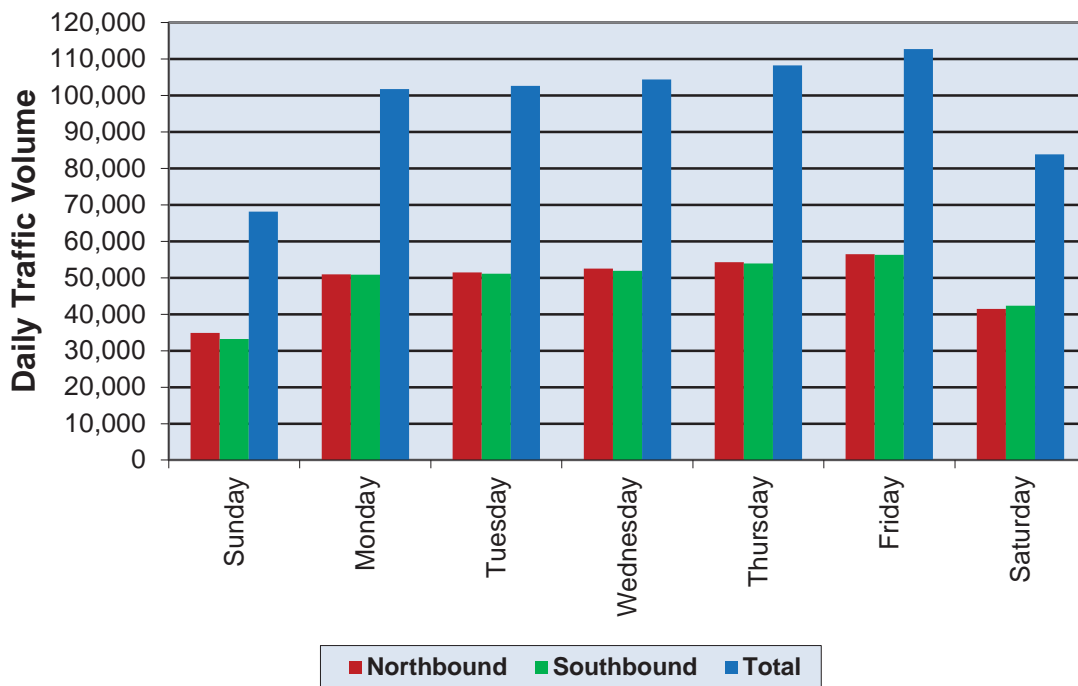

Day	Expressway Traffic Volumes		
	Northbound	Southbound	Total
Sunday	34,870	33,250	68,120
Monday	50,950	50,820	101,770
Tuesday	51,500	51,110	102,610
Wednesday	52,490	51,950	104,440
Thursday	54,280	53,960	108,240
Friday	56,460	56,290	112,750
Saturday	41,500	42,390	83,890

Curry Ford Mainline Toll Facility
SR 417 - Central Florida GreeneWay
Average Five Day Hourly Traffic - April 2017

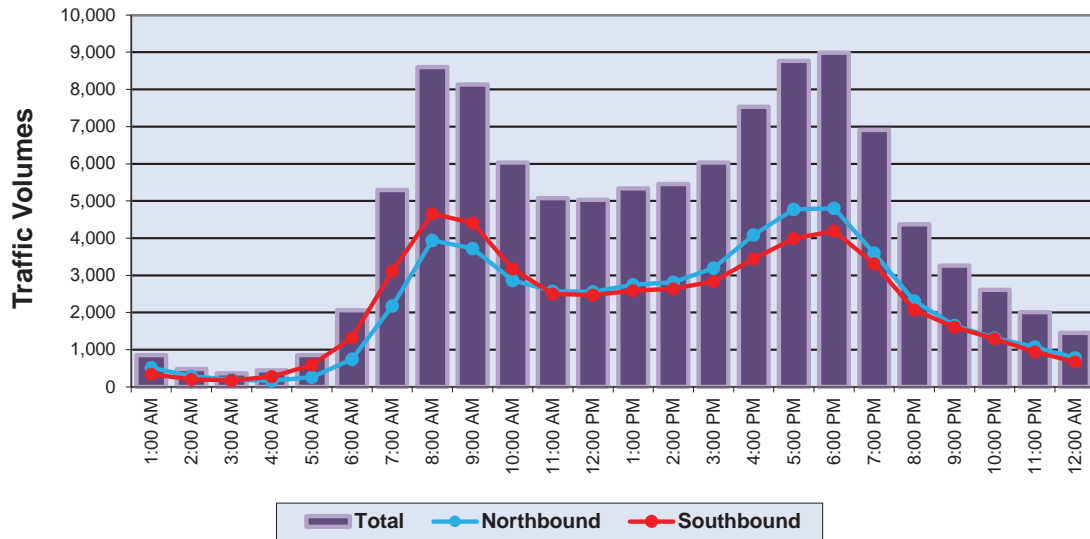

Hour Ending	Average Weekday Volumes		
	Northbound	Southbound	Total
1:00 AM	515	339	854
2:00 AM	281	203	484
3:00 AM	192	173	365
4:00 AM	166	277	443
5:00 AM	261	593	854
6:00 AM	741	1,320	2,061
7:00 AM	2,180	3,111	5,291
8:00 AM	3,942	4,660	8,602
9:00 AM	3,720	4,411	8,131
10:00 AM	2,863	3,173	6,036
11:00 AM	2,570	2,503	5,073
12:00 PM	2,559	2,474	5,033

Hour Ending	Average Weekday Volumes		
	Northbound	Southbound	Total
1:00 PM	2,746	2,589	5,335
2:00 PM	2,816	2,642	5,458
3:00 PM	3,195	2,838	6,033
4:00 PM	4,090	3,440	7,530
5:00 PM	4,774	3,995	8,769
6:00 PM	4,802	4,187	8,989
7:00 PM	3,600	3,311	6,911
8:00 PM	2,307	2,067	4,374
9:00 PM	1,652	1,610	3,262
10:00 PM	1,316	1,296	2,612
11:00 PM	1,070	943	2,013
12:00 AM	784	673	1,457

Total Northbound	53,142
Total Southbound	52,828
Total Weekday	105,970

Curry Ford Mainline Toll Facility
SR 417 - Central Florida GreeneWay
Average Seven Day Hourly Traffic - April 2017

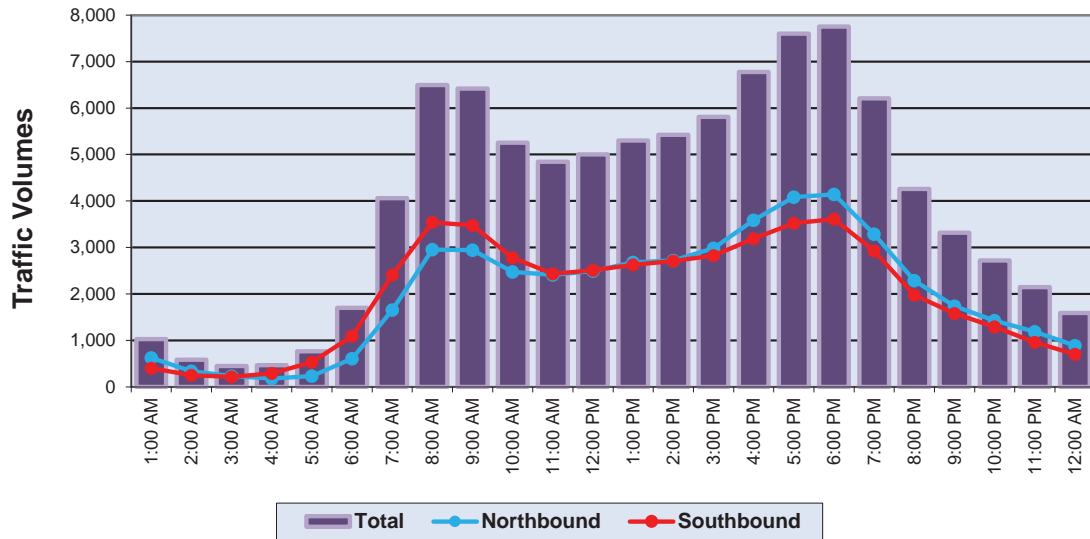

Hour Ending	Average Weekday Volumes			Hour Ending	Average Weekday Volumes		
	Northbound	Southbound	Total		Northbound	Southbound	Total
1:00 AM	627	403	1,030	1:00 PM	2,677	2,623	5,301
2:00 AM	338	247	585	2:00 PM	2,719	2,706	5,425
3:00 AM	232	217	448	3:00 PM	2,984	2,827	5,811
4:00 AM	178	292	469	4:00 PM	3,587	3,190	6,777
5:00 AM	234	530	764	5:00 PM	4,081	3,522	7,602
6:00 AM	608	1,090	1,699	6:00 PM	4,141	3,610	7,751
7:00 AM	1,653	2,407	4,060	7:00 PM	3,288	2,923	6,210
8:00 AM	2,956	3,537	6,493	8:00 PM	2,287	1,974	4,261
9:00 AM	2,942	3,475	6,417	9:00 PM	1,739	1,579	3,318
10:00 AM	2,476	2,778	5,255	10:00 PM	1,429	1,292	2,721
11:00 AM	2,407	2,435	4,842	11:00 PM	1,188	959	2,147
12:00 PM	2,494	2,508	5,002	12:00 AM	889	699	1,588

Total Northbound	48,152
Total Southbound	47,823
Total Weekday	95,976

Curry Ford Mainline Toll Facility

Toll Facility Peak Hour Characteristic Summary Typical Average Weekday (Monday through Friday) - April 2017

Average Weekday Traffic Summary (unadjusted)

Average Weekday Total Traffic	105,970
Northbound Directional Traffic	53,142
Southbound Directional Traffic	52,828

Morning Peak Hour Summary (7:00 a.m. to 8:00 a.m.)

Northbound Directional Traffic	3,942
Southbound Directional Traffic	4,660
Total AM Peak Hour Traffic	8,602

AM Peak Hour Factor ("K") = Total Peak Hour Traffic / Average Weekday Total Traffic

AM Peak Hour Factor ("K_{am}") 8.12%

AM Peak Hour Directional Factor ("D") = Peak Directional Traffic / Total Peak Hour Traffic

AM Peak Hour Directional Factor ("D_{am}") 54.17%

Evening Peak Hour Summary (5:00 p.m. to 6:00 p.m.)

Northbound Directional Traffic	4,802
Southbound Directional Traffic	4,187
Total PM Peak Hour Traffic	8,989

PM Peak Hour Factor ("K") = Total Peak Hour Traffic / Average Weekday Total Traffic

PM Peak Hour Factor ("K_{pm}") 8.48%

PM Peak Hour Directional Factor ("D") = Peak Directional Traffic / Total Peak Hour Traffic

PM Peak Hour Directional Factor ("D_{pm}") 53.42%

Curry Ford Mainline Toll Facility

Toll Transaction Summary

Typical Average Weekday (Monday through Friday) - April 2017

Average Weekday Summary

Direction of Travel	E-PASS (AVI)		ACM (Coin)		Manual (Cash)		Total	
	Volume	% Usage	Volume	% Usage	Volume	% Usage	Traffic	% Usage
Northbound	48,750	92%	1,147	2%	3,245	6%	53,142	100%
Southbound	48,545	92%	1,059	2%	3,224	6%	52,828	100%

Morning Peak Hour Summary (7:00 a.m. to 8:00 a.m.)

Direction of Travel	E-PASS (AVI)		ACM (Coin)		Manual (Cash)		Total	
	Volume	% Usage	Volume	% Usage	Volume	% Usage	Traffic	% Usage
Northbound	3,753	95%	40	1%	149	4%	3,942	100%
Southbound	4,406	95%	66	1%	188	4%	4,660	100%

Evening Peak Hour Summary (5:00 p.m. to 6:00 p.m.)

Direction of Travel	E-PASS (AVI)		ACM (Coin)		Manual (Cash)		Total	
	Volume	% Usage	Volume	% Usage	Volume	% Usage	Traffic	% Usage
Northbound	4,449	93%	120	2%	233	5%	4,802	100%
Southbound	3,865	92%	86	2%	236	6%	4,187	100%

Curry Ford Mainline Toll Facility
SR 417 - Central Florida Greeneway
Historical & Existing Total Revenue Transactions Statistics

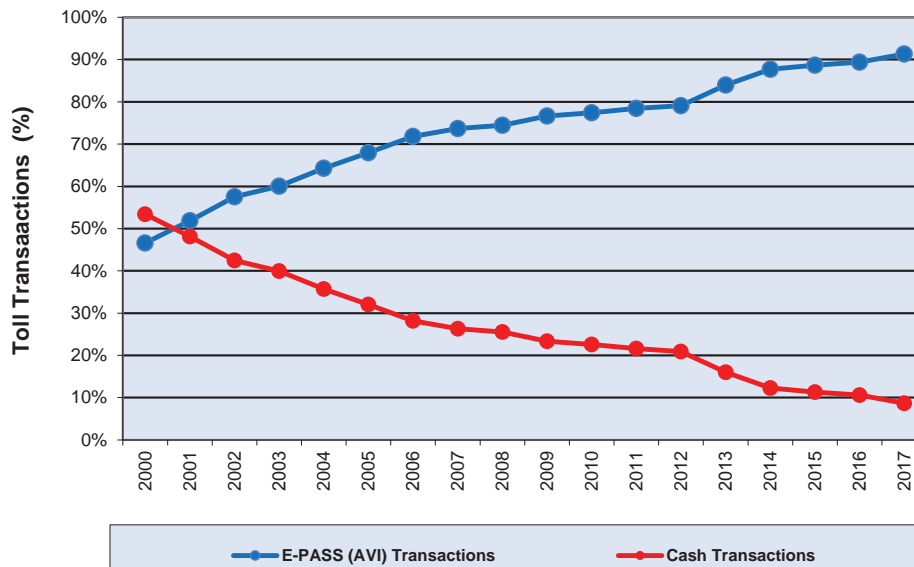

Year	Yearly Revenue Transaction		% Violations ⁽²⁾ (Percent of Total Transactions)
	% E-PASS (AVI) Transactions	% Cash Transactions	
2000	46.6%	53.4%	2.5%
2001	51.8%	48.2%	2.1%
2002	57.5%	42.5%	1.5%
2003	60.0%	40.0%	1.8%
2004	64.3%	35.7%	2.2%
2005	67.9%	32.1%	2.9%
2006	71.8%	28.2%	2.6%
2007	73.7%	26.3%	2.4%
2008	74.4%	25.6%	2.4%
2009	76.7%	23.3%	5.0%
2010	77.4%	22.6%	2.6%
2011	78.4%	21.6%	2.8%
2012	79.1%	20.9%	3.2%
2013	84.0%	16.0%	3.6%
2014	87.7%	12.3%	4.5%
2015	88.7%	11.3%	5.3%
2016	89.4%	10.6%	6.2%
2017	91.3%	8.7%	8.5%

1. All plazas had tolls suspended from 9/5/17 until 9/21/17 due to Hurricane Irma

2. Calculated as percent of Total Transactions, which is equal to Revenue Transactions plus Violations

University Mainline Toll Facility (Central Florida GreeneWay)



2017 Traffic Data and Statistics Manual
CENTRAL FLORIDA EXPRESSWAY AUTHORITY

OSCEOLA



Admin.
Blg.

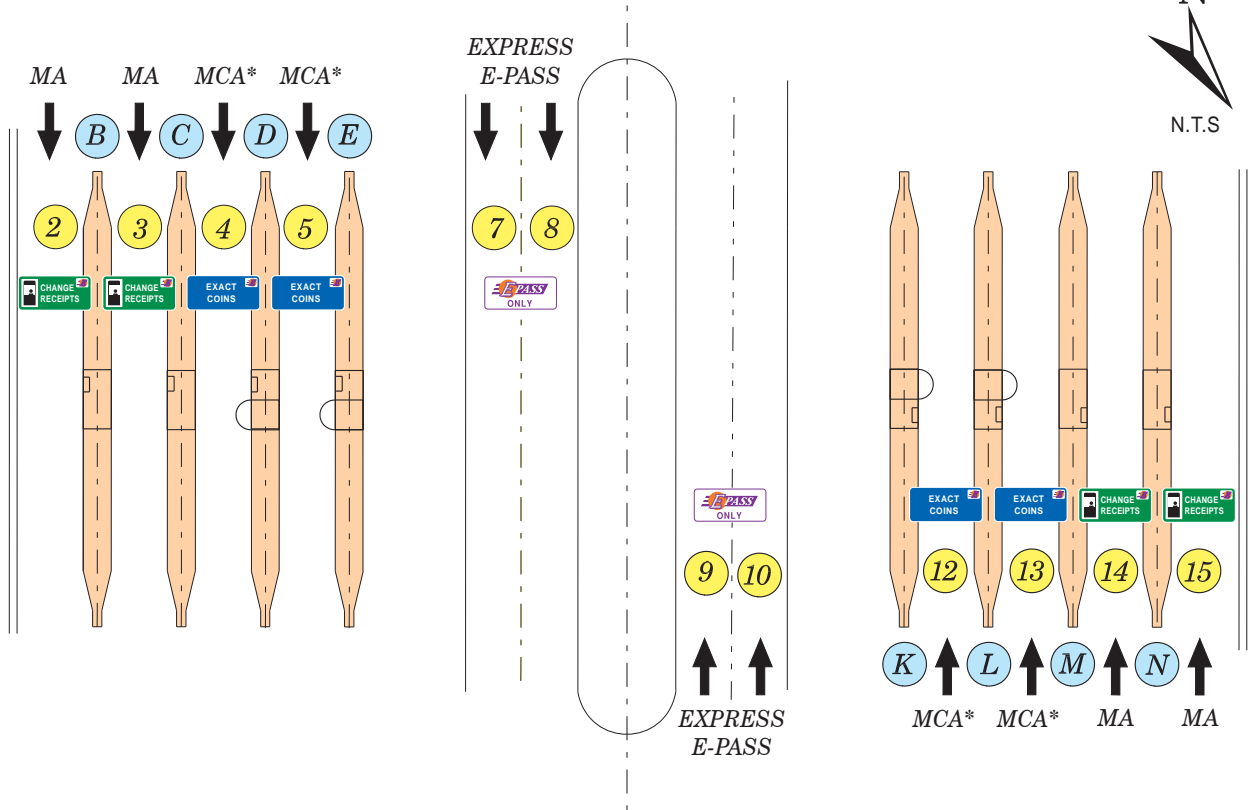

HISTORIC TRAFFIC - A.A.W.T.

1992	15,910 (POST-TOLL)	2015	86,650
1993	19,370	2016	95,670
1994	26,420	2017	103,030
1995	31,500		
1996	37,300		
1997	38,730		
1998	44,610		
1999	49,900		
2000	53,240		
2001	56,370		
2002	60,650		
2003	68,590		
2004	77,940		
2005	79,700		
2006	81,600		
2007	82,800		
2008	75,600		
2009	70,500 (Toll Increase April 2009)		
2010	72,900		
2011	74,900		
2012	72,750 (Toll Increase July 2012)		
2013	71,670		
2014	74,080		

TOLL RATE STRUCTURE **

	E-PASS	CASH
2 Axles	\$.82	\$ 1.00
3 Axles	\$ 1.64	\$ 1.75
4 Axles	\$ 1.91	\$ 2.00
5 Axles or more	\$ 2.46	\$ 2.50

LANES OF EQUIPMENT

- 4 Express E-PASS (E-PASS only)
- 4 Booths with Automated Coin Machines with E-PASS (MCA)
- 4 Manned Booths with E-PASS (MA)
- * Changeable Message Sign

LEGEND

- ① Lane Number
- Ⓐ Island Designation



Approx. Scale: 1" = 200'
January 2017

University Mainline Toll Facility SR 417 - Central Florida Greeneway

Fiscal Year 2017 Monthly Mainline & Ramp Toll Transactions and Revenue Summary

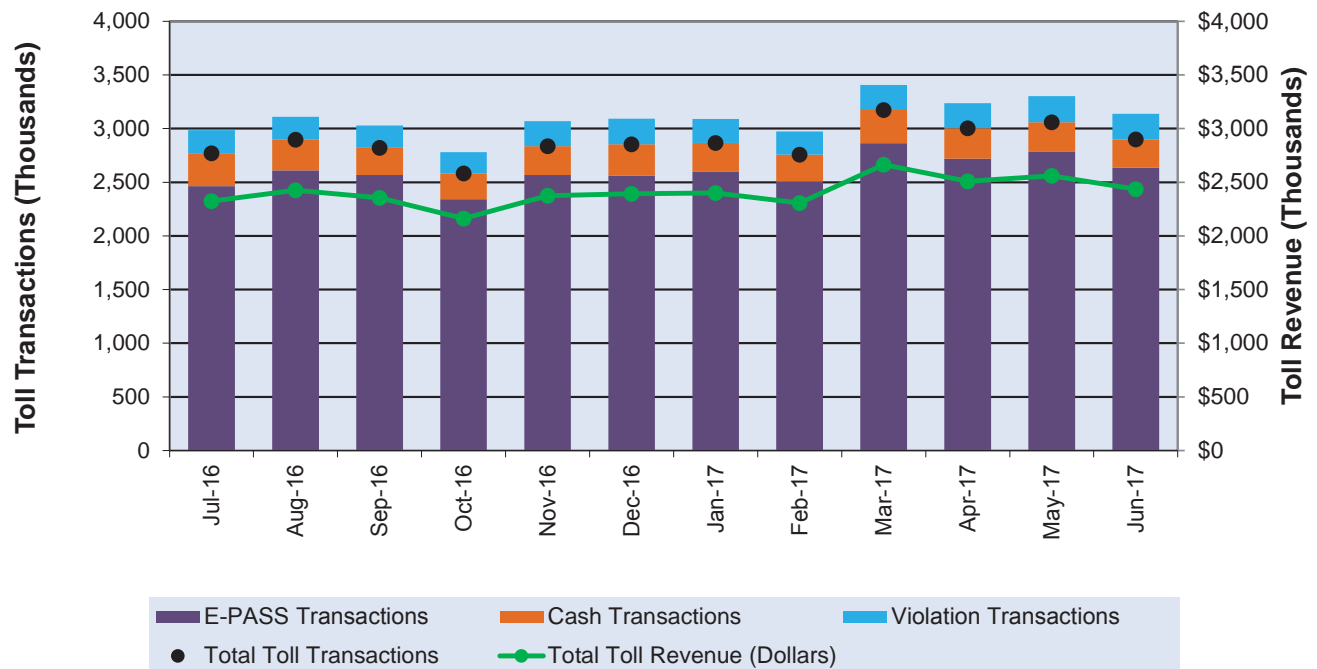

Month	FY 17 MONTHLY MAINLINE & RAMP TOLL TRANSACTIONS					Total Toll Revenue
	E-PASS	Cash	Total Revenue	Violations	Total	
July-16	2,463,142	307,111	2,770,253	216,115	2,986,368	\$2,323,462
August-16	2,609,634	286,813	2,896,447	213,518	3,109,965	\$2,426,115
September-16	2,566,740	253,809	2,820,549	206,804	3,027,353	\$2,355,361
October-16	2,342,667	239,215	2,581,882	198,398	2,780,280	\$2,160,840
November-16	2,567,107	268,546	2,835,653	234,056	3,069,709	\$2,374,127
December-16	2,561,541	292,498	2,854,039	237,655	3,091,694	\$2,393,205
January-17	2,600,683	265,356	2,866,039	222,327	3,088,366	\$2,400,397
February-17	2,505,680	251,165	2,756,845	216,438	2,973,283	\$2,306,357
March-17	2,862,918	309,119	3,172,037	233,962	3,405,999	\$2,662,360
April-17	2,718,522	284,571	3,003,093	232,458	3,235,551	\$2,509,812
May-17	2,782,755	275,138	3,057,893	244,134	3,302,027	\$2,560,775
June-17	2,636,661	263,458	2,900,119	237,716	3,137,835	\$2,435,951
Yearly Totals	31,218,050	3,296,799	34,514,849	2,693,581	37,208,430	\$28,908,762

Note: Data includes ramp toll plazas that report to the University Mainline Toll Plaza.

1. Cash transactions were calculated as the difference between total revenue traffic and E-PASS traffic
2. All plazas had tolls suspended in FY 17 due to Hurricane Matthew from 10/5/16 until early on 10/10/16



University Mainline Toll Facility
SR 417 - Central Florida GreeneWay
Typical Daily Expressway Traffic Volumes - April 2017

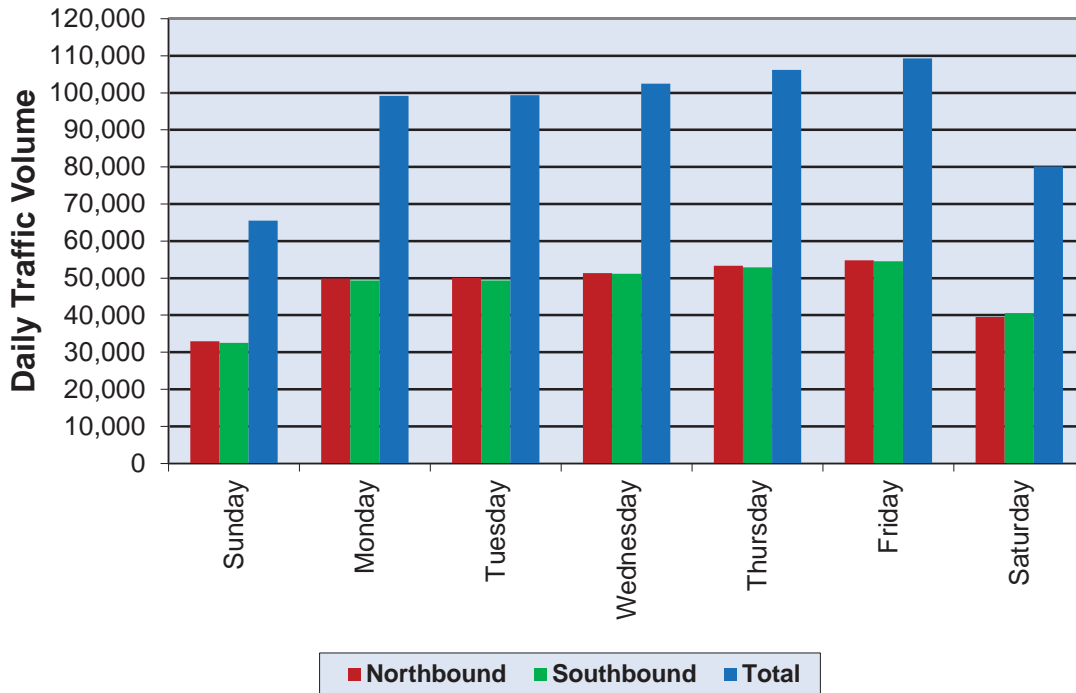

Day	Expressway Traffic Volumes		
	Northbound	Southbound	Total
Sunday	32,990	32,490	65,480
Monday	49,880	49,350	99,230
Tuesday	50,050	49,350	99,400
Wednesday	51,320	51,160	102,480
Thursday	53,310	52,920	106,230
Friday	54,800	54,530	109,330
Saturday	39,490	40,590	80,080

University Mainline Toll Facility
SR 417 - Central Florida GreenWay
Typical Average Five Day Hourly Traffic - April 2017

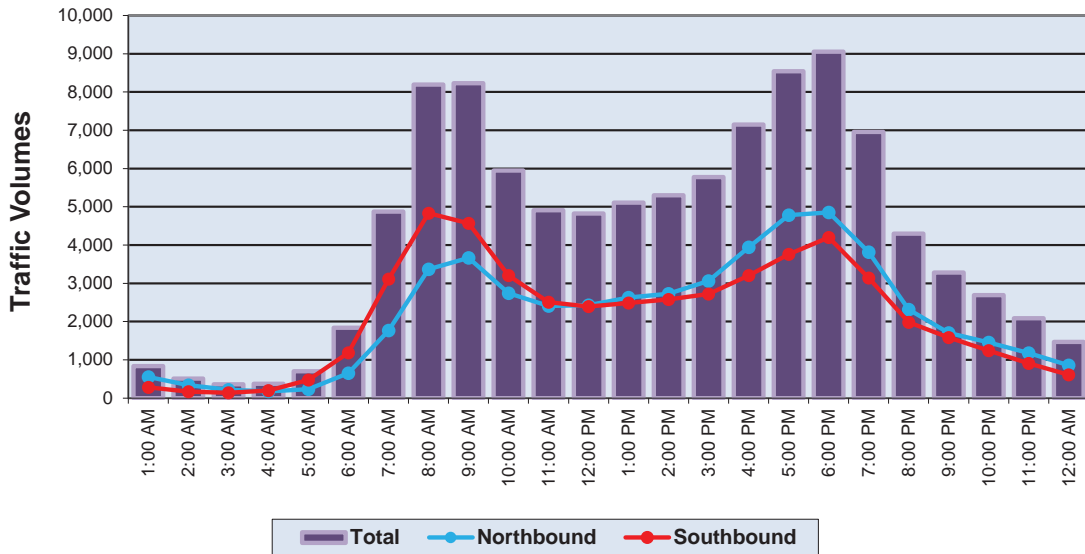

Hour Ending	Average Weekday Volumes		
	Northbound	Southbound	Total
1:00 AM	552	282	834
2:00 AM	338	171	509
3:00 AM	221	142	363
4:00 AM	175	199	374
5:00 AM	233	471	704
6:00 AM	653	1,184	1,837
7:00 AM	1,766	3,109	4,875
8:00 AM	3,368	4,829	8,197
9:00 AM	3,666	4,566	8,232
10:00 AM	2,742	3,204	5,946
11:00 AM	2,404	2,508	4,912
12:00 PM	2,430	2,393	4,823

Hour Ending	Average Weekday Volumes		
	Northbound	Southbound	Total
1:00 PM	2,628	2,482	5,110
2:00 PM	2,726	2,577	5,303
3:00 PM	3,060	2,718	5,778
4:00 PM	3,946	3,206	7,152
5:00 PM	4,783	3,758	8,541
6:00 PM	4,854	4,200	9,054
7:00 PM	3,816	3,139	6,955
8:00 PM	2,316	1,983	4,299
9:00 PM	1,705	1,580	3,285
10:00 PM	1,454	1,240	2,694
11:00 PM	1,179	908	2,087
12:00 AM	858	608	1,466

Total Northbound	51,873
Total Southbound	51,457
Total Weekday	103,330

University Mainline Toll Facility
SR 417 - Central Florida GreeneWay
Typical Average Seven Day Hourly Traffic - April 2017

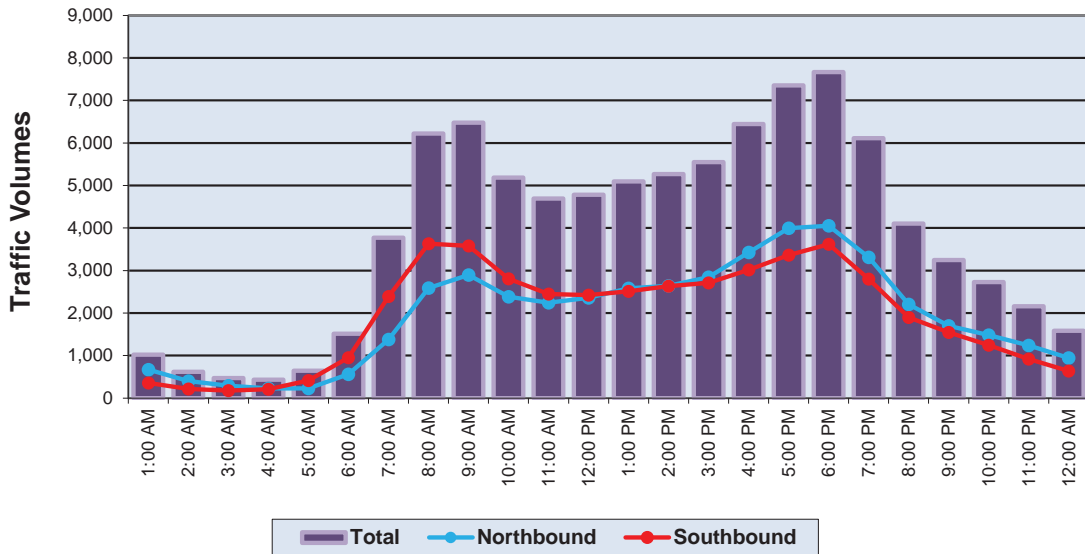

Hour Ending	Average Weekday Volumes		
	Northbound	Southbound	Total
1:00 AM	667	353	1,019
2:00 AM	403	212	616
3:00 AM	295	179	474
4:00 AM	226	206	431
5:00 AM	228	414	642
6:00 AM	562	952	1,514
7:00 AM	1,383	2,389	3,771
8:00 AM	2,591	3,630	6,221
9:00 AM	2,896	3,583	6,479
10:00 AM	2,381	2,803	5,184
11:00 AM	2,242	2,449	4,690
12:00 PM	2,358	2,424	4,782

Hour Ending	Average Weekday Volumes		
	Northbound	Southbound	Total
1:00 PM	2,583	2,514	5,097
2:00 PM	2,640	2,633	5,272
3:00 PM	2,844	2,707	5,551
4:00 PM	3,425	3,020	6,446
5:00 PM	3,996	3,360	7,356
6:00 PM	4,054	3,617	7,670
7:00 PM	3,315	2,798	6,113
8:00 PM	2,204	1,898	4,102
9:00 PM	1,702	1,545	3,247
10:00 PM	1,483	1,243	2,726
11:00 PM	1,240	919	2,159
12:00 AM	942	639	1,581

Total Northbound	46,660
Total Southbound	46,486
Total Weekday	93,146

University Mainline Toll Facility

Toll Facility Peak Hour Characteristic Summary Typical Average Weekday (Monday through Friday) - April 2017

Average Weekday Traffic Summary (unadjusted)

Average Weekday Total Traffic	103,330
Northbound Directional Traffic	51,873
Southbound Directional Traffic	51,457

Morning Peak Hour Summary (7:00 a.m. to 8:00 a.m.)

Northbound Directional Traffic	3,666
Southbound Directional Traffic	4,566
Total AM Peak Hour Traffic	8,232

AM Peak Hour Factor ("K") = Total Peak Hour Traffic / Average Weekday Total Traffic

AM Peak Hour Factor ("K_{am}") **7.97%**

AM Peak Hour Directional Factor ("D") = Peak Directional Traffic / Total Peak Hour Traffic

AM Peak Hour Directional Factor ("D_{am}") **55.47%**

Evening Peak Hour Summary (5:00 p.m. to 6:00 p.m.)

Northbound Directional Traffic	4,854
Southbound Directional Traffic	4,200
Total PM Peak Hour Traffic	9,054

PM Peak Hour Factor ("K") = Total Peak Hour Traffic / Average Weekday Total Traffic

PM Peak Hour Factor ("K_{pm}") **8.76%**

PM Peak Hour Directional Factor ("D") = Peak Directional Traffic / Total Peak Hour Traffic

PM Peak Hour Directional Factor ("D_{pm}") **53.61%**

University Mainline Toll Facility

Toll Transaction Summary

Typical Average Weekday (Monday through Friday) - April 2017

Average Weekday Summary

Direction of Travel	E-PASS (AVI)		ACM (Coin)		Manual (Cash)		Total	
	Volume	% Usage	Volume	% Usage	Volume	% Usage	Traffic	% Usage
Northbound	44,528	86%	4,016	8%	3,329	6%	51,873	100%
Southbound	46,265	90%	2,076	4%	3,116	6%	51,457	100%

Morning Peak Hour Summary (7:00 a.m. to 8:00 a.m.)

Direction of Travel	E-PASS (AVI)		ACM (Coin)		Manual (Cash)		Total	
	Volume	% Usage	Volume	% Usage	Volume	% Usage	Traffic	% Usage
Northbound	3,278	89%	219	6%	169	5%	3,666	100%
Southbound	4,002	88%	373	8%	191	4%	4,566	100%

Evening Peak Hour Summary (5:00 p.m. to 6:00 p.m.)

Direction of Travel	E-PASS (AVI)		ACM (Coin)		Manual (Cash)		Total	
	Volume	% Usage	Volume	% Usage	Volume	% Usage	Traffic	% Usage
Northbound	3,711	76%	909	19%	234	5%	4,854	100%
Southbound	3,782	90%	177	4%	241	6%	4,200	100%

University Mainline Toll Facility
SR 417 - Central Florida GreenWay
Historical & Existing Total Revenue Transactions Statistics

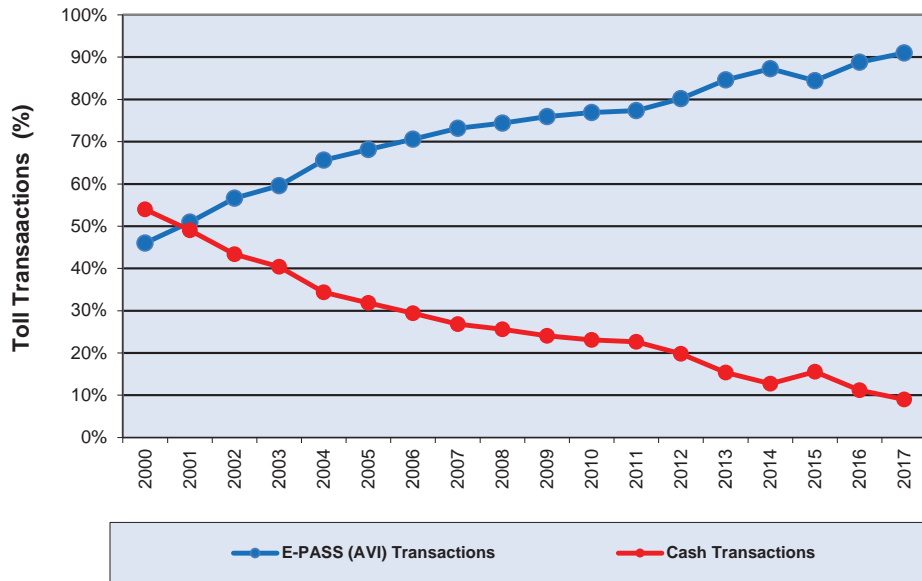

Year	Yearly Revenue Transaction		% Violations ⁽²⁾ (Percent of Total Transactions)
	% E-PASS (AVI) Transactions	% Cash Transactions	
2000	46.0%	54.0%	2.6%
2001	51.0%	49.0%	2.6%
2002	56.7%	43.3%	2.0%
2003	59.6%	40.4%	2.2%
2004	65.7%	34.3%	2.5%
2005	68.2%	31.8%	2.9%
2006	70.6%	29.4%	2.6%
2007	73.2%	26.8%	2.6%
2008	74.4%	25.6%	2.6%
2009	75.9%	24.1%	3.0%
2010	76.9%	23.1%	2.9%
2011	77.4%	22.6%	2.8%
2012	80.2%	19.8%	3.0%
2013	84.6%	15.4%	3.3%
2014	87.3%	12.7%	4.0%
2015	84.4%	15.6%	4.6%
2016	88.8%	11.2%	5.7%
2017	91.0%	9.0%	8.0%

1. All plazas had tolls suspended from 9/5/17 until 9/21/17 due to Hurricane Irma

2. Calculated as percent of Total Transactions, which is equal to Revenue Transactions plus Violations

Independence Mainline Toll Facility (Western Beltway)



2017 Traffic Data and Statistics Manual
CENTRAL FLORIDA EXPRESSWAY AUTHORITY

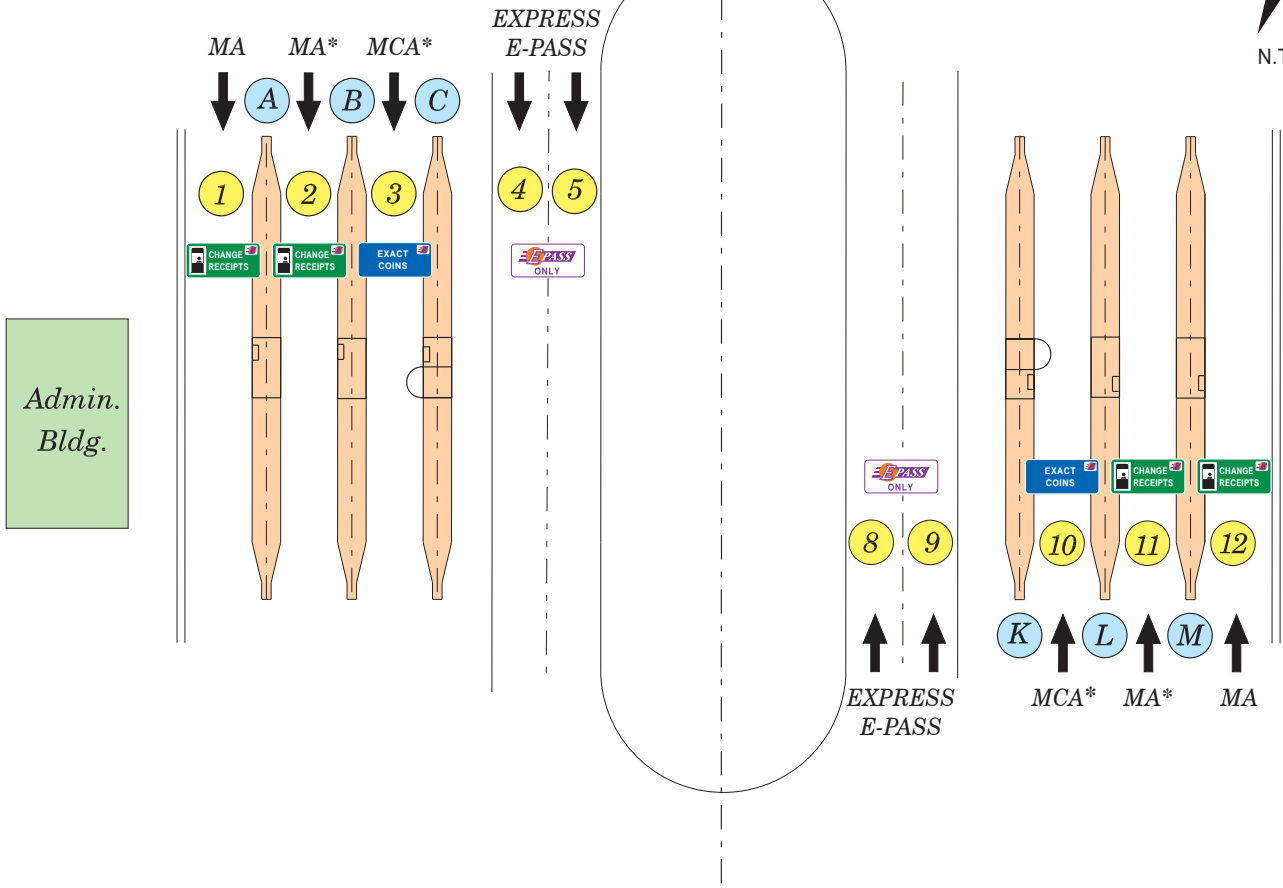

HISTORIC TRAFFIC - A.A.W.T.

2006	8,400
2007	14,000
2008	13,500
2009	12,500 (Toll Increase April 2009)
2010	13,700
2011	14,130
2012	15,930 (Toll Increase July 2012)
2013	16,620
2014	19,520
2015	26,200
2016	31,570
2017	41,260

TOLL RATE STRUCTURE **

	<u>E-PASS</u>	<u>CASH</u>
2 Axles	\$ 1.37	\$ 1.50
3 Axles	\$ 1.91	\$ 2.00
4 Axles	\$ 2.46	\$ 2.50
5 Axles or more	\$ 3.00	\$ 3.00

LANES OF EQUIPMENT

- 4 Manned Booths with E-PASS (MA)
- 2 Booths with Automated Coin Machines and E-PASS
- 4 Express E-PASS (E-PASS only)
- * Changeable Message Sign

LEGEND

- ① Lane Number
- Ⓐ Island Designation



**SR 429 (WESTERN BELTWAY)
Independence Mainline Toll Facility**

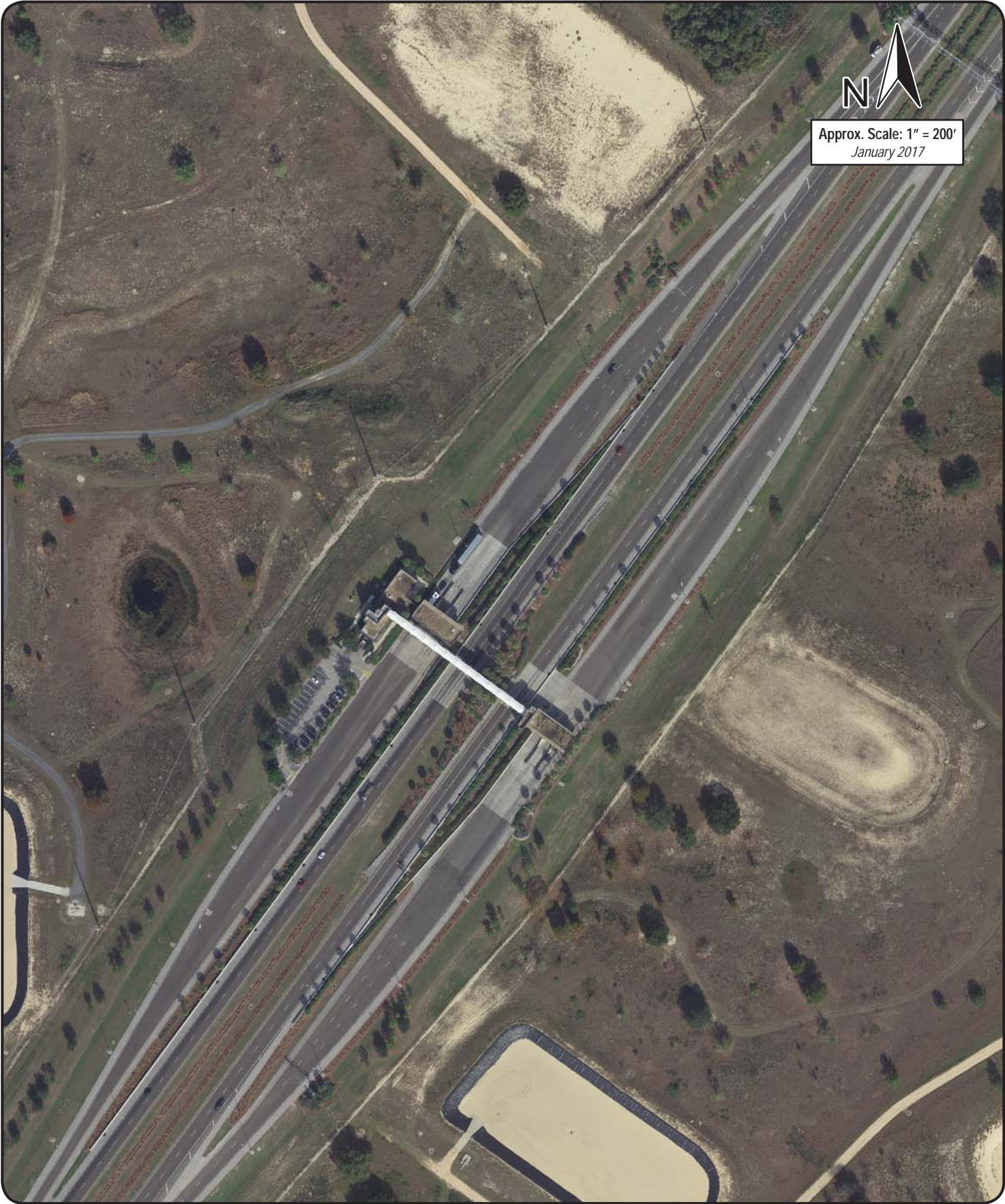

Approx. Scale: 1" = 200'
January 2017

Independence Mainline Toll Facility

SR 429 - Western Beltway

Fiscal Year 2017 Monthly Mainline & Ramp Toll Transactions and Revenue Summary

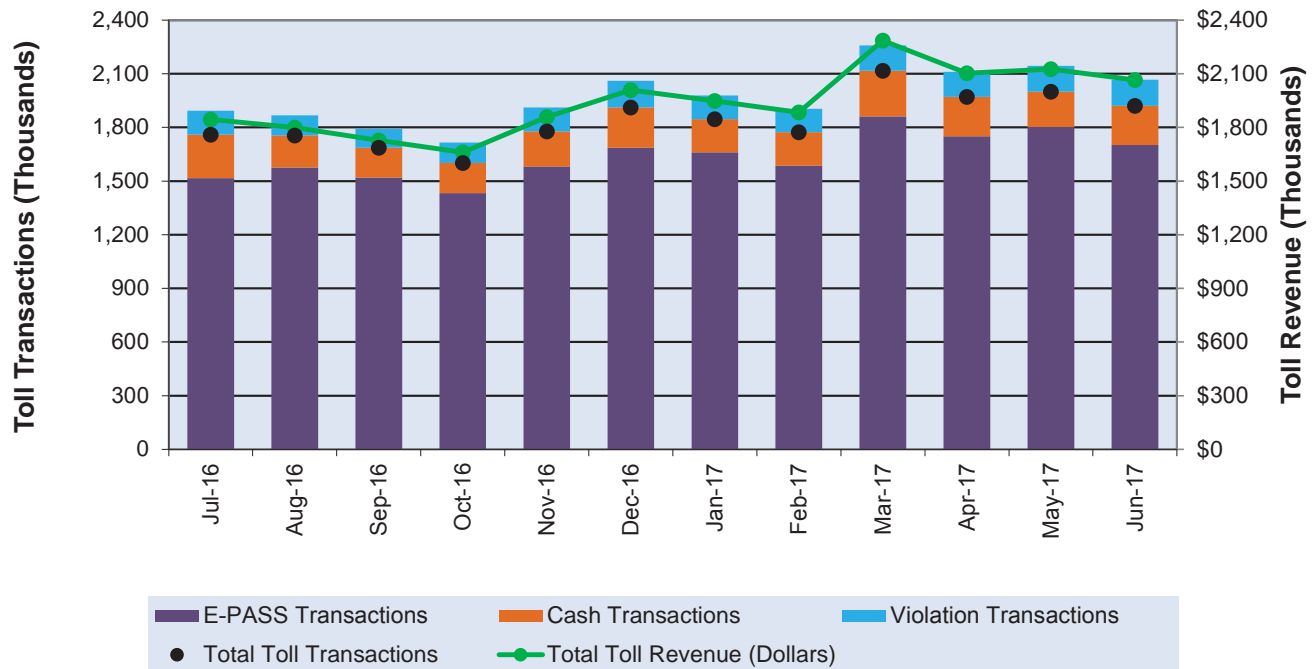

Month	FY 17 MONTHLY MAINLINE & RAMP TOLL TRANSACTIONS					Total Toll Revenue
	E-PASS	Cash	Total Revenue	Violations	Total	
July-16	1,515,679	243,093	1,758,772	134,853	1,893,625	\$1,844,566
August-16	1,575,347	179,384	1,754,731	112,892	1,867,623	\$1,798,397
September-16	1,519,540	167,180	1,686,720	105,092	1,791,812	\$1,727,680
October-16	1,433,009	167,873	1,600,882	114,738	1,715,620	\$1,661,045
November-16	1,581,664	196,330	1,777,994	133,671	1,911,665	\$1,857,521
December-16	1,685,712	226,197	1,911,909	148,652	2,060,561	\$2,009,102
January-17	1,660,718	185,718	1,846,436	132,354	1,978,790	\$1,947,294
February-17	1,586,679	186,508	1,773,187	130,245	1,903,432	\$1,883,646
March-17	1,861,482	254,946	2,116,428	141,084	2,257,512	\$2,285,201
April-17	1,750,677	219,420	1,970,097	140,022	2,110,119	\$2,102,645
May-17	1,801,182	198,533	1,999,715	144,525	2,144,240	\$2,126,047
June-17	1,701,798	218,867	1,920,665	146,105	2,066,770	\$2,064,946
Yearly Totals	19,673,487	2,444,049	22,117,536	1,584,233	23,701,769	\$23,308,090

Note: Data includes ramp toll plazas that report to the Independence Mainline Toll Plaza.

1. Cash transactions were calculated as the difference between total revenue traffic and E-PASS traffic
2. All plazas had tolls suspended in FY 17 due to Hurricane Matthew from 10/5/16 until early on 10/10/16



SR 429 (WESTERN BELTWAY) Independence Mainline Toll Facility

SECTION III

Independence Mainline Toll Facility
SR 429 - Western Beltway
Typical Daily Traffic Volumes - April 2017

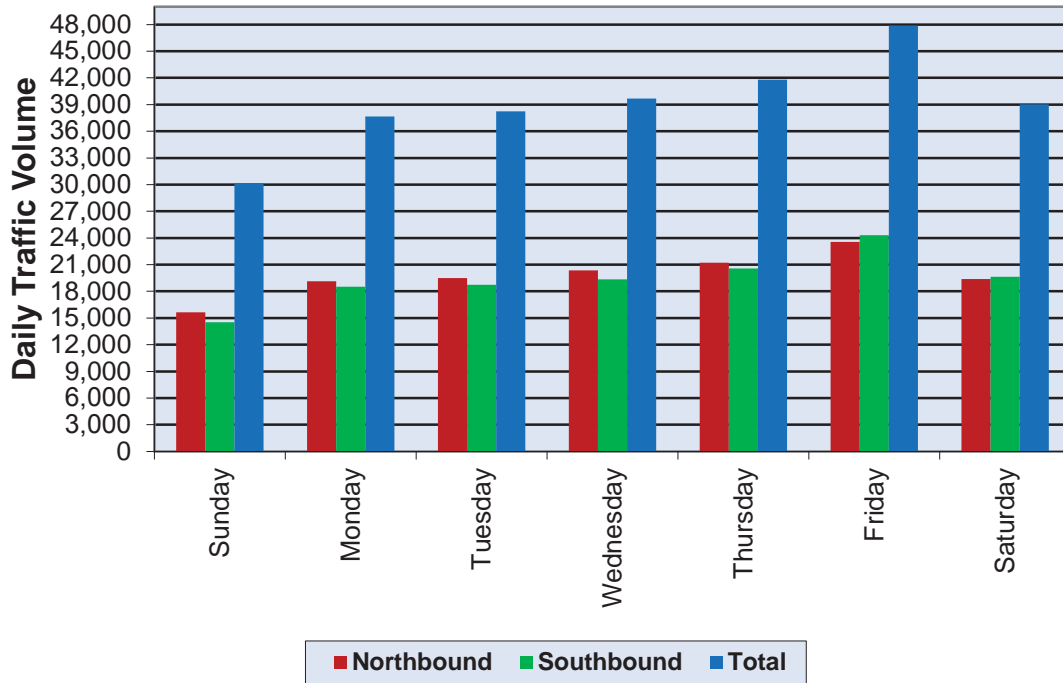

Day	Expressway Traffic Volumes		
	Northbound	Southbound	Total
Sunday	15,650	14,520	30,170
Monday	19,130	18,520	37,650
Tuesday	19,500	18,720	38,220
Wednesday	20,340	19,350	39,690
Thursday	21,220	20,570	41,790
Friday	23,560	24,310	47,870
Saturday	19,400	19,630	39,030

Independence Mainline Toll Facility SR 429 - Western Beltway Average Five Day Hourly Traffic - April 2017

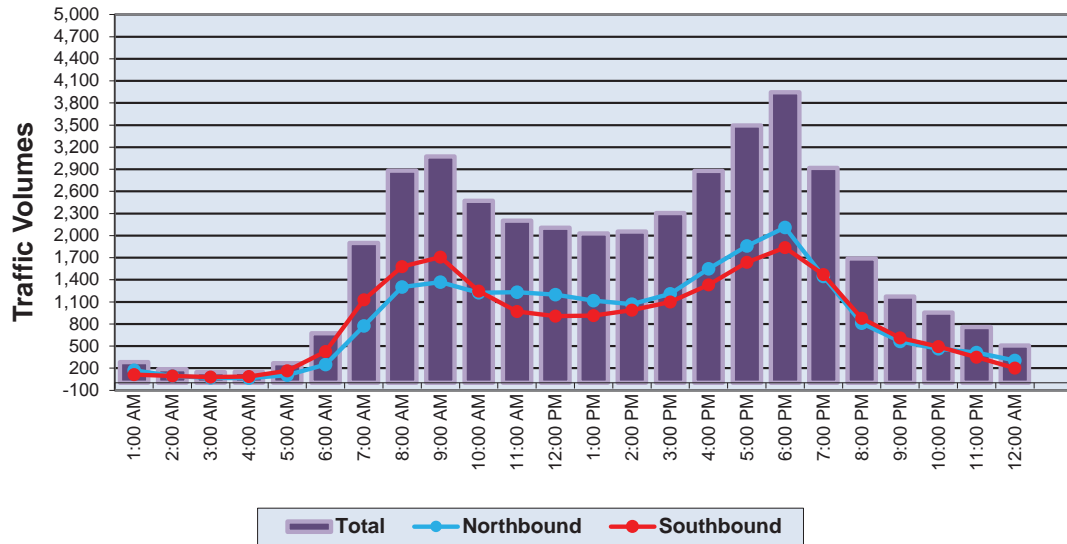

Hour Ending	Average Weekday Volumes		
	Northbound	Southbound	Total
1:00 AM	172	112	284
2:00 AM	93	93	186
3:00 AM	69	78	147
4:00 AM	66	85	151
5:00 AM	105	163	268
6:00 AM	248	426	674
7:00 AM	772	1,127	1,899
8:00 AM	1,303	1,578	2,881
9:00 AM	1,368	1,707	3,075
10:00 AM	1,225	1,246	2,471
11:00 AM	1,232	969	2,201
12:00 PM	1,199	908	2,107

Hour Ending	Average Weekday Volumes		
	Northbound	Southbound	Total
1:00 PM	1,115	912	2,027
2:00 PM	1,067	988	2,055
3:00 PM	1,208	1,098	2,306
4:00 PM	1,547	1,332	2,879
5:00 PM	1,857	1,638	3,495
6:00 PM	2,109	1,835	3,944
7:00 PM	1,445	1,472	2,917
8:00 PM	812	878	1,690
9:00 PM	562	611	1,173
10:00 PM	463	492	955
11:00 PM	413	347	760
12:00 AM	304	202	506

Total Northbound	20,754
Total Southbound	20,297
Total Weekday	41,051

Independence Mainline Toll Facility

SR 429 - Western Beltway

Average Seven Day Hourly Traffic - April 2017

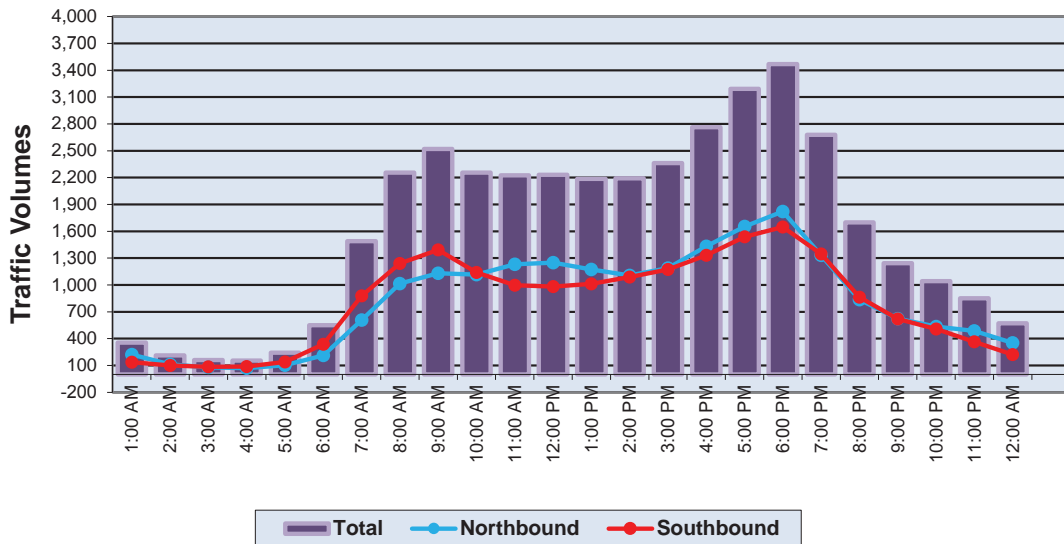

Hour Ending	Average Weekday Volumes		
	Northbound	Southbound	Total
1:00 AM	221	135	356
2:00 AM	112	100	212
3:00 AM	78	84	162
4:00 AM	69	86	155
5:00 AM	102	140	242
6:00 AM	212	337	549
7:00 AM	609	879	1,488
8:00 AM	1,015	1,239	2,255
9:00 AM	1,130	1,390	2,521
10:00 AM	1,116	1,138	2,254
11:00 AM	1,230	995	2,225
12:00 PM	1,249	982	2,231

Hour Ending	Average Weekday Volumes		
	Northbound	Southbound	Total
1:00 PM	1,172	1,013	2,185
2:00 PM	1,106	1,087	2,192
3:00 PM	1,188	1,174	2,362
4:00 PM	1,431	1,333	2,764
5:00 PM	1,654	1,538	3,192
6:00 PM	1,819	1,648	3,468
7:00 PM	1,331	1,346	2,677
8:00 PM	836	863	1,699
9:00 PM	622	621	1,243
10:00 PM	536	506	1,042
11:00 PM	486	366	852
12:00 AM	351	220	572

Total Northbound	19,676
Total Southbound	19,222
Total Weekday	38,897

Independence Mainline Toll Facility

Toll Transaction Summary

Typical Average Weekday (Monday through Friday) - April 2017

Average Weekday Summary

Direction of Travel	E-PASS (AVI)		ACM (Coin)		Manual (Cash)		Total	
	Volume	% Usage	Volume	% Usage	Volume	% Usage	Traffic	% Usage
Northbound	18,215	88%	414	2%	2,125	10%	20,754	100%
Southbound	17,870	88%	404	2%	2,023	10%	20,297	100%

Morning Peak Hour Summary (7:00 a.m. to 8:00 a.m.)

Direction of Travel	E-PASS (AVI)		ACM (Coin)		Manual (Cash)		Total	
	Volume	% Usage	Volume	% Usage	Volume	% Usage	Traffic	% Usage
Northbound	1,235	90%	19	1%	114	8%	1,368	100%
Southbound	1,587	93%	17	1%	103	6%	1,707	100%

Evening Peak Hour Summary (5:00 p.m. to 6:00 p.m.)

Direction of Travel	E-PASS (AVI)		ACM (Coin)		Manual (Cash)		Total	
	Volume	% Usage	Volume	% Usage	Volume	% Usage	Traffic	% Usage
Northbound	1,905	90%	36	2%	168	8%	2,109	100%
Southbound	1,612	88%	45	2%	178	10%	1,835	100%

Independence Mainline Toll Facility
SR 429 - Western Beltway
Historical & Existing Total Revenue Transactions Statistics

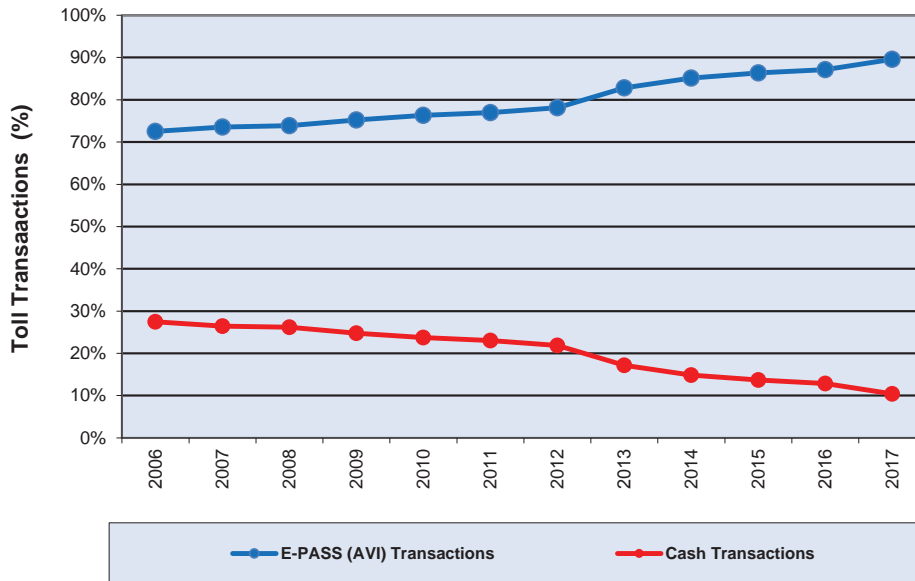

Year	Yearly Revenue Transaction		% Violations ⁽²⁾ (Percent of Total Transactions)
	% E-PASS (AVI) Transactions	% Cash Transactions	
2000	Not Open to Traffic		
2001	Not Open to Traffic		
2002	Not Open to Traffic		
2003	Not Open to Traffic		
2004	Not Open to Traffic		
2005	Not Open to Traffic		
2006	72.5%	27.5%	2.2%
2007	73.5%	26.5%	2.1%
2008	73.8%	26.2%	2.1%
2009	75.2%	24.8%	2.5%
2010	76.3%	23.7%	2.3%
2011	76.9%	23.1%	2.2%
2012	78.1%	21.9%	2.5%
2013	82.8%	17.2%	3.0%
2014	85.1%	14.9%	3.7%
2015	86.3%	13.7%	4.4%
2016	87.1%	12.9%	5.2%
2017	89.6%	10.4%	7.5%

1. All plazas had tolls suspended from 9/5/17 until 9/21/17 due to Hurricane Irma

2. Calculated as percent of Total Transactions, which is equal to Revenue Transactions plus Violations

Forest Lake Mainline Toll Facility (Western Beltway)



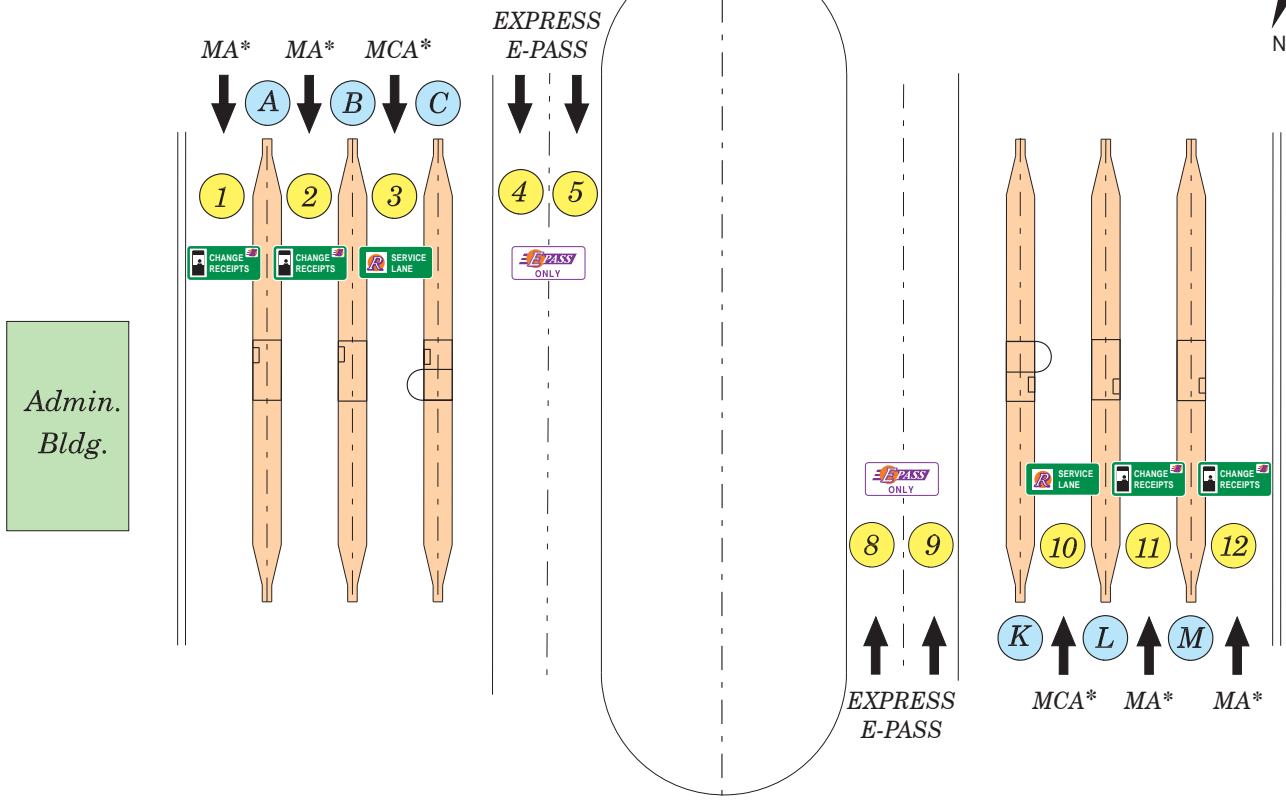

HISTORIC TRAFFIC - A.A.W.T.

2000	8,360
2001	13,620
2002	16,940
2003	20,140
2004	23,820
2005	27,900
2006	29,200
2007	30,410
2008	27,000
2009	27,600
2010	29,500 (Toll Increase April 2009)
2011	29,600
2012	31,650
2013	34,430 (Toll Increase July 2012)
2014	38,930
2015	46,360
2016	53,510
2017	61,000

TOLL RATE STRUCTURE		
	<u>E-PASS</u>	<u>CASH</u>
2 Axles	\$ 1.37	\$ 1.50
3 Axles	\$ 1.91	\$ 2.00
4 Axles	\$ 2.46	\$ 2.50
5 Axles or more	\$ 3.00	\$ 3.00

LANES OF EQUIPMENT

- 4 Manned Booths with E-PASS (MA)
- 2 Booths with ACM and E-PASS
- 4 Express E-PASS (E-PASS only)
- * Changeable Message Sign

LEGEND

- Lane Number
- Island Designation



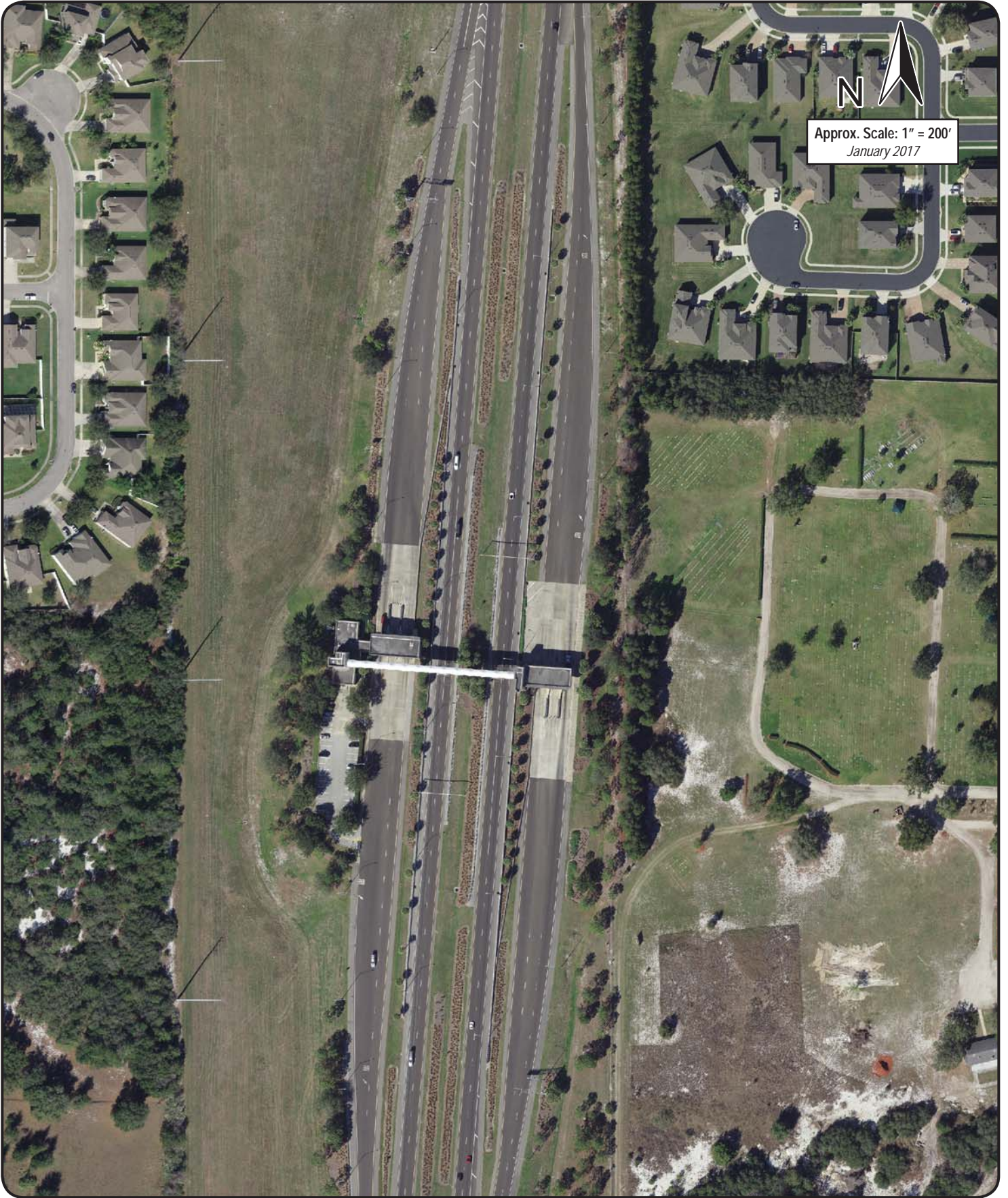

Approx. Scale: 1" = 200'
January 2017

Forest Lake Mainline Toll Facility

SR 429 - Western Beltway

Fiscal Year 2017 Monthly Mainline & Ramp Toll Transactions and Revenue Summary

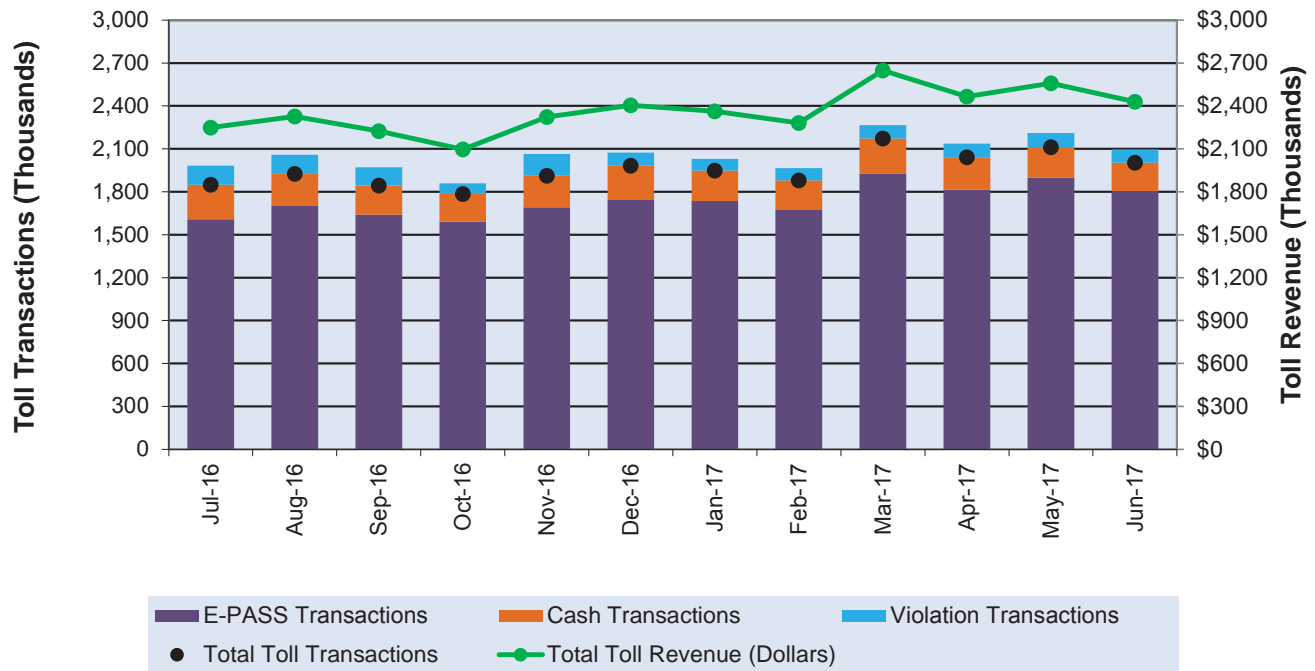

Month	FY 17 MONTHLY MAINLINE & RAMP TOLL TRANSACTIONS					Total Toll Revenue
	E-PASS	Cash	Total Revenue	Violations	Total	
July-16	1,608,710	241,402	1,850,112	133,211	1,983,323	\$2,247,889
August-16	1,704,116	221,190	1,925,306	132,840	2,058,146	\$2,325,911
September-16	1,640,895	202,390	1,843,285	127,057	1,970,342	\$2,223,004
October-16	1,590,922	192,844	1,783,766	74,237	1,858,003	\$2,095,663
November-16	1,691,652	220,501	1,912,153	151,679	2,063,832	\$2,322,322
December-16	1,746,180	235,927	1,982,107	91,323	2,073,430	\$2,404,545
January-17	1,734,525	213,199	1,947,724	82,994	2,030,718	\$2,362,983
February-17	1,672,033	207,536	1,879,569	86,277	1,965,846	\$2,280,081
March-17	1,925,645	247,547	2,173,192	91,878	2,265,070	\$2,647,000
April-17	1,815,881	225,289	2,041,170	95,094	2,136,264	\$2,464,470
May-17	1,898,130	213,297	2,111,427	99,686	2,211,113	\$2,557,602
June-17	1,803,574	199,107	2,002,681	92,871	2,095,552	\$2,428,732
Yearly Totals	20,832,263	2,620,229	23,452,492	1,259,147	24,711,639	\$28,360,202

Note: Data includes ramp toll plazas that report to the Forest Lake Mainline Toll Plaza.

1. Cash transactions were calculated as the difference between total revenue traffic and E-PASS traffic
2. All plazas had tolls suspended in FY 17 due to Hurricane Matthew from 10/5/16 until early on 10/10/16



Forest Lake Mainline Toll Facility
SR 429 - Western Beltway
Typical Daily Traffic Volumes - April 2017

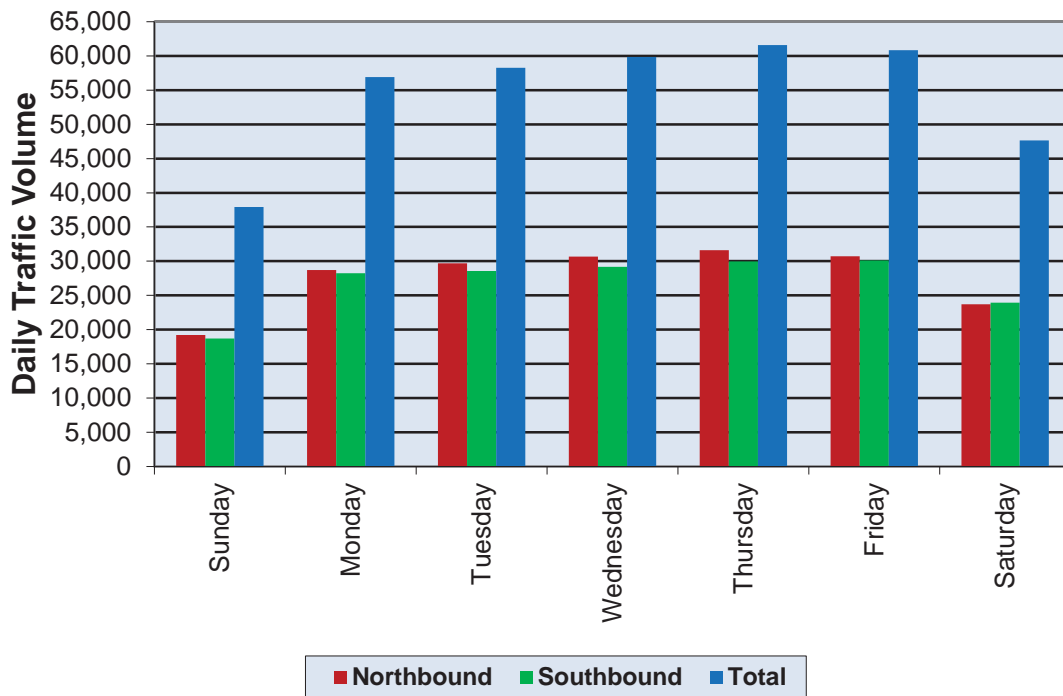

Day	Expressway Traffic Volumes		
	Northbound	Southbound	Total
Sunday	19,190	18,710	37,900
Monday	28,700	28,220	56,920
Tuesday	29,690	28,580	58,270
Wednesday	30,660	29,190	59,850
Thursday	31,600	29,990	61,590
Friday	30,730	30,120	60,850
Saturday	23,710	23,920	47,630

Forest Lake Mainline Toll Facility
SR 429 - Western Beltway
Average Five Day Hourly Traffic - April 2017

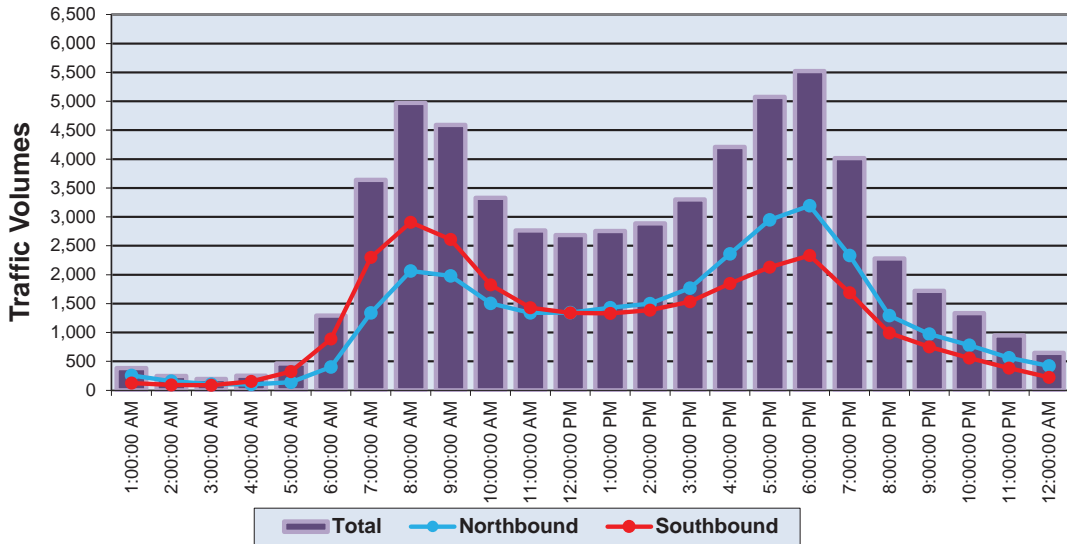

Hour Ending	Average Weekday Volumes		
	Northbound	Southbound	Total
1:00 AM	256	126	382
2:00 AM	158	90	248
3:00 AM	107	89	196
4:00 AM	100	151	251
5:00 AM	140	324	464
6:00 AM	403	889	1,292
7:00 AM	1,340	2,298	3,638
8:00 AM	2,063	2,907	4,970
9:00 AM	1,980	2,609	4,589
10:00 AM	1,505	1,823	3,328
11:00 AM	1,338	1,427	2,765
12:00 PM	1,343	1,340	2,683

Hour Ending	Average Weekday Volumes		
	Northbound	Southbound	Total
1:00 PM	1,426	1,329	2,755
2:00 PM	1,498	1,387	2,885
3:00 PM	1,766	1,533	3,299
4:00 PM	2,359	1,849	4,208
5:00 PM	2,946	2,129	5,075
6:00 PM	3,192	2,330	5,522
7:00 PM	2,330	1,688	4,018
8:00 PM	1,291	990	2,281
9:00 PM	973	749	1,722
10:00 PM	779	557	1,336
11:00 PM	564	384	948
12:00 AM	423	223	646

Total Northbound	30,280
Total Southbound	29,221
Total Weekday	59,501

Forest Lake Mainline Toll Facility
SR 429 - Western Beltway
Average Seven Day Hourly Traffic - April 2017

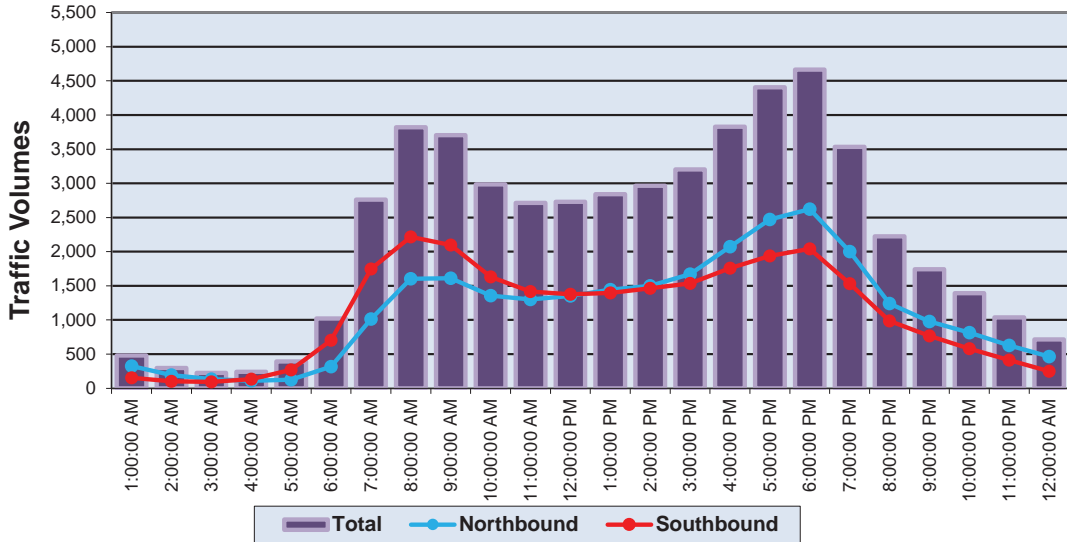

Hour Ending	Average Weekday Volumes		
	Northbound	Southbound	Total
1:00 AM	323	155	478
2:00 AM	194	101	295
3:00 AM	132	92	224
4:00 AM	109	133	242
5:00 AM	125	267	392
6:00 AM	317	703	1,020
7:00 AM	1,014	1,748	2,762
8:00 AM	1,603	2,217	3,820
9:00 AM	1,610	2,095	3,704
10:00 AM	1,355	1,630	2,986
11:00 AM	1,299	1,414	2,713
12:00 PM	1,352	1,377	2,729

Hour Ending	Average Weekday Volumes		
	Northbound	Southbound	Total
1:00 PM	1,444	1,397	2,841
2:00 PM	1,500	1,463	2,963
3:00 PM	1,670	1,535	3,205
4:00 PM	2,072	1,758	3,830
5:00 PM	2,471	1,937	4,408
6:00 PM	2,622	2,042	4,664
7:00 PM	2,002	1,531	3,533
8:00 PM	1,239	987	2,226
9:00 PM	976	765	1,741
10:00 PM	813	579	1,392
11:00 PM	628	411	1,039
12:00 AM	465	250	715

Total Northbound	27,334
Total Southbound	26,584
Total Weekday	53,919

Forest Lake Mainline Toll Facility

Toll Facility Peak Hour Characteristic Summary Typical Average Weekday (Monday through Friday) - April 2017

Average Weekday Traffic Summary (unadjusted)

Average Weekday Total Traffic	59,501
Northbound Directional Traffic	30,280
Southbound Directional Traffic	29,221

Morning Peak Hour Summary (7:00 a.m. to 8:00 a.m.)

Northbound Directional Traffic	2,063
Southbound Directional Traffic	2,907
Total AM Peak Hour Traffic	4,970

AM Peak Hour Factor ("K") = Total Peak Hour Traffic / Average Weekday Total Traffic

AM Peak Hour Factor ("K_{am}") 8.35%

AM Peak Hour Directional Factor ("D") = Peak Directional Traffic / Total Peak Hour Traffic

AM Peak Hour Directional Factor ("D_{am}") 58.49%

Evening Peak Hour Summary (5:00 p.m. to 6:00 p.m.)

Northbound Directional Traffic	3,192
Southbound Directional Traffic	2,330
Total PM Peak Hour Traffic	5,522

PM Peak Hour Factor ("K") = Total Peak Hour Traffic / Average Weekday Total Traffic

PM Peak Hour Factor ("K_{pm}") 9.28%

PM Peak Hour Directional Factor ("D") = Peak Directional Traffic / Total Peak Hour Traffic

PM Peak Hour Directional Factor ("D_{pm}") 57.81%

Forest Lake Mainline Toll Facility

Toll Transaction Summary

Typical Average Weekday (Monday through Friday) - April 2017

Average Weekday Summary

Direction of Travel	E-PASS (AVI)		ACM (Coin)		Manual (Cash)		Total	
	Volume	% Usage	Volume	% Usage	Volume	% Usage	Traffic	% Usage
Northbound	27,567	91%	473	2%	2,240	7%	30,280	100%
Southbound	26,484	91%	486	2%	2,251	8%	29,221	100%

Morning Peak Hour Summary (7:00 a.m. to 8:00 a.m.)

Direction of Travel	E-PASS (AVI)		ACM (Coin)		Manual (Cash)		Total	
	Volume	% Usage	Volume	% Usage	Volume	% Usage	Traffic	% Usage
Northbound	1,942	94%	17	1%	104	5%	2,063	100%
Southbound	2,704	93%	47	2%	156	5%	2,907	100%

Evening Peak Hour Summary (5:00 p.m. to 6:00 p.m.)

Direction of Travel	E-PASS (AVI)		ACM (Coin)		Manual (Cash)		Total	
	Volume	% Usage	Volume	% Usage	Volume	% Usage	Traffic	% Usage
Northbound	2,945	92%	51	2%	196	6%	3,192	100%
Southbound	2,125	91%	43	2%	162	7%	2,330	100%

Forest Lake Mainline Toll Facility
SR 429 - Western Beltway
Historical & Existing Total Revenue Transactions Statistics

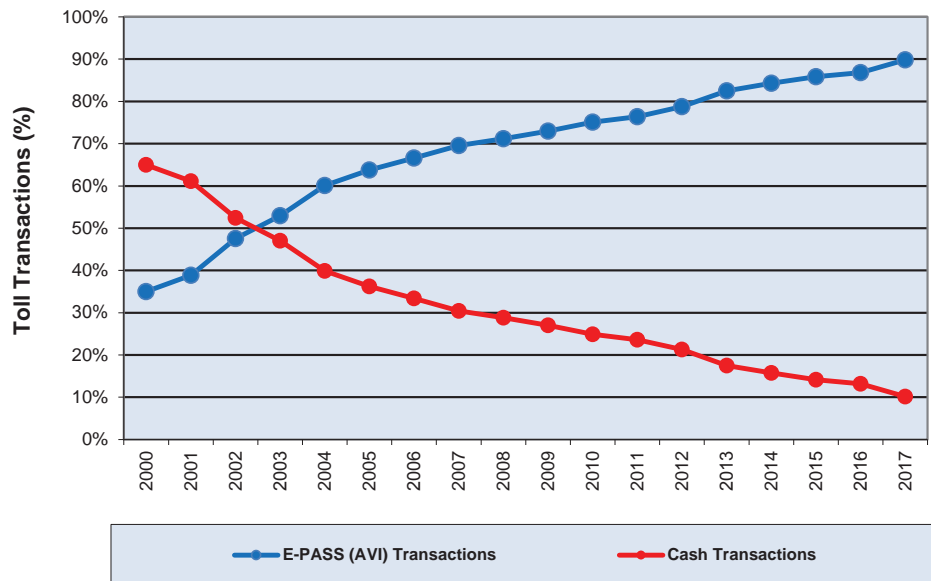

Year	Yearly Revenue Transaction		% Violations ⁽²⁾ (Percent of Total Transactions)
	% E-PASS (AVI) Transactions	% Cash Transactions	
2000	35.0%	65.0%	4.8%
2001	38.8%	61.2%	3.8%
2002	47.5%	52.5%	2.7%
2003	53.0%	47.0%	2.4%
2004	60.1%	39.9%	2.7%
2005	63.8%	36.2%	3.1%
2006	66.6%	33.4%	3.0%
2007	69.6%	30.4%	2.6%
2008	71.2%	28.8%	2.6%
2009	73.0%	27.0%	2.8%
2010	75.1%	24.9%	2.7%
2011	76.4%	23.6%	2.3%
2012	78.7%	21.3%	2.5%
2013	82.5%	17.5%	3.0%
2014	84.3%	15.7%	3.7%
2015	85.8%	14.2%	4.6%
2016	86.8%	13.2%	5.3%
2017	89.8%	10.2%	6.6%

1. All plazas had tolls suspended from 9/5/17 until 9/21/17 due to Hurricane Irma

2. Calculated as percent of Total Transactions, which is equal to Revenue Transactions plus Violations

Coral Hills Mainline Toll Facility (Apopka Expressway)



2017 Traffic Data and Statistics Manual
CENTRAL FLORIDA EXPRESSWAY AUTHORITY

OSCEOLA

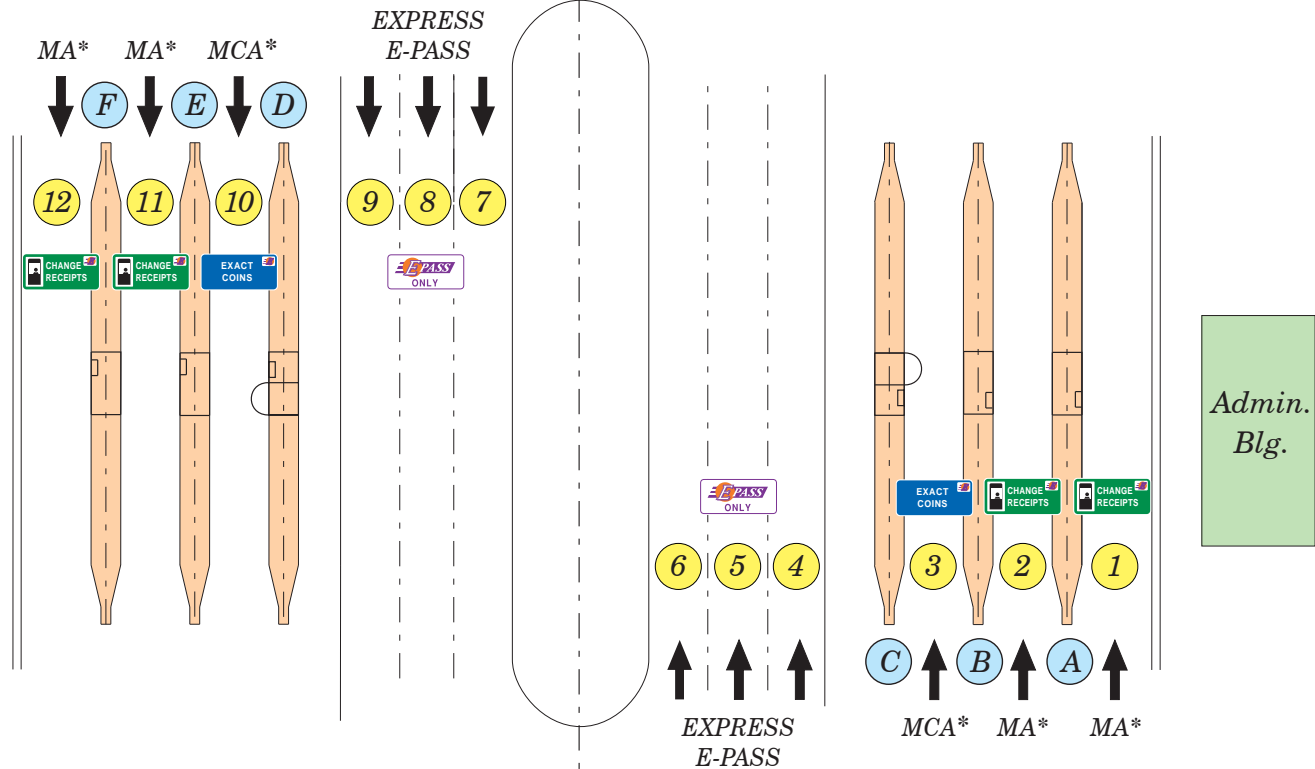

HISTORIC TRAFFIC - A.A.W.T.

2009	10,500
2010	13,025
2011	13,820
2012	16,320 (Toll Increase July 2012)
2013	20,870
2014	24,120
2015	29,100
2016	33,900
2017	36,930

TOLL RATE STRUCTURE **

	<u>E-PASS</u>	<u>CASH</u>
2 Axles	\$ 1.09	\$ 1.25
3 Axles	\$ 1.64	\$ 1.75
4 Axles	\$ 2.18	\$ 2.25
5 Axles or more	\$ 2.73	\$ 2.75

LANES OF EQUIPMENT

- 4 Manned Booths with E-PASS (MA)
- 2 Booths with ACM's and E-PASS
- 6 Express E-PASS (E-PASS only)
- * Changeable Message Sign

LEGEND

- ① Lane Number
- Ⓐ Island Designation

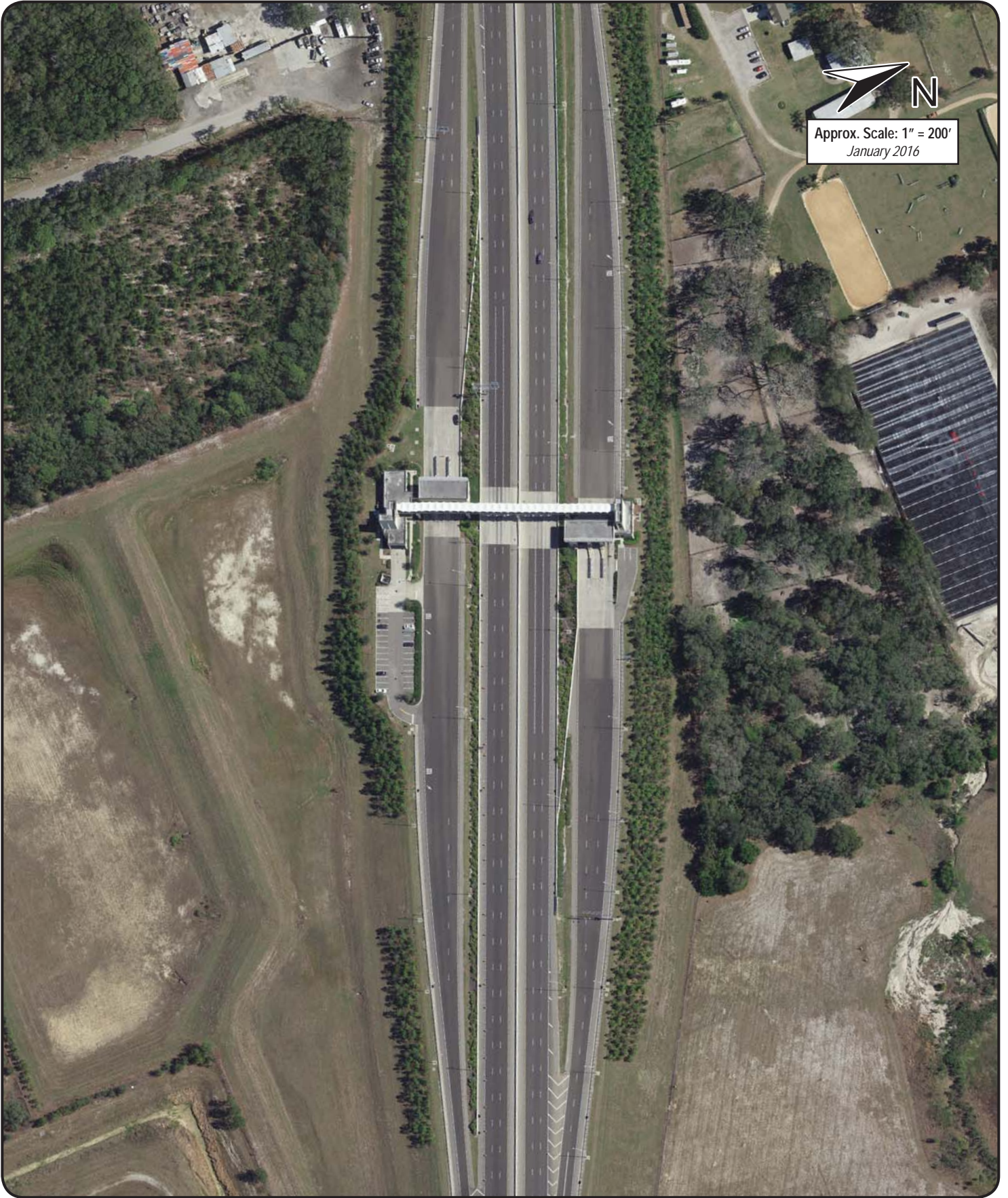

 N
Approx. Scale: 1" = 200'
January 2016

Coral Hills Mainline Toll Facility

SR 414 - Apopka Expressway

Fiscal Year 2017 Monthly Mainline & Ramp Toll Transactions and Revenue Summary

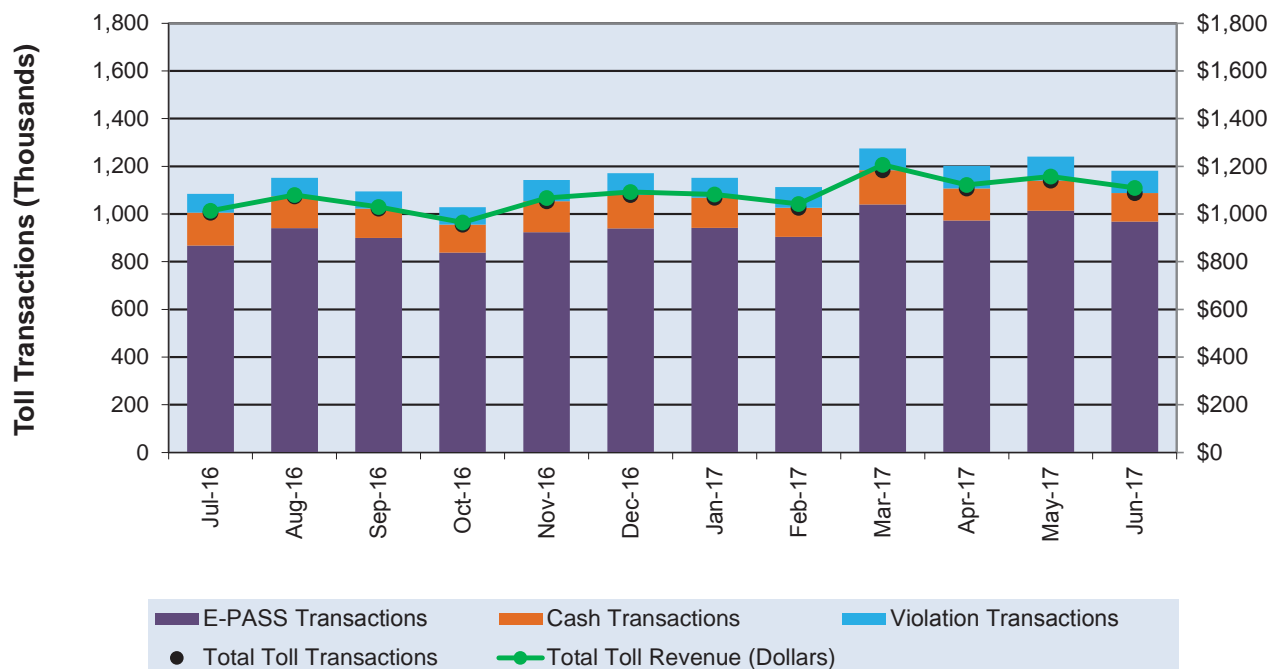

Month	FY 17 MONTHLY MAINLINE & RAMP TOLL TRANSACTIONS					Total Toll Revenue
	E-PASS	Cash	Total Revenue	Violations	Total	
July-16	868,187	137,224	1,005,411	78,947	1,084,358	\$1,013,700
August-16	940,703	133,230	1,073,933	77,318	1,151,251	\$1,080,235
September-16	899,449	123,124	1,022,573	71,938	1,094,511	\$1,029,435
October-16	838,657	116,857	955,514	72,584	1,028,098	\$964,284
November-16	923,713	129,996	1,053,709	88,870	1,142,579	\$1,067,604
December-16	939,877	140,245	1,080,122	91,323	1,171,445	\$1,092,966
January-17	941,864	126,899	1,068,763	82,994	1,151,757	\$1,081,673
February-17	904,076	122,169	1,026,245	86,277	1,112,522	\$1,042,510
March-17	1,040,155	143,140	1,183,295	91,878	1,275,173	\$1,207,004
April-17	972,964	134,148	1,107,112	95,094	1,202,206	\$1,122,098
May-17	1,013,667	126,968	1,140,635	99,686	1,240,321	\$1,158,008
June-17	968,594	119,882	1,088,476	92,871	1,181,347	\$1,109,792
Yearly Totals	11,251,906	1,553,882	12,805,788	1,029,780	13,835,568	\$12,969,309

Note: Data includes ramp toll plazas that report to the Coral Hills Mainline Toll Plaza.

1. Cash transactions were calculated as the difference between total revenue traffic and E-PASS traffic
2. All plazas had tolls suspended in FY 17 due to Hurricane Matthew from 10/5/16 until early on 10/10/16



Coral Hills Mainline Toll Facility
SR 414 - Apopka Expressway
Typical Daily Expressway Traffic Volumes - April 2017

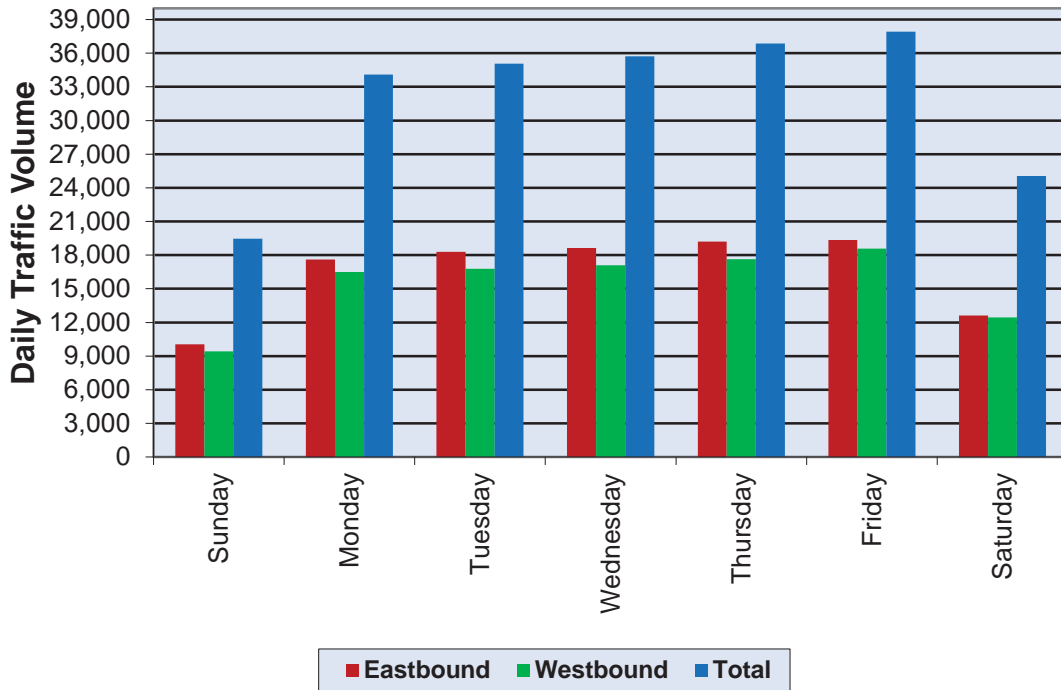

Day	Expressway Traffic Volumes		
	Eastbound	Westbound	Total
Sunday	10,050	9,420	19,470
Monday	17,600	16,500	34,100
Tuesday	18,290	16,780	35,070
Wednesday	18,630	17,100	35,730
Thursday	19,220	17,630	36,850
Friday	19,340	18,590	37,930
Saturday	12,620	12,440	25,060

Coral Hills Mainline Toll Facility
SR 414 - Apopka Expressway
Typical Average Five Day Hourly Traffic - April 2017

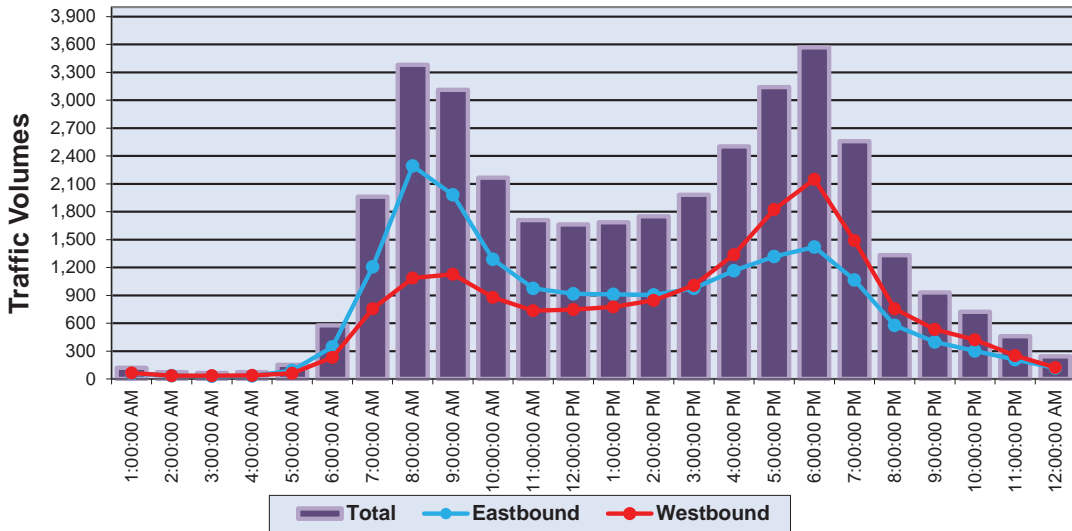

Hour Ending	Average Weekday Volumes		
	Eastbound	Westbound	Total
1:00 AM	58	64	122
2:00 AM	36	37	73
3:00 AM	30	35	65
4:00 AM	34	39	73
5:00 AM	91	63	154
6:00 AM	345	231	576
7:00 AM	1,206	756	1,962
8:00 AM	2,293	1,087	3,380
9:00 AM	1,983	1,127	3,110
10:00 AM	1,287	879	2,166
11:00 AM	975	736	1,711
12:00 PM	917	747	1,664

Hour Ending	Average Weekday Volumes		
	Eastbound	Westbound	Total
1:00 PM	912	775	1,687
2:00 PM	905	846	1,751
3:00 PM	974	1,008	1,982
4:00 PM	1,164	1,338	2,502
5:00 PM	1,317	1,823	3,140
6:00 PM	1,419	2,150	3,569
7:00 PM	1,067	1,490	2,557
8:00 PM	576	756	1,332
9:00 PM	398	532	930
10:00 PM	302	422	724
11:00 PM	208	253	461
12:00 AM	118	125	243

Total Eastbound	18,615
Total Westbound	17,319
Total Weekday	35,934

Coral Hills Mainline Toll Facility
SR 414 - Apopka Expressway
Typical Average Seven Day Hourly Traffic - April 2017

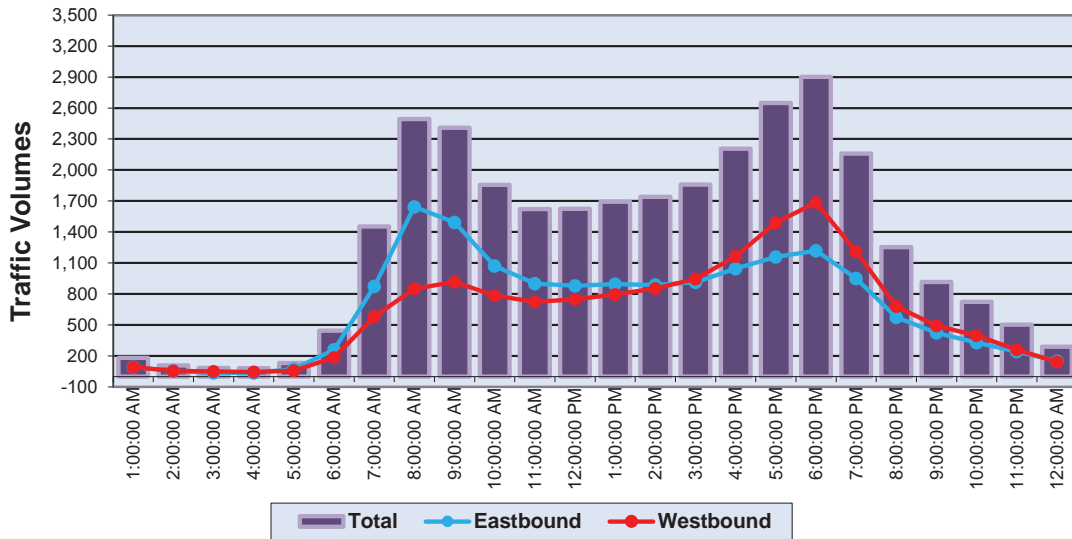

Hour Ending	Average Weekday Volumes		
	Eastbound	Westbound	Total
1:00 AM	91	91	182
2:00 AM	54	53	107
3:00 AM	36	48	84
4:00 AM	36	45	81
5:00 AM	73	57	131
6:00 AM	261	183	444
7:00 AM	873	581	1,454
8:00 AM	1,643	850	2,493
9:00 AM	1,493	917	2,409
10:00 AM	1,071	785	1,856
11:00 AM	899	722	1,621
12:00 PM	878	747	1,624

Hour Ending	Average Weekday Volumes		
	Eastbound	Westbound	Total
1:00 PM	896	796	1,692
2:00 PM	887	852	1,739
3:00 PM	913	946	1,859
4:00 PM	1,044	1,163	2,207
5:00 PM	1,159	1,491	2,650
6:00 PM	1,218	1,685	2,903
7:00 PM	950	1,210	2,159
8:00 PM	573	679	1,253
9:00 PM	423	492	915
10:00 PM	328	396	724
11:00 PM	242	259	502
12:00 AM	149	141	290

Total Eastbound	16,190
Total Westbound	15,188
Total Weekday	31,378

Coral Hills Mainline Toll Facility

Toll Facility Peak Hour Characteristic Summary Typical Average Weekday (Monday through Friday) - April 2017

Average Weekday Traffic Summary (unadjusted)

Average Weekday Total Traffic	35,934
Eastbound Directional Traffic	18,615
Westbound Directional Traffic	17,319

Morning Peak Hour Summary (7:00 a.m. to 8:00 a.m.)

Eastbound Directional Traffic	2,293
Westbound Directional Traffic	1,087
Total AM Peak Hour Traffic	3,380

AM Peak Hour Factor ("K") = Total Peak Hour Traffic / Average Weekday Total Traffic

AM Peak Hour Factor ("K_{am}") **9.41%**

AM Peak Hour Directional Factor ("D") = Peak Directional Traffic / Total Peak Hour Traffic

AM Peak Hour Directional Factor ("D_{am}") **67.84%**

Evening Peak Hour Summary (5:00 p.m. to 6:00 p.m.)

Eastbound Directional Traffic	1,419
Westbound Directional Traffic	2,150
Total PM Peak Hour Traffic	3,569

PM Peak Hour Factor ("K") = Total Peak Hour Traffic / Average Weekday Total Traffic

PM Peak Hour Factor ("K_{pm}") **9.93%**

PM Peak Hour Directional Factor ("D") = Peak Directional Traffic / Total Peak Hour Traffic

PM Peak Hour Directional Factor ("D_{pm}") **60.24%**

Coral Hills Mainline Toll Facility

Toll Transaction Summary

Typical Average Weekday (Monday through Friday) - April 2017

Average Weekday Summary

Direction of Travel	E-PASS (AVI)		ACM (Coin)		Manual (Cash)		Total	
	Volume	% Usage	Volume	% Usage	Volume	% Usage	Traffic	% Usage
Eastbound	17,060	92%	300	2%	1,255	7%	18,615	100%
Westbound	15,271	88%	819	5%	1,229	7%	17,319	100%

Morning Peak Hour Summary (7:00 a.m. to 8:00 a.m.)

Direction of Travel	E-PASS (AVI)		ACM (Coin)		Manual (Cash)		Total	
	Volume	% Usage	Volume	% Usage	Volume	% Usage	Traffic	% Usage
Eastbound	2,171	95%	25	1%	97	4%	2,293	100%
Westbound	946	87%	72	7%	69	6%	1,087	100%

Evening Peak Hour Summary (5:00 p.m. to 6:00 p.m.)

Direction of Travel	E-PASS (AVI)		ACM (Coin)		Manual (Cash)		Total	
	Volume	% Usage	Volume	% Usage	Volume	% Usage	Traffic	% Usage
Eastbound	1,300	92%	23	2%	96	7%	1,419	100%
Westbound	1,999	93%	30	1%	121	6%	2,150	100%

Coral Hills Mainline Toll Facility
SR 414 - Apopka Expressway
Historical & Existing Total Revenue Transactions Statistics

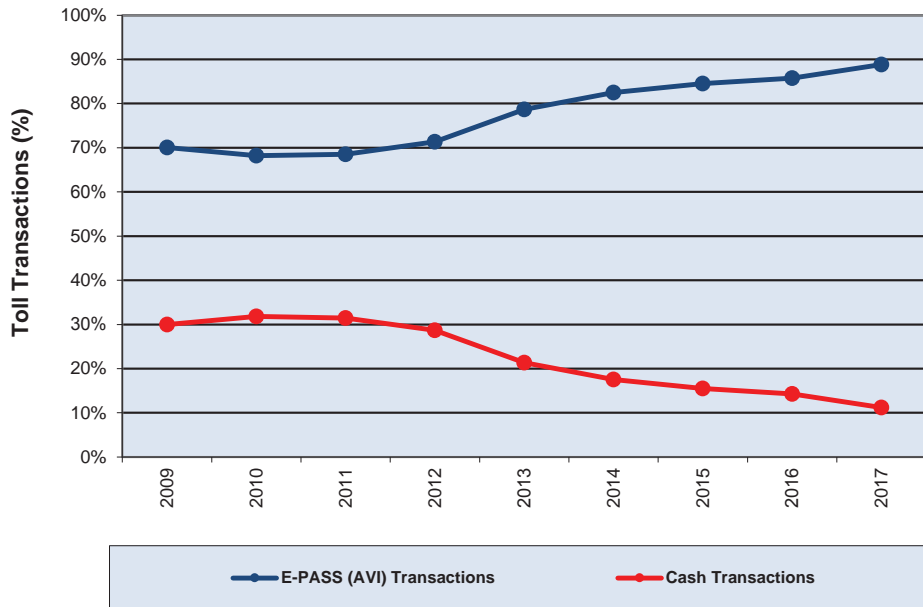

Year	Yearly Revenue Transaction		% Violations ⁽²⁾ (Percent of Total Transactions)
	% E-PASS (AVI) Transactions	% Cash Transactions	
2000	Not Open to Traffic		
2001	Not Open to Traffic		
2002	Not Open to Traffic		
2003	Not Open to Traffic		
2004	Not Open to Traffic		
2005	Not Open to Traffic		
2006	Not Open to Traffic		
2007	Not Open to Traffic		
2008	Not Open to Traffic		
2009	70.1%	29.9%	2.9%
2010	68.2%	31.8%	2.5%
2011	68.5%	31.5%	2.7%
2012	71.3%	28.7%	2.9%
2013	78.6%	21.4%	3.4%
2014	82.5%	17.5%	4.2%
2015	84.5%	15.5%	5.0%
2016	85.7%	14.3%	5.8%
2017	88.8%	11.2%	8.4%

1. All plazas had tolls suspended from 9/5/17 until 9/21/17 due to Hurricane Irma

2. Calculated as percent of Total Transactions, which is equal to Revenue Transactions plus Violations

Goldenrod Mainline Toll Facility (Goldenrod Road Extension)

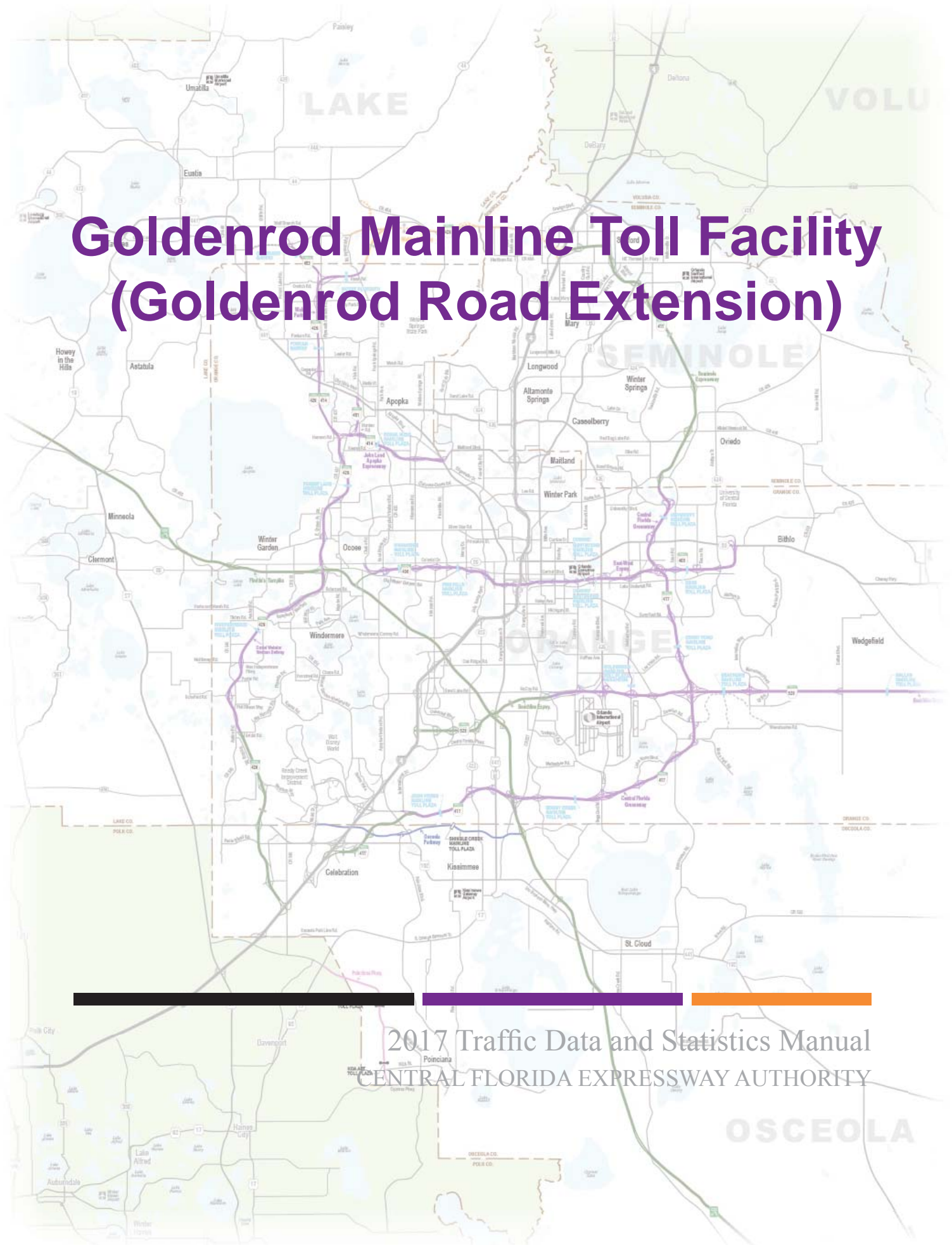

2017 Traffic Data and Statistics Manual
CENTRAL FLORIDA EXPRESSWAY AUTHORITY

OSCEOLA

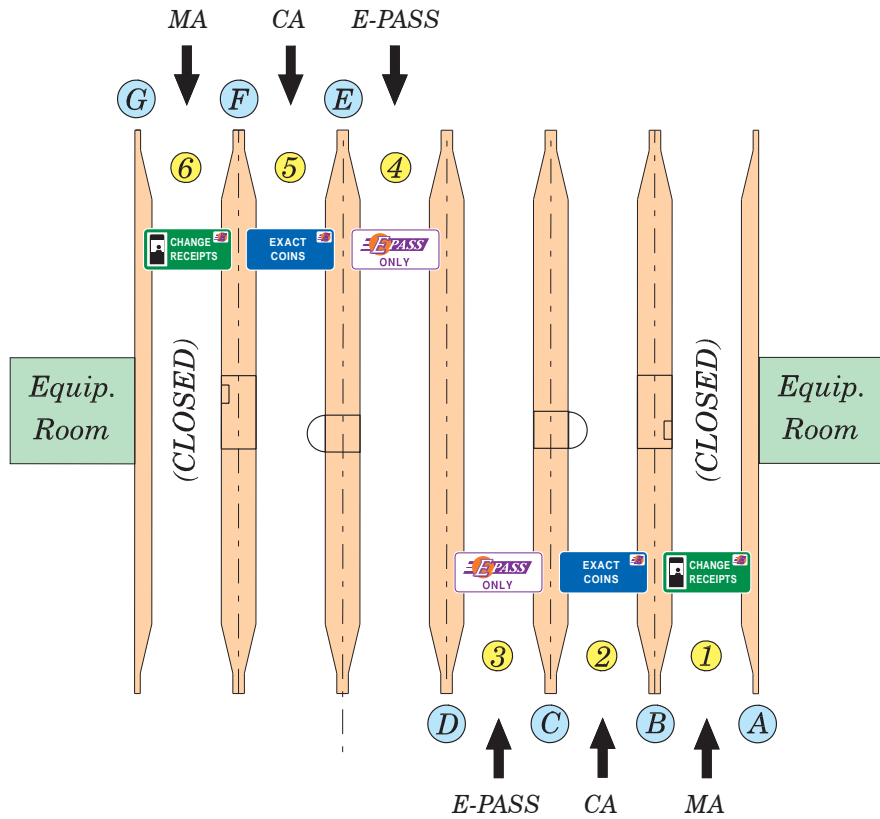

HISTORIC TRAFFIC - A.A.W.T.

2016	12,000
2017	13,510

<u>TOLL RATE STRUCTURE **</u>		
	<u>E-PASS</u>	<u>CASH</u>
All Vehicles	\$ 0.50	\$ 0.50

LANES OF EQUIPMENT

- 2 Automatic Coin Machines with E-PASS (CA)
- 2 Dedicated E-PASS (E-PASS only)

LEGEND

- ① Lane Number
- Ⓐ Island Designation

Note: All Changeable Message Signs (CMS) can display three messages: EXACT COINS, CHANGE RECEIPTS, E-PASS ONLY



Approx. Scale: 1" = 200'
January 2016

Goldenrod Mainline Toll Facility Goldenrod Road Extension

Fiscal Year 2017 Monthly Mainline & Ramp Toll Transactions and Revenue Summary

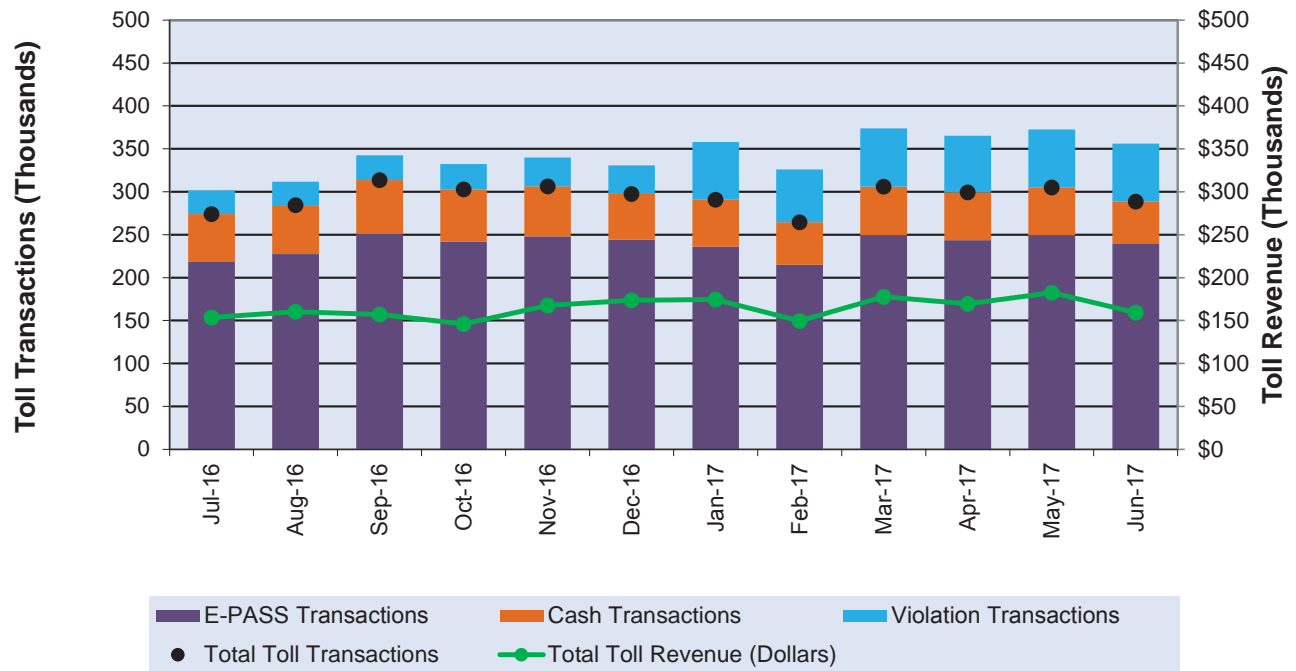

Month	FY 17 MONTHLY MAINLINE & RAMP TOLL TRANSACTIONS					Total Toll Revenue
	E-PASS	Cash	Total Revenue	Violations	Total	
July-16	218,105	55,910	274,015	27,404	301,419	\$153,541
August-16	227,369	57,239	284,608	27,136	311,744	\$160,359
September-16	251,183	62,346	313,529	28,837	342,366	\$157,140
October-16	242,033	60,674	302,707	29,540	332,247	\$146,055
November-16	248,110	58,218	306,328	33,441	339,769	\$167,494
December-16	244,279	53,016	297,295	33,580	330,875	\$173,671
January-17	235,883	54,950	290,833	67,084	357,917	\$174,605
February-17	215,066	49,530	264,596	61,360	325,956	\$149,569
March-17	249,447	56,451	305,898	67,868	373,766	\$177,631
April-17	243,646	55,728	299,374	65,857	365,231	\$169,489
May-17	249,188	55,987	305,175	67,296	372,471	\$182,518
June-17	239,189	49,438	288,627	67,371	355,998	\$159,196
Yearly Totals	2,863,498	669,487	3,532,985	576,774	4,109,759	\$1,971,268

Note: Transaction Data obtained from CFX Monthly Transaction Report from CFX.

1. Cash transactions were calculated as the difference between total revenue traffic and E-PASS traffic
2. All plazas had tolls suspended in FY 17 due to Hurricane Matthew from 10/5/16 until early on 10/10/16



Goldenrod Mainline Toll Facility
Goldenrod Road Extension
 Typical Daily Traffic Volumes - April 2017

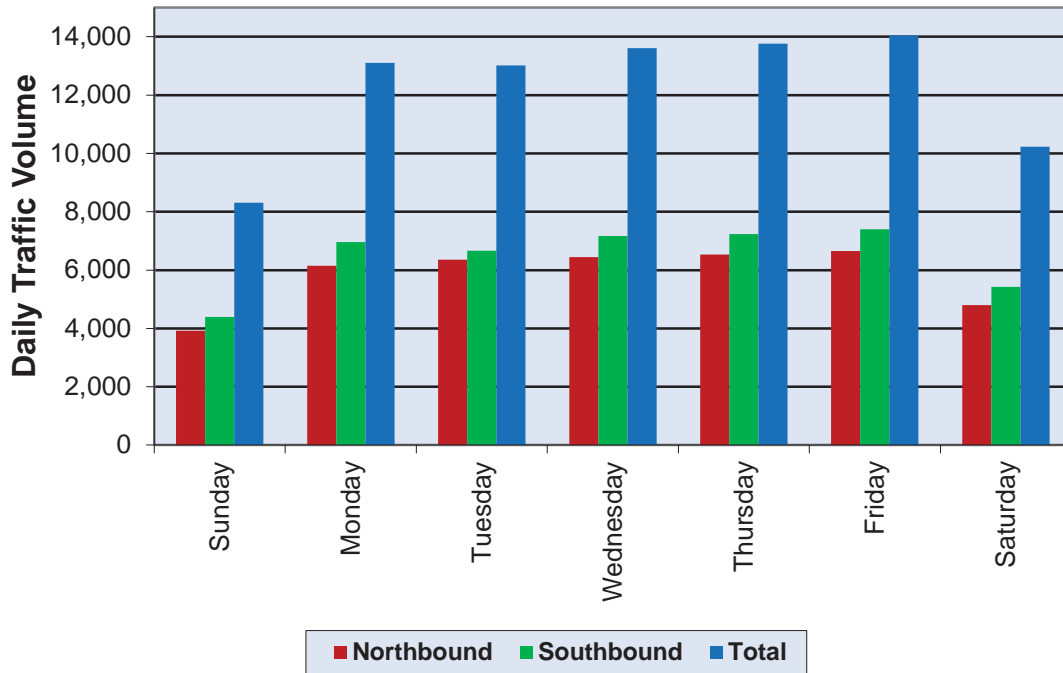

Day	Expressway Traffic Volumes		
	Northbound	Southbound	Total
Sunday	3,920	4,390	8,310
Monday	6,150	6,960	13,110
Tuesday	6,360	6,660	13,020
Wednesday	6,440	7,170	13,610
Thursday	6,530	7,230	13,760
Friday	6,650	7,400	14,050
Saturday	4,800	5,430	10,230

Goldenrod Mainline Toll Facility Goldenrod Extension Average Five Day Hourly Traffic - April 2017

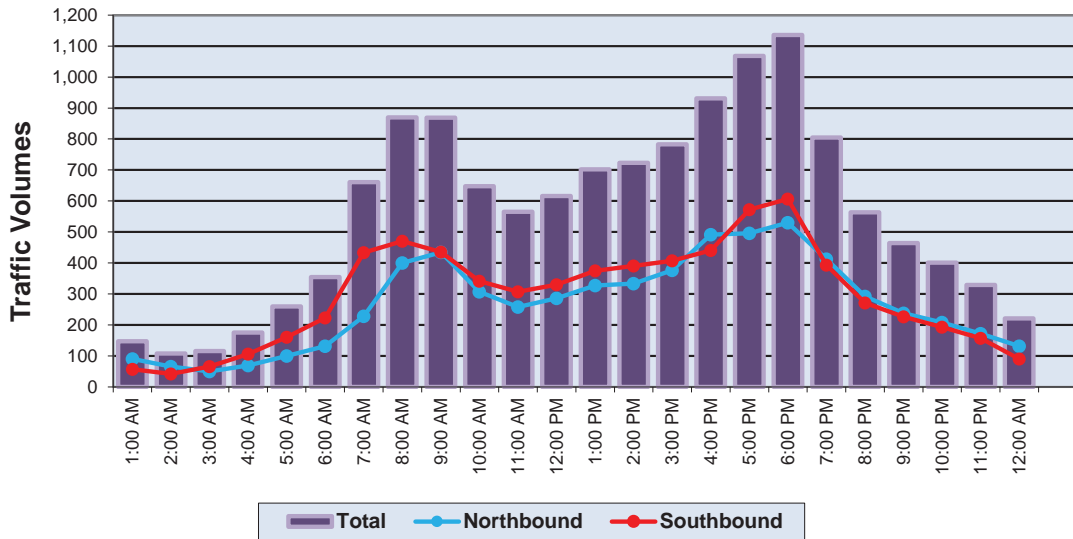

Hour Ending	Average Weekday Volumes		
	Northbound	Southbound	Total
1:00 AM	90	57	147
2:00 AM	66	42	108
3:00 AM	50	66	116
4:00 AM	69	106	175
5:00 AM	100	160	260
6:00 AM	131	223	354
7:00 AM	228	433	661
8:00 AM	400	470	870
9:00 AM	434	435	869
10:00 AM	307	341	648
11:00 AM	258	307	565
12:00 PM	286	330	616

Hour Ending	Average Weekday Volumes		
	Northbound	Southbound	Total
1:00 PM	327	375	702
2:00 PM	333	390	723
3:00 PM	376	407	783
4:00 PM	491	440	931
5:00 PM	496	572	1,068
6:00 PM	530	606	1,136
7:00 PM	412	393	805
8:00 PM	292	271	563
9:00 PM	238	226	464
10:00 PM	208	193	401
11:00 PM	172	157	329
12:00 AM	131	90	221

Total Northbound	6,425
Total Southbound	7,090
Total Weekday	13,515

Goldenrod Mainline Toll Facility Goldenrod Road Extension Average Seven Day Hourly Traffic - April 2017

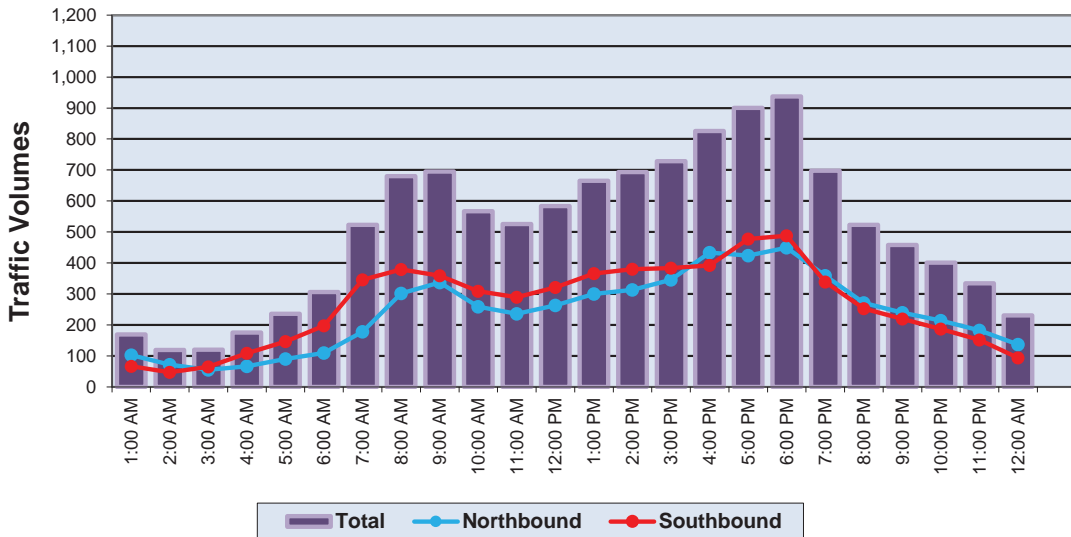

Hour Ending	Average Weekday Volumes		
	Northbound	Southbound	Total
1:00 AM	103	66	169
2:00 AM	72	47	119
3:00 AM	55	65	120
4:00 AM	66	109	175
5:00 AM	90	146	236
6:00 AM	110	197	307
7:00 AM	178	345	523
8:00 AM	302	379	680
9:00 AM	337	358	695
10:00 AM	258	308	567
11:00 AM	236	289	525
12:00 PM	263	321	584

Hour Ending	Average Weekday Volumes		
	Northbound	Southbound	Total
1:00 PM	300	366	665
2:00 PM	313	380	693
3:00 PM	345	383	728
4:00 PM	433	392	826
5:00 PM	424	477	901
6:00 PM	449	488	937
7:00 PM	359	339	698
8:00 PM	271	252	523
9:00 PM	239	219	458
10:00 PM	214	187	401
11:00 PM	183	151	334
12:00 AM	137	94	231

Total Northbound	5,736
Total Southbound	6,359
Total Weekday	12,095

Goldenrod Mainline Toll Facility

Toll Facility Peak Hour Characteristic Summary Typical Average Weekday (Monday through Friday) - April 2017

Average Weekday Traffic Summary (unadjusted)

Average Weekday Total Traffic	13,515
Northbound Directional Traffic	6,425
Southbound Directional Traffic	7,090

Morning Peak Hour Summary (7:00 a.m. to 8:00 a.m.)

Northbound Directional Traffic	400
Southbound Directional Traffic	470
Total AM Peak Hour Traffic	870

AM Peak Hour Factor ("K") = Total Peak Hour Traffic / Average Weekday Total Traffic

AM Peak Hour Factor ("K_{am}") **6.44%**

AM Peak Hour Directional Factor ("D") = Peak Directional Traffic / Total Peak Hour Traffic

AM Peak Hour Directional Factor ("D_{am}") **54.02%**

Evening Peak Hour Summary (5:00 p.m. to 6:00 p.m.)

Northbound Directional Traffic	530
Southbound Directional Traffic	606
Total PM Peak Hour Traffic	1,136

PM Peak Hour Factor ("K") = Total Peak Hour Traffic / Average Weekday Total Traffic

PM Peak Hour Factor ("K_{pm}") **8.41%**

PM Peak Hour Directional Factor ("D") = Peak Directional Traffic / Total Peak Hour Traffic

PM Peak Hour Directional Factor ("D_{pm}") **53.35%**

Goldenrod Mainline Toll Facility

Toll Transaction Summary

Typical Average Weekday (Monday through Friday) - April 2017

Average Weekday Summary

Direction of Travel	E-PASS (AVI)		ACM (Coin)		Manual (Cash)		Total	
	Volume	% Usage	Volume	% Usage	Volume	% Usage	Traffic	% Usage
Northbound	4,978	77%	1,447	23%	0	0%	6,425	100%
Southbound	5,151	73%	1,939	27%	0	0%	7,090	100%

Morning Peak Hour Summary (7:00 a.m. to 8:00 a.m.)

Direction of Travel	E-PASS (AVI)		ACM (Coin)		Manual (Cash)		Total	
	Volume	% Usage	Volume	% Usage	Volume	% Usage	Traffic	% Usage
Northbound	332	83%	68	17%	0	0%	400	100%
Southbound	342	73%	128	27%	0	0%	470	100%

Evening Peak Hour Summary (5:00 p.m. to 6:00 p.m.)

Direction of Travel	E-PASS (AVI)		ACM (Coin)		Manual (Cash)		Total	
	Volume	% Usage	Volume	% Usage	Volume	% Usage	Traffic	% Usage
Northbound	413	78%	117	22%	0	0%	530	100%
Southbound	491	81%	115	19%	0	0%	606	100%

Goldenrod Mainline Toll Facility
Goldenrod Road Extension
Historical & Existing Total Revenue Transactions Statistics

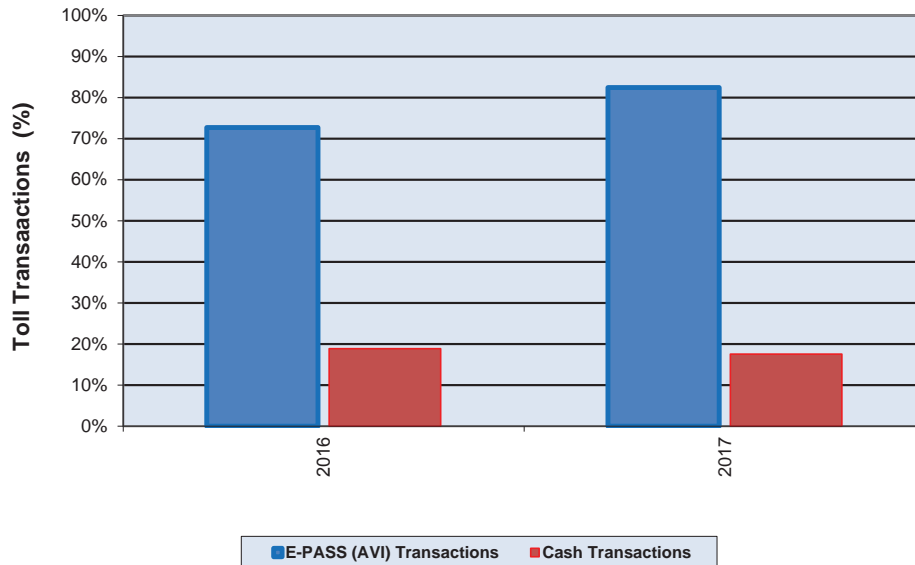

Year	Yearly Revenue Transaction		% Violations ⁽²⁾ (Percent of Total Transactions)
	% E-PASS (AVI) Transactions	% Cash Transactions	
2016	72.7%	18.9%	8.4%
2017	82.5%	17.5%	19.7%

1. All plazas had tolls suspended from 9/5/17 until 9/21/17 due to Hurricane Irma

2. Calculated as percent of Total Transactions, which is equal to Revenue Transactions plus Violations

Ponkan Toll Gantry Facility (Wekiva Parkway)



2017 Traffic Data and Statistics Manual
CENTRAL FLORIDA EXPRESSWAY AUTHORITY

OSCEOLA

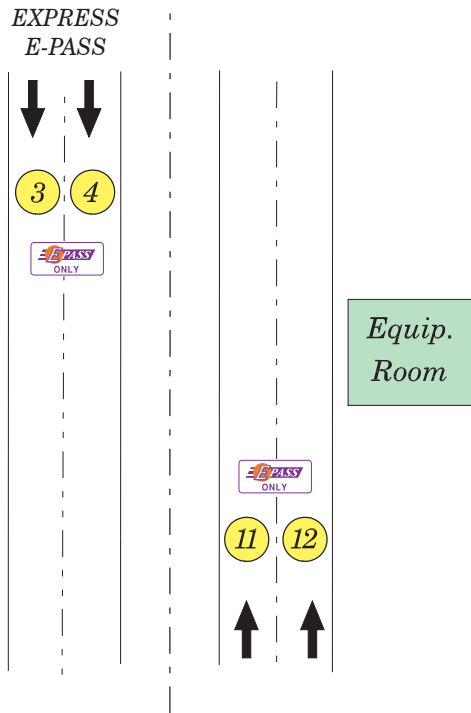

HISTORIC TRAFFIC - A.A.W.T.
2017 9,560*

<u>TOLL RATE STRUCTURE **</u>		
	<u>E-PASS</u>	<u>PBP</u>
2 Axles	\$.80	\$ 1.39
3 Axles	\$ 1.20	\$ 1.79
4 Axles	\$ 1.60	\$ 2.19
5 Axles or more	\$ 2.00	\$ 2.59

LANES OF EQUIPMENT

4 Dedicated E-PASS (E-PASS and PBP)
* Opened to traffic July 28, 2017

LEGEND

① Lane Number



Not to Scale
Orange County Property
Appraiser, 2018

Ponkan Toll Gantry SR 429 - Wekiva Parkway

Fiscal Year 2017 Monthly Mainline & Ramp Toll Transactions and Revenue Summary

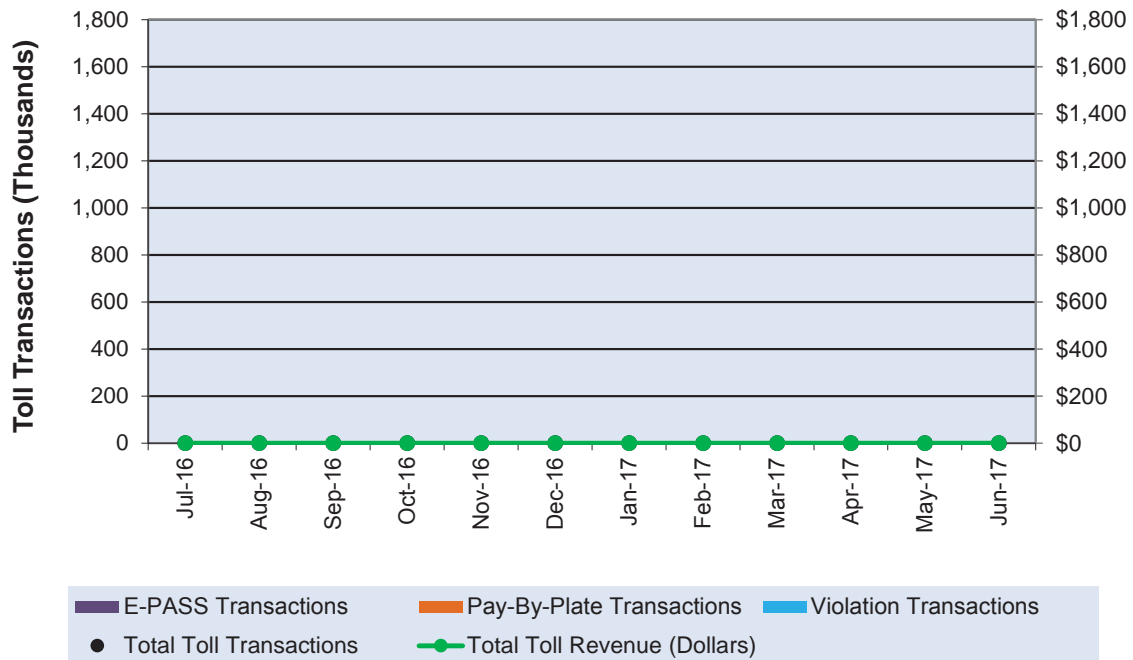

Month	FY 17 MONTHLY MAINLINE & RAMP TOLL TRANSACTIONS				Total Toll Revenue
	E-PASS	Cash	Violations	Total	
July-16	No Data	No Data	No Data	No Data	No Data
August-16	No Data	No Data	No Data	No Data	No Data
September-16	No Data	No Data	No Data	No Data	No Data
October-16	No Data	No Data	No Data	No Data	No Data
November-16	No Data	No Data	No Data	No Data	No Data
December-16	No Data	No Data	No Data	No Data	No Data
January-17	No Data	No Data	No Data	No Data	No Data
February-17	No Data	No Data	No Data	No Data	No Data
March-17	No Data	No Data	No Data	No Data	No Data
April-17	No Data	No Data	No Data	No Data	No Data
May-17	No Data	No Data	No Data	No Data	No Data
June-17	No Data	No Data	No Data	No Data	No Data
Yearly Totals	0	0	0	0	\$0

Note:

1. Pay-By-Plate transactions were calculated as the difference between total revenue traffic and E-PASS traffic
2. Ponkan Toll Gantry opened to traffic on July 28, 2017

Ponkan Toll Gantry

SR 429 - Wekiva Parkway

Typical Daily Expressway Traffic Volumes - April 2017

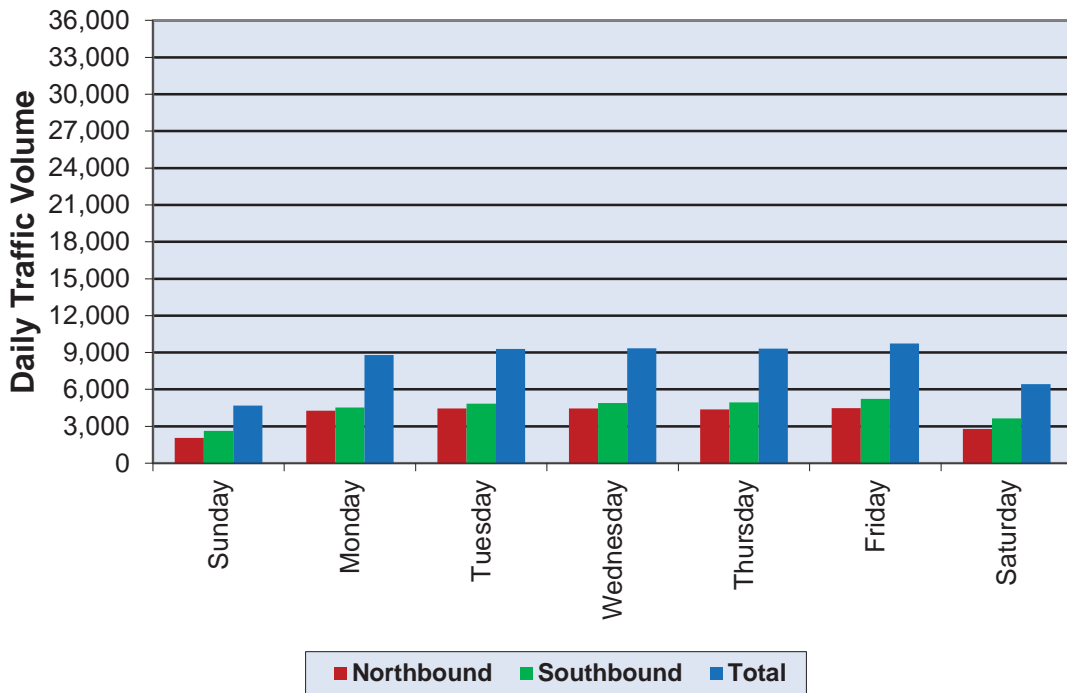

Day	Expressway Traffic Volumes		
	Northbound	Southbound	Total
Sunday	2,014	2,571	4,585
Monday	4,181	4,449	8,630
Tuesday	4,367	4,733	9,099
Wednesday	4,356	4,789	9,145
Thursday	4,275	4,841	9,116
Friday	4,394	5,155	9,548
Saturday	2,733	3,594	6,327

Ponkan Toll Gantry
SR 429 - Wekiva Parkway
 Typical Average Five Day Hourly Traffic - April 2017

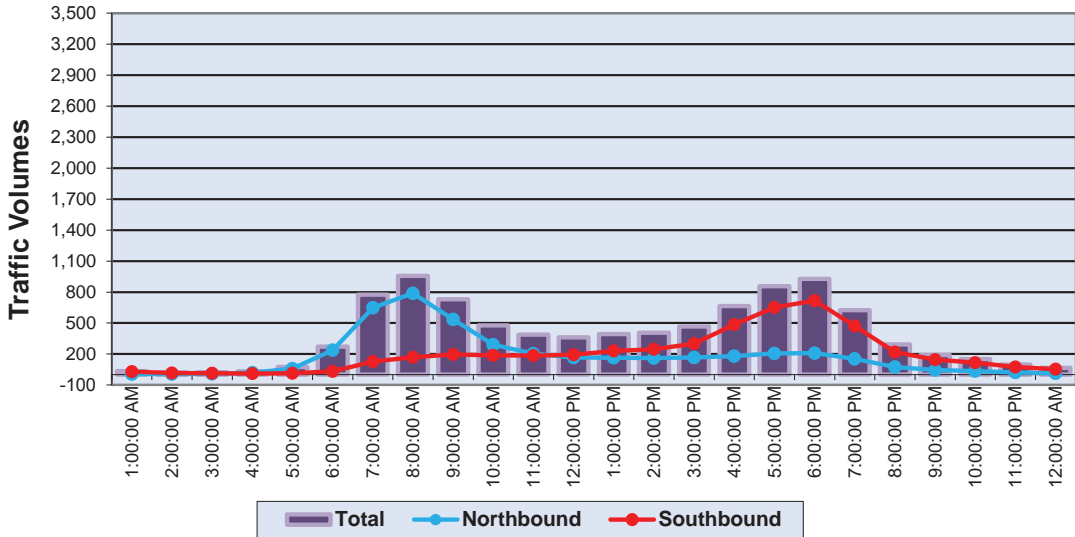

Hour Ending	Average Weekday Volumes		
	Northbound	Southbound	Total
1:00 AM	7	22	28
2:00 AM	6	12	18
3:00 AM	10	9	18
4:00 AM	20	8	28
5:00 AM	58	10	68
6:00 AM	233	24	257
7:00 AM	634	98	732
8:00 AM	773	133	906
9:00 AM	524	155	680
10:00 AM	284	149	433
11:00 AM	200	145	346
12:00 PM	165	154	319

Hour Ending	Average Weekday Volumes		
	Northbound	Southbound	Total
1:00 PM	161	184	345
2:00 PM	158	195	354
3:00 PM	162	237	399
4:00 PM	177	387	564
5:00 PM	202	510	712
6:00 PM	206	561	766
7:00 PM	151	367	518
8:00 PM	73	171	244
9:00 PM	44	113	157
10:00 PM	34	91	124
11:00 PM	22	58	80
12:00 AM	13	42	55

Total Northbound	4,314
Total Southbound	3,835
Total Weekday	8,150

Ponkan Toll Gantry
SR 429 - Wekiva Parkway
 Typical Average Seven Day Hourly Traffic - April 2017

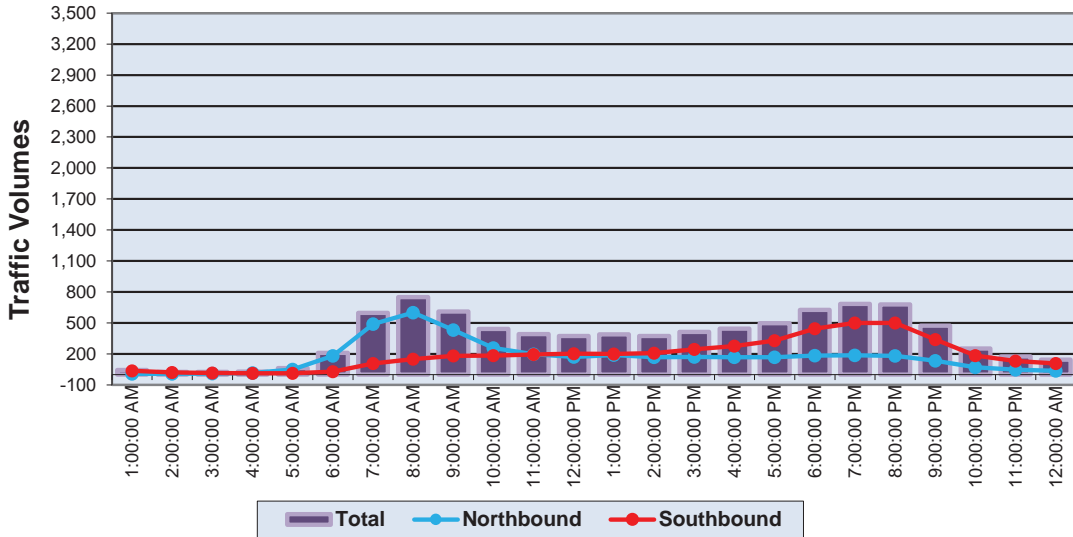

Hour Ending	Average Weekday Volumes		
	Northbound	Southbound	Total
1:00 AM	8	35	42
2:00 AM	7	19	25
3:00 AM	9	13	22
4:00 AM	16	10	26
5:00 AM	47	13	59
6:00 AM	178	26	204
7:00 AM	480	105	585
8:00 AM	588	147	735
9:00 AM	422	178	600
10:00 AM	253	183	435
11:00 AM	193	192	385
12:00 PM	167	201	369

Hour Ending	Average Weekday Volumes		
	Northbound	Southbound	Total
1:00 PM	184	198	382
2:00 PM	164	205	370
3:00 PM	167	240	408
4:00 PM	165	273	437
5:00 PM	166	324	490
6:00 PM	179	436	615
7:00 PM	183	490	673
8:00 PM	176	489	665
9:00 PM	132	333	465
10:00 PM	69	179	247
11:00 PM	44	127	171
12:00 AM	36	106	142

Total Northbound	4,031
Total Southbound	4,522
Total Weekday	8,553

Ponkan Toll Gantry

Toll Facility Peak Hour Characteristic Summary Typical Average Weekday (Monday through Friday) - April 2017

Average Weekday Traffic Summary (unadjusted)

Average Weekday Total Traffic	8,150
Northbound Directional Traffic	4,314
Southbound Directional Traffic	3,835

Morning Peak Hour Summary (7:00 a.m. to 8:00 a.m.)

Northbound Directional Traffic	773
Southbound Directional Traffic	133
Total AM Peak Hour Traffic	906

AM Peak Hour Factor ("K") = Total Peak Hour Traffic / Average Weekday Total Traffic

AM Peak Hour Factor ("K_{am}") 11.11%

AM Peak Hour Directional Factor ("D") = Peak Directional Traffic / Total Peak Hour Traffic

AM Peak Hour Directional Factor ("D_{am}") 85.31%

Evening Peak Hour Summary (5:00 p.m. to 6:00 p.m.)

Northbound Directional Traffic	206
Southbound Directional Traffic	561
Total PM Peak Hour Traffic	766

PM Peak Hour Factor ("K") = Total Peak Hour Traffic / Average Weekday Total Traffic

PM Peak Hour Factor ("K_{pm}") 9.40%

PM Peak Hour Directional Factor ("D") = Peak Directional Traffic / Total Peak Hour Traffic

PM Peak Hour Directional Factor ("D_{pm}") 73.14%

Ponkan Toll Gantry

Toll Transaction Summary

Typical Average Weekday (Monday through Friday) - April 2017

Average Weekday Summary

Direction of Travel	E-PASS (AVI)		ACM (Coin)		Manual (Cash)		Total	
	Volume	% Usage	Volume	% Usage	Volume	% Usage	Traffic	% Usage
Northbound	4,314	100%	0	0%	0	0%	4,314	100%
Southbound	3,835	100%	0	0%	0	0%	3,835	100%

Morning Peak Hour Summary (7:00 a.m. to 8:00 a.m.)

Direction of Travel	E-PASS (AVI)		ACM (Coin)		Manual (Cash)		Total	
	Volume	% Usage	Volume	% Usage	Volume	% Usage	Traffic	% Usage
Northbound	773	100%	0	0%	0	0%	773	100%
Southbound	133	100%	0	0%	0	0%	133	100%

Evening Peak Hour Summary (5:00 p.m. to 6:00 p.m.)

Direction of Travel	E-PASS (AVI)		ACM (Coin)		Manual (Cash)		Total	
	Volume	% Usage	Volume	% Usage	Volume	% Usage	Traffic	% Usage
Northbound	206	100%	0	0%	0	0%	206	100%
Southbound	561	100%	0	0%	0	0%	561	100%

Ponkan Toll Gantry
SR 429 - Wekiva Parkway
 Historical & Existing Toll Transactions Statistics

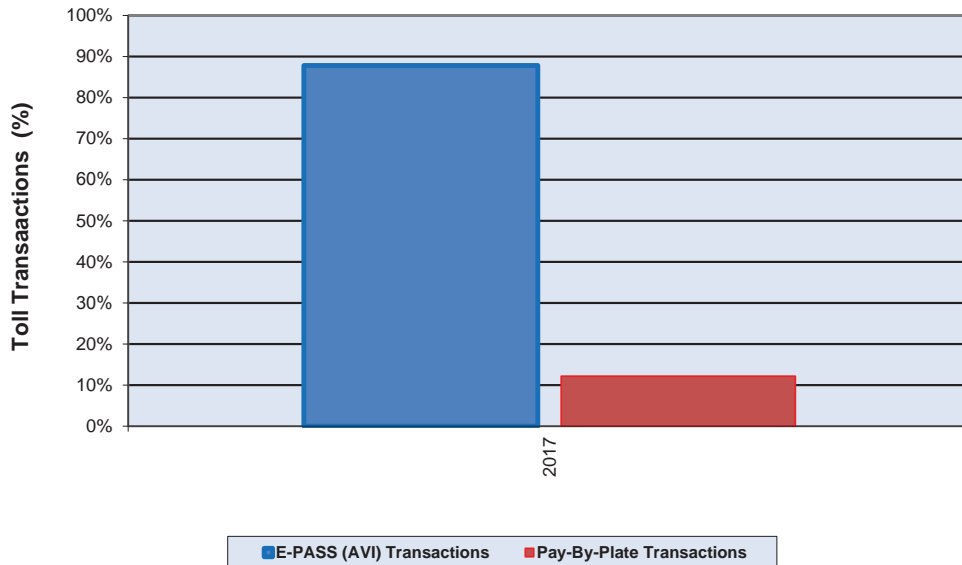

Year	Yearly Historical Toll Transaction Statistics	
	E-PASS (AVI) Transactions	Pay-By-Plate Transactions
2017	87.8%	12.2%

1. All plazas had tolls suspended from 9/5/17 until 9/21/17 due to Hurricane Irma
2. Ponkan Toll Gantry opened to traffic on July 28, 2017



Section IV: Interchanges

2017 Traffic Data and Statistics Manual
CENTRAL FLORIDA EXPRESSWAY AUTHORITY

East-West Expressway Interchanges



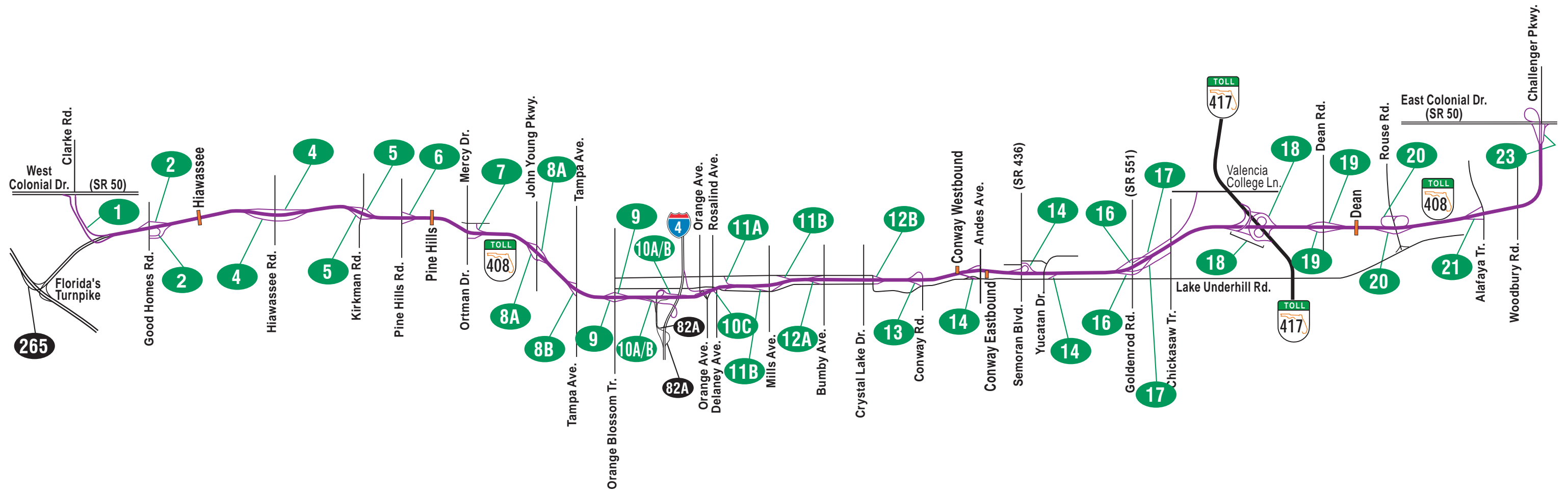

LEGEND

- Exit Number
- Existing SR 408
- Mainline Toll Plaza

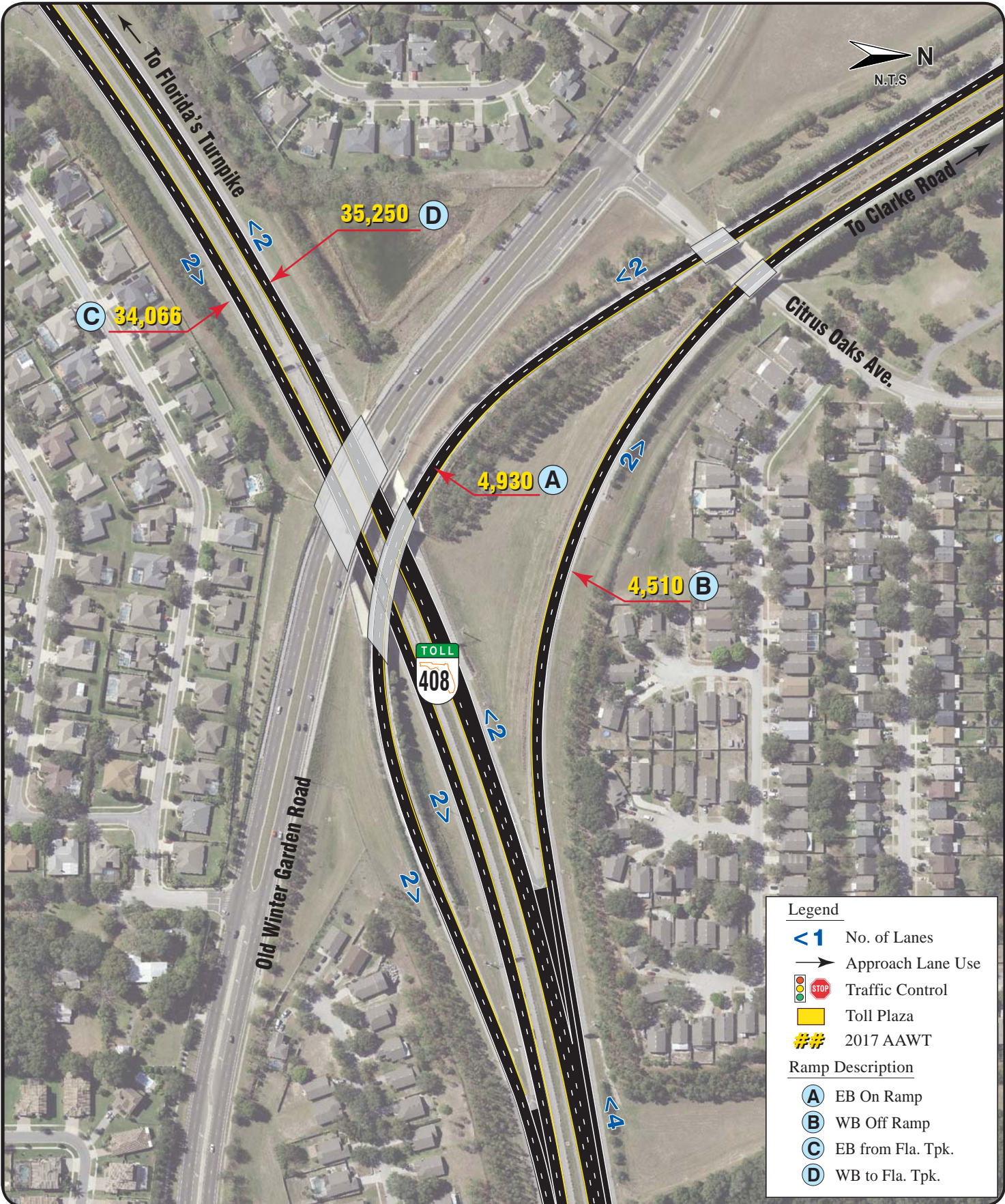

Legend

- <1> No. of Lanes
- Approach Lane Use
- Traffic Control
- Toll Plaza
- ## 2017 AAWT

Ramp Description

- A** EB On Ramp
- B** WB Off Ramp
- C** EB from Fla. Tpk.
- D** WB to Fla. Tpk.

E-PASS* CA* CA* E-PASS*

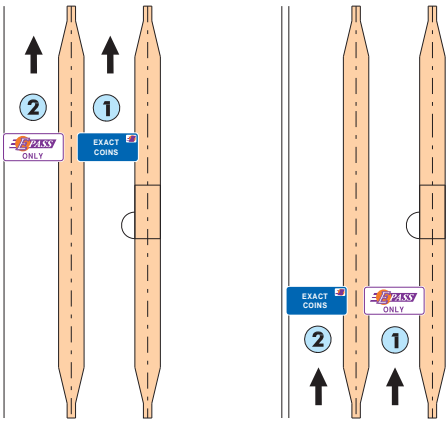

GOOD HOMES
OFF RAMP

GOOD HOMES
ON RAMP

Reports to Hiwassee Mainline Toll Plaza

Ramp Toll: E-PASS \$0.28 - CASH \$0.50

* Changeable Message Sign

Note: All Changeable Message Signs (CMS) can display three messages:
EXACT COINS, CHANGE RECEIPTS, E-PASS ONLY

Legend

- <1 No. of Lanes
- Approach Lane Use
- STOP Traffic Control
- Yellow Box Toll Plaza
- ## 2017 AAWT

Ramp Description

- (A) EB On Ramp
- (B) WB Off Ramp
- (C) EB Off Ramp
- (D) WB On Ramp

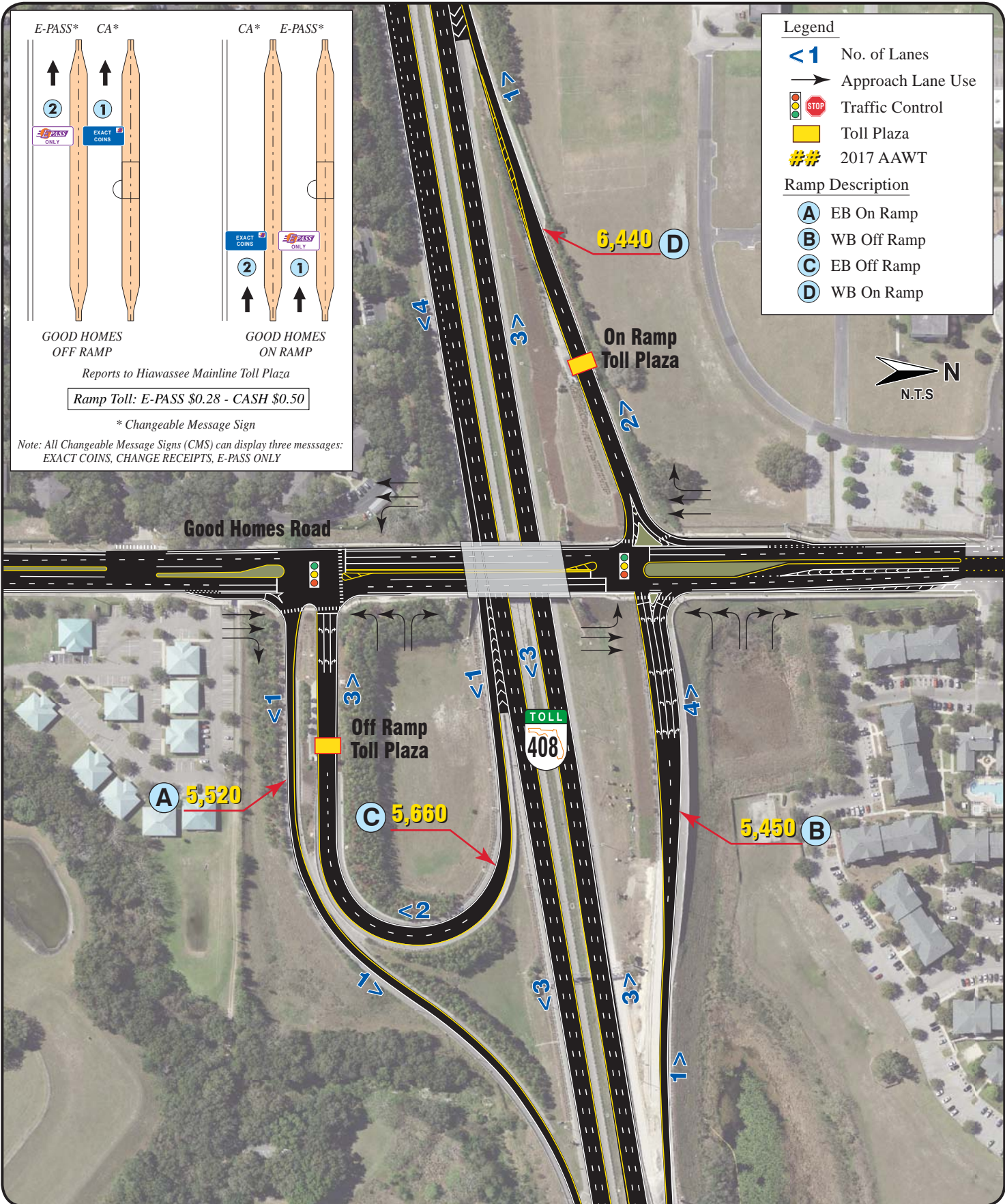

E-PASS CA*

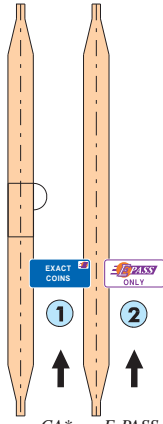
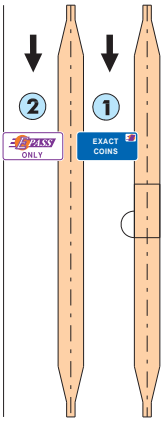

HIWASSEE ON RAMP

CA* E-PASS HIWASSEE OFF RAMP

Reports to Hiwassee Mainline Toll Plaza

Ramp Toll: E-PASS \$0.55 - CASH \$0.75

* Changeable Message Sign

Note: All Changeable Message Signs (CMS) can display three messages: EXACT COINS, CHANGE RECEIPTS, E-PASS ONLY

Legend



- <1 No. of Lanes
- Approach Lane Use
- Traffic Control
- Toll Plaza
- ## 2017 AAWT

Ramp Description

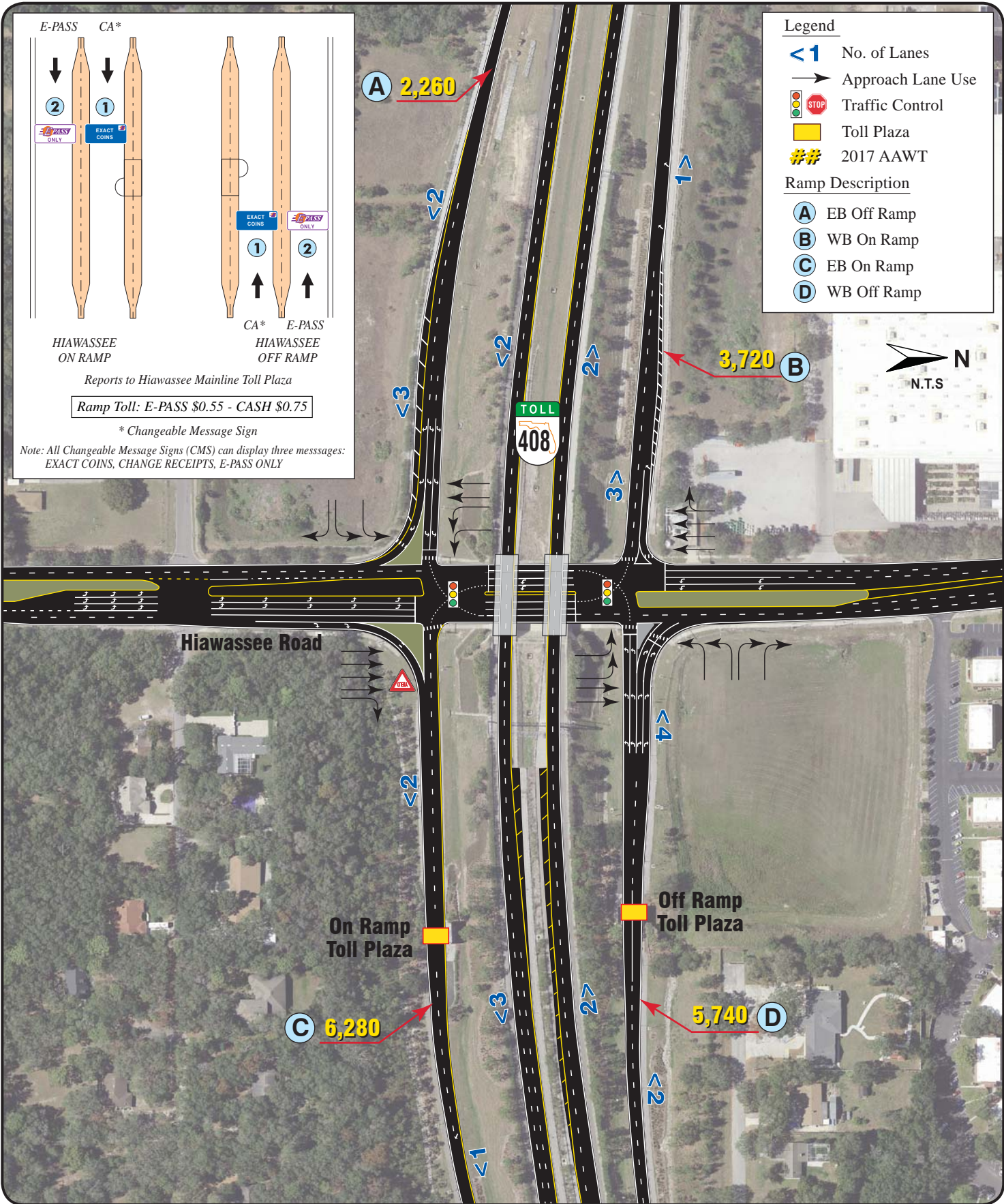



- A EB Off Ramp
- B WB On Ramp
- C EB On Ramp
- D WB Off Ramp



Legend

- <1 No. of Lanes
- Approach Lane Use
-   Traffic Control
-  Toll Plaza
- ## 2017 AAWT

Ramp Description

-  EB Off Ramp
-  WB On Ramp
-  EB On Ramp
-  WB Off Ramp

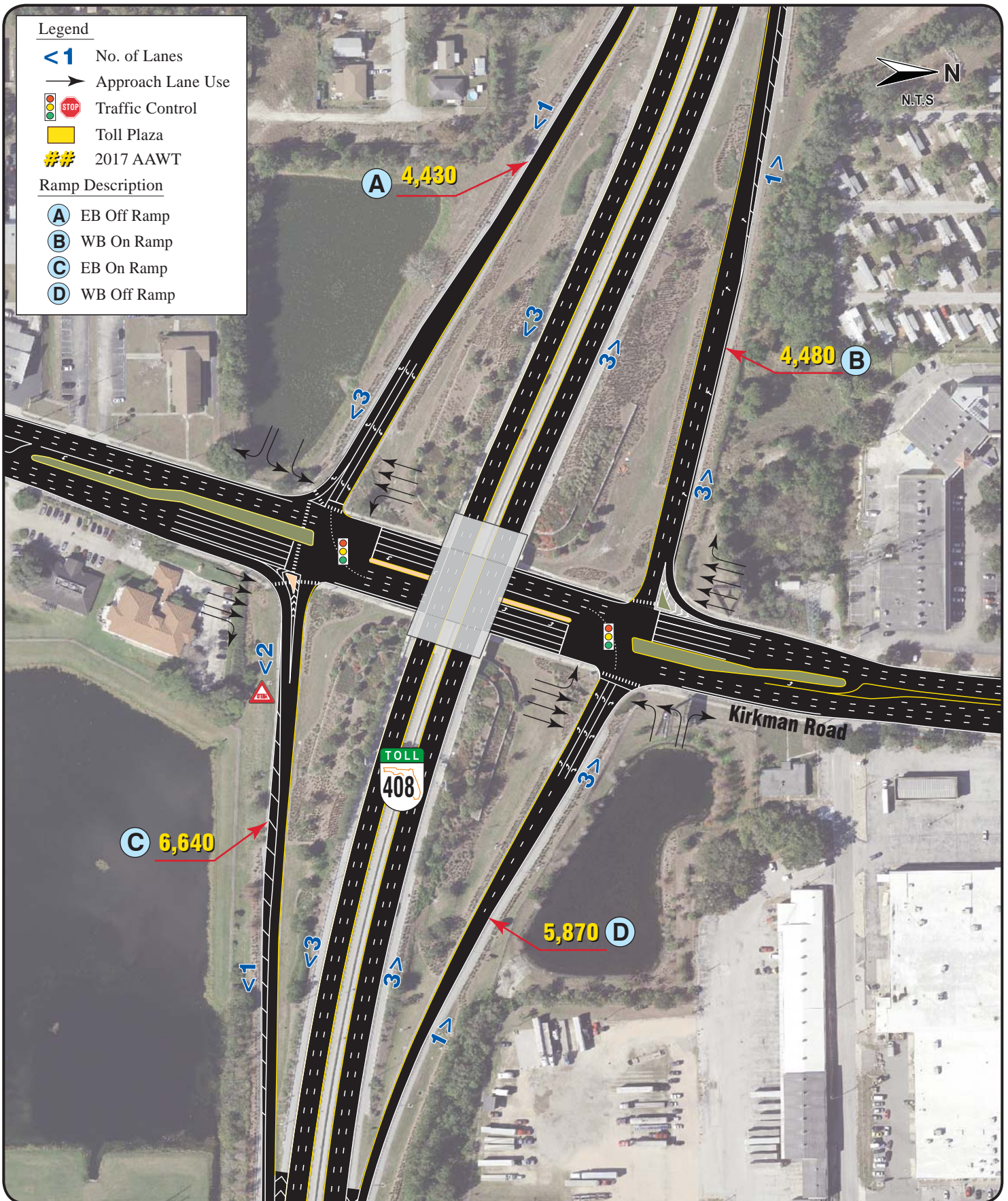

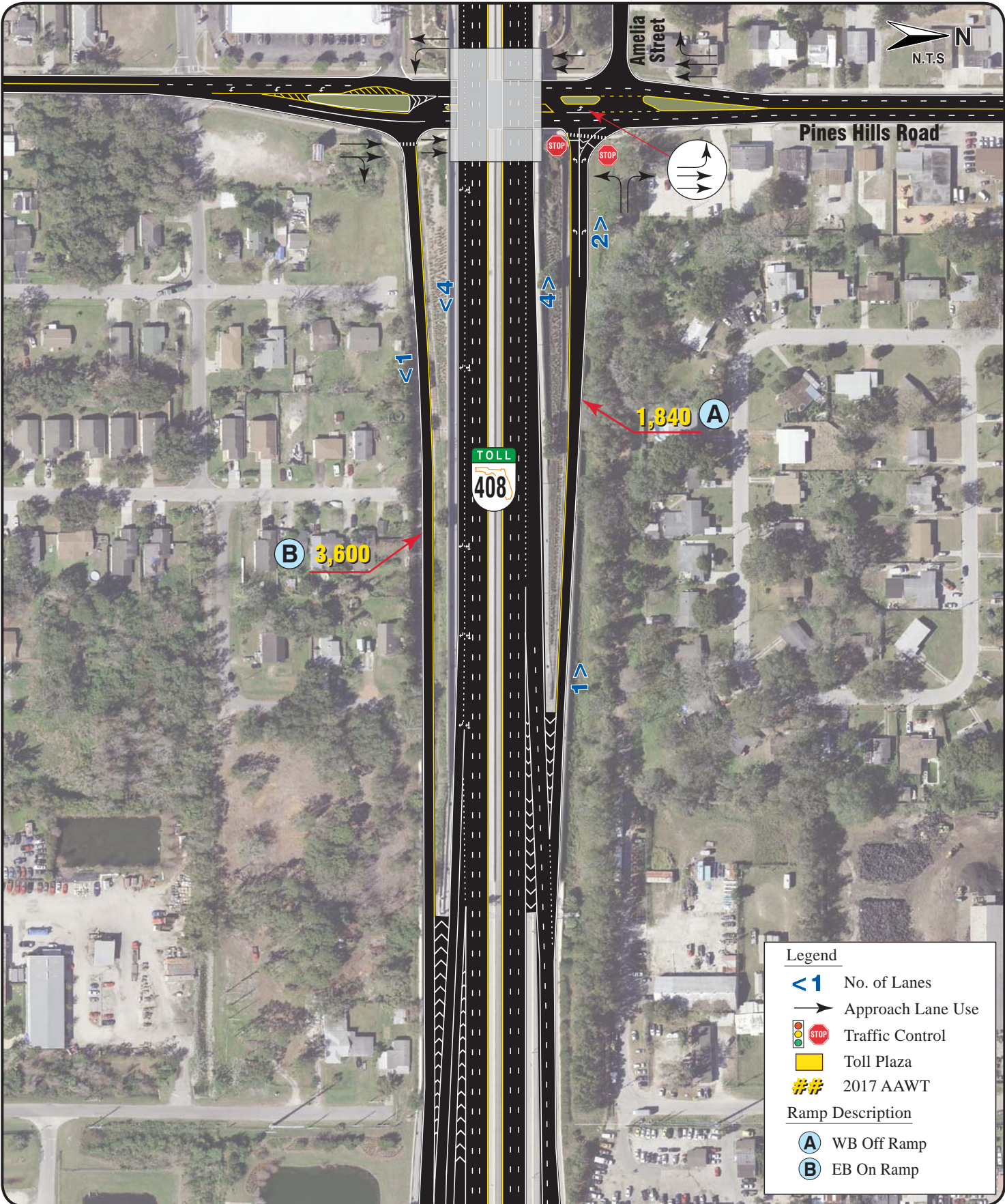

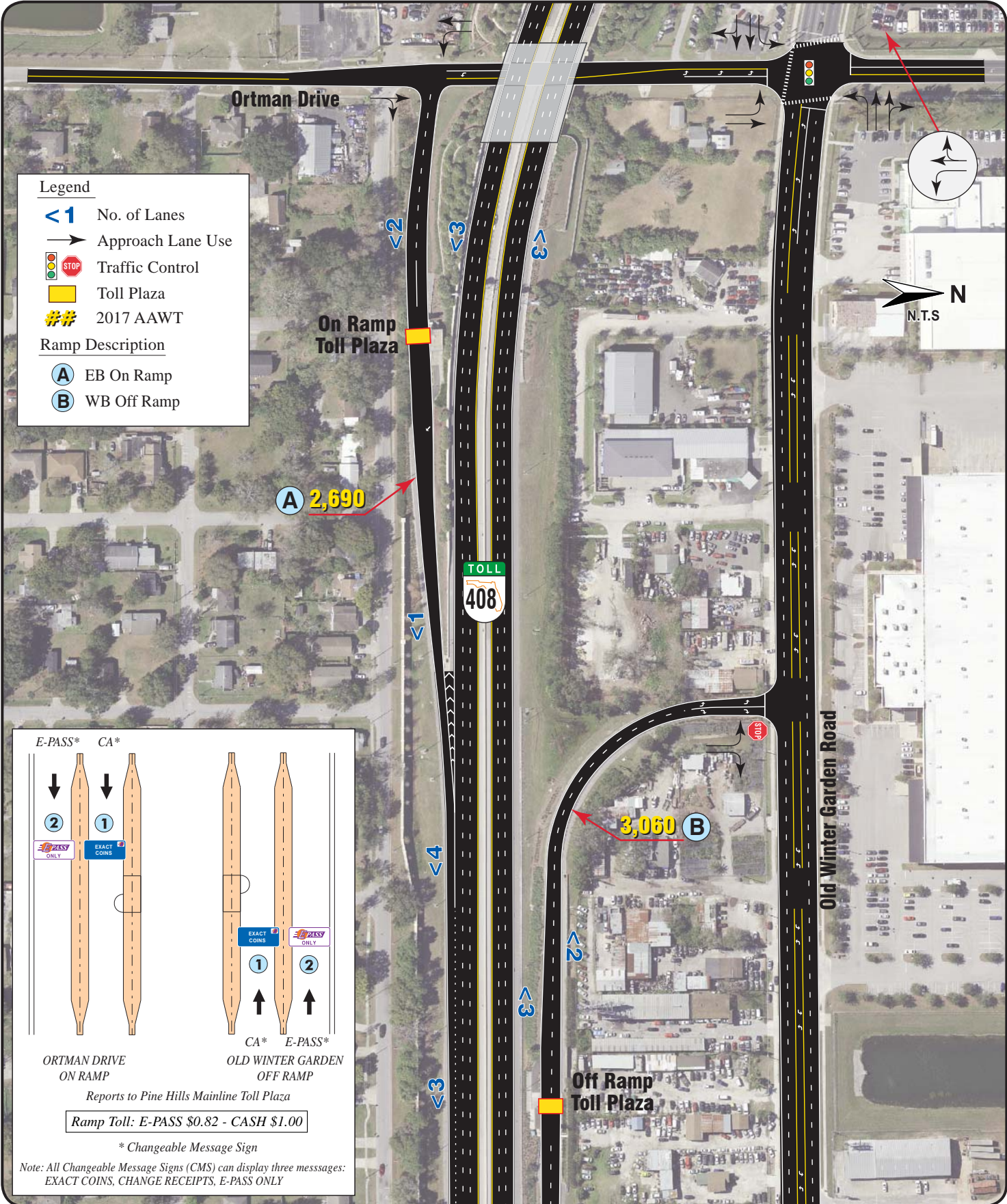

Legend	
<1>	No. of Lanes
→	Approach Lane Use
STOP	Traffic Control
##	2017 AAWT
Ramp Description	
(A)	WB Off Ramp
(B)	EB On Ramp



Legend

-  No. of Lanes
-  Approach Lane Use
-  Traffic Control
-  Toll Plaza
-  2017 AAWT

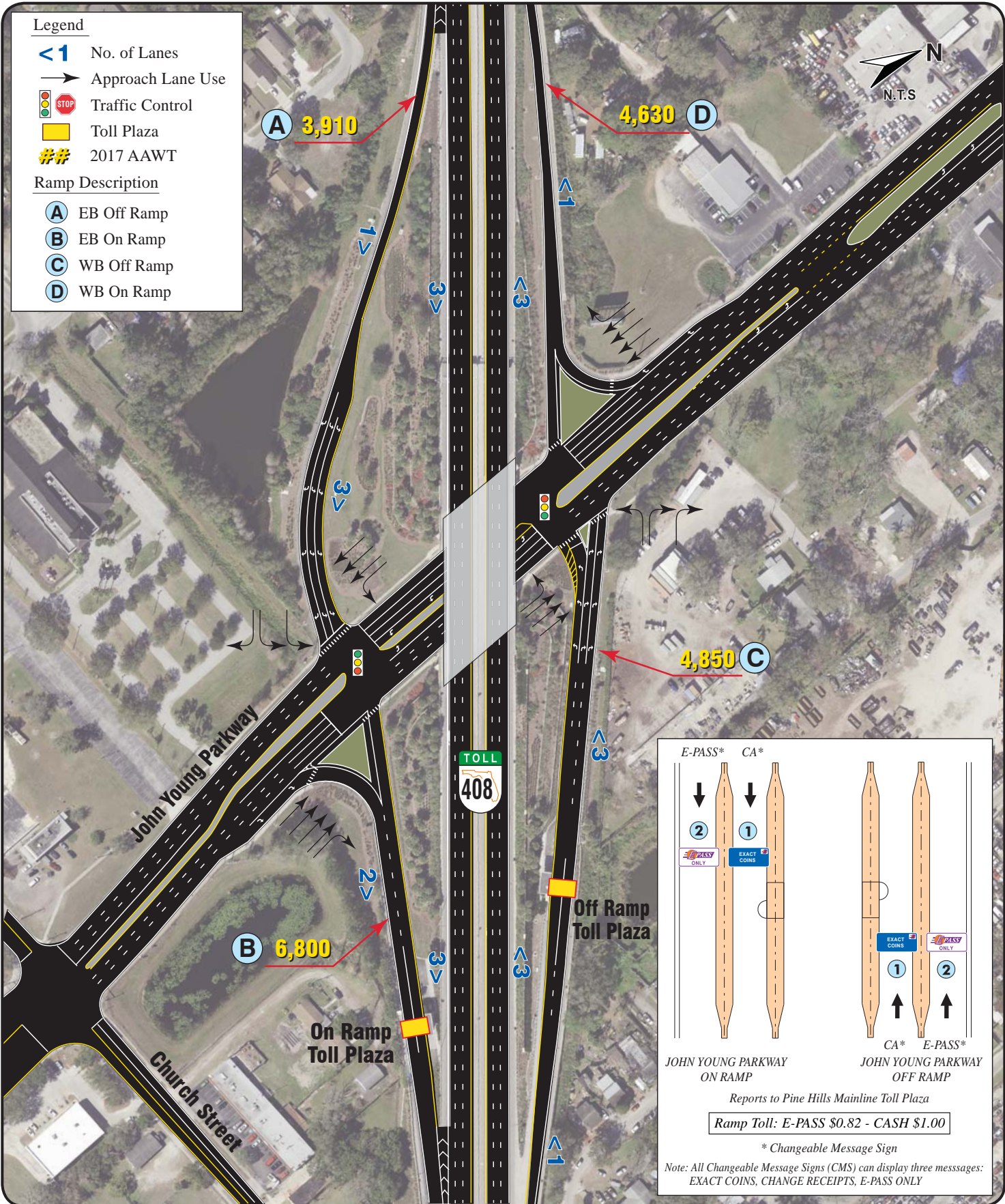

Ramp Description

-  EB Off Ramp
-  EB On Ramp
-  WB Off Ramp
-  WB On Ramp





E-PASS* ↓ ② E-PASS ONLY	CA* ↓ ① EXACT COINS	↑ ① EXACT COINS	↑ ② E-PASS ONLY
JOHN YOUNG PARKWAY ON RAMP		JOHN YOUNG PARKWAY OFF RAMP	
Reports to Pine Hills Mainline Toll Plaza			
Ramp Toll: E-PASS \$0.82 - CASH \$1.00			
* Changeable Message Sign			
Note: All Changeable Message Signs (CMS) can display three messages: EXACT COINS, CHANGE RECEIPTS, E-PASS ONLY			

Legend

- <1 No. of Lanes
- Approach Lane Use
-  Traffic Control
-  Toll Plaza
- ## 2017 AAWT

Ramp Description

-  EB Off Ramp
-  WB On Ramp

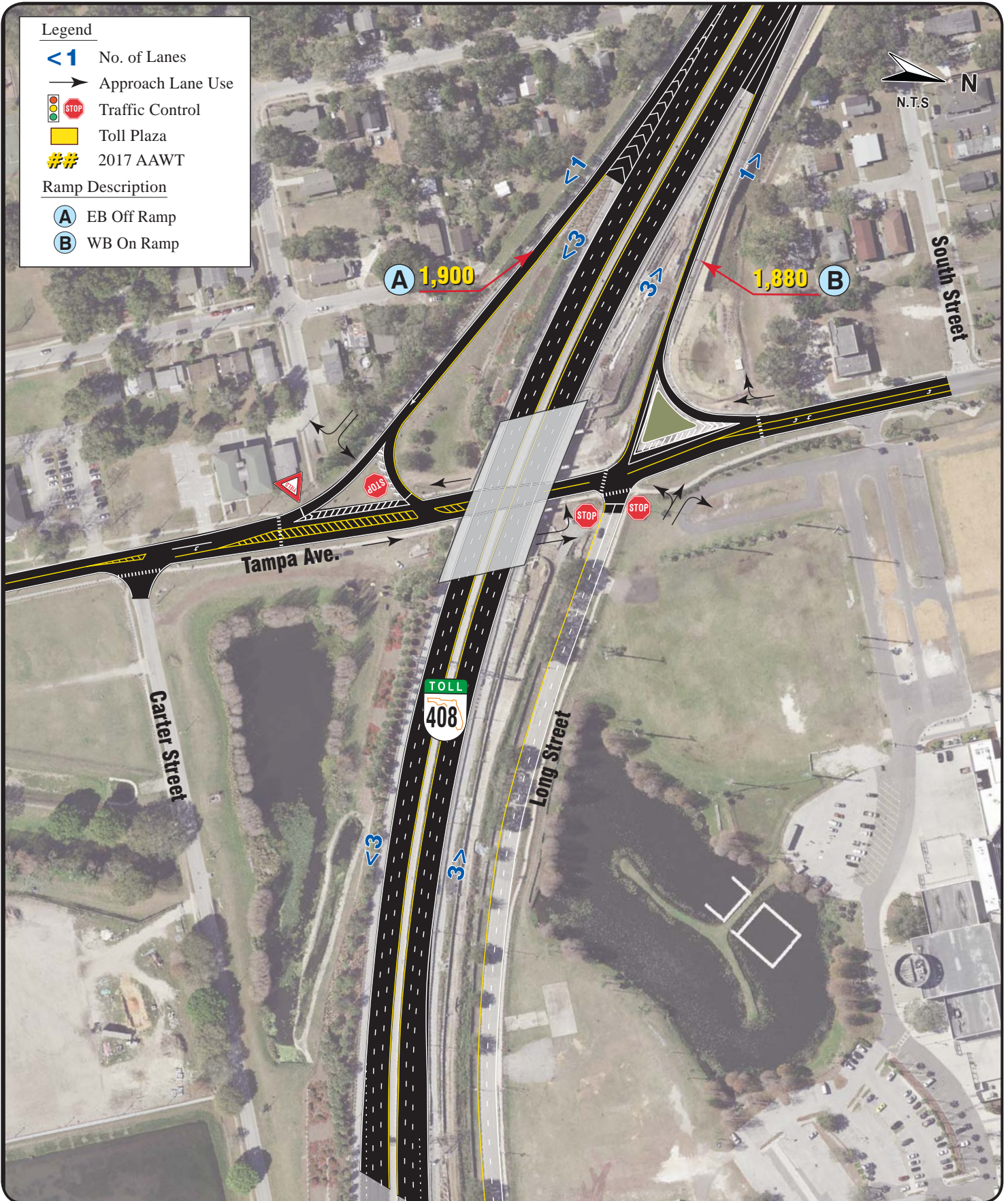

Legend

- <1 No. of Lanes
- ➔ Approach Lane Use
- 🚦 STOP Traffic Control
- 🟡 Toll Plaza
- ## 2017 AAWT

Ramp Description

- (A) EB Off Ramp
- (B) WB On Ramp
- (C) EB On Ramp
- (D) WB Off Ramp

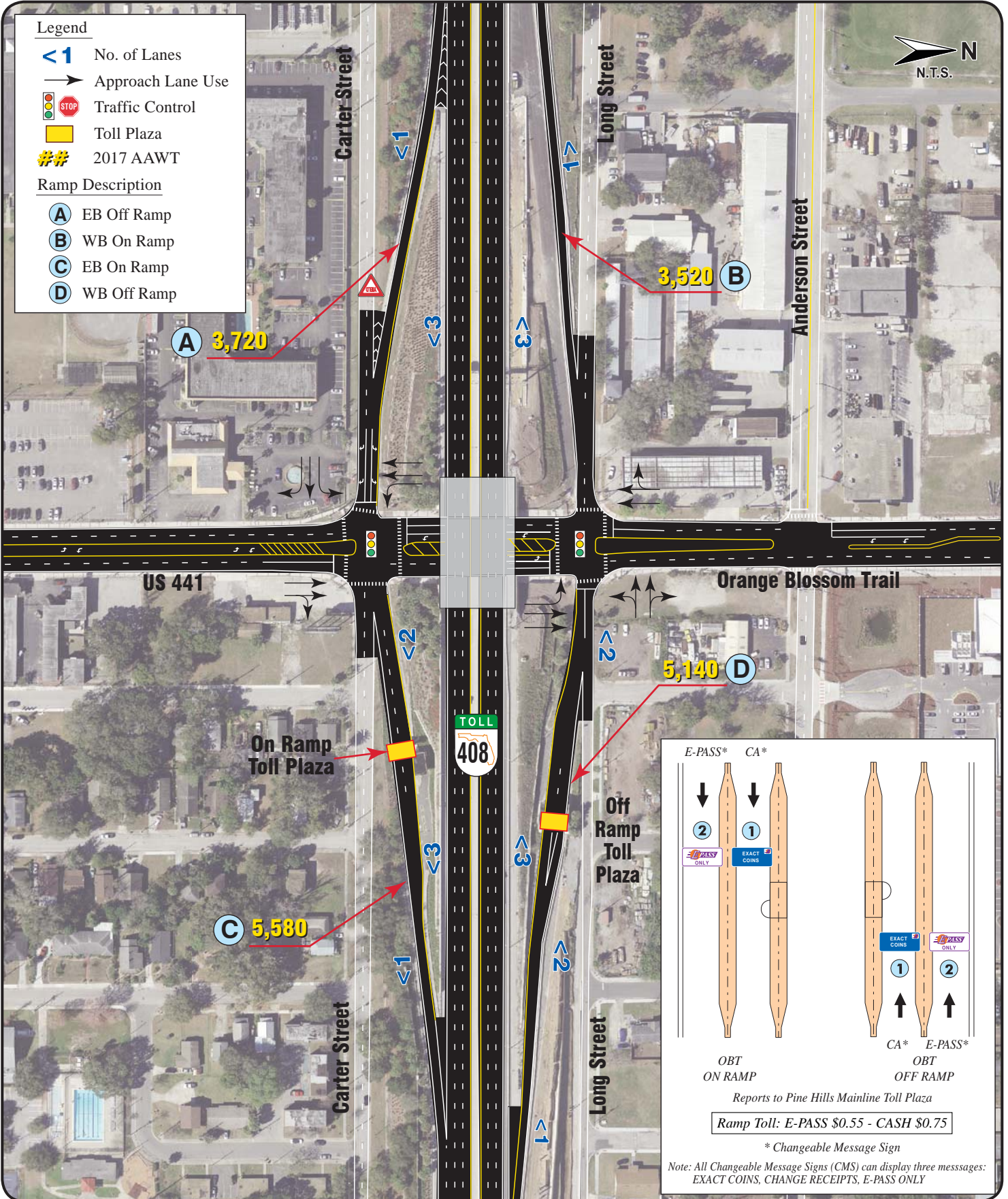

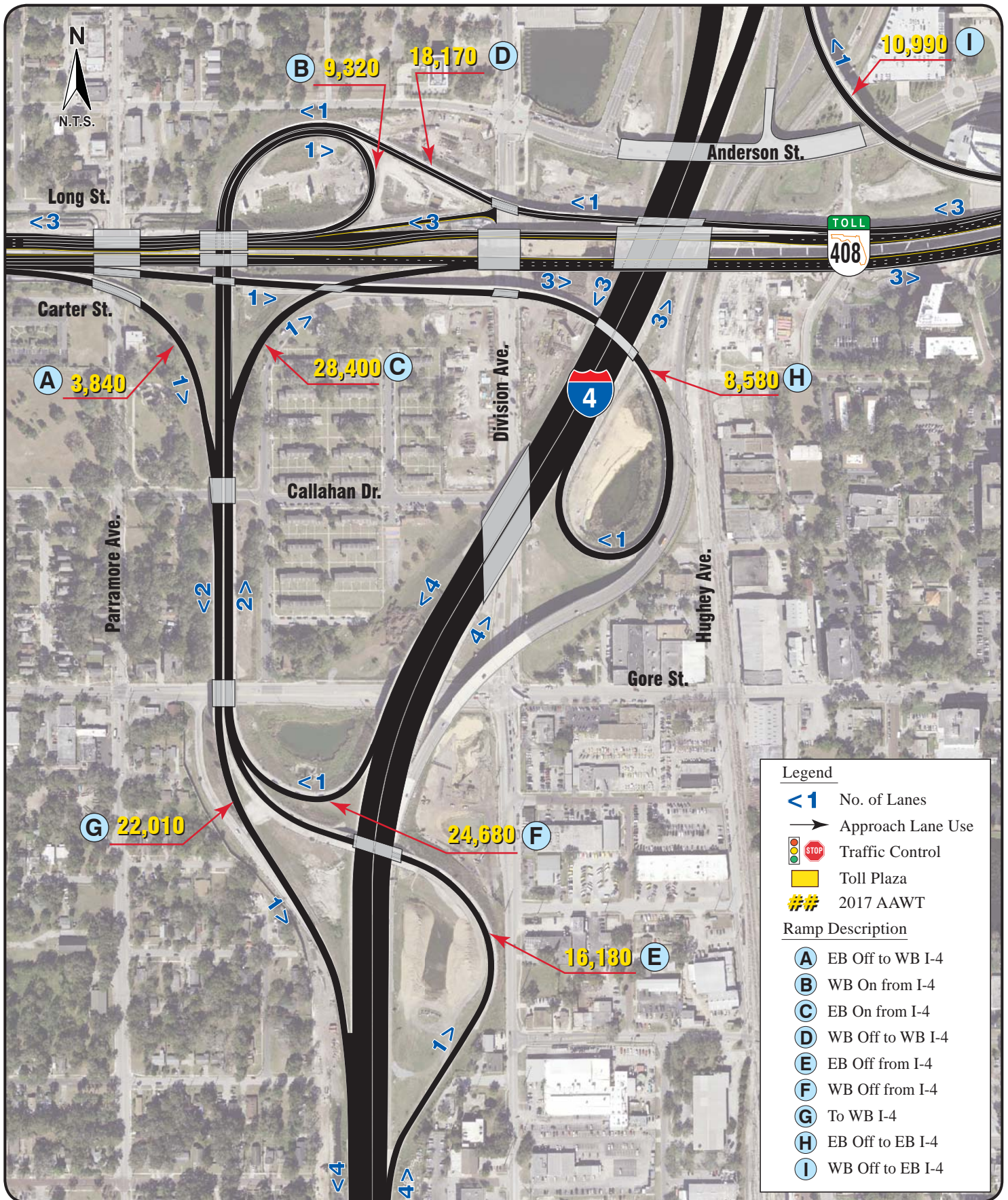

Legend





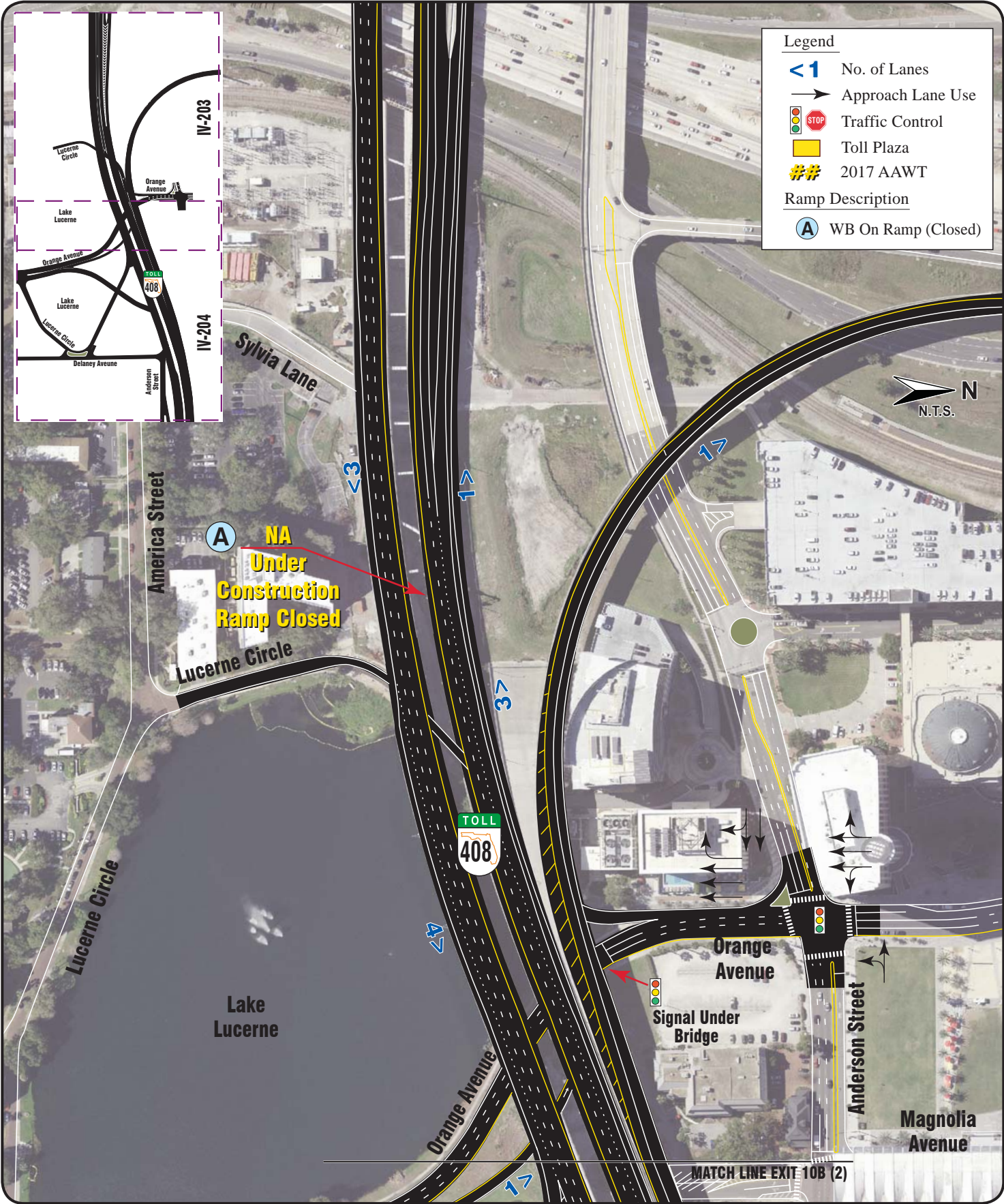

- <1 No. of Lanes
- Approach Lane Use
- STOP Traffic Control
- Toll Plaza
- ## 2017 AAWT

Ramp Description

- (A) EB Off to WB I-4
- (B) WB On from I-4
- (C) EB On from I-4
- (D) WB Off to WB I-4
- (E) EB Off from I-4
- (F) WB Off from I-4
- (G) To WB I-4
- (H) EB Off to EB I-4
- (I) WB Off to EB I-4







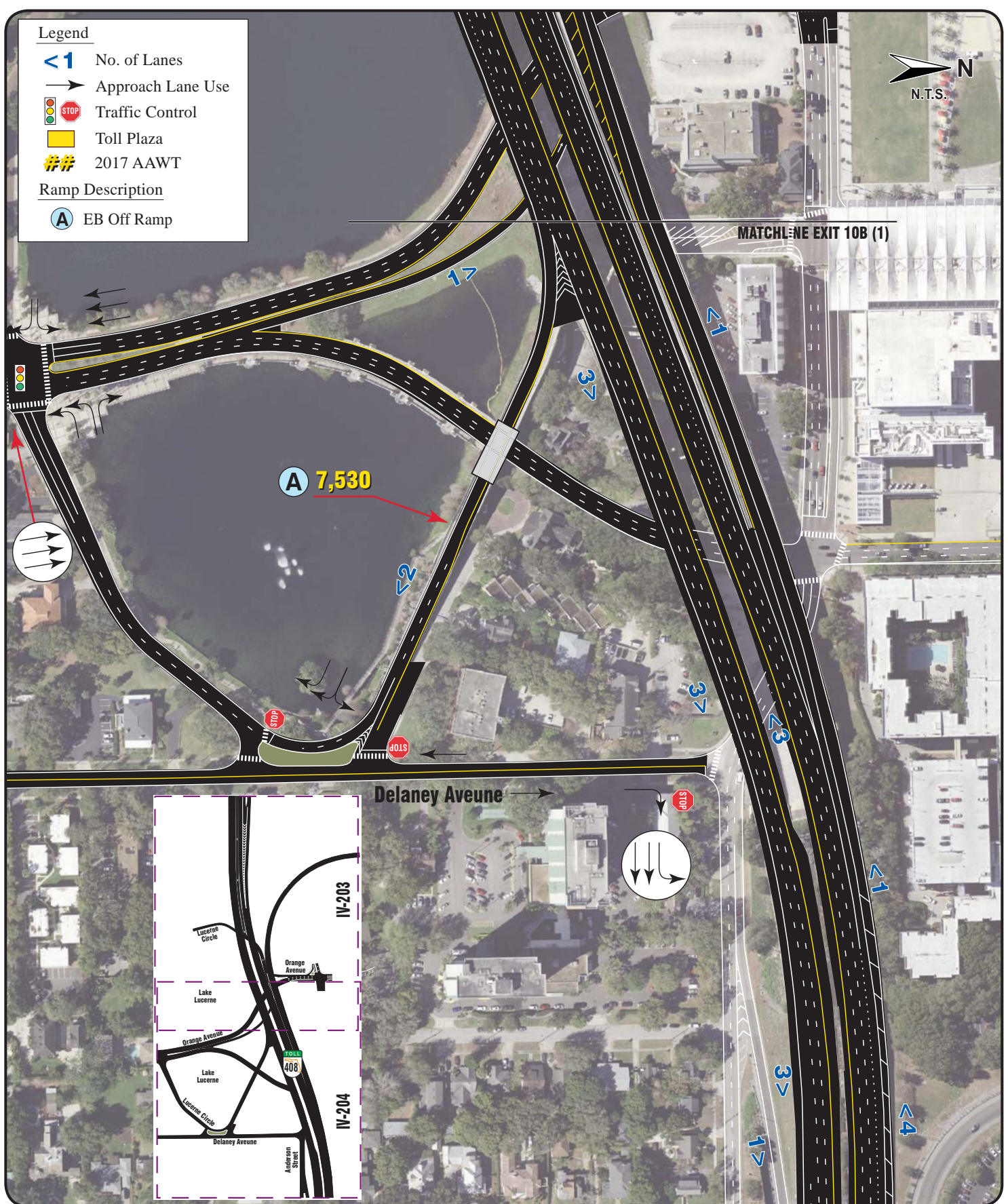

Legend

-  No. of Lanes
-  Approach Lane Use
-  Traffic Control
-  Toll Plaza
-  2017 AAWT
- Ramp Description**
-  EB Off Ramp





**SR 408 (EAST-WEST EXPRESSWAY)
Exit 10C - Orange Avenue (2)**

Legend

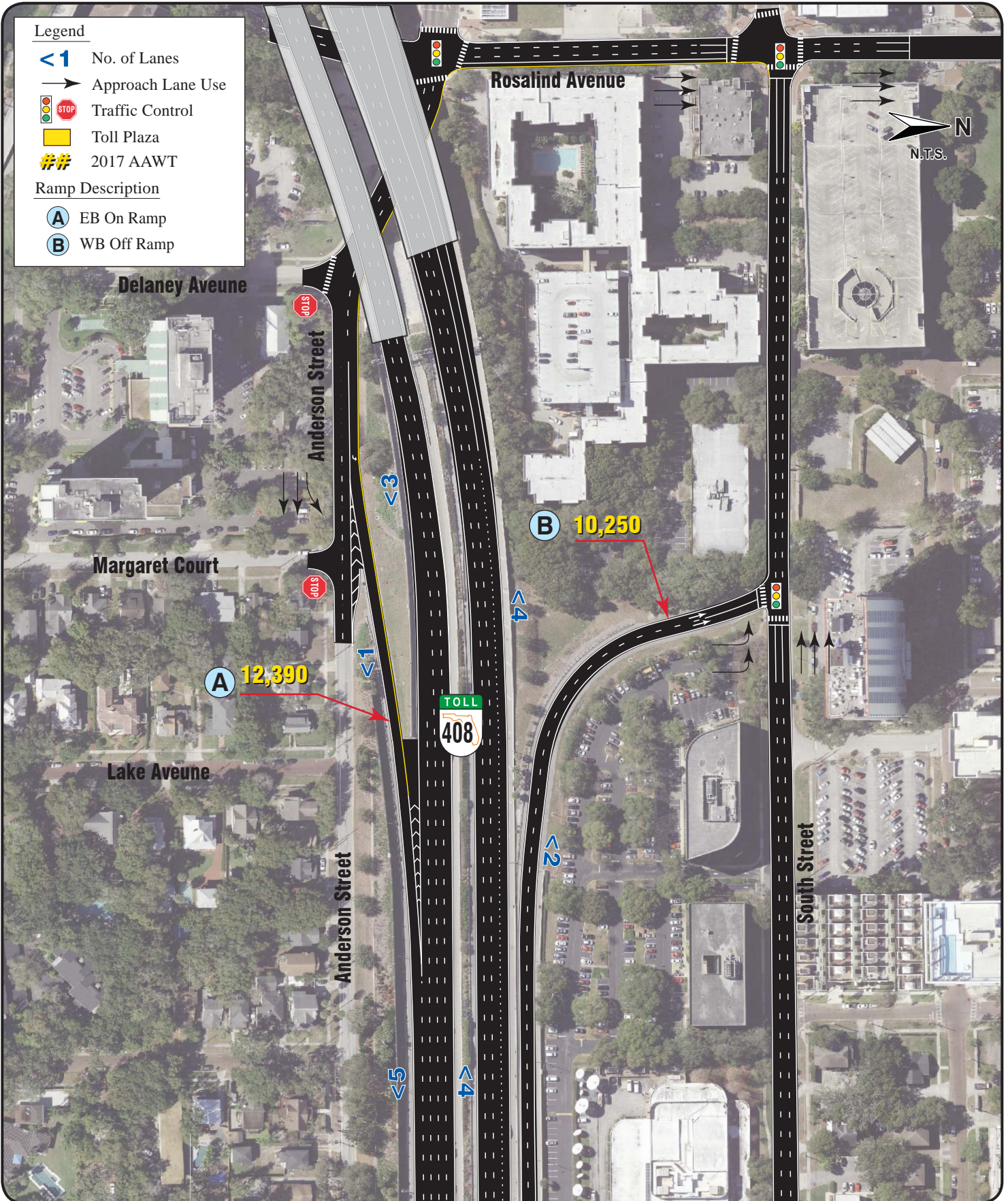

-  No. of Lanes
-  Approach Lane Use
-  Traffic Control
-  Toll Plaza
-  2017 AAWT
- Ramp Description**
-  EB On Ramp
-  WB Off Ramp



Legend

-  No. of Lanes
-  Approach Lane Use
-  Traffic Control
-  Toll Plaza
-  2017 AAWT

Ramp Description

-  EB Off Ramp
-  WB Off Ramp
-  EB On Ramp

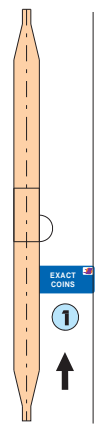

CA*
MILLS
OFF RAMP

Reports to Conway Mainline Toll Plaza



Ramp Toll: E-PASS \$0.55 - CASH \$0.75

* Changeable Message Sign

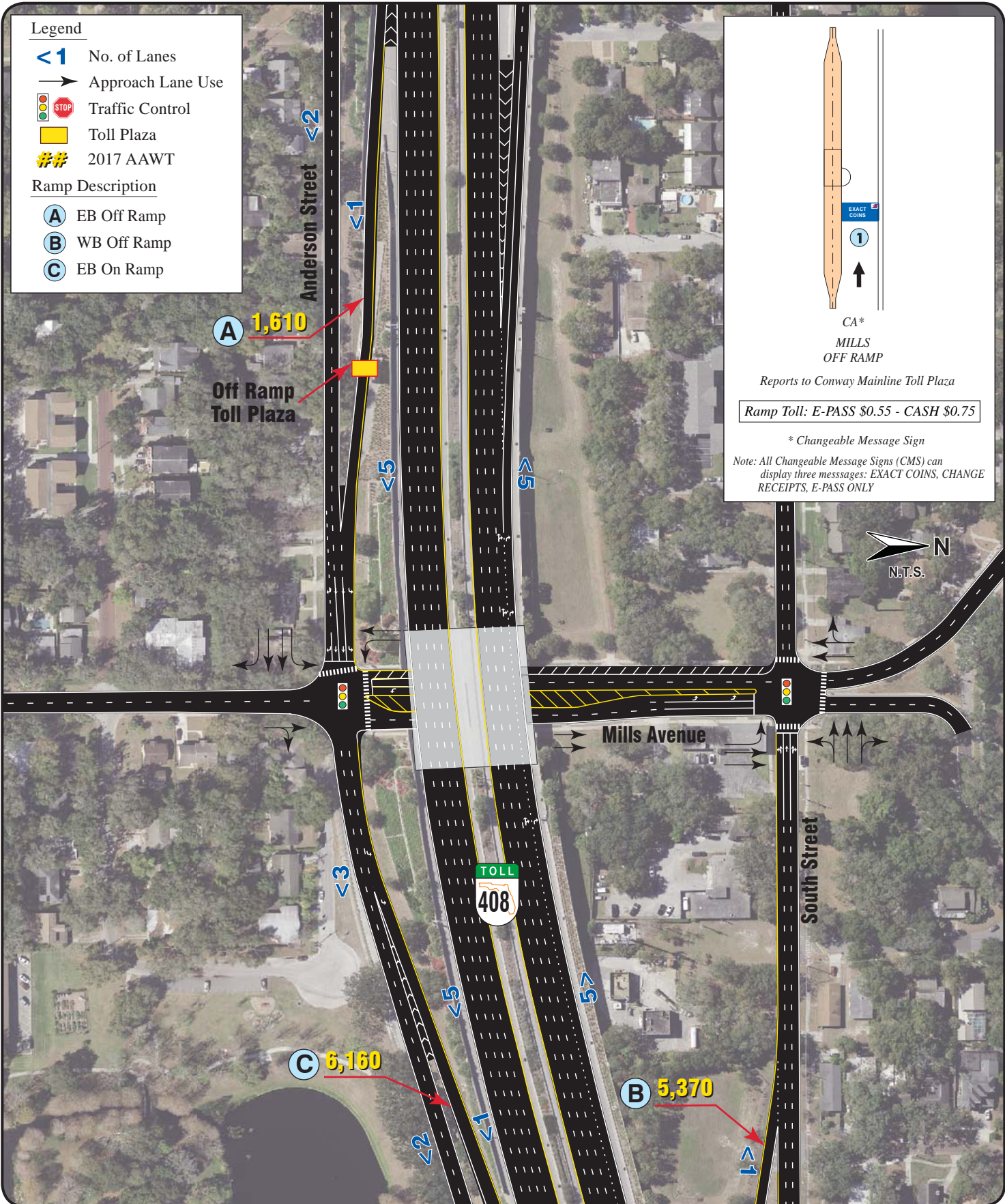

Note: All Changeable Message Signs (CMS) can display three messages: EXACT COINS, CHANGE RECEIPTS, E-PASS ONLY



Legend



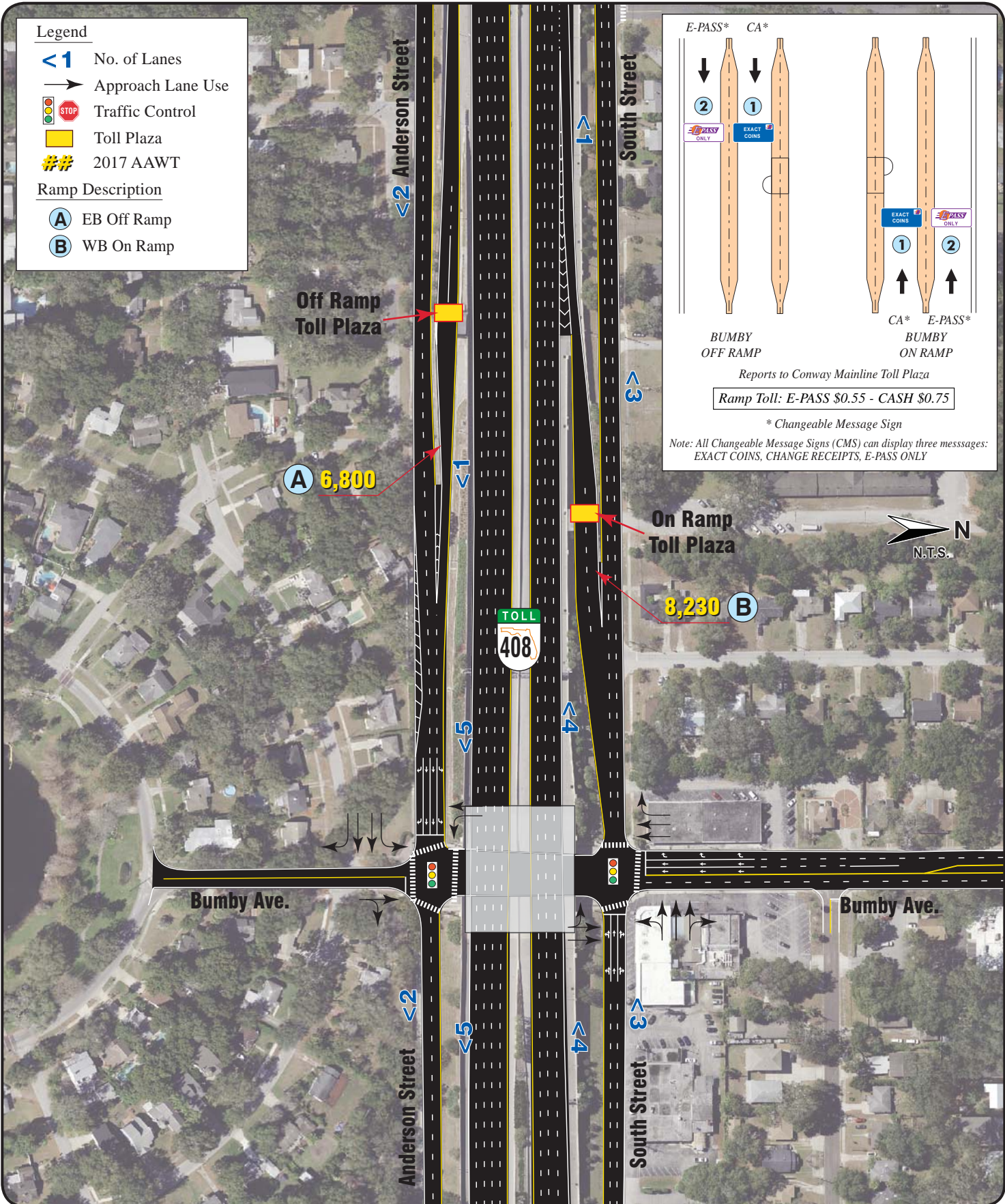
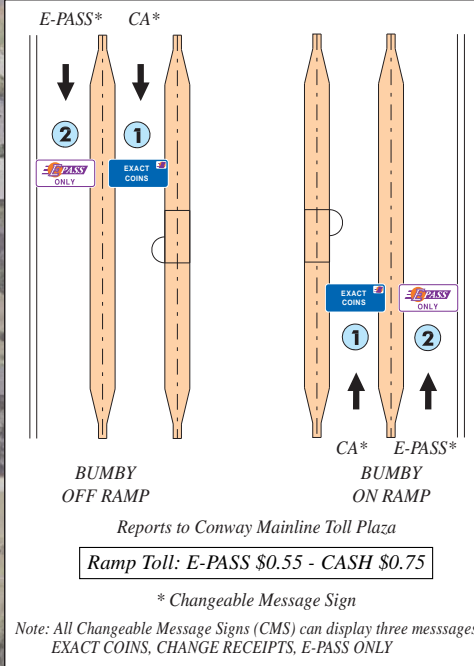

- < 1 No. of Lanes
- Approach Lane Use
-  Traffic Control
-  Toll Plaza
-  2017 AAWT

Ramp Description



-  EB Off Ramp
-  WB On Ramp



Legend

-  No. of Lanes
-  Approach Lane Use
-  Traffic Control
-  Toll Plaza
-  2017 AAWT

Ramp Description

-  WB Off Ramp
-  EB On Ramp

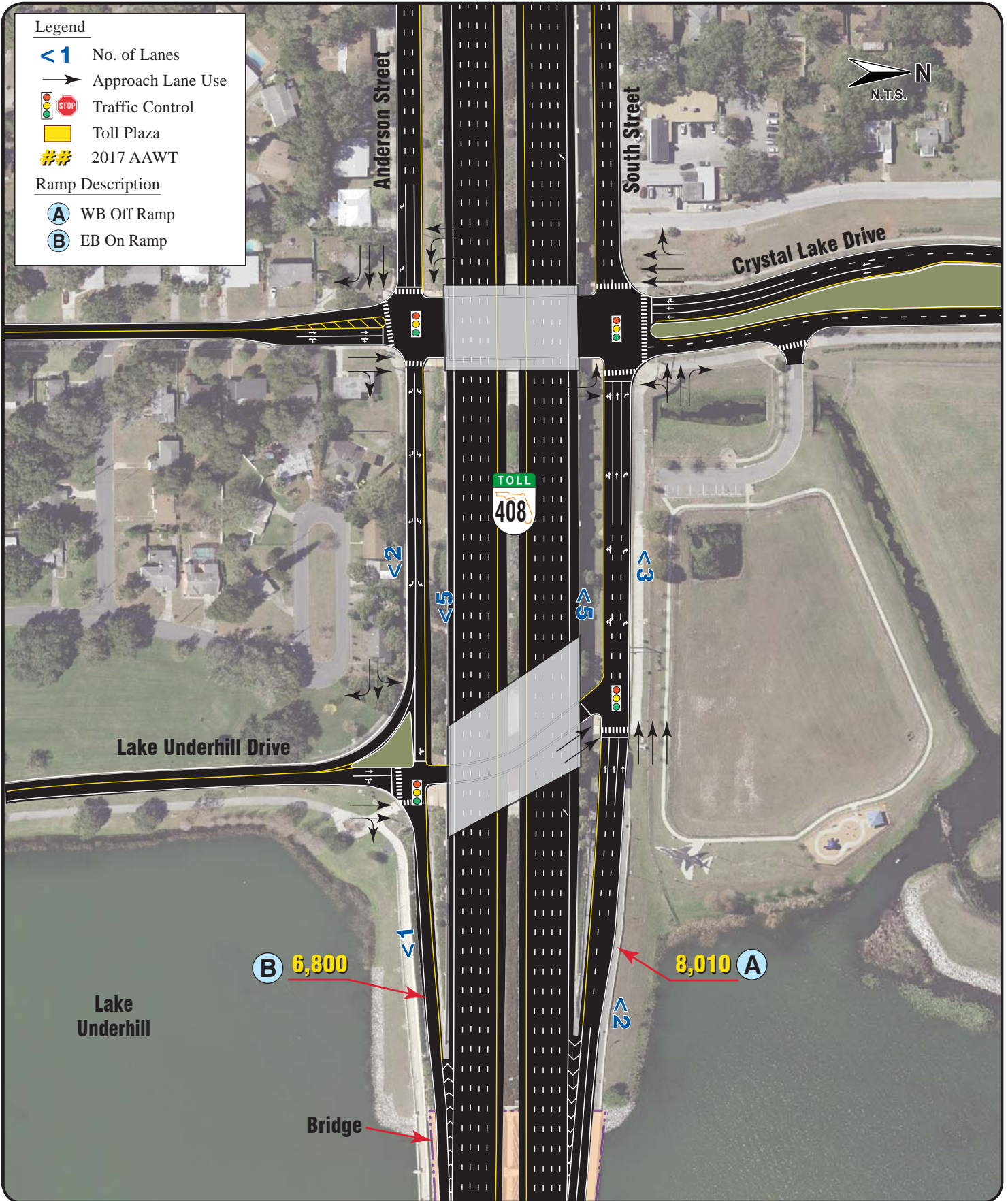

E-PASS* MCA*

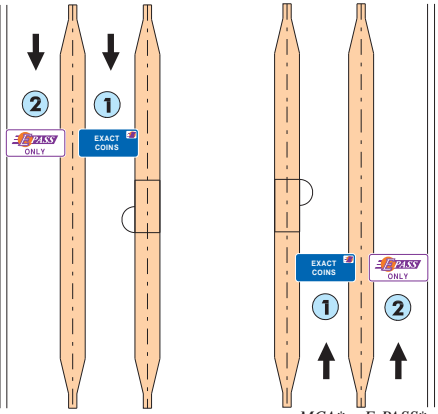

CONWAY
OFF RAMP

MCA* E-PASS*
CONWAY
ON RAMP

Reports to Conway Mainline Toll Plaza

Ramp Toll: E-PASS \$0.82 - CASH \$1.00

* Changeable Message Sign

Note: All Changeable Message Signs (CMS) can display three messages:
EXACT COINS, CHANGE RECEIPTS, E-PASS ONLY

Legend

- <1 No. of Lanes
- Approach Lane Use
- STOP Traffic Control
- Toll Plaza
- ## 2017 AAWT

Ramp Description

- A WB On Ramp
- B EB Off Ramp



SR 408 (EAST-WEST EXPRESSWAY)
Exit 13 - Conway Road

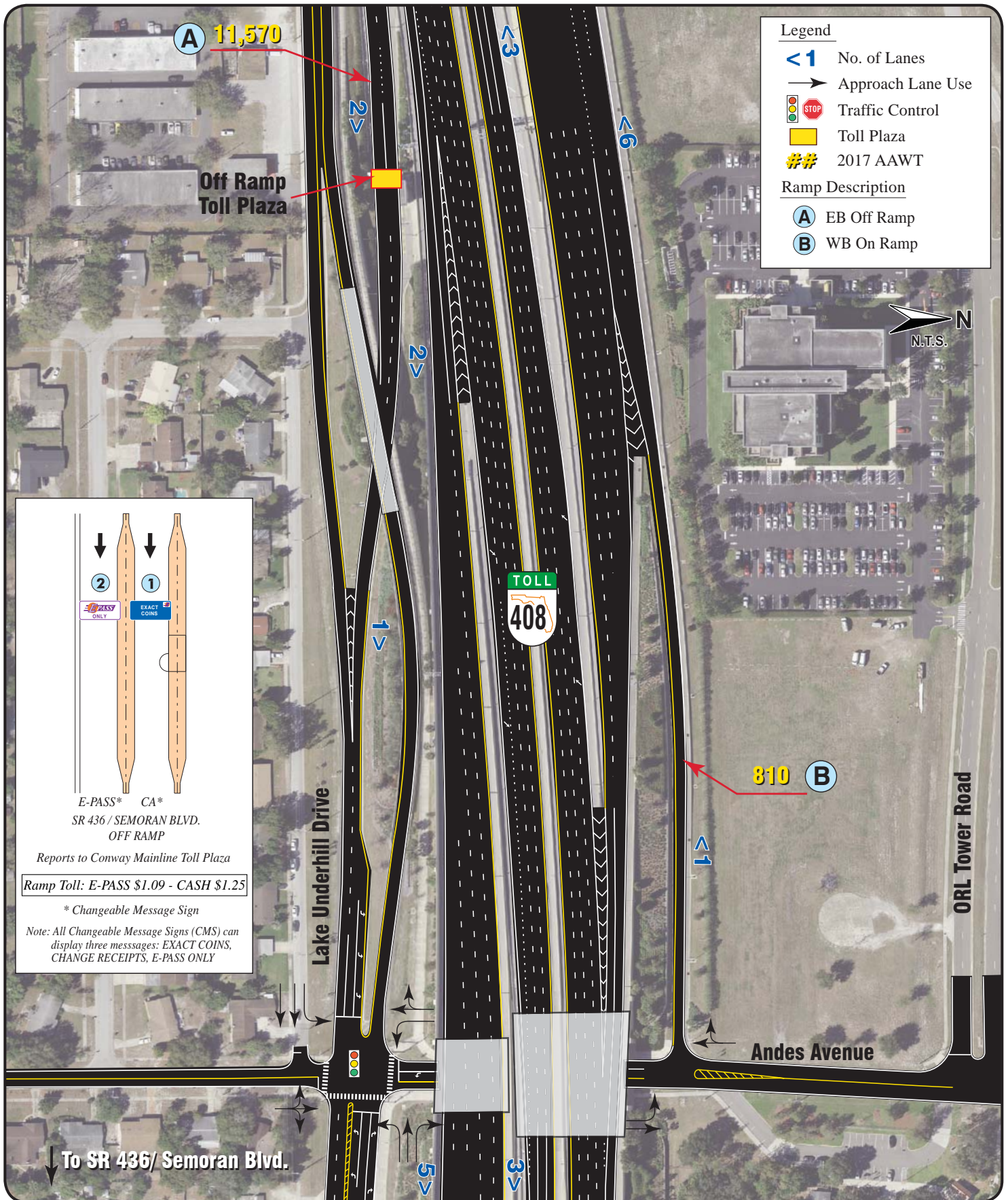

Legend

- < 1 No. of Lanes
- Approach Lane Use
- STOP Traffic Control
- Yellow Box Toll Plaza
- ## 2017 AAWT

Ramp Description

- (A) EB Off Ramp
- (B) WB On Ramp

E-PASS* CA*
 SR 436 / SEMORAN BLVD.
 OFF RAMP





Reports to Conway Mainline Toll Plaza

Ramp Toll: E-PASS \$1.09 - CASH \$1.25



* Changeable Message Sign

Note: All Changeable Message Signs (CMS) can display three messages: EXACT COINS, CHANGE RECEIPTS, E-PASS ONLY

Legend

-  No. of Lanes
-  Approach Lane Use
-  Traffic Control
-  Toll Plaza
-  2017 AAWT

Ramp Description

-  WB On Ramp
-  WB On Loop Ramp
-  WB Off Ramp

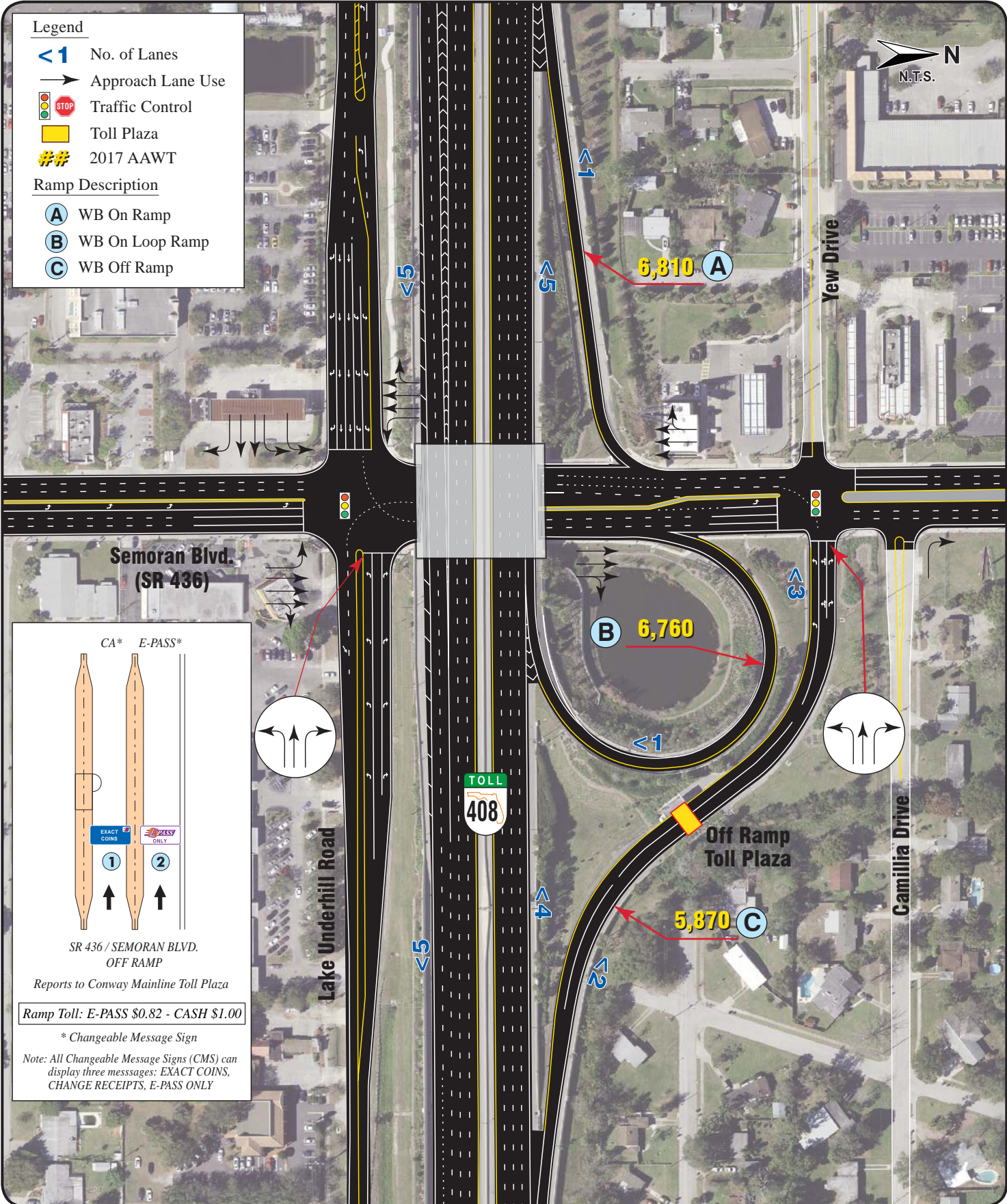

Semoran Blvd. (SR 436)

SR 436 / SEMORAN BLVD.
OFF RAMP

Reports to Conway Mainline Toll Plaza

Ramp Toll: E-PASS \$0.82 - CASH \$1.00

** Changeable Message Sign*

Note: All Changeable Message Signs (CMS) can display three messages: EXACT COINS, CHANGE RECEIPTS, E-PASS ONLY

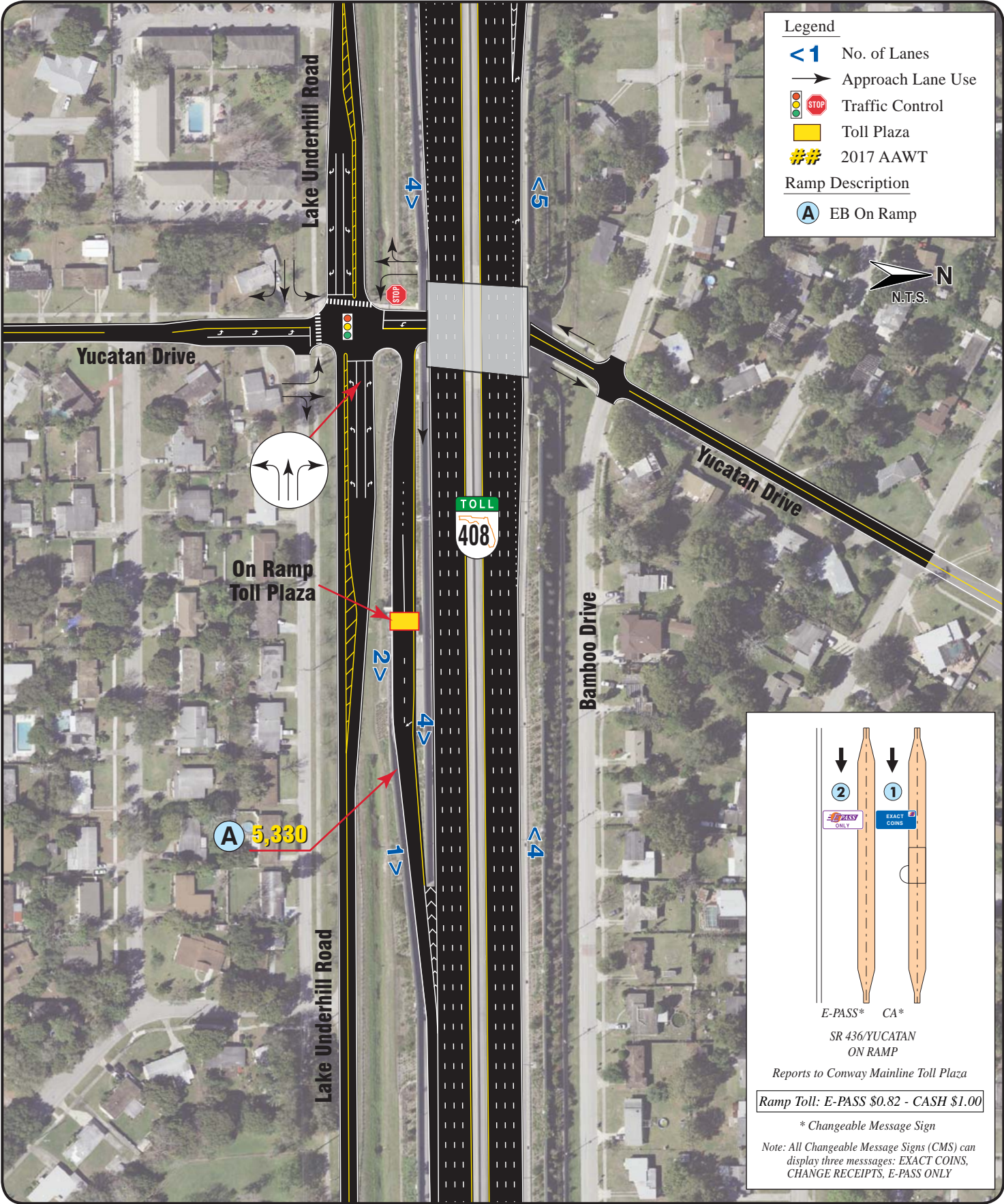

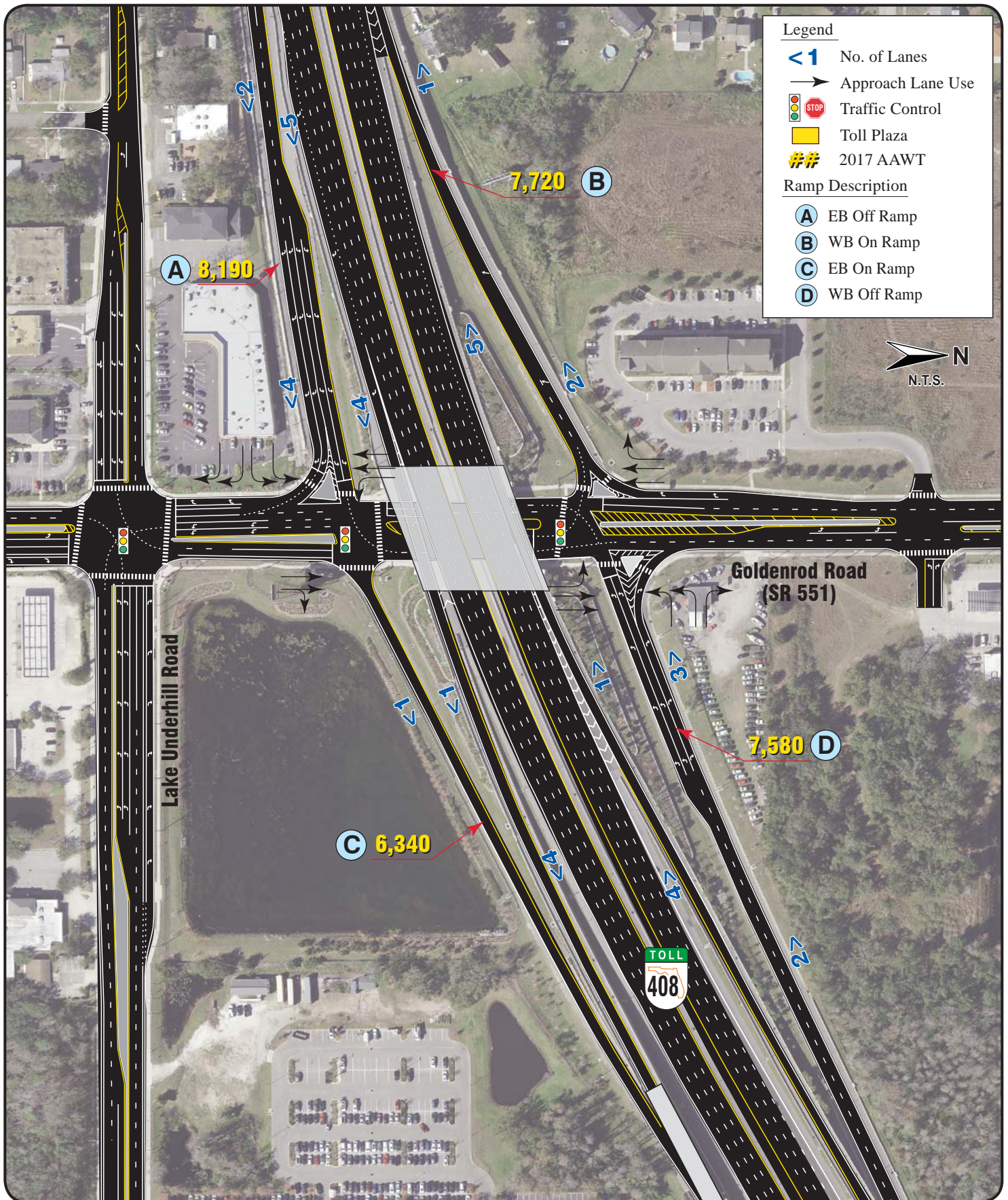

Legend

- <1 No. of Lanes
- Approach Lane Use
- 🚦 STOP Traffic Control
- 🟡 Toll Plaza
- ## 2017 AAWT

Ramp Description

- Ⓐ EB Off Ramp
- Ⓑ WB On Ramp
- Ⓒ EB On Ramp
- Ⓓ WB Off Ramp





Legend

- <1> No. of Lanes
- Approach Lane Use
- Traffic Control
- Toll Plaza
- 2017 AAWT

Ramp Description

- EB Off Ramp
- WB On Ramp

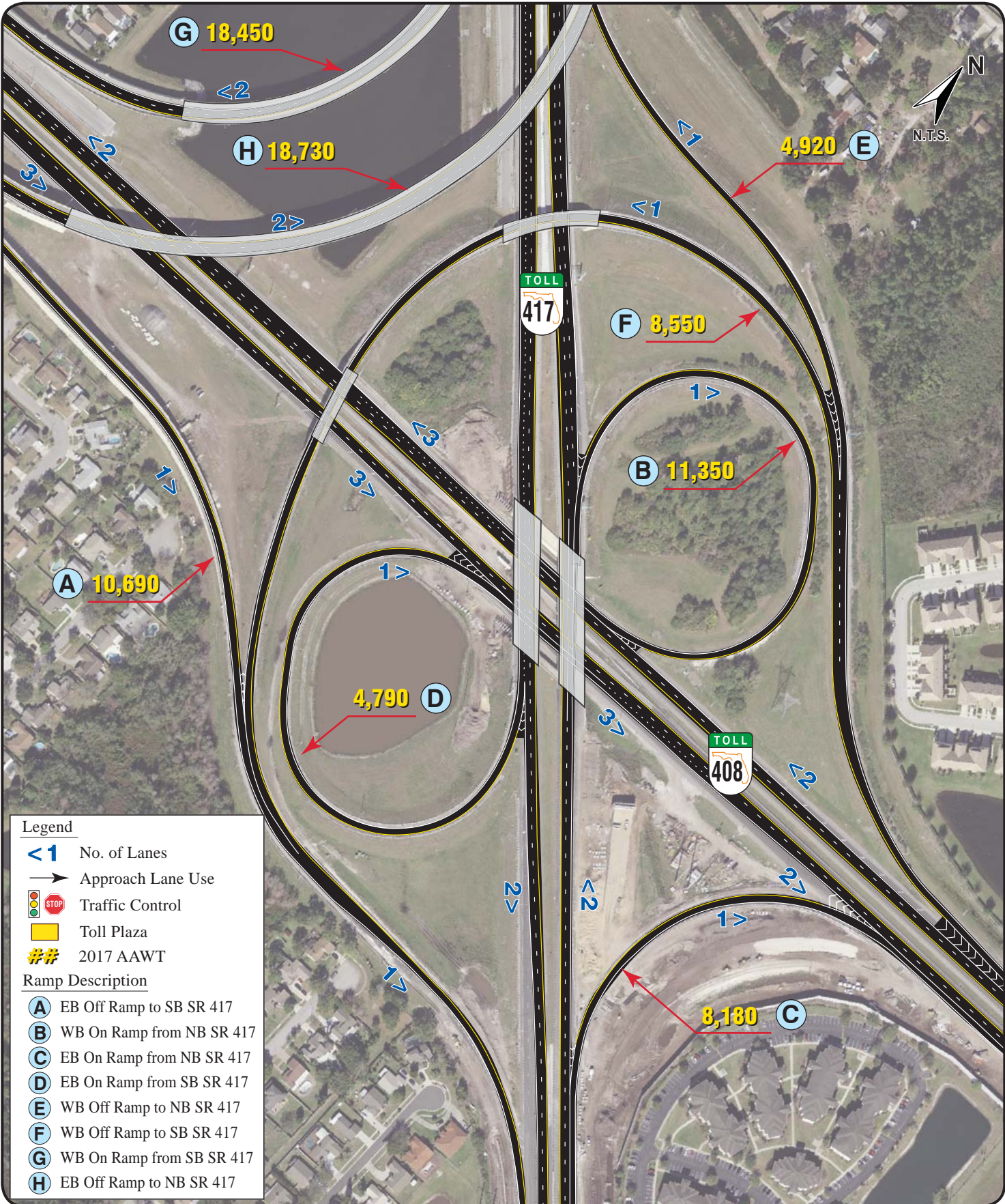

Legend

- <1 No. of Lanes
- Approach Lane Use
- STOP Traffic Control
- Yellow Box Toll Plaza
- ## 2017 AAWT

Ramp Description

- (A) EB Off Ramp to SB SR 417
- (B) WB On Ramp from NB SR 417
- (C) EB On Ramp from NB SR 417
- (D) EB On Ramp from SB SR 417
- (E) WB Off Ramp to NB SR 417
- (F) WB Off Ramp to SB SR 417
- (G) WB On Ramp from SB SR 417
- (H) EB Off Ramp to NB SR 417

Legend

- <1 No. of Lanes
- ➔ Approach Lane Use
- 🚦 Traffic Control
- 🟡 Toll Plaza
- ## 2017 AAWT

Ramp Description

- Ⓐ EB Off Ramp
- Ⓑ WB On Ramp
- Ⓒ EB On Ramp
- Ⓓ WB Off Ramp

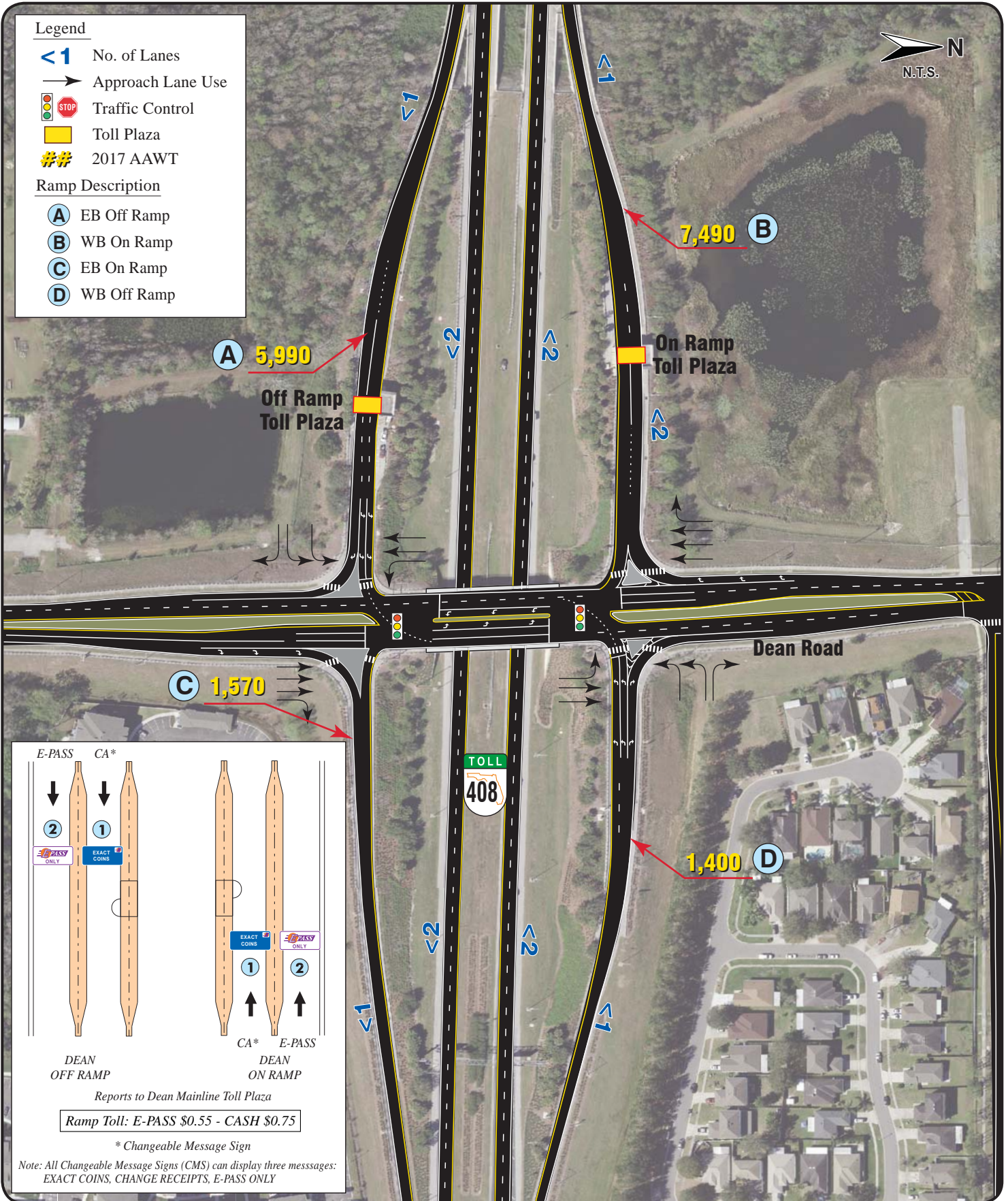

E-PASS CA*

DEAN OFF RAMP DEAN ON RAMP

Reports to Dean Mainline Toll Plaza

Ramp Toll: E-PASS \$0.55 - CASH \$0.75

** Changeable Message Sign*

Note: All Changeable Message Signs (CMS) can display three messages: EXACT COINS, CHANGE RECEIPTS, E-PASS ONLY

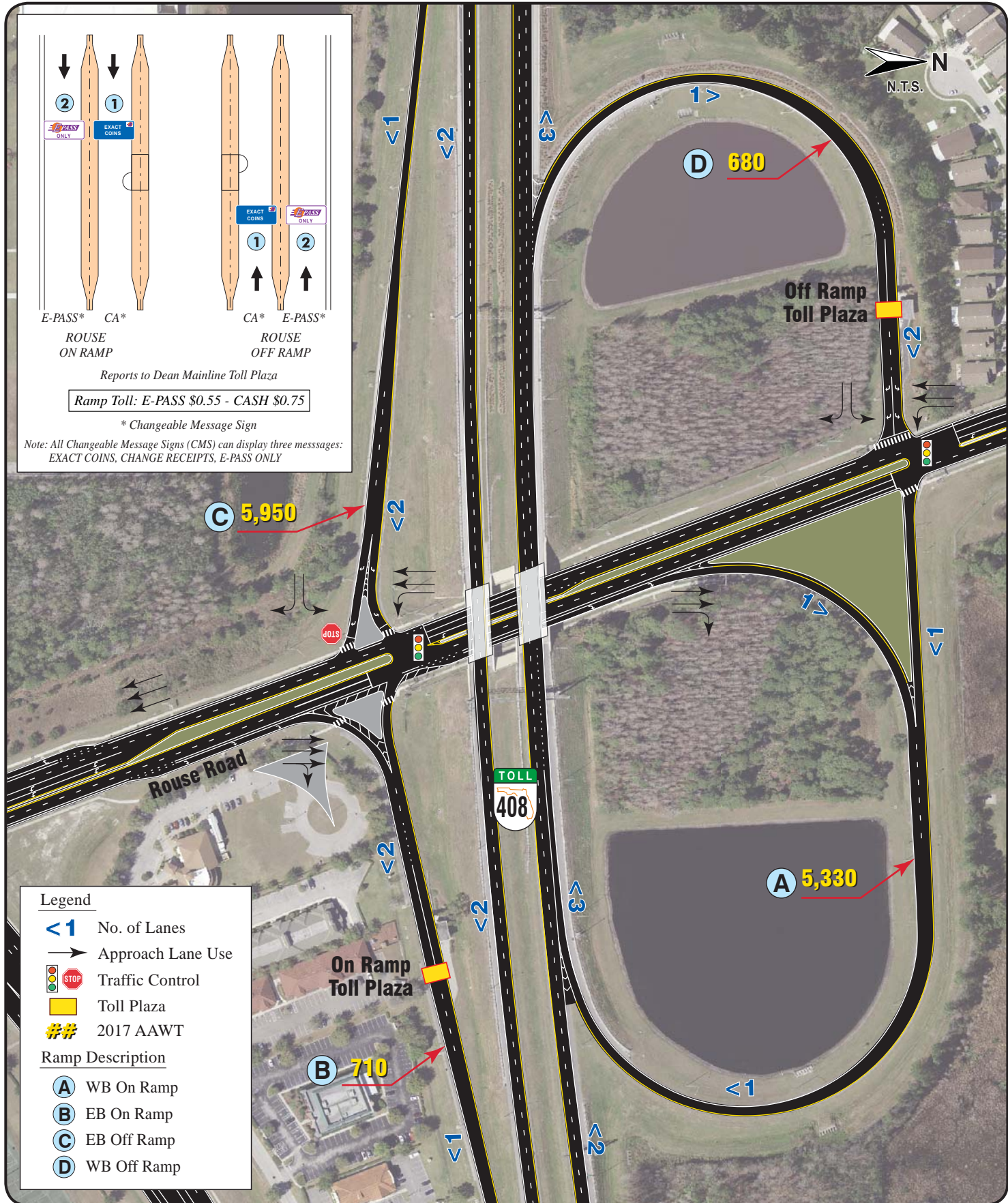
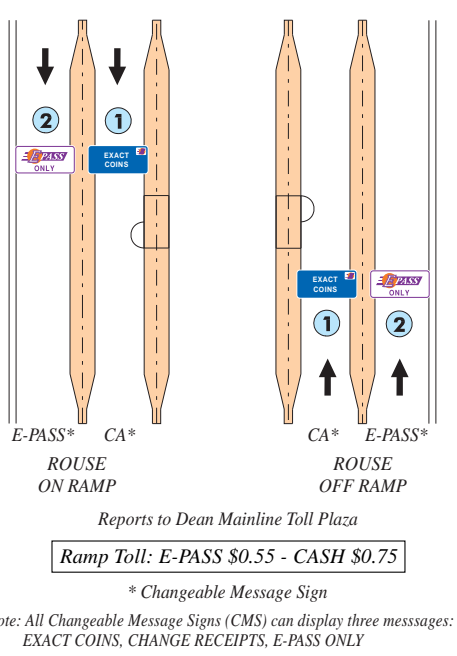

Legend

- <1 No. of Lanes
- ➔ Approach Lane Use
- 🚦 Traffic Control
- 🟡 Toll Plaza
- ## 2017 AAWT

Ramp Description

- (A) WB On Ramp
- (B) EB On Ramp
- (C) EB Off Ramp
- (D) WB Off Ramp

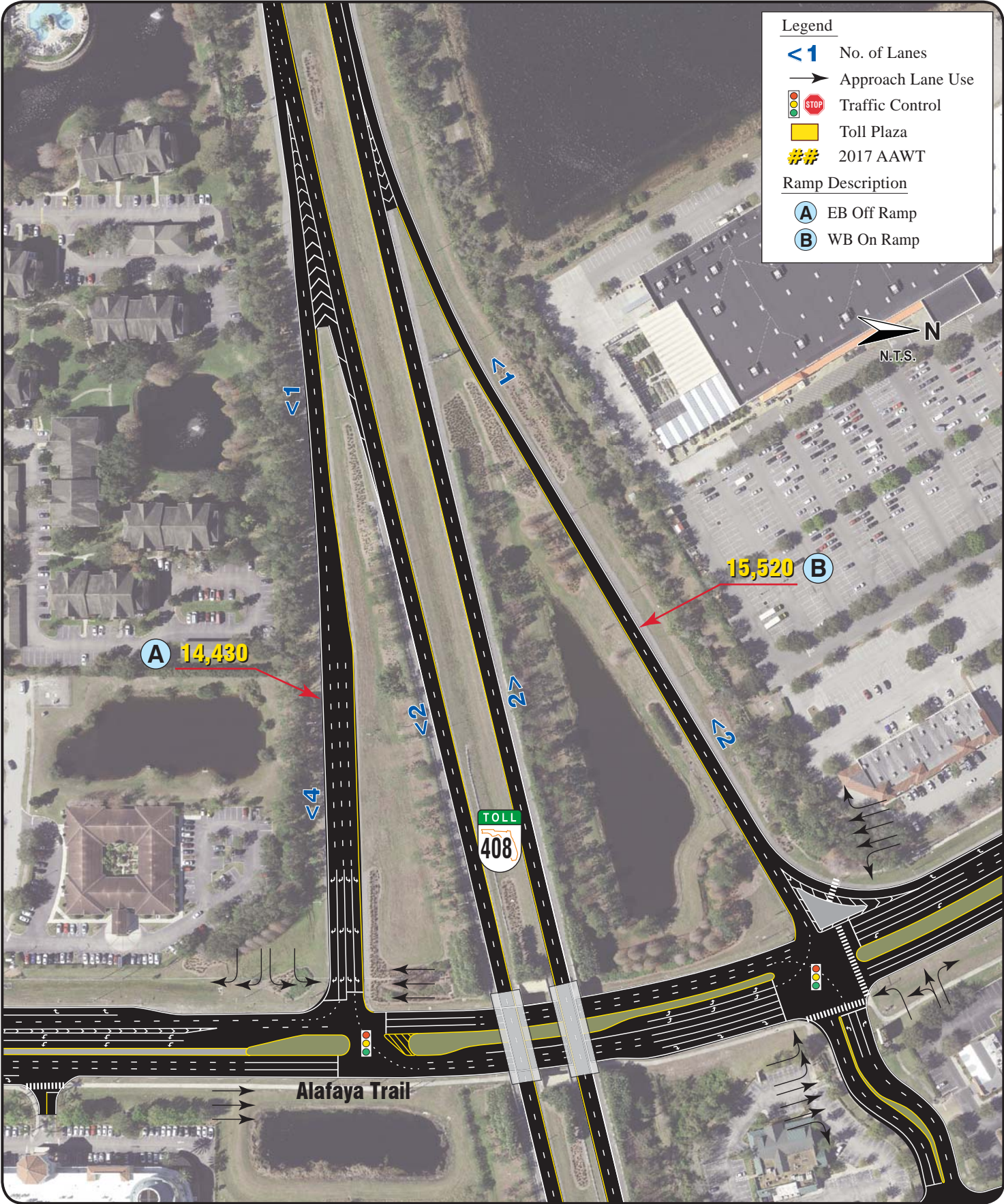

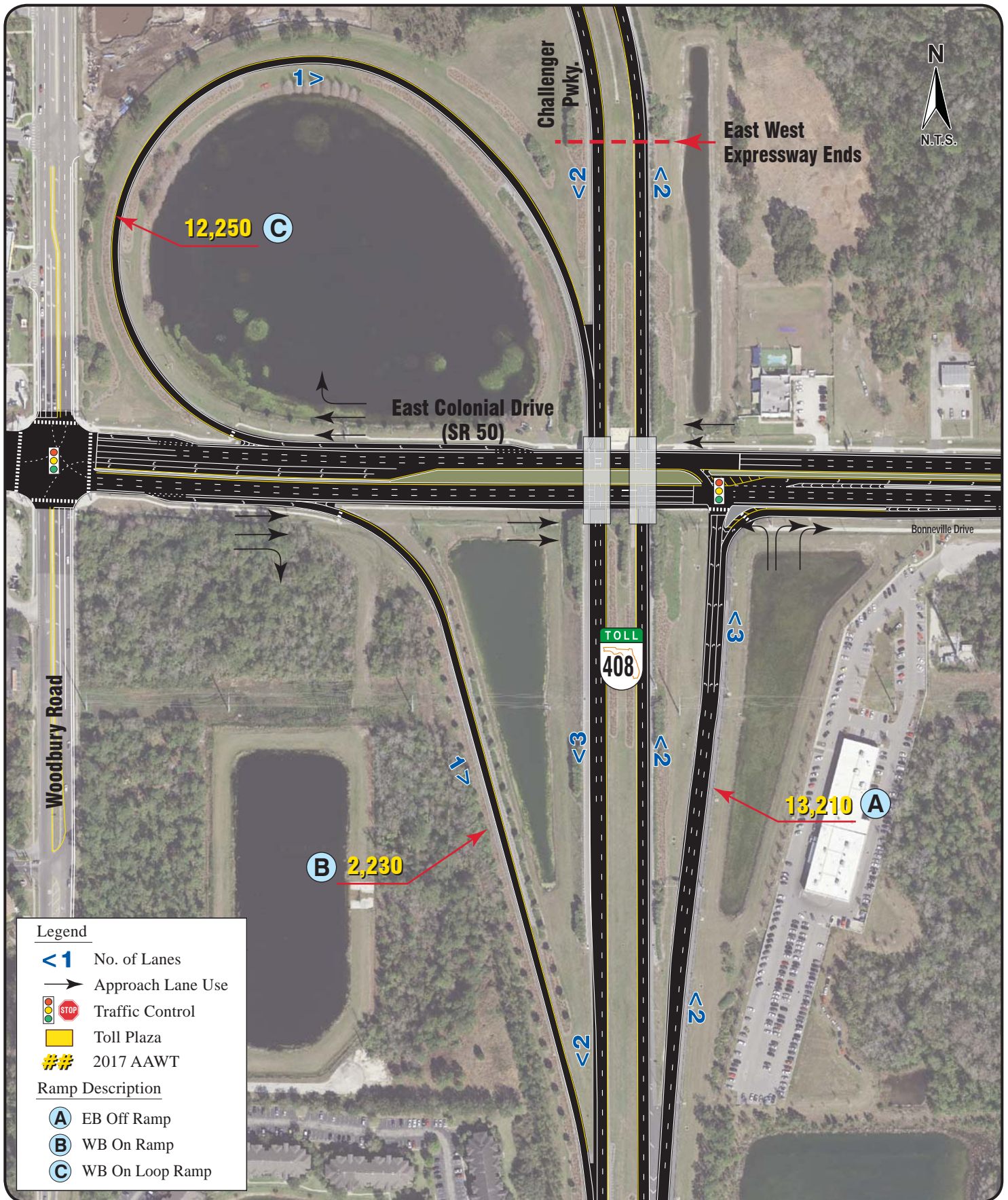

Legend

- <1> No. of Lanes
- Approach Lane Use
- 🚦 STOP Traffic Control
- 🟡 Toll Plaza
- ## 2017 AAWT

Ramp Description

- Ⓐ EB Off Ramp
- Ⓑ WB On Ramp
- Ⓒ WB On Loop Ramp

Beachline Expressway

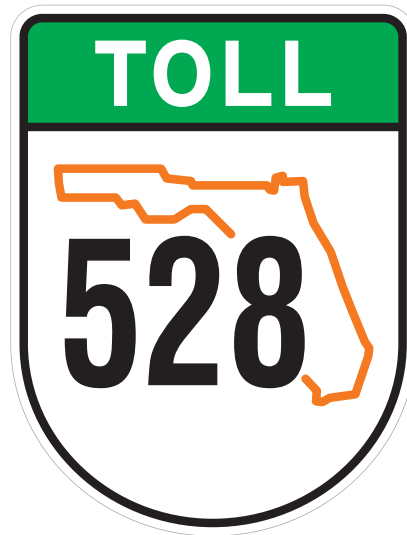

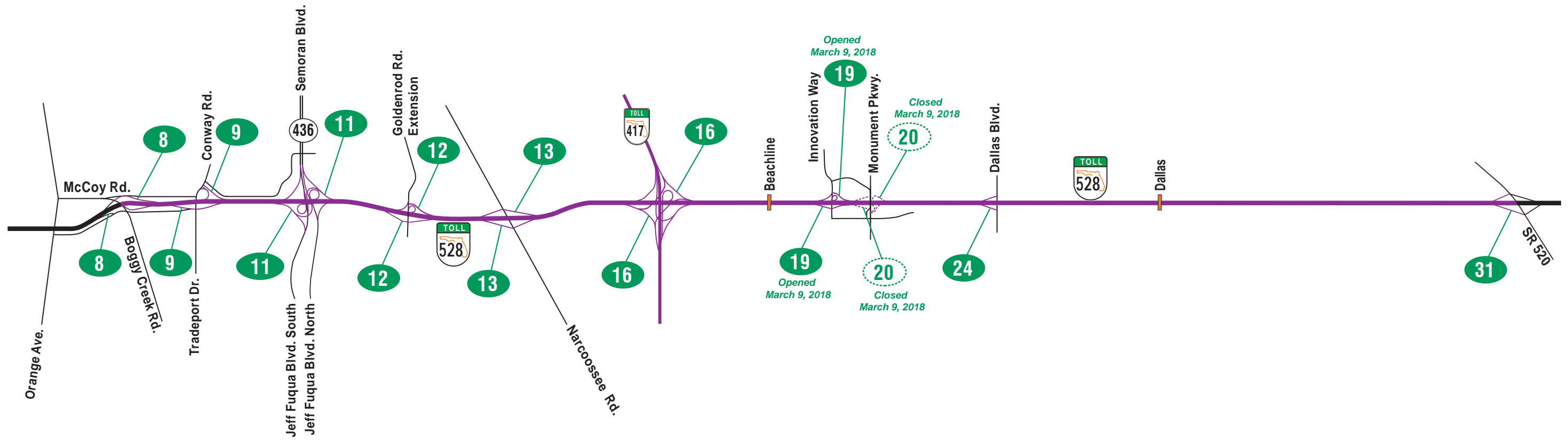

LEGEND

- Exit Number
- Existing SR 528
- Mainline Toll Plaza

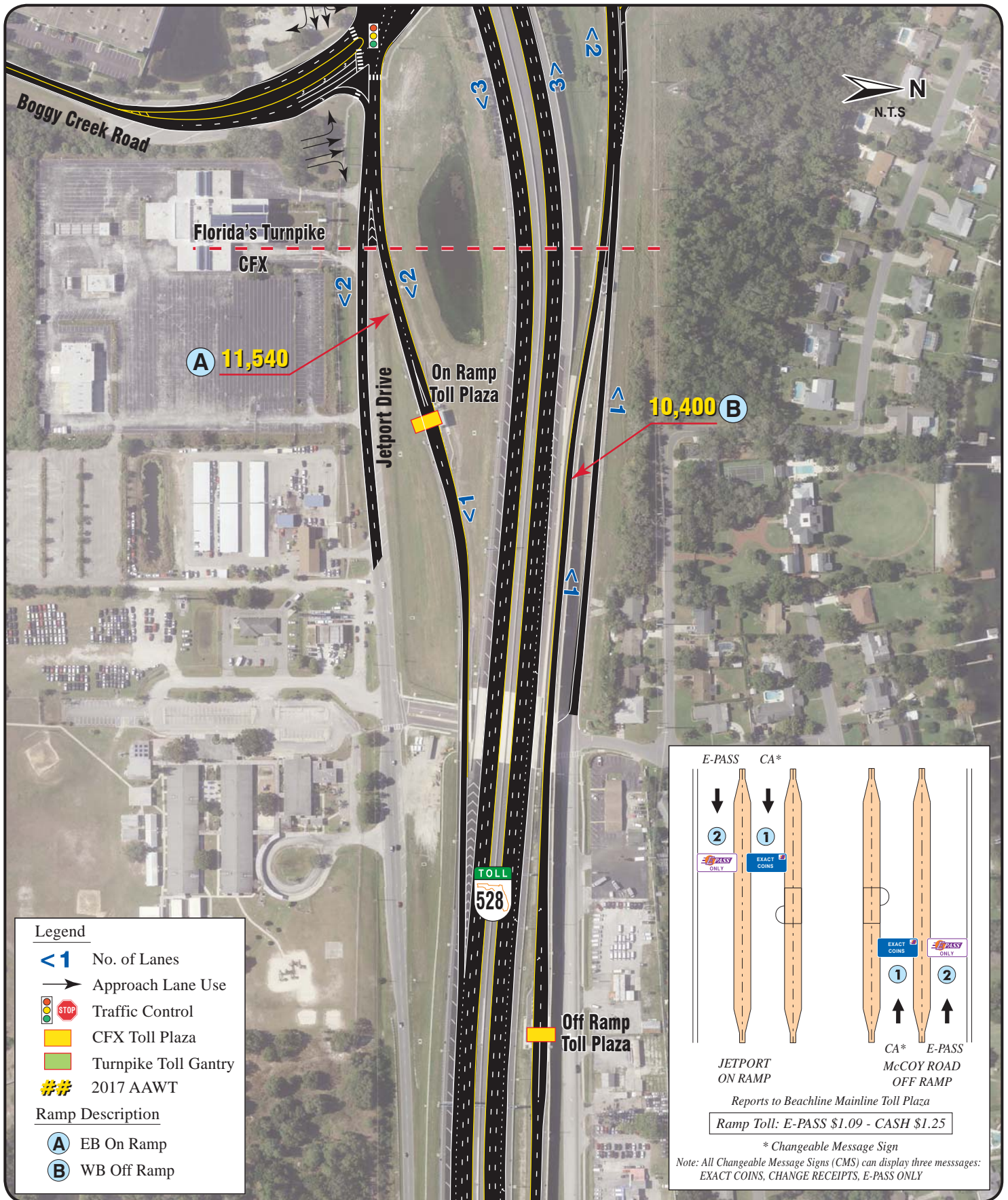

Legend

- <1 No. of Lanes
- Approach Lane Use
- STOP Traffic Control
- CFX Toll Plaza
- Turnpike Toll Gantry
- ## 2017 AAWT

Ramp Description

- (A) EB On Ramp
- (B) WB Off Ramp

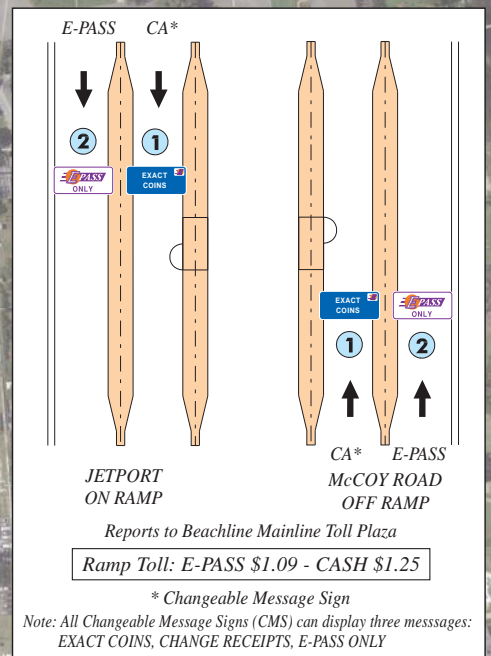

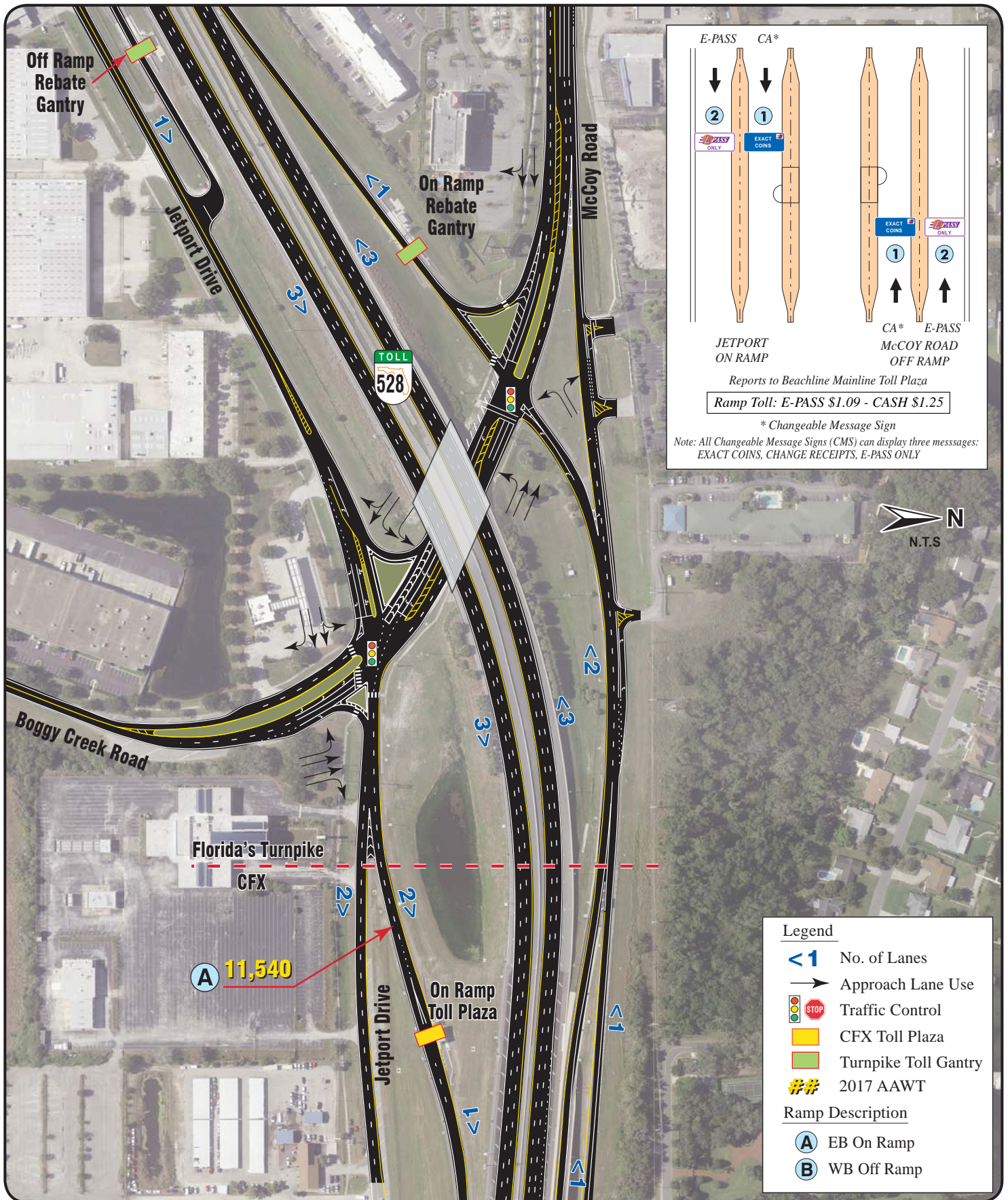

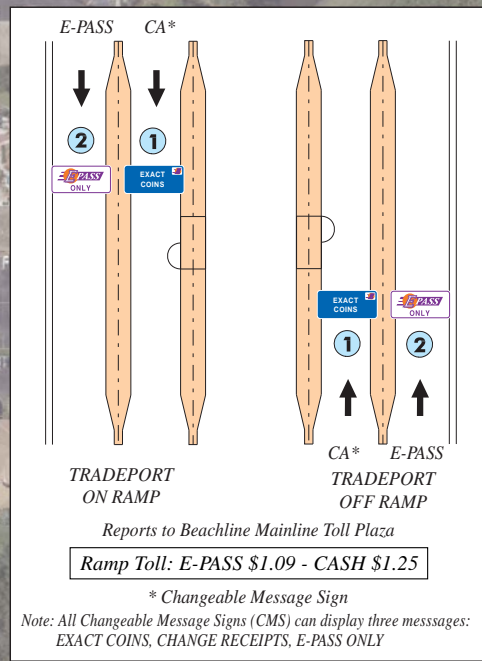
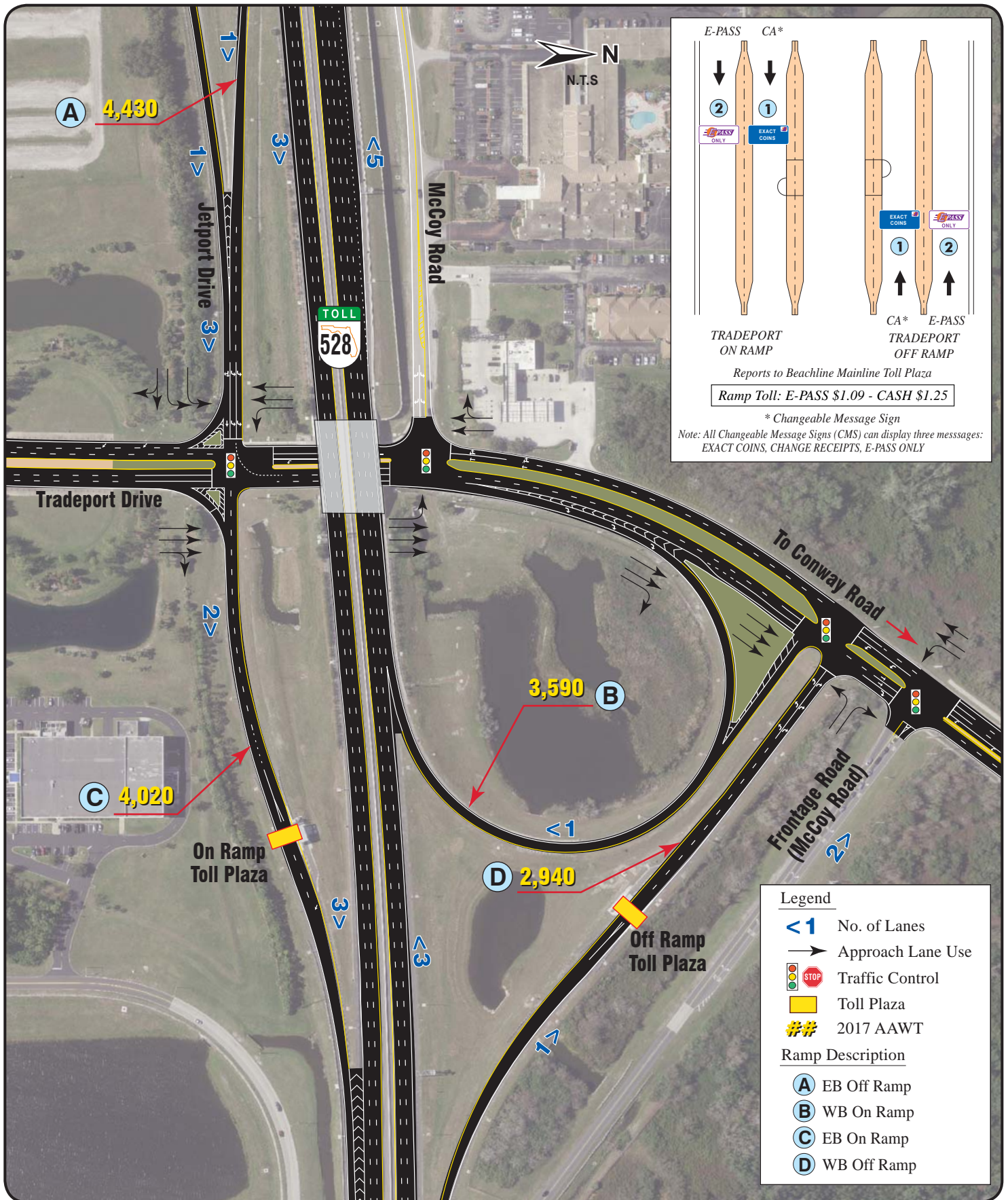

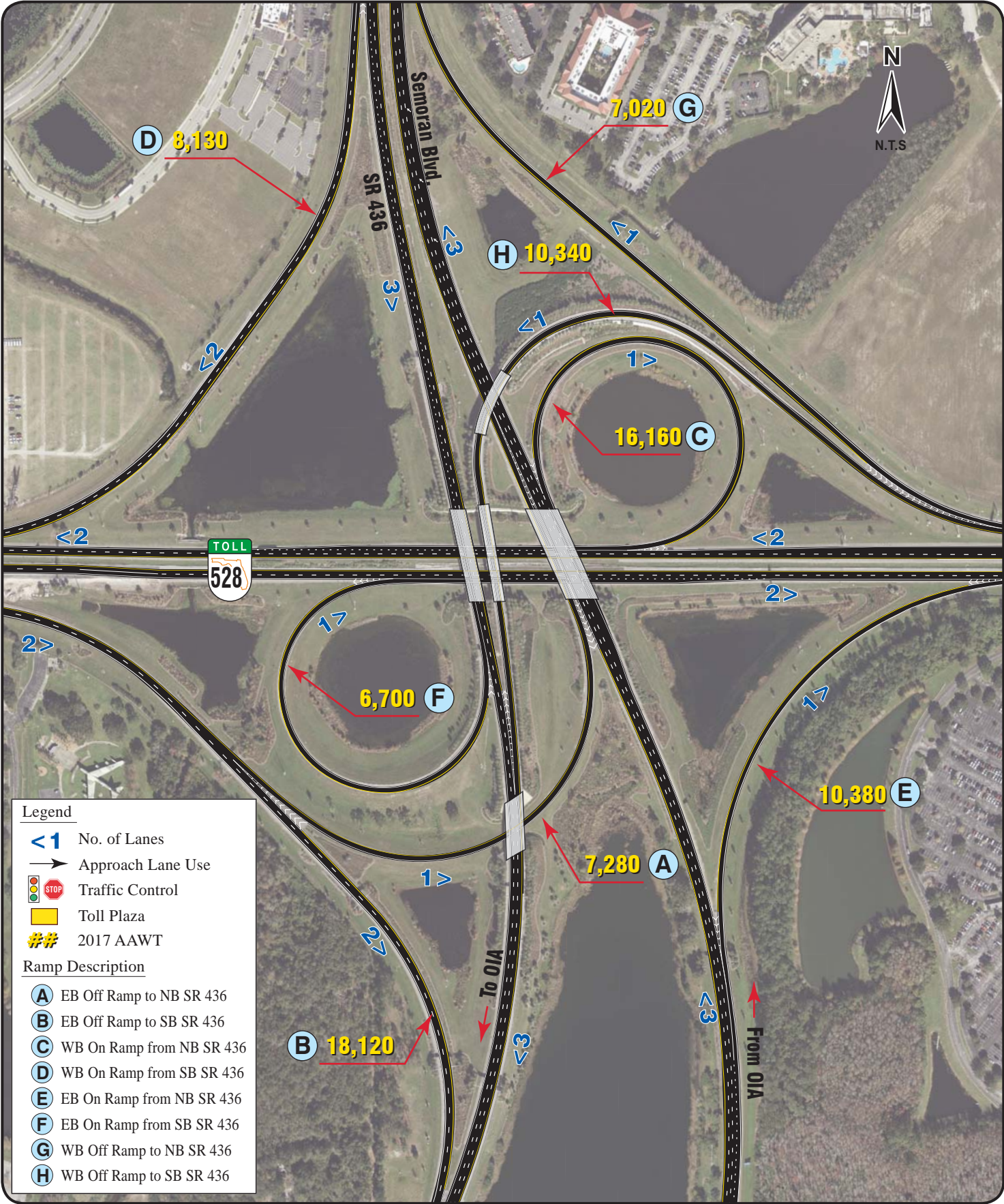

Legend

- <1> No. of Lanes
- Approach Lane Use
- 🚦 STOP Traffic Control
- 🟡 Toll Plaza
- ## 2017 AAWT

Ramp Description

- (A) EB Off Ramp to NB SR 436
- (B) EB Off Ramp to SB SR 436
- (C) WB On Ramp from NB SR 436
- (D) WB On Ramp from SB SR 436
- (E) EB On Ramp from NB SR 436
- (F) EB On Ramp from SB SR 436
- (G) WB Off Ramp to NB SR 436
- (H) WB Off Ramp to SB SR 436





Legend

- <1** No. of Lanes
- Approach Lane Use
- STOP** Traffic Control
- Toll Plaza
- ##** 2017 AAWT

Ramp Description

- A** EB Off Ramp
- B** WB On Ramp from SB Goldenrod
- C** EB On Ramp
- D** WB Off Ramp
- E** WB On Ramp from NB Goldenrod

Legend

- <1 No. of Lanes
- Approach Lane Use
-  Traffic Control
-  Toll Plaza
- ## 2017 AAWT

Ramp Description

- (A)** EB Off Ramp
- (B)** WB On Ramp
- (C)** EB On Ramp
- (D)** WB Off Ramp

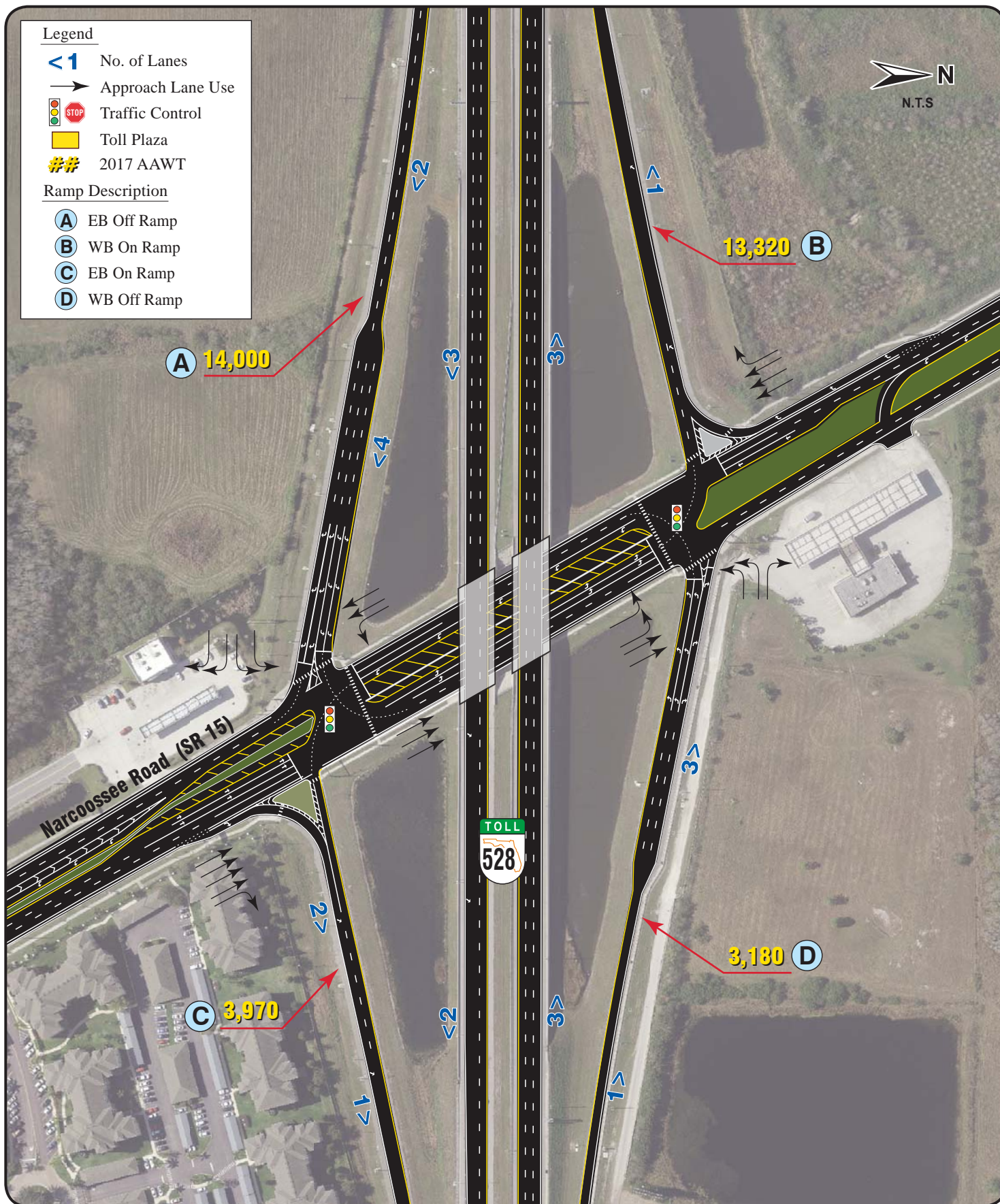

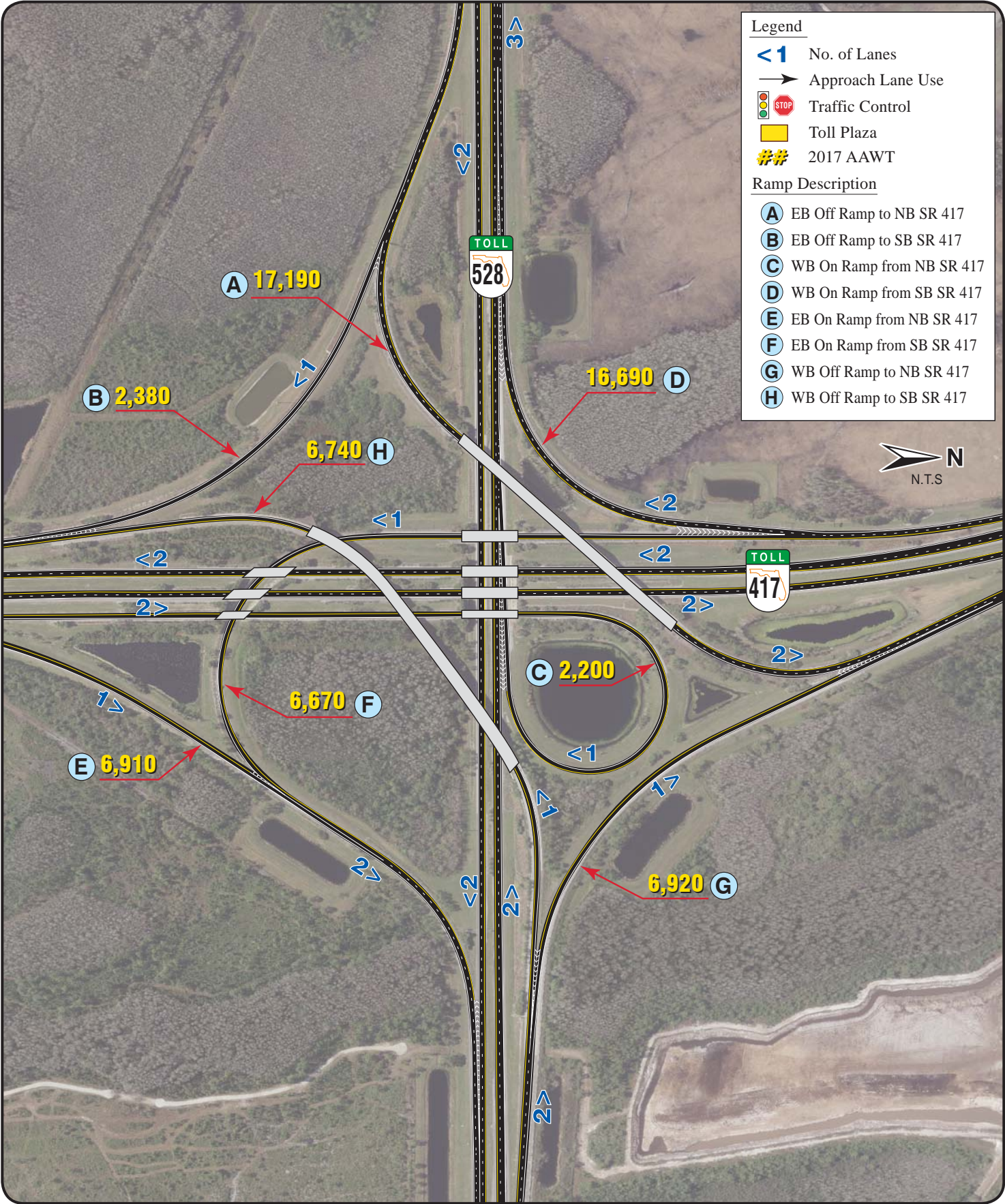

Legend



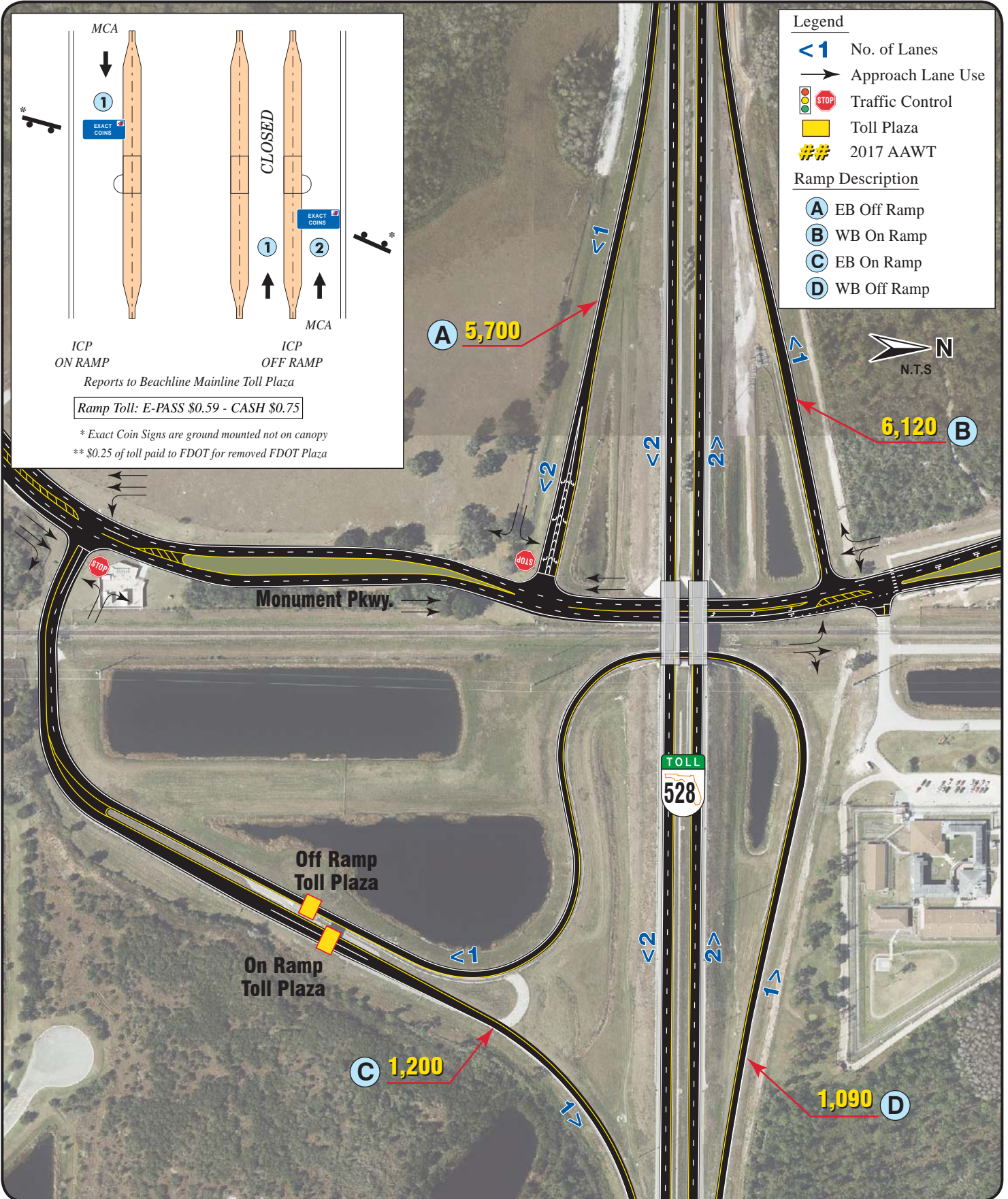
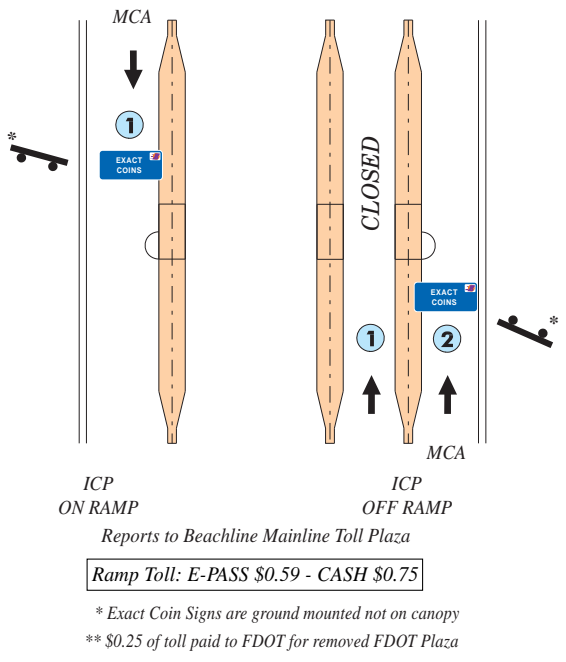

- <1 No. of Lanes
- Approach Lane Use
- STOP Traffic Control
- Yellow Box Toll Plaza
- ## 2017 AAWT

Ramp Description



- (A) EB Off Ramp
- (B) WB On Ramp
- (C) EB On Ramp
- (D) WB Off Ramp



Legend

-  No. of Lanes
-  Approach Lane Use
-  Traffic Control
-  Toll Plaza
-  2017 AAWT

Ramp Description

-  EB Off Ramp
-  WB On Ramp

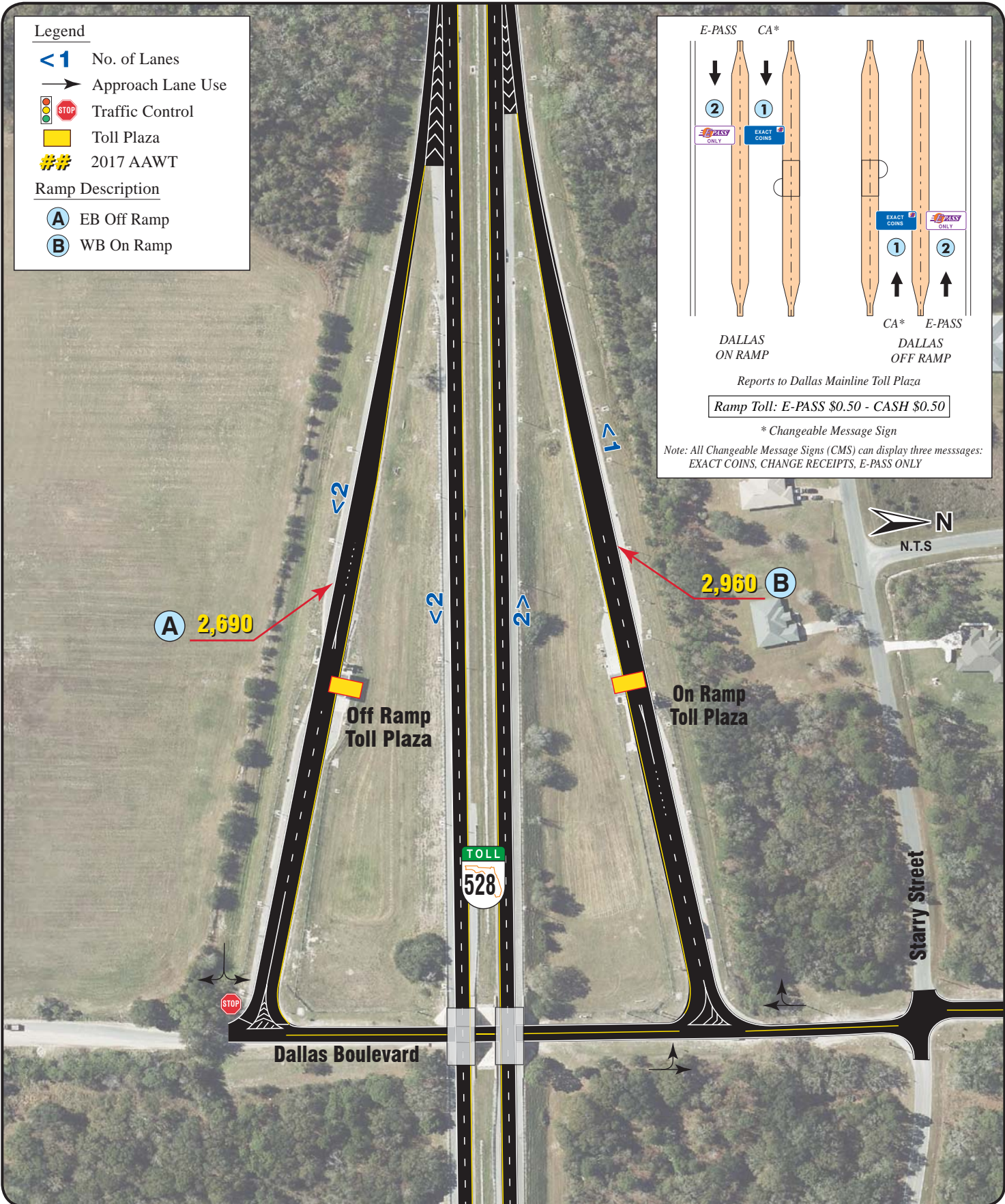
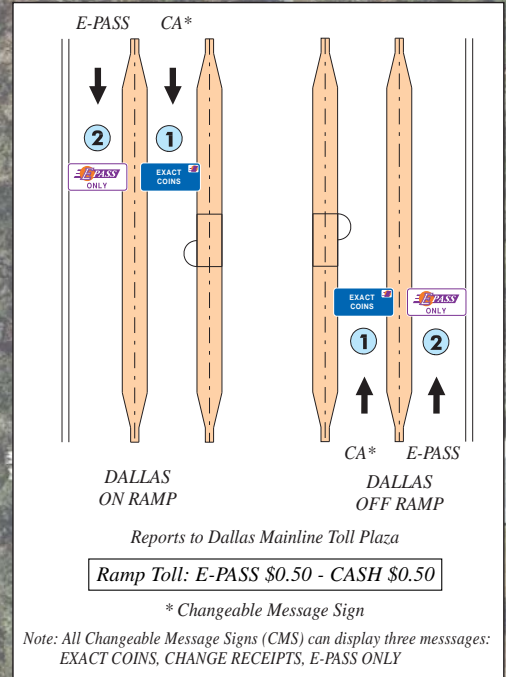

Legend

- <1 No. of Lanes
- Approach Lane Use
- ⏸ STOP Traffic Control
- Toll Plaza
- ## 2017 AAWT

Ramp Description

- (A) EB Off Ramp
- (B) WB On Ramp

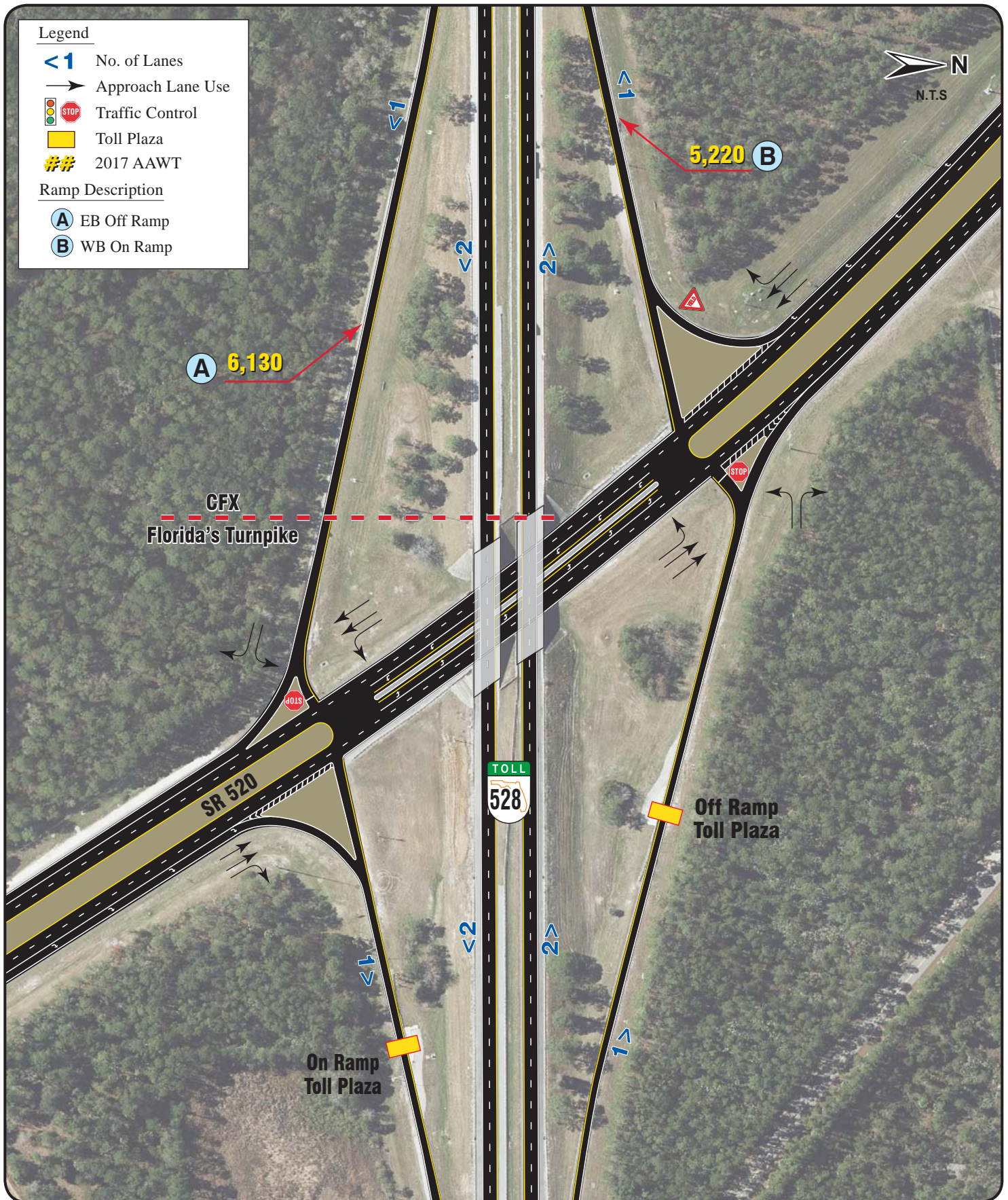

Central Florida GreeneWay



2017 Traffic Data and Statistics Manual
CENTRAL FLORIDA EXPRESSWAY AUTHORITY



LEGEND

- Exit Number
- Existing SR 417
- Mainline Toll Plaza



SR 417 - CENTRAL FLORIDA GREENEWAY Exit Numbers

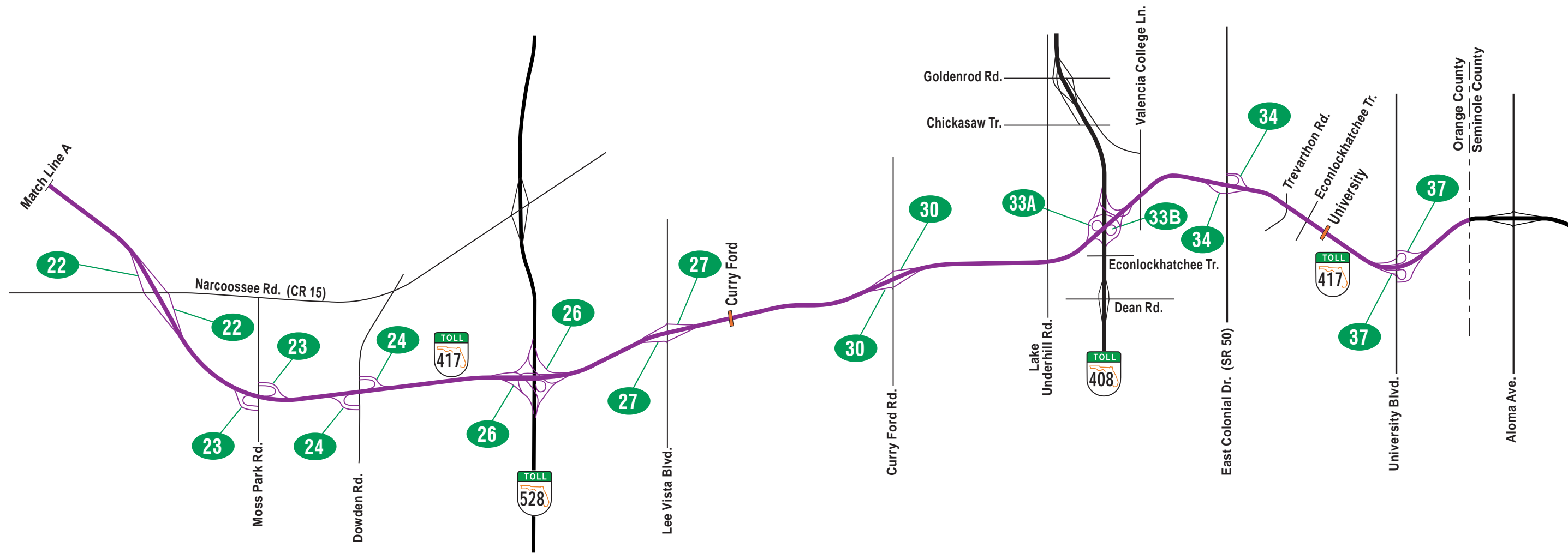

LEGEND

- Exit Number
- Existing SR 417
- Mainline Toll Plaza



SR 417 - CENTRAL FLORIDA GREENEWAY
Exit Numbers



Legend

- <1 No. of Lanes
- Approach Lane Use
- Traffic Control
- Toll Plaza
- 2017 AAWT

Ramp Description

- (A) NB SR 417
- (B) SB SR 417
- (C) NB On Ramp
- (D) SB Off Ramp

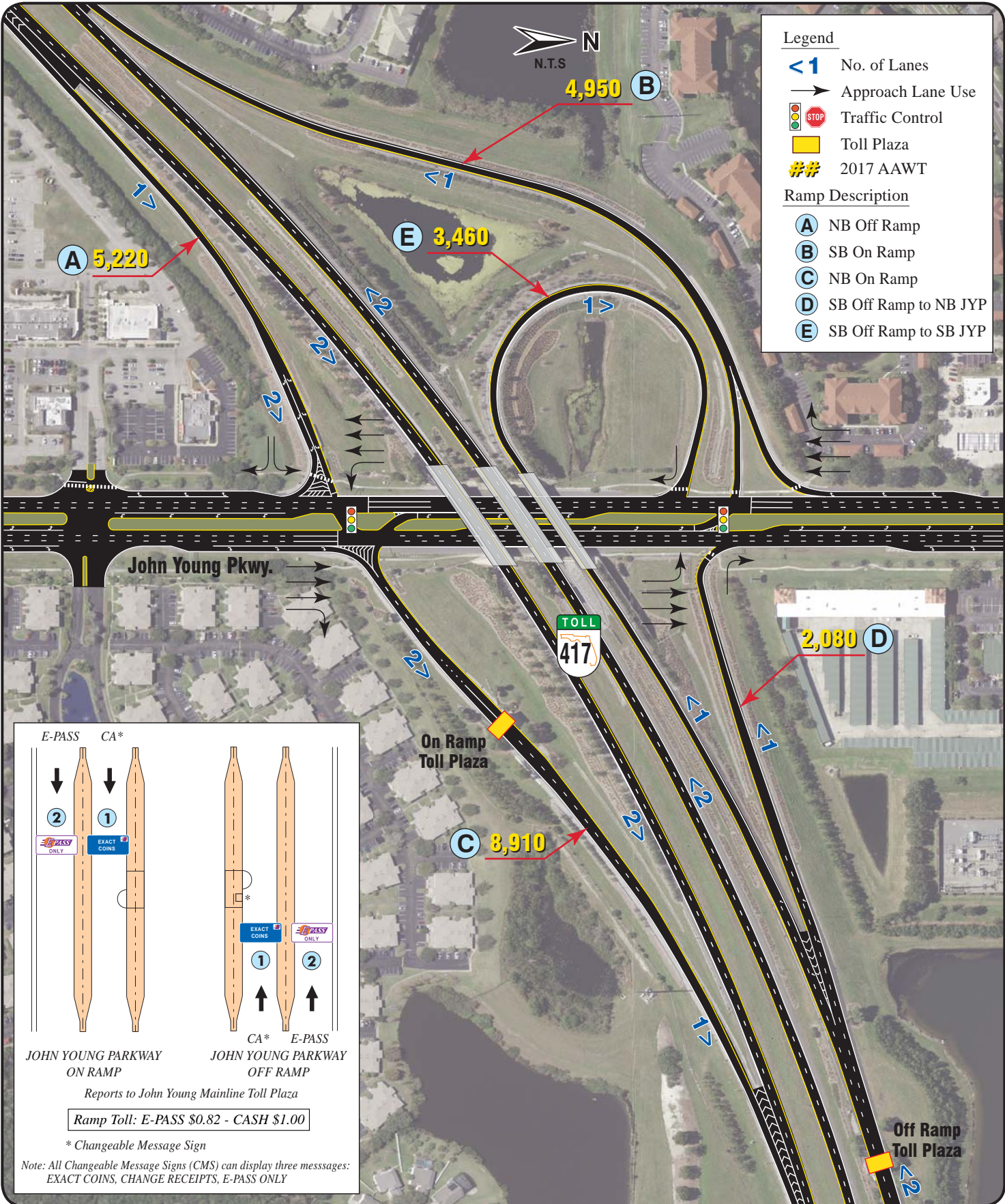

Legend

- <1> No. of Lanes
- Approach Lane Use
- 🚦 STOP Traffic Control
- 🟡 Toll Plaza
- ## 2017 AAWT

Ramp Description

- (A) NB Off Ramp
- (B) SB On Ramp
- (C) NB On Ramp
- (D) SB Off Ramp to NB JYP
- (E) SB Off Ramp to SB JYP

E-PASS CA*

JOHN YOUNG PARKWAY ON RAMP

JOHN YOUNG PARKWAY OFF RAMP

Reports to John Young Mainline Toll Plaza

Ramp Toll: E-PASS \$0.82 - CASH \$1.00

* Changeable Message Sign

Note: All Changeable Message Signs (CMS) can display three messages: EXACT COINS, CHANGE RECEIPTS, E-PASS ONLY



SR 417 (CENTRAL FLORIDA GREENEWAY)
Exit 10 - John Young Parkway

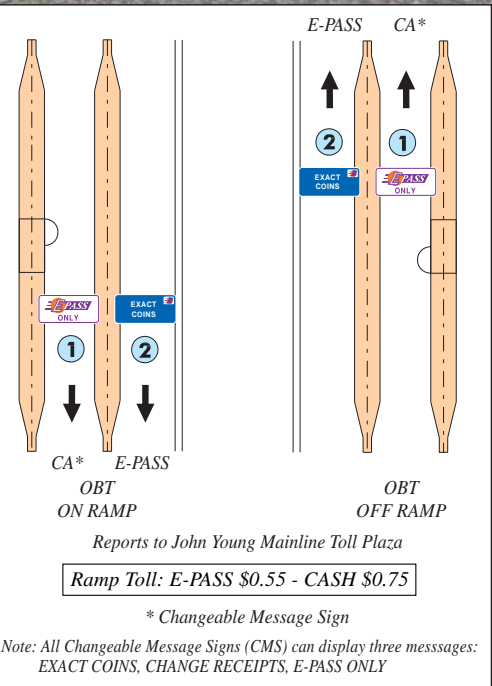
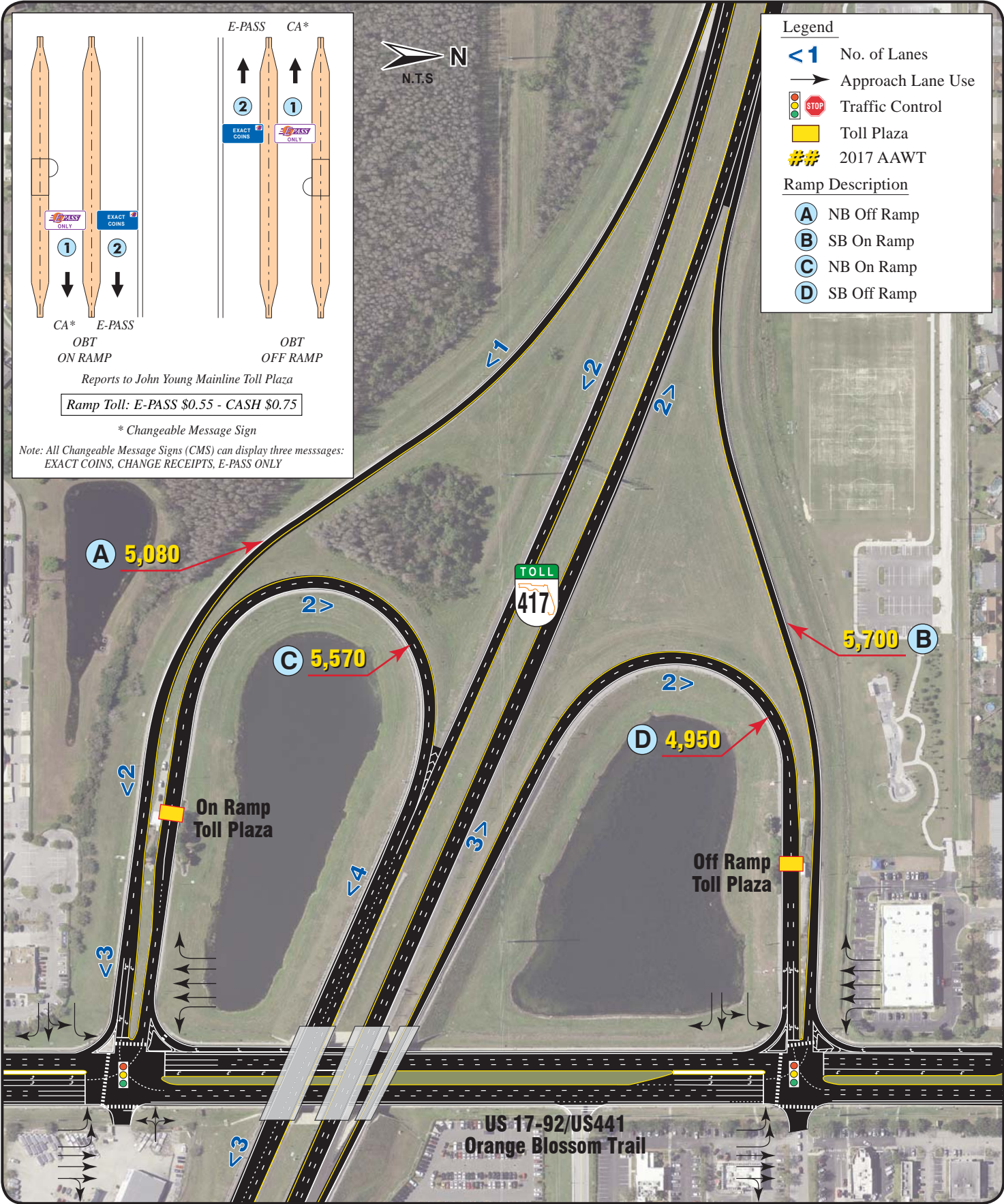

Legend

- <1 No. of Lanes
- Approach Lane Use
- STOP Traffic Control
- Yellow Box Toll Plaza
- ## 2017 AAWT

Ramp Description

- (A) NB Off Ramp
- (B) SB On Ramp
- (C) NB On Ramp
- (D) SB Off Ramp



Legend

- <1> No. of Lanes
- Approach Lane Use
- Traffic Control
- Toll Plaza
- ## 2017 AAWT

Ramp Description

- A** SB Off Ramp to SB Turnpike
- B** NB On Ramp from NB Turnpike
- C** SB Off Ramp to NB Turnpike
- D** NB Off Ramp to SB Turnpike
- E** NB Off Ramp to NB Turnpike

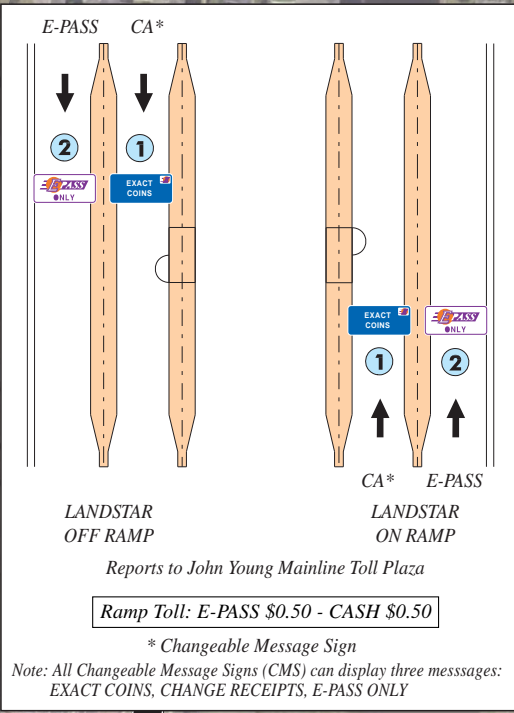
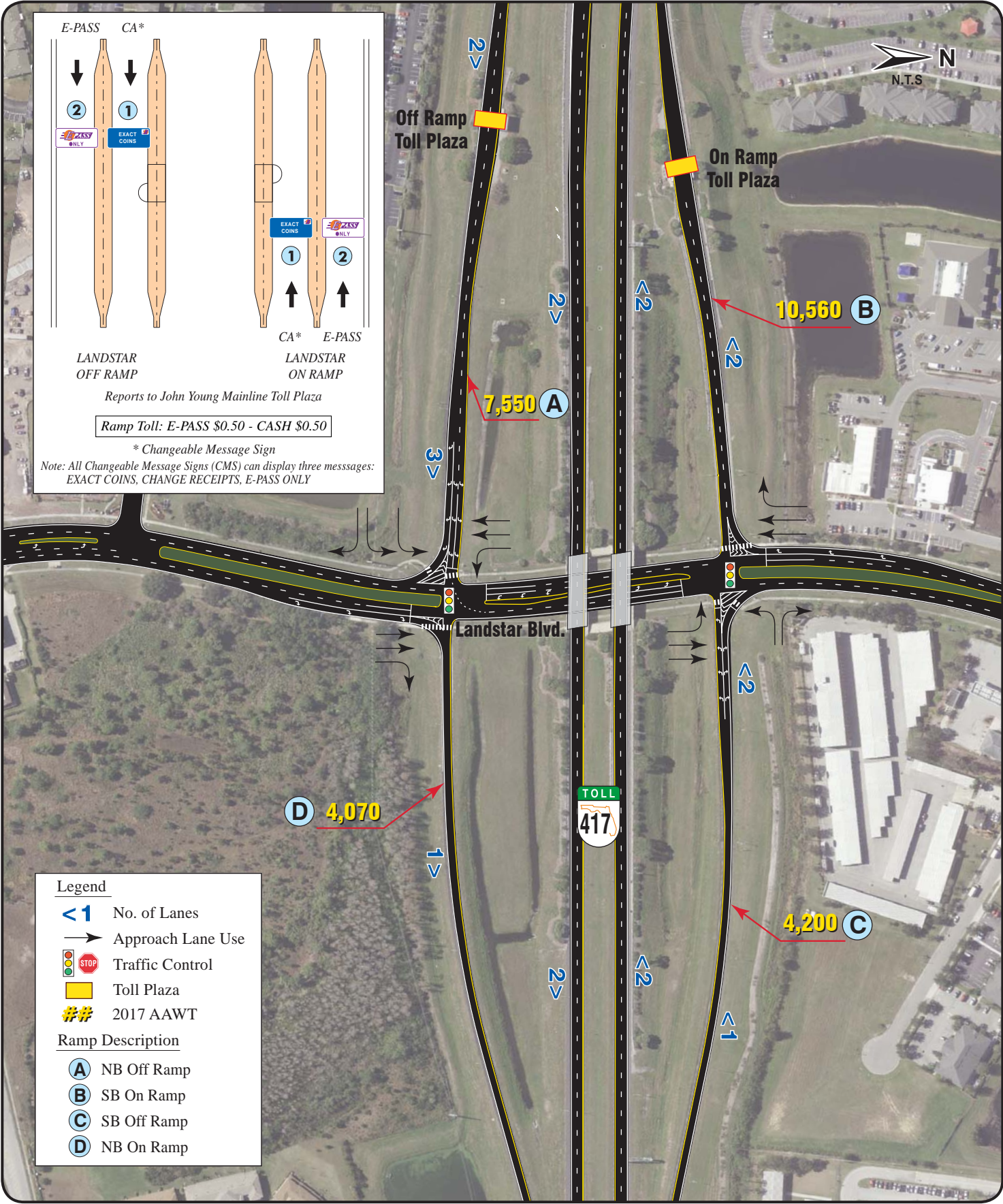

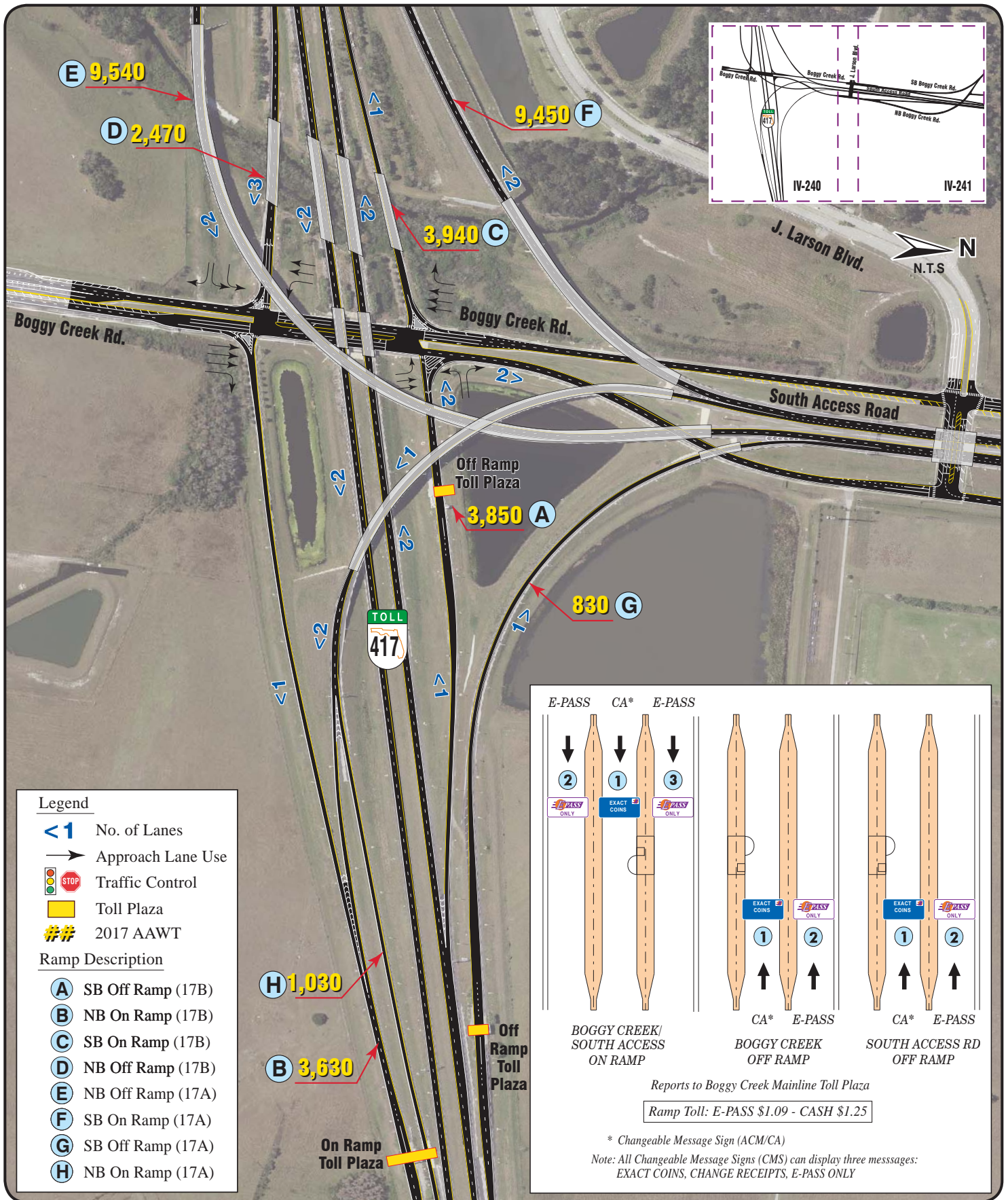

- Legend**
- <1 No. of Lanes
 - ➔ Approach Lane Use
 - 🚦 Traffic Control
 - 🟡 Toll Plaza
 - ## 2017 AAWT
- Ramp Description**
- A** SB Off Ramp (17B)
 - B** NB On Ramp (17B)
 - C** SB On Ramp (17B)
 - D** NB Off Ramp (17B)
 - E** NB Off Ramp (17A)
 - F** SB On Ramp (17A)
 - G** SB Off Ramp (17A)
 - H** NB On Ramp (17A)

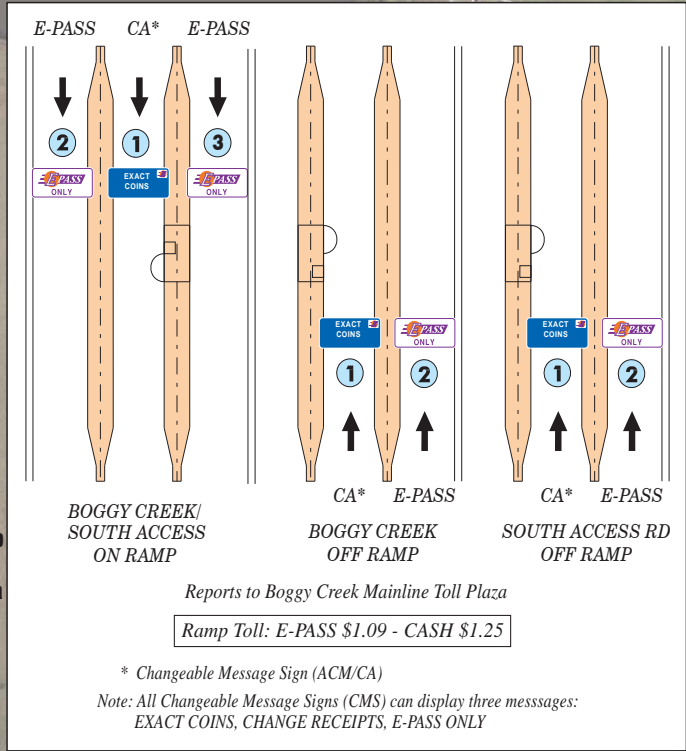

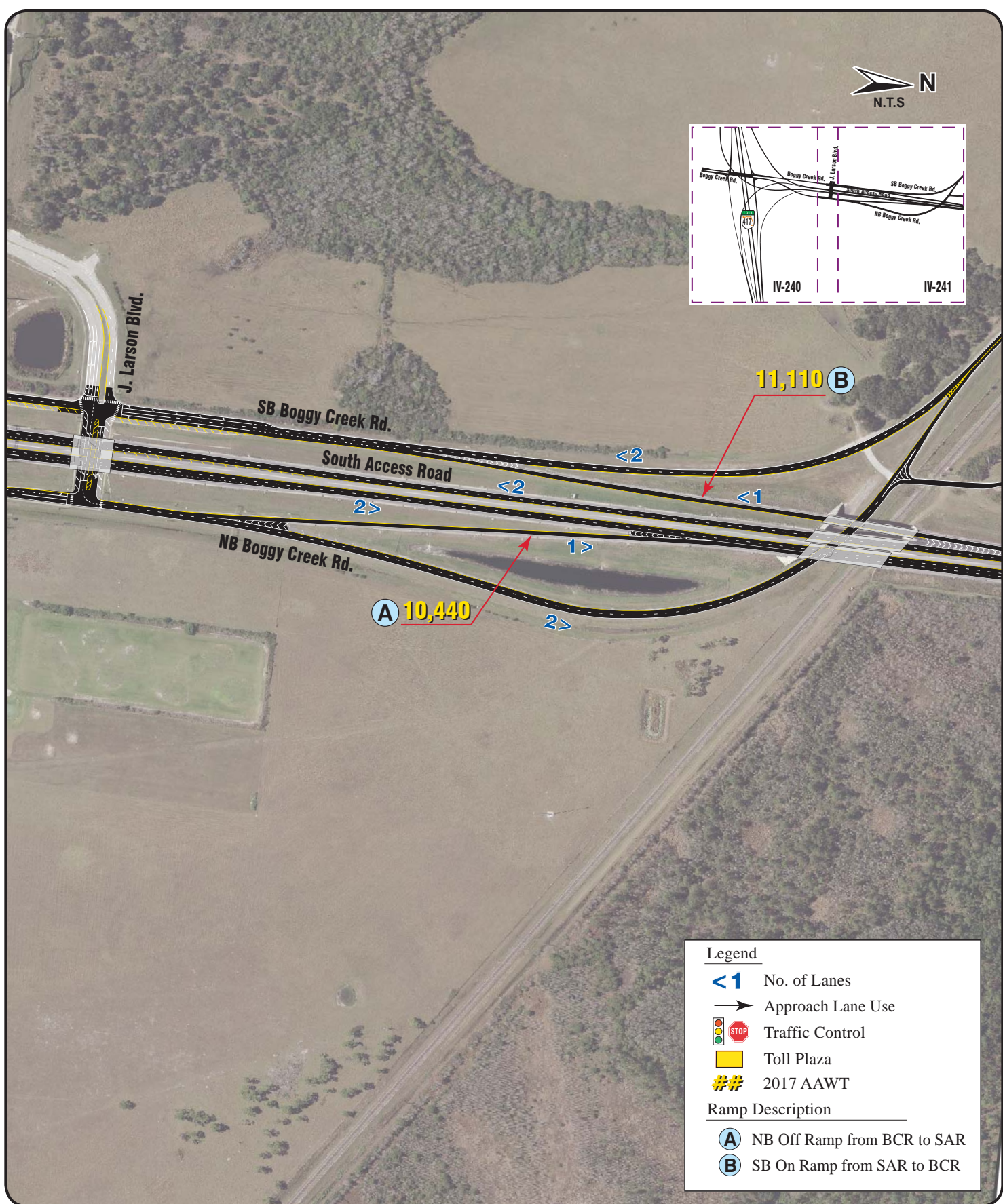
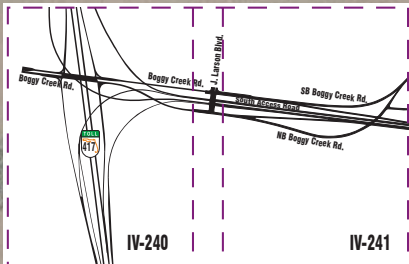

Legend

- <1** No. of Lanes
- Approach Lane Use
- STOP** Traffic Control
- Toll Plaza
- ##** 2017 AAWT

Ramp Description

- (A)** NB Off Ramp from BCR to SAR
- (B)** SB On Ramp from SAR to BCR



SR 417 (CENTRAL FLORIDA GREENEWAY)
Exit 17A&B - Bogy Creek Road and South Access Road (2)

SECTION IV

241

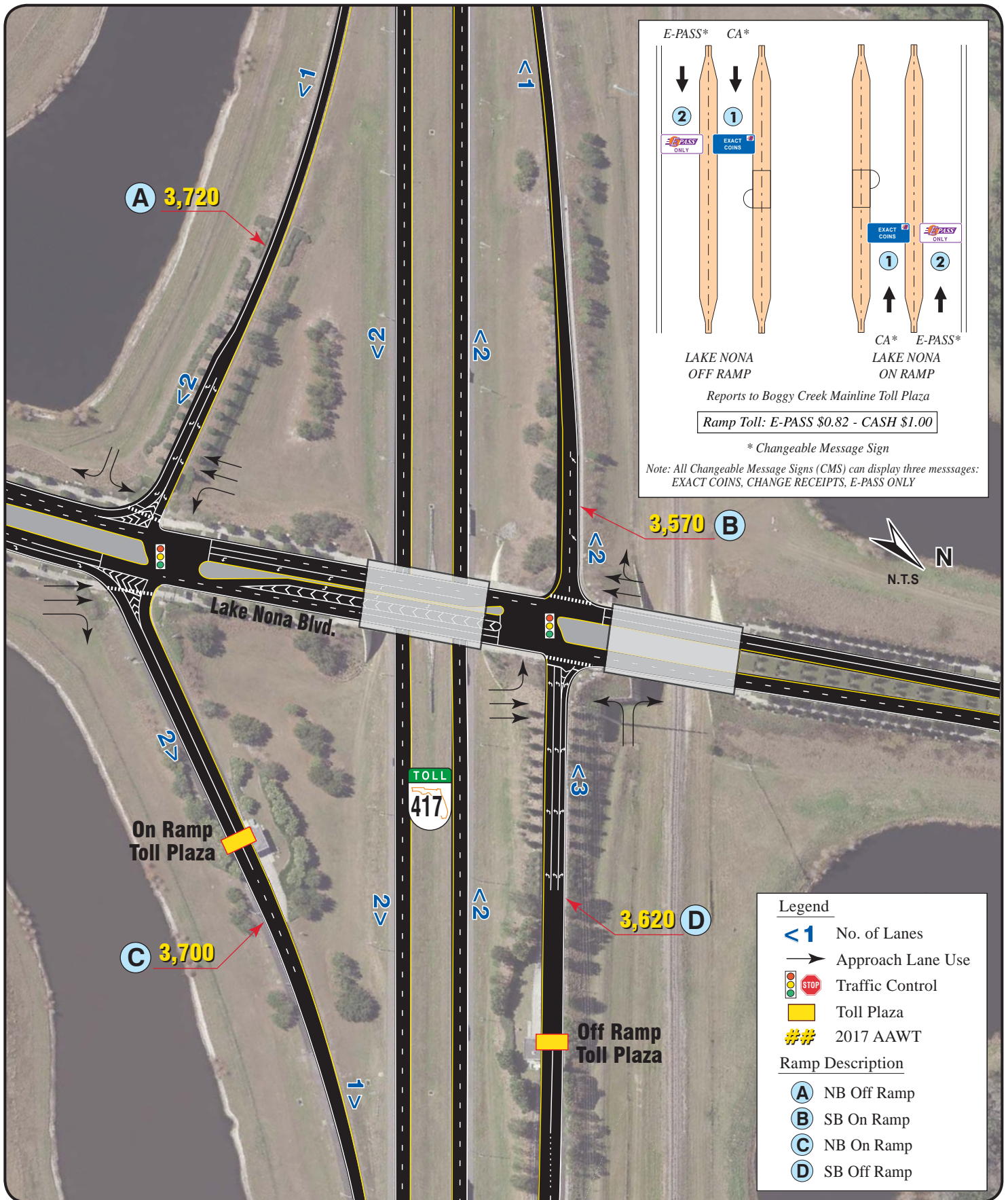

Legend

- No. of Lanes
- Approach Lane Use
- Traffic Control
- Toll Plaza
- 2017 AAWT

Ramp Description

- (A)** NB Off Ramp
- (B)** SB On Ramp
- (C)** NB On Ramp
- (D)** SB Off Ramp

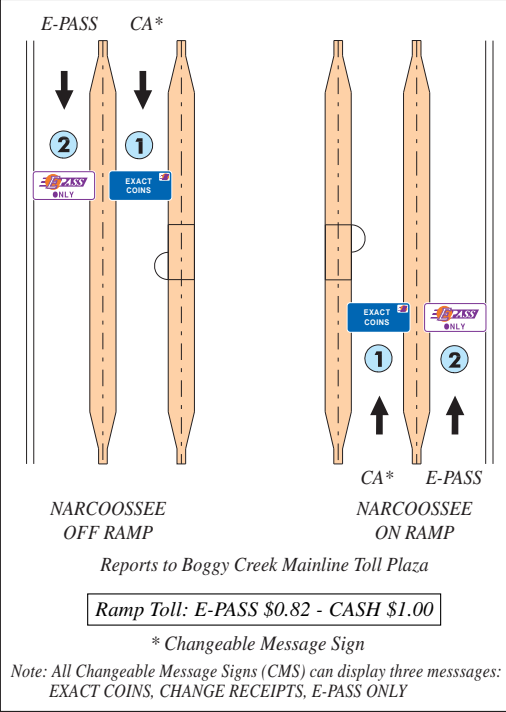
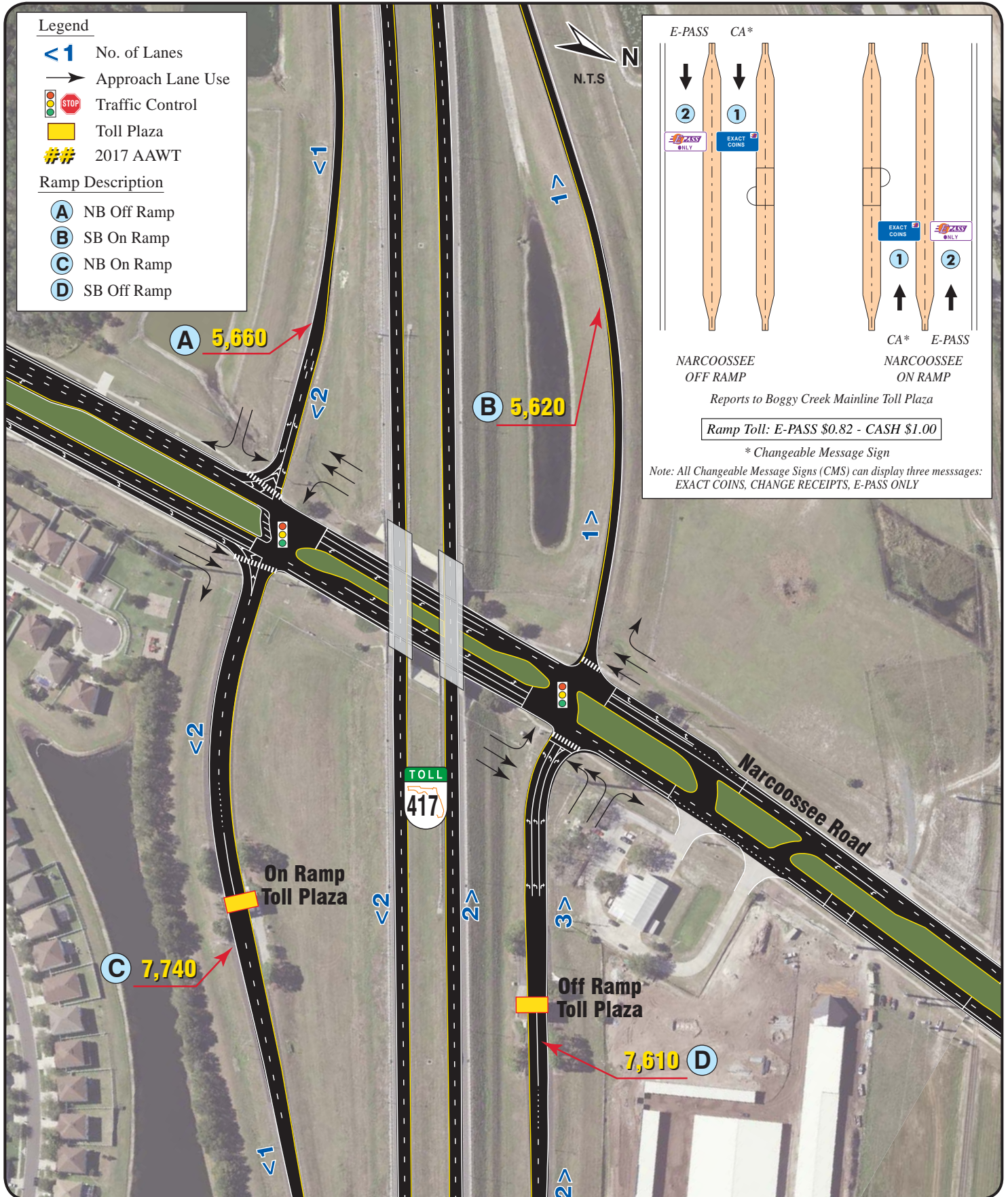

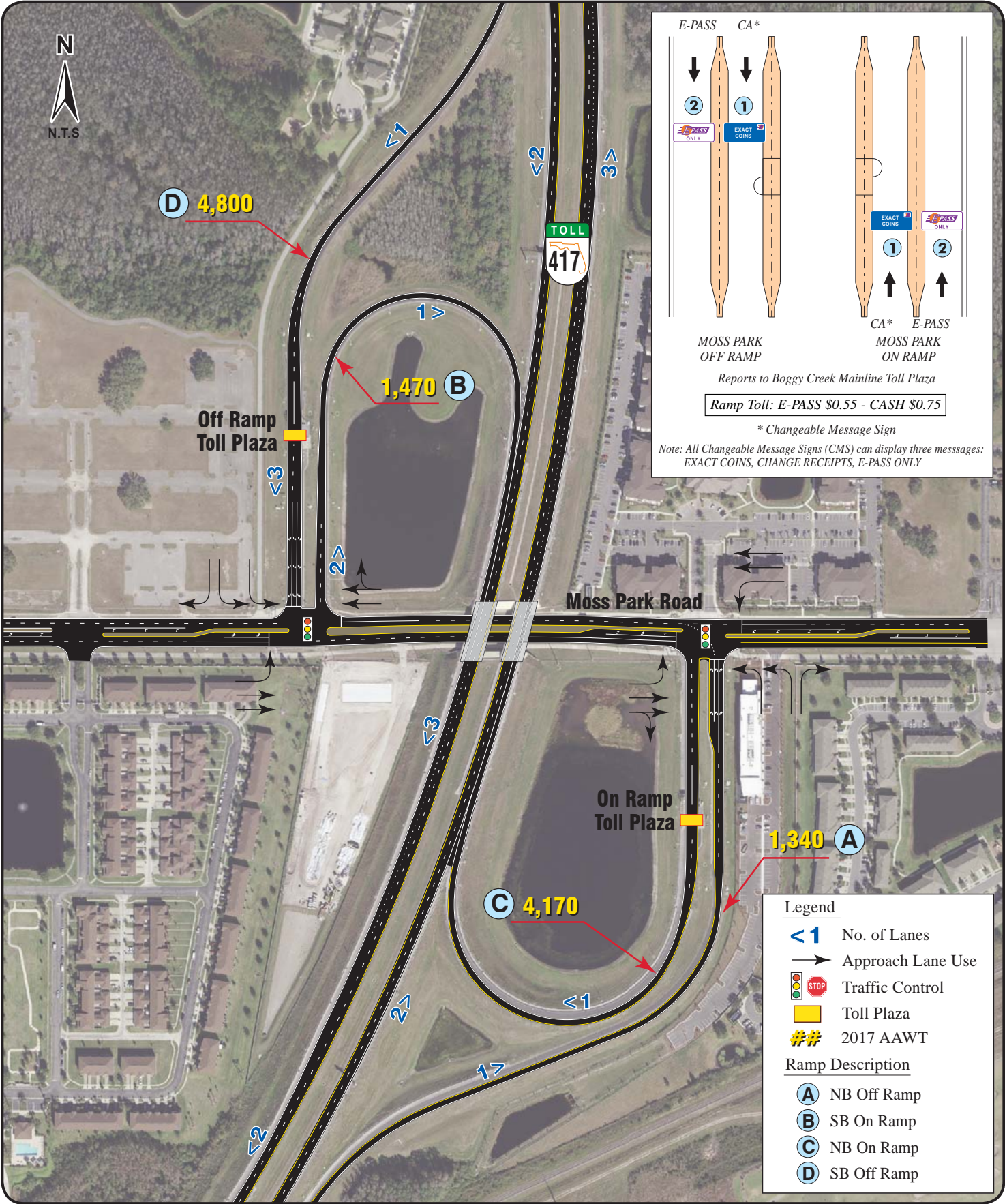

E-PASS CA*

MOSS PARK OFF RAMP

MOSS PARK ON RAMP

Reports to Boggy Creek Mainline Toll Plaza

Ramp Toll: E-PASS \$0.55 - CASH \$0.75

* Changeable Message Sign

Note: All Changeable Message Signs (CMS) can display three messages: EXACT COINS, CHANGE RECEIPTS, E-PASS ONLY

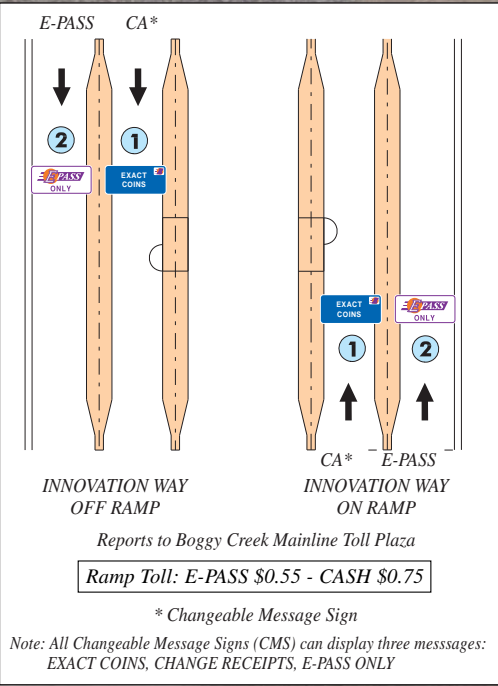
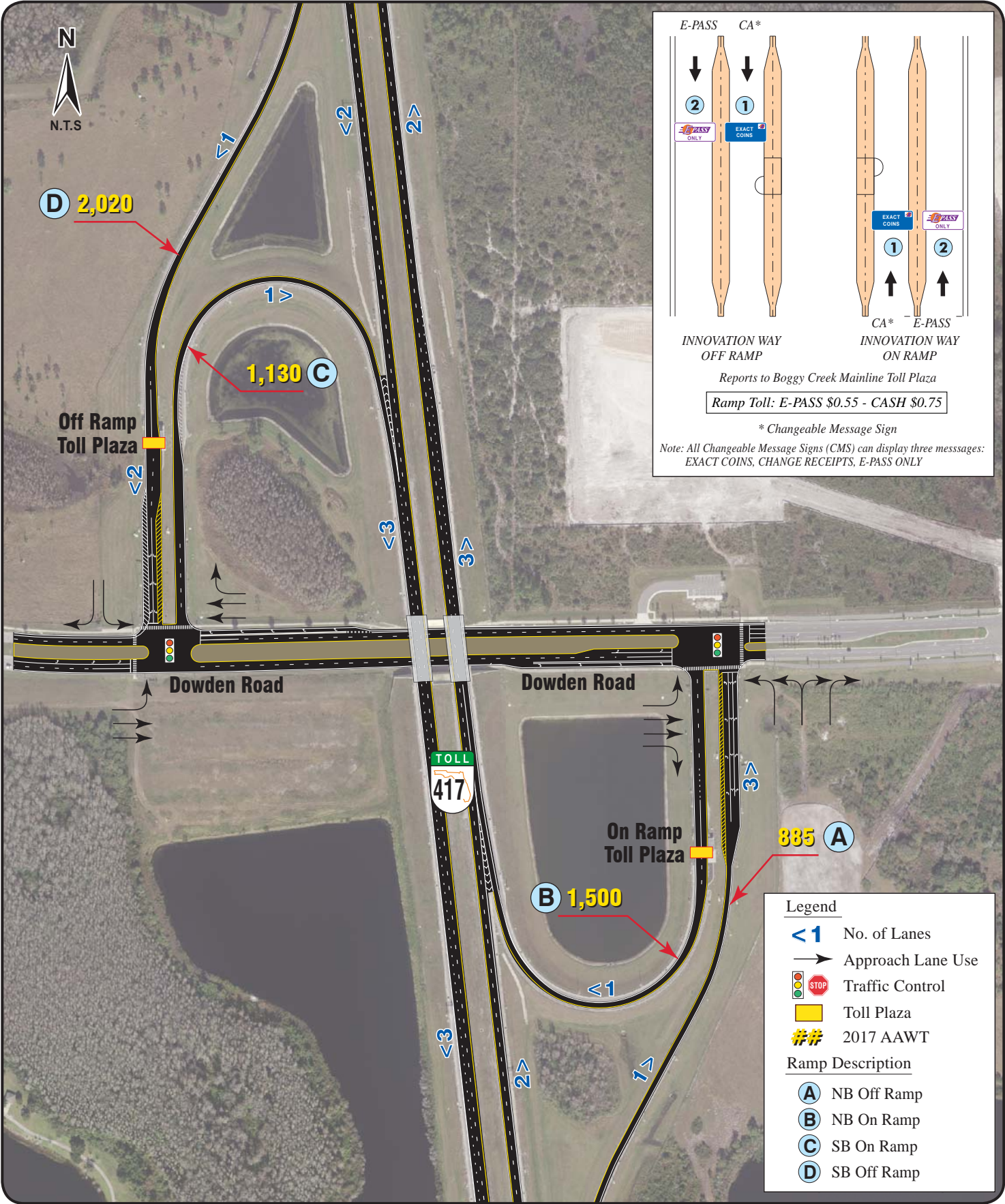

Legend



- <1 No. of Lanes
- Approach Lane Use
- Traffic Control
- Toll Plaza
- ## 2017 AAWT

Ramp Description

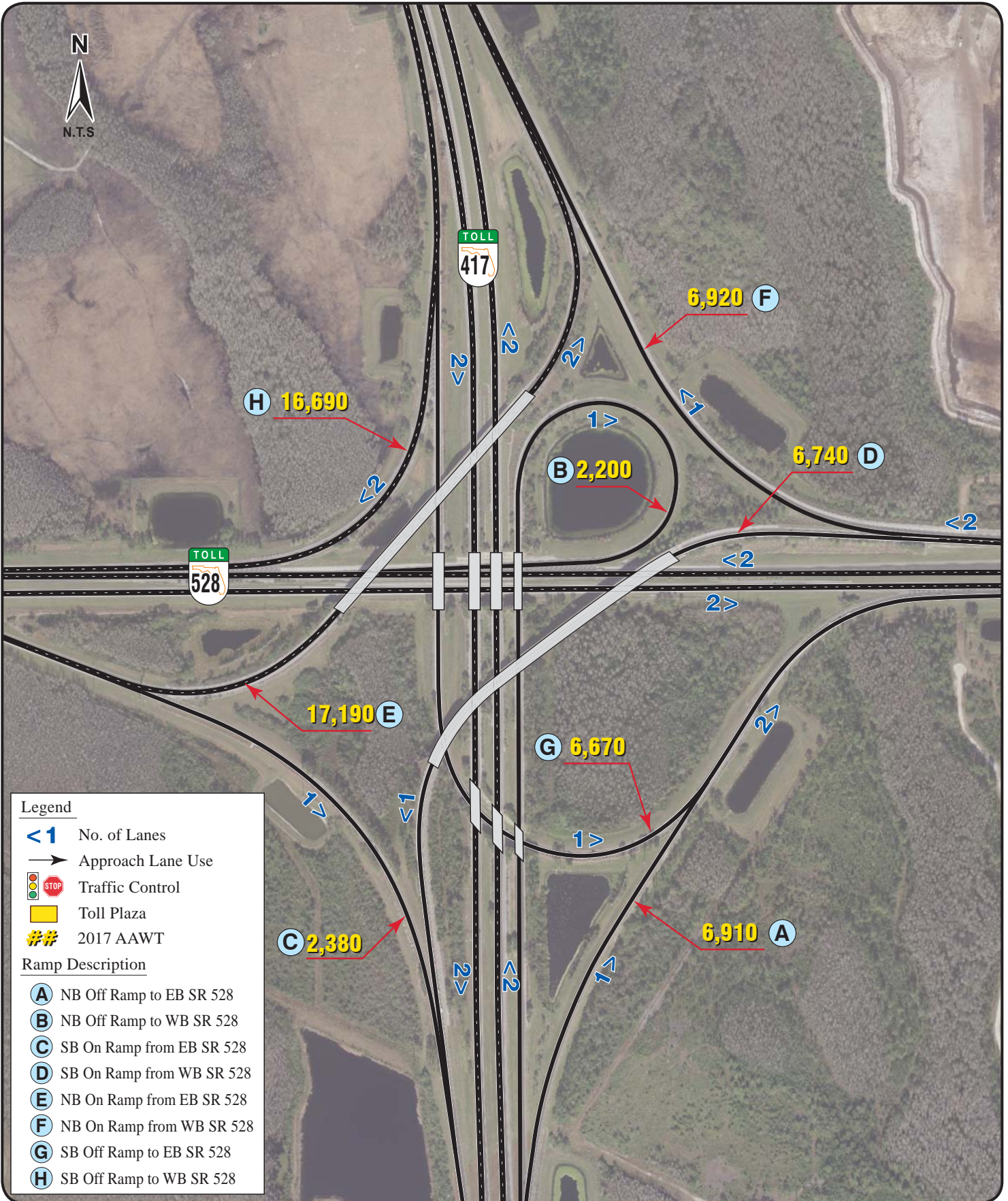
- (A) NB Off Ramp
- (B) NB On Ramp
- (C) SB On Ramp
- (D) SB Off Ramp



Legend

- <1 No. of Lanes
- Approach Lane Use
-   Traffic Control
-  Toll Plaza
- ## 2017 AAWT

Ramp Description

- A** NB Off Ramp to EB SR 528
- B** NB Off Ramp to WB SR 528
- C** SB On Ramp from EB SR 528
- D** SB On Ramp from WB SR 528
- E** NB On Ramp from EB SR 528
- F** NB On Ramp from WB SR 528
- G** SB Off Ramp to EB SR 528
- H** SB Off Ramp to WB SR 528



SR 417 (CENTRAL FLORIDA GREENEWAY)
Exit 26 - Beachline Expressway (SR 528)

Legend

- <1** No. of Lanes
- Approach Lane Use
- STOP** Traffic Control
- Toll Plaza
- ##** 2017 AAWT

Ramp Description

- (A)** SB Off Ramp
- (B)** NB On Ramp
- (C)** SB On Ramp
- (D)** NB Off Ramp

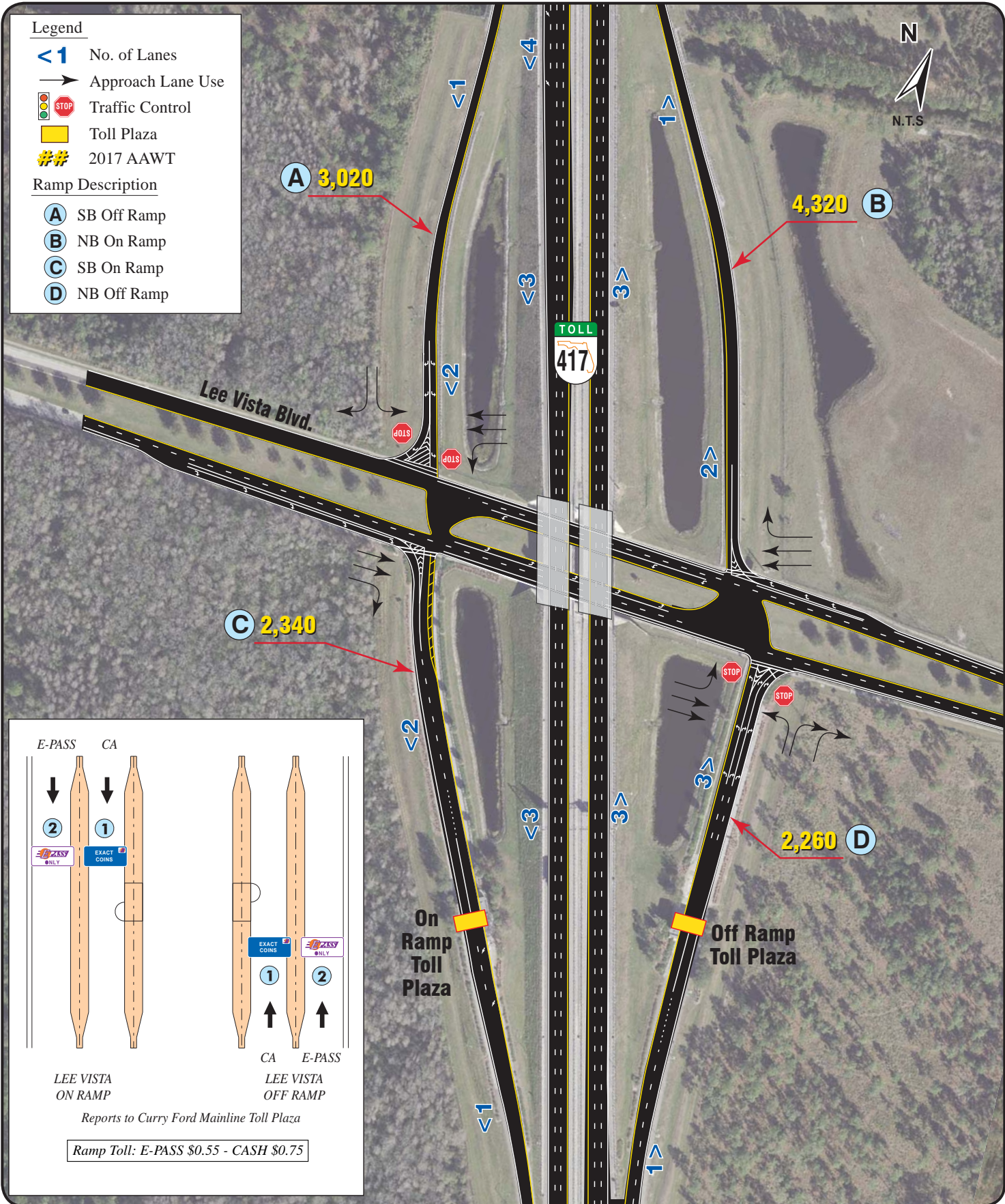

E-PASS	CA
LEE VISTA ON RAMP	LEE VISTA OFF RAMP
Reports to Curry Ford Mainline Toll Plaza	
Ramp Toll: E-PASS \$0.55 - CASH \$0.75	

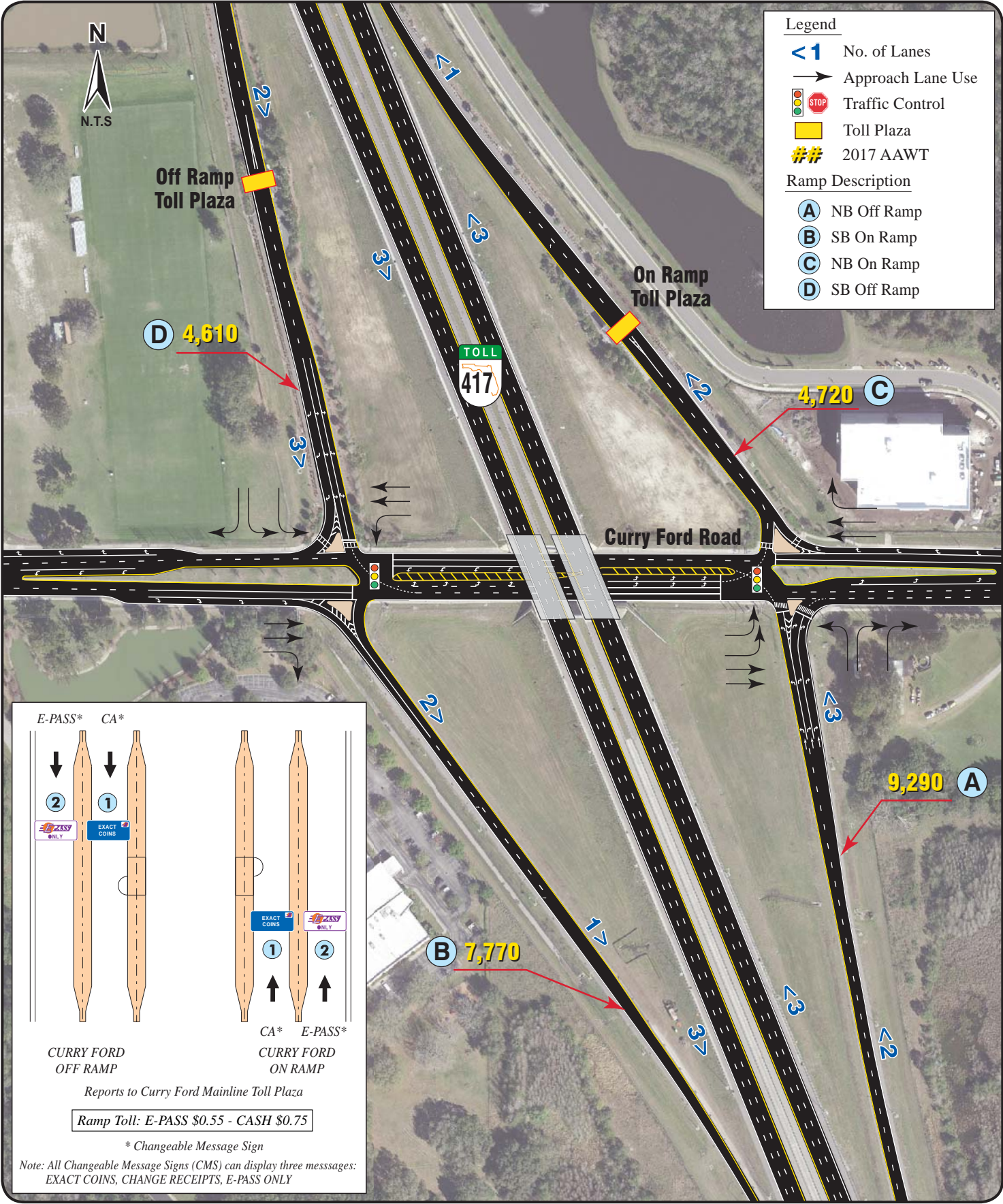

Legend

- <1 No. of Lanes
- Approach Lane Use
- 🚦 STOP Traffic Control
- 🟡 Toll Plaza
- ## 2017 AAWT

Ramp Description

- (A) NB Off Ramp
- (B) SB On Ramp
- (C) NB On Ramp
- (D) SB Off Ramp

E-PASS* CA*

Curry Ford Off Ramp **Curry Ford On Ramp**

Reports to Curry Ford Mainline Toll Plaza

Ramp Toll: E-PASS \$0.55 - CASH \$0.75

** Changeable Message Sign*

Note: All Changeable Message Signs (CMS) can display three messages: EXACT COINS, CHANGE RECEIPTS, E-PASS ONLY

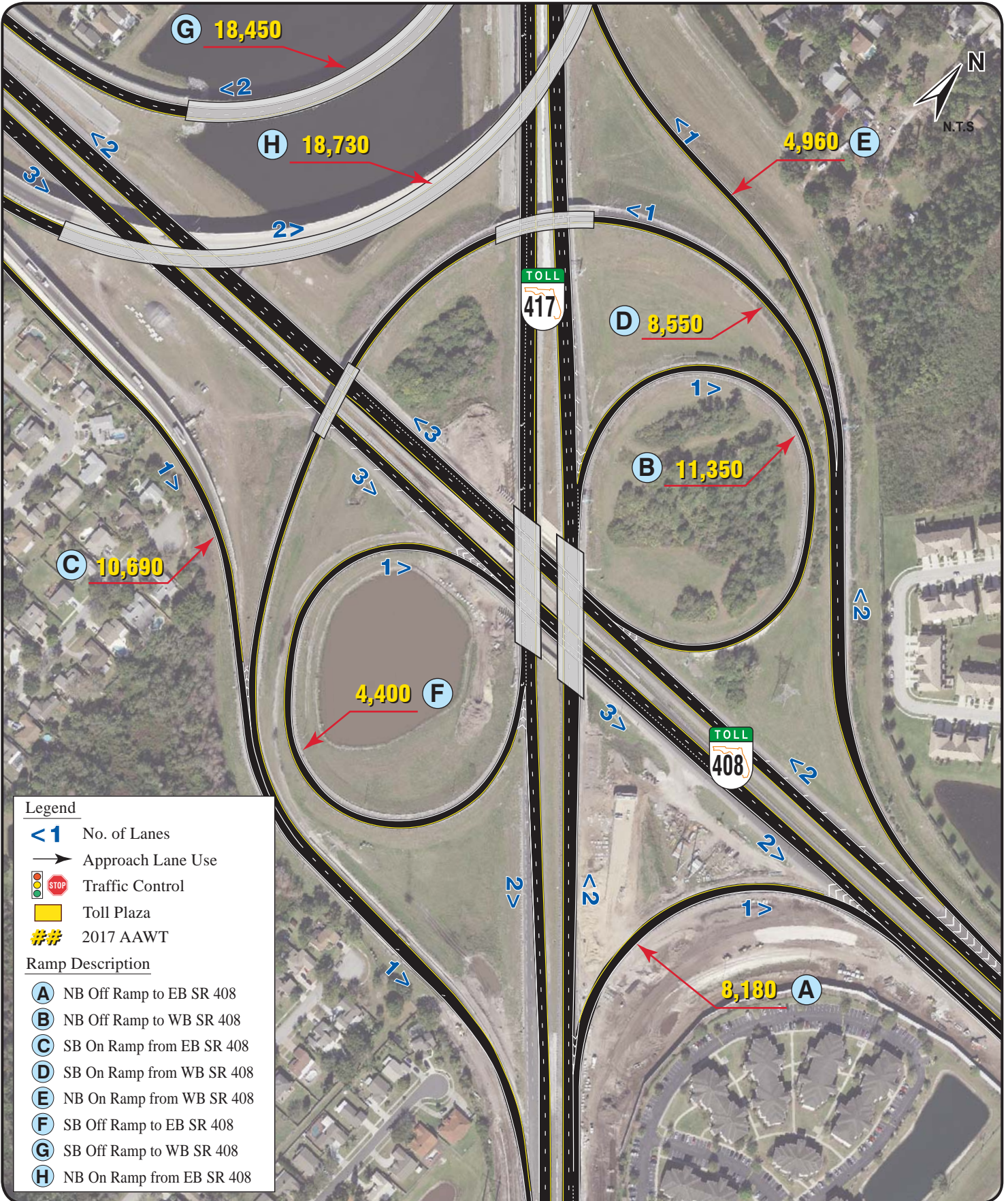

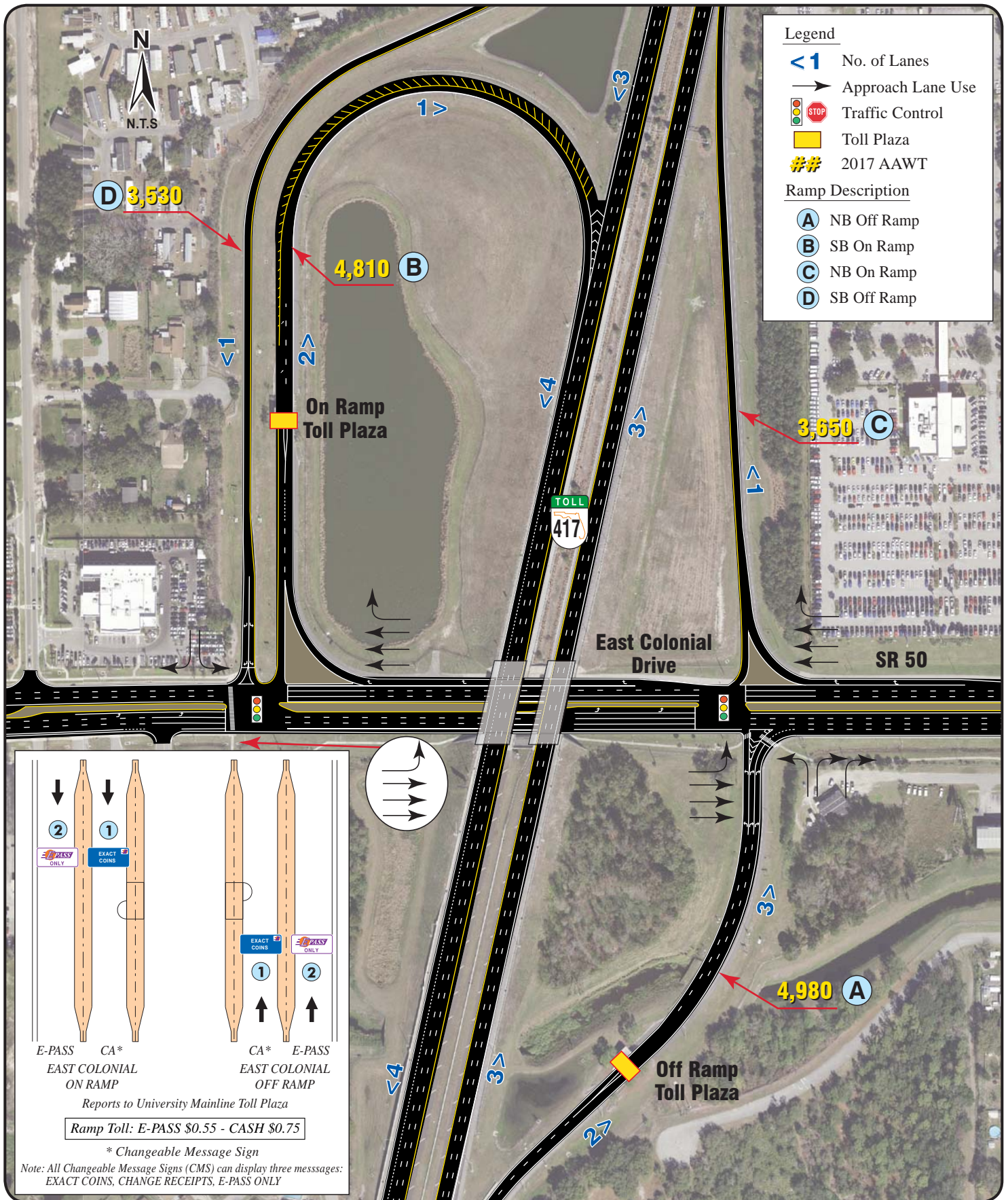

Legend

- <1 No. of Lanes
- Approach Lane Use
- STOP Traffic Control
- Toll Plaza
- ## 2017 AAWT

Ramp Description

- (A) NB Off Ramp
- (B) SB On Ramp
- (C) NB On Ramp
- (D) SB Off Ramp

E-PASS ONLY CA*
EAST COLONIAL ON RAMP

EXACT COINS E-PASS ONLY
CA* E-PASS
EAST COLONIAL OFF RAMP

Reports to University Mainline Toll Plaza

Ramp Toll: E-PASS \$0.55 - CASH \$0.75

* Changeable Message Sign

Note: All Changeable Message Signs (CMS) can display three messages:
EXACT COINS, CHANGE RECEIPTS, E-PASS ONLY

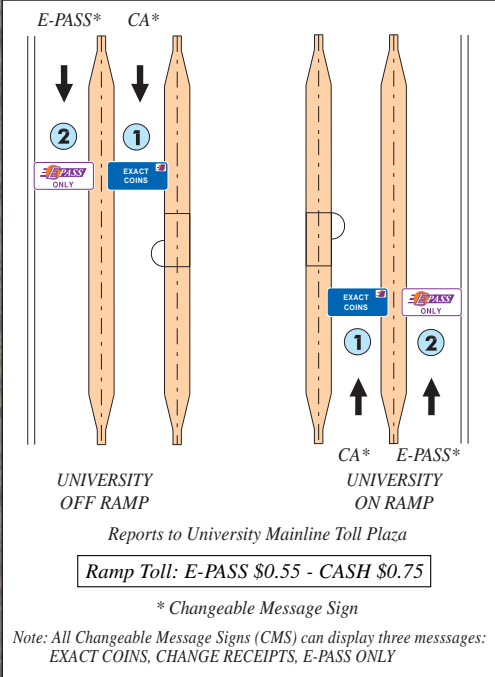
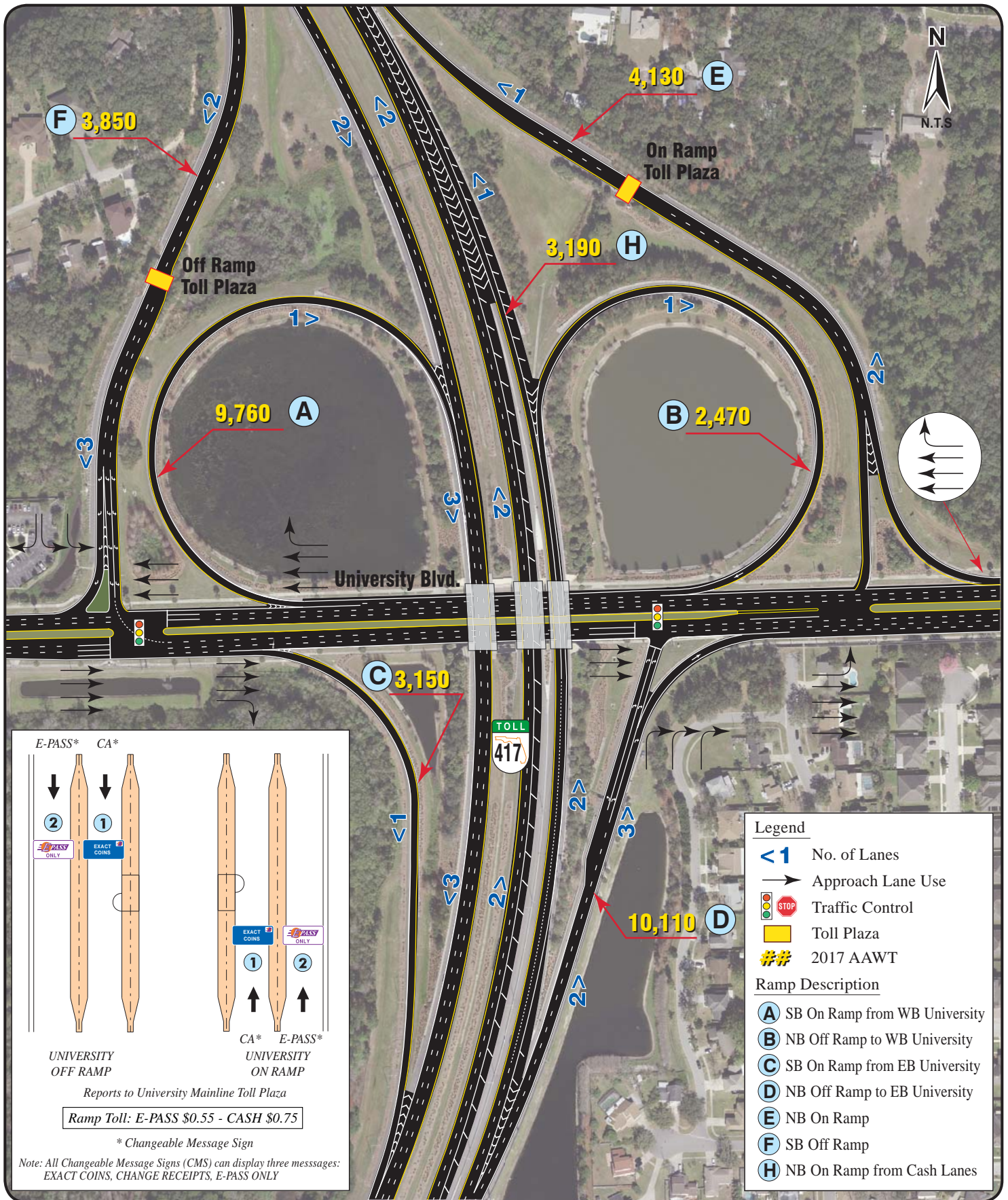

Legend

- <1 No. of Lanes
- Approach Lane Use
- Traffic Control
- Toll Plaza
- ## 2017 AAWT

Ramp Description

- A SB On Ramp from WB University
- B NB Off Ramp to WB University
- C SB On Ramp from EB University
- D NB Off Ramp to EB University
- E NB On Ramp
- F SB Off Ramp
- H NB On Ramp from Cash Lanes

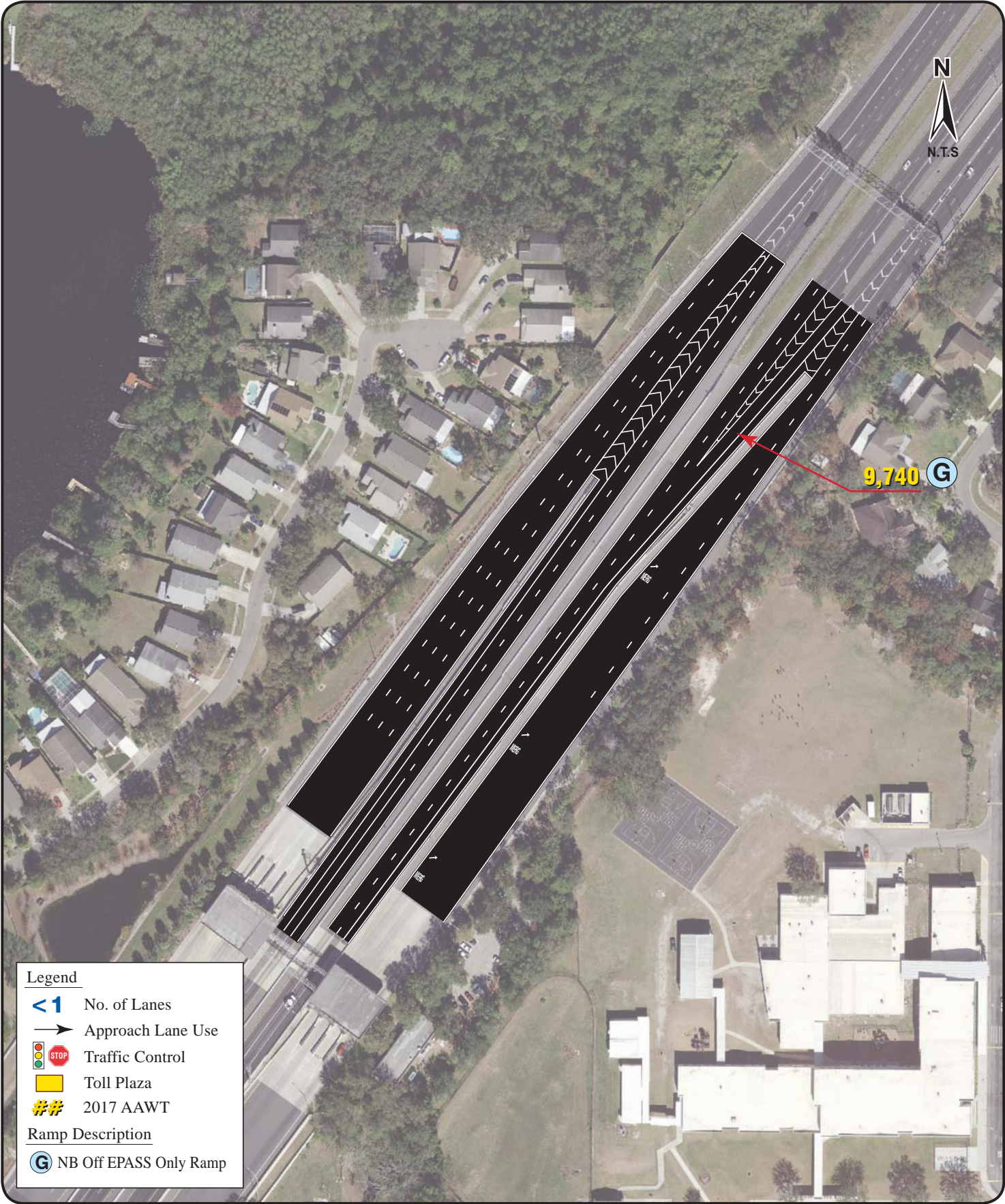

Legend

- < 1** No. of Lanes
- Approach Lane Use
- STOP** Traffic Control
- Toll Plaza
- ##** 2017 AAWT
- Ramp Description**
- NB Off EPASS Only Ramp

Western Beltway and Wekiva Parkway



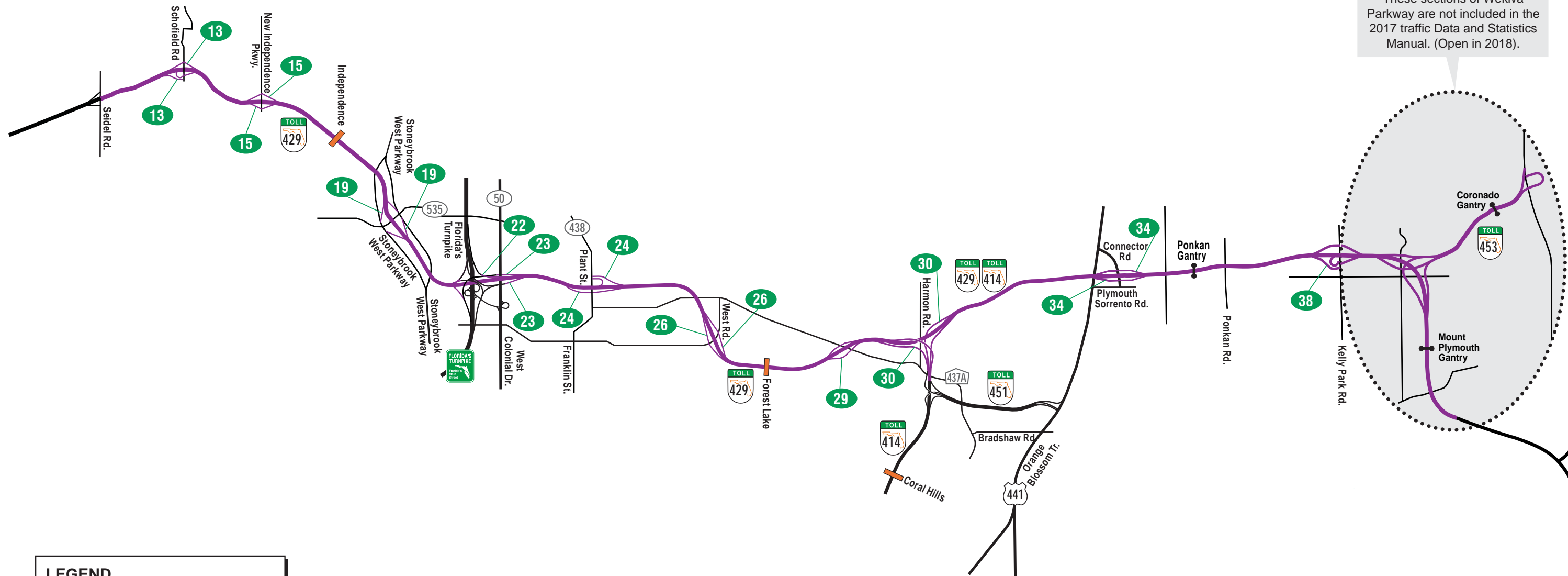

These sections of Wekiva Parkway are not included in the 2017 traffic Data and Statistics Manual. (Open in 2018).

LEGEND

- Exit Number
- Existing SR 429
- Mainline Toll Plaza
- Mainline Toll Gantry

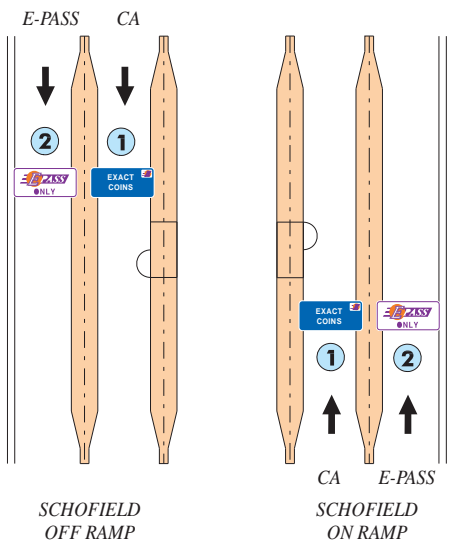

Reports to Independence Mainline Toll Plaza

Ramp Toll: E-PASS \$0.55 - CASH \$0.75

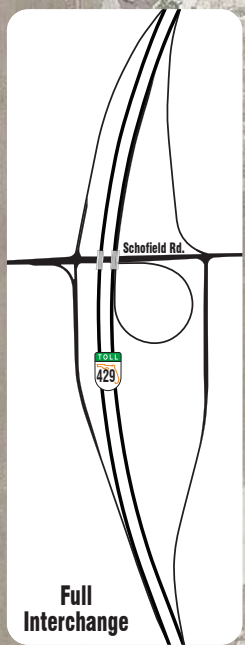

E 1,510

D 1,890

220 B

C 220

430 A

Legend

- <1 No. of Lanes
- Approach Lane Use
- STOP Traffic Control
- Yellow Box Toll Plaza
- ## 2017 AAWT

Ramp Description

- A** NB Off Ramp
- B** NB Loop On Ramp
- C** SB On Ramp
- D** NB On Ramp
- E** SB Off Ramp

Schofield Rd.

On Ramp Toll Plaza

Off Ramp Toll Plaza

TOLL 429

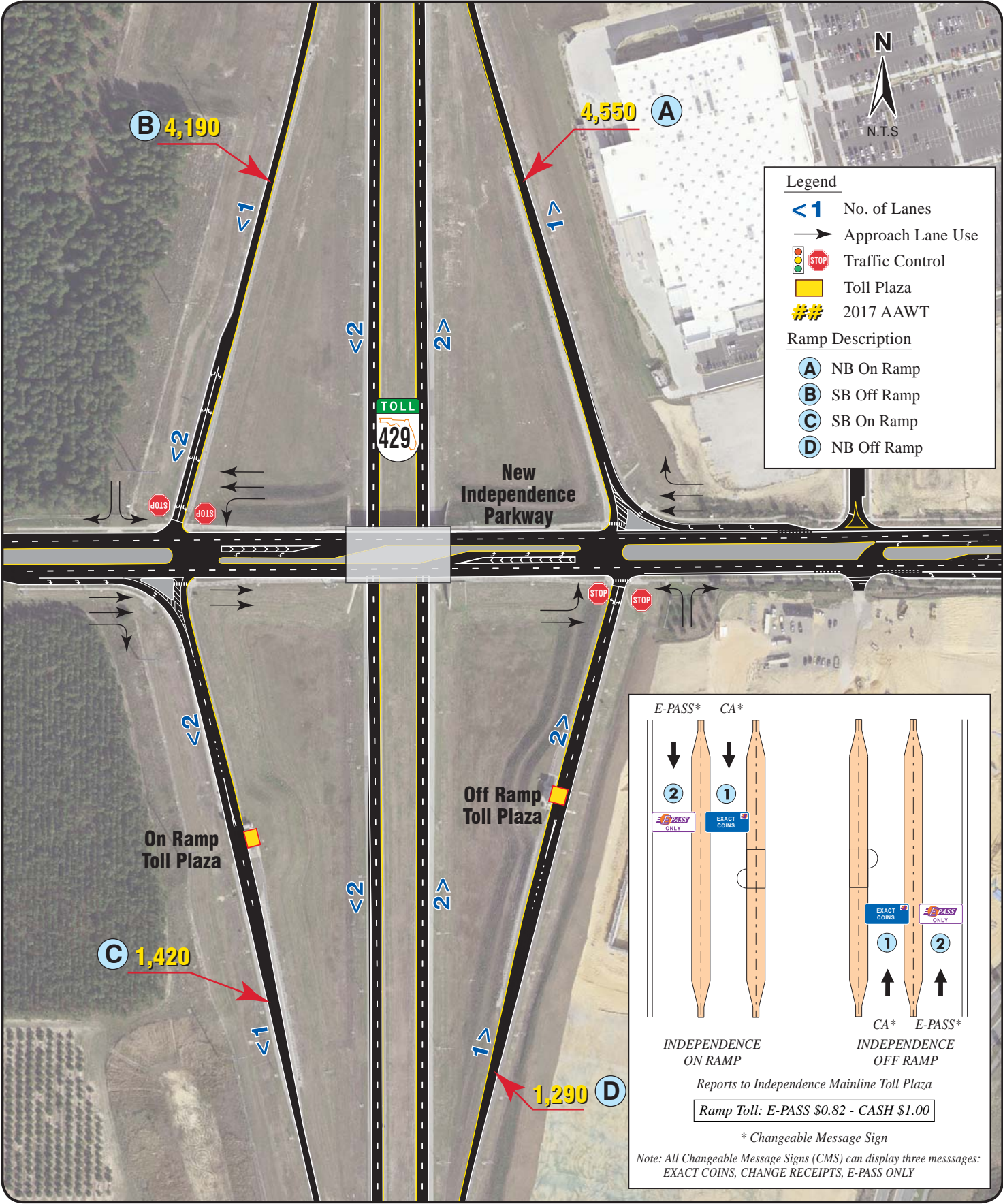

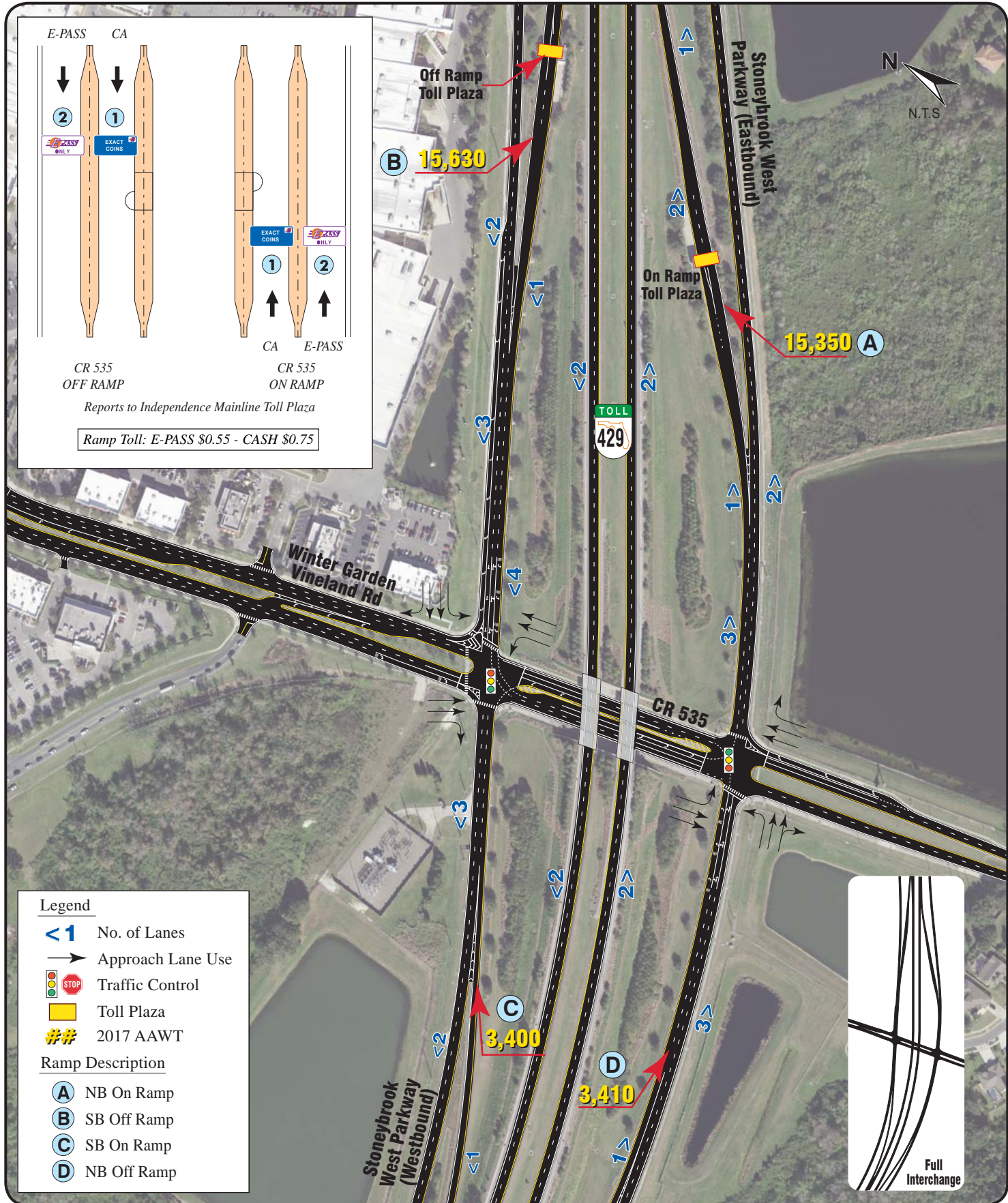
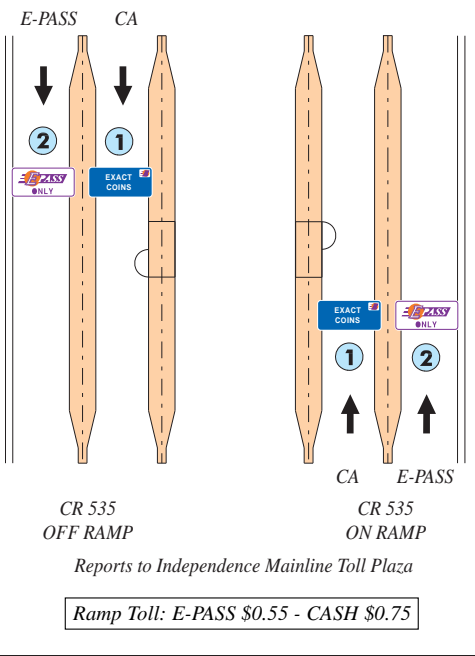

- Legend**
- <1> No. of Lanes
 - Approach Lane Use
 - Traffic Control
 - Toll Plaza
 - ##** 2017 AAWT
- Ramp Description**
- (A)** NB On Ramp
 - (B)** SB Off Ramp
 - (C)** SB On Ramp
 - (D)** NB Off Ramp



SR 429 (WESTERN BELTWAY AND WEKIVA PARKWAY)
Exit 19 - CR 535

Legend

- <1 No. of Lanes
- ➔ Approach Lane Use
- 🚦 Traffic Control
- 🟡 Toll Plaza
- ## 2017 AAWT

Ramp Description

- A** NB On Ramp from SR 50
- B** SB Off Ramp to SR 50
- C** SB Off Ramp to NB Florida's Turnpike
- D** SB Off Ramp to SB Florida's Turnpike
- E** NB On Ramp from SB Florida's Turnpike
- F** NB On Ramp from NB Florida's Turnpike
- G** SB On Ramp from SR 50
- H** NB Off Ramp to SR 50
- I** SB On Ramp from SB Florida's Turnpike
- J** SB On Ramp from NB Florida's Turnpike
- K** NB Off Ramp to SB Florida's Turnpike
- L** NB Off Ramp to NB Florida's Turnpike

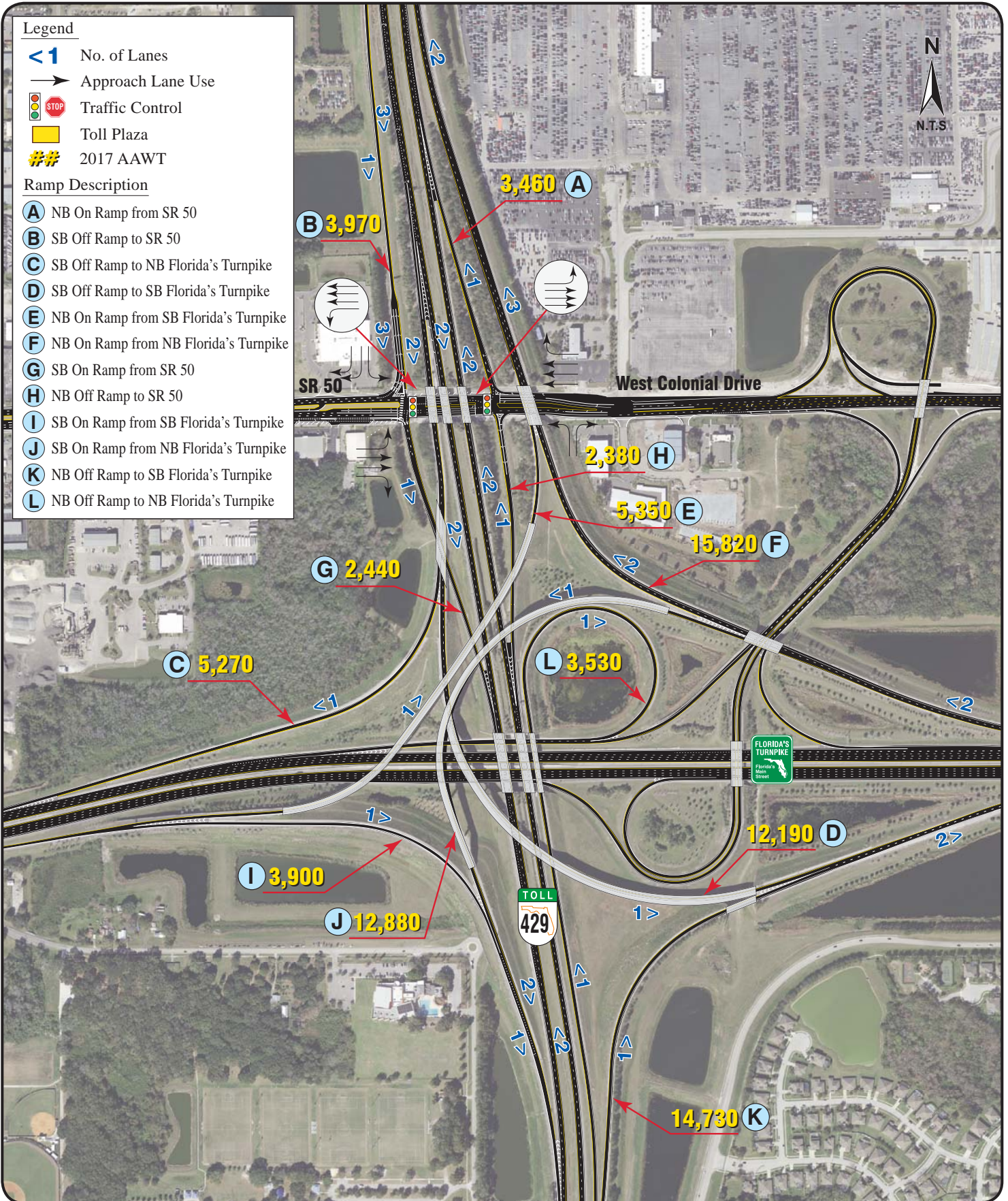

Legend

- < 1 No. of Lanes
- Approach Lane Use
- Traffic Control
- Toll Plaza
- 2017 AAWT

Ramp Description

- (A)** SB On Ramp
- (B)** SB Off Ramp
- (C)** NB On Ramp
- (D)** NB Off Ramp

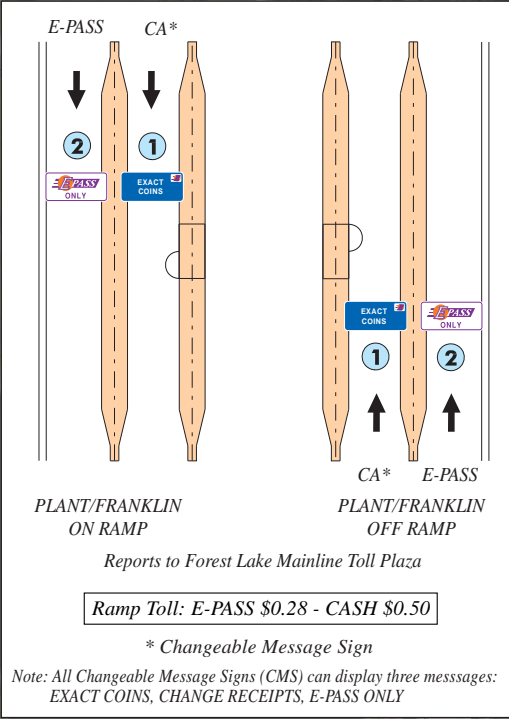
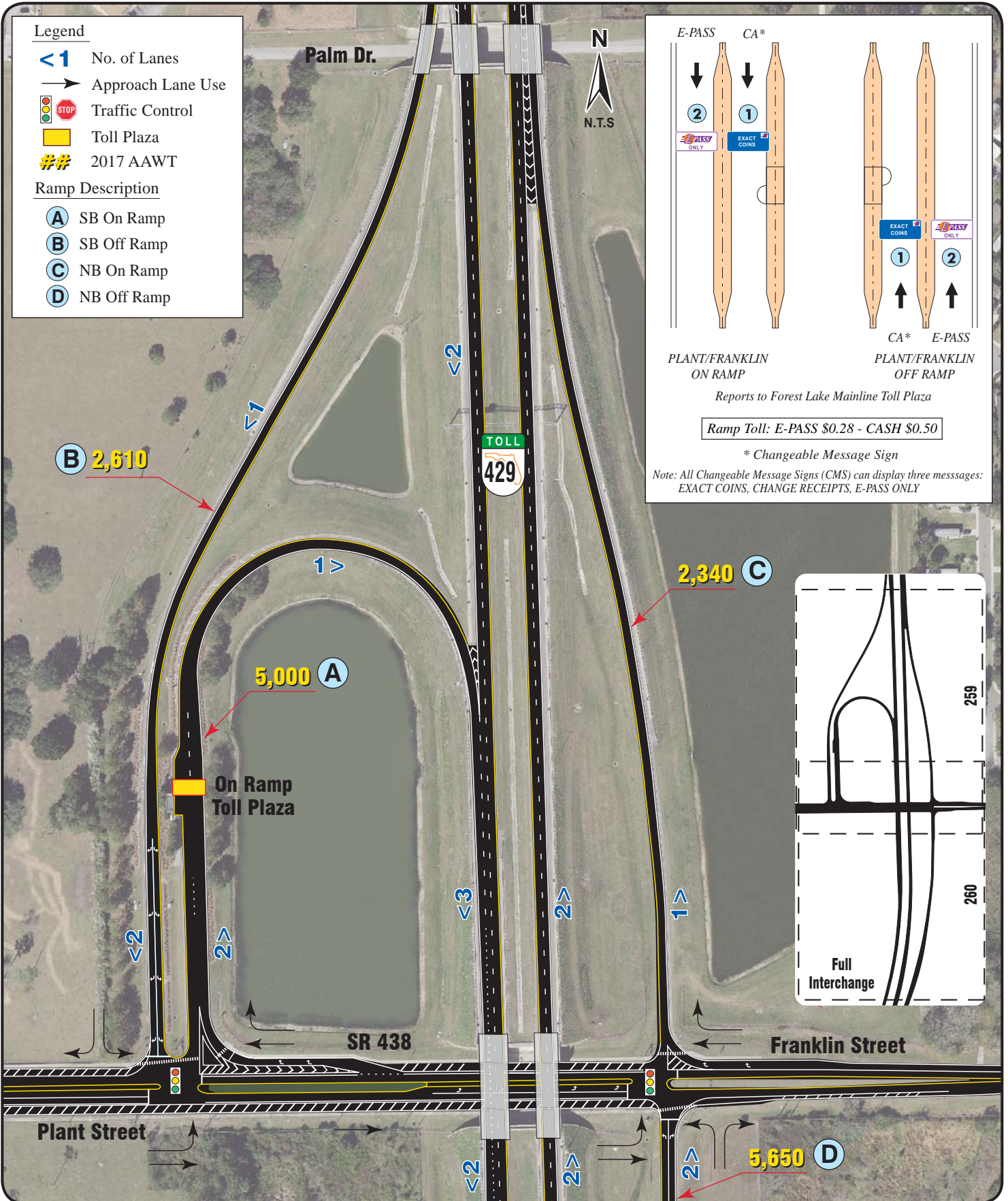

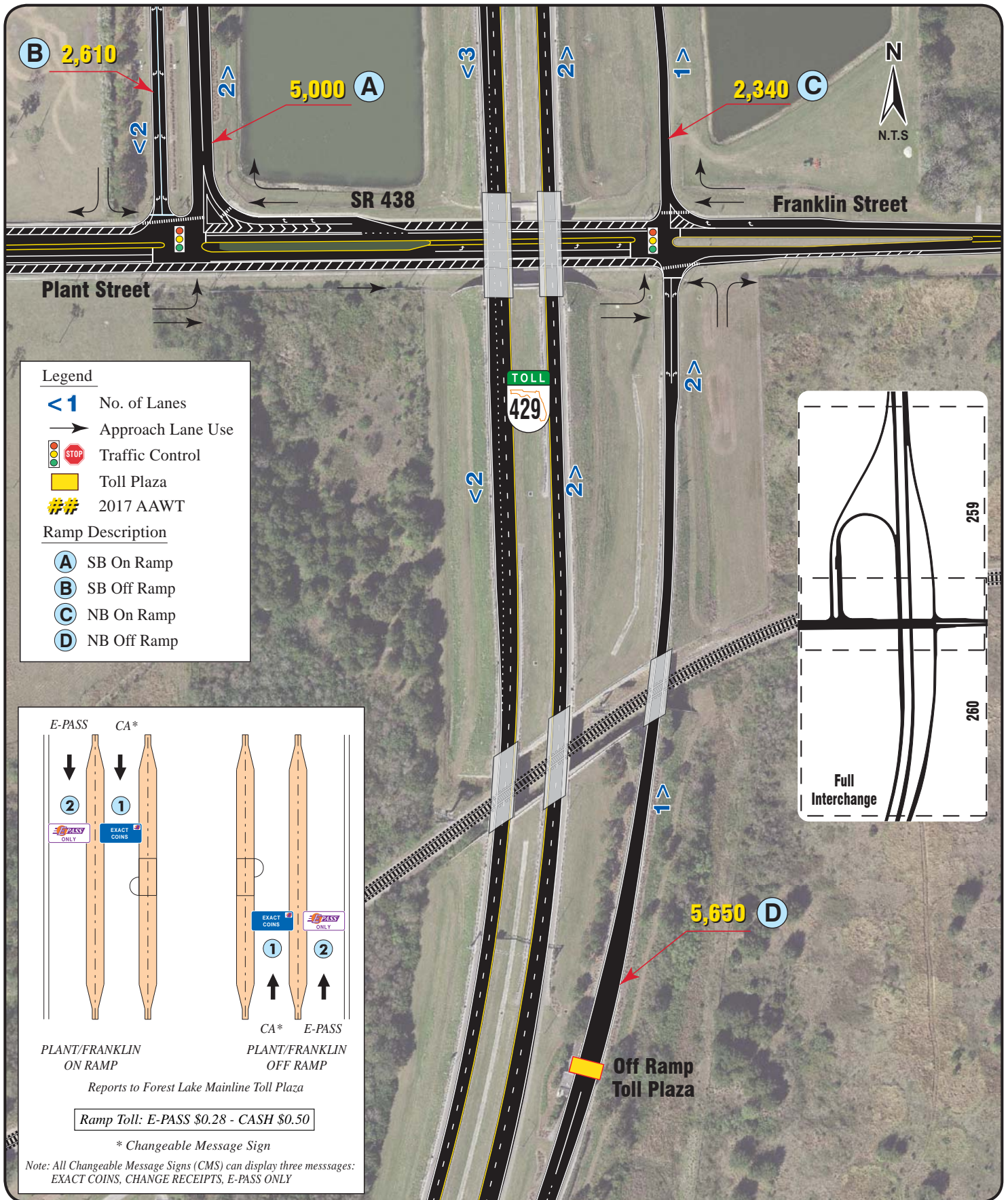

Legend

- <1 No. of Lanes
- Approach Lane Use
- Traffic Control
- Toll Plaza
- ## 2017 AAWT

Ramp Description

- (A) SB On Ramp
- (B) SB Off Ramp
- (C) NB On Ramp
- (D) NB Off Ramp

E-PASS CA*

PLANT/FRANKLIN ON RAMP

CA* E-PASS

PLANT/FRANKLIN OFF RAMP

Reports to Forest Lake Mainline Toll Plaza

Ramp Toll: E-PASS \$0.28 - CASH \$0.50

* Changeable Message Sign

Note: All Changeable Message Signs (CMS) can display three messages: EXACT COINS, CHANGE RECEIPTS, E-PASS ONLY

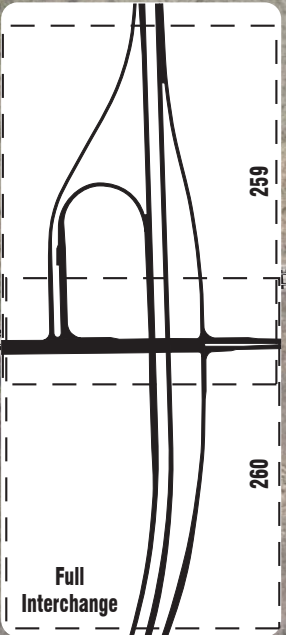

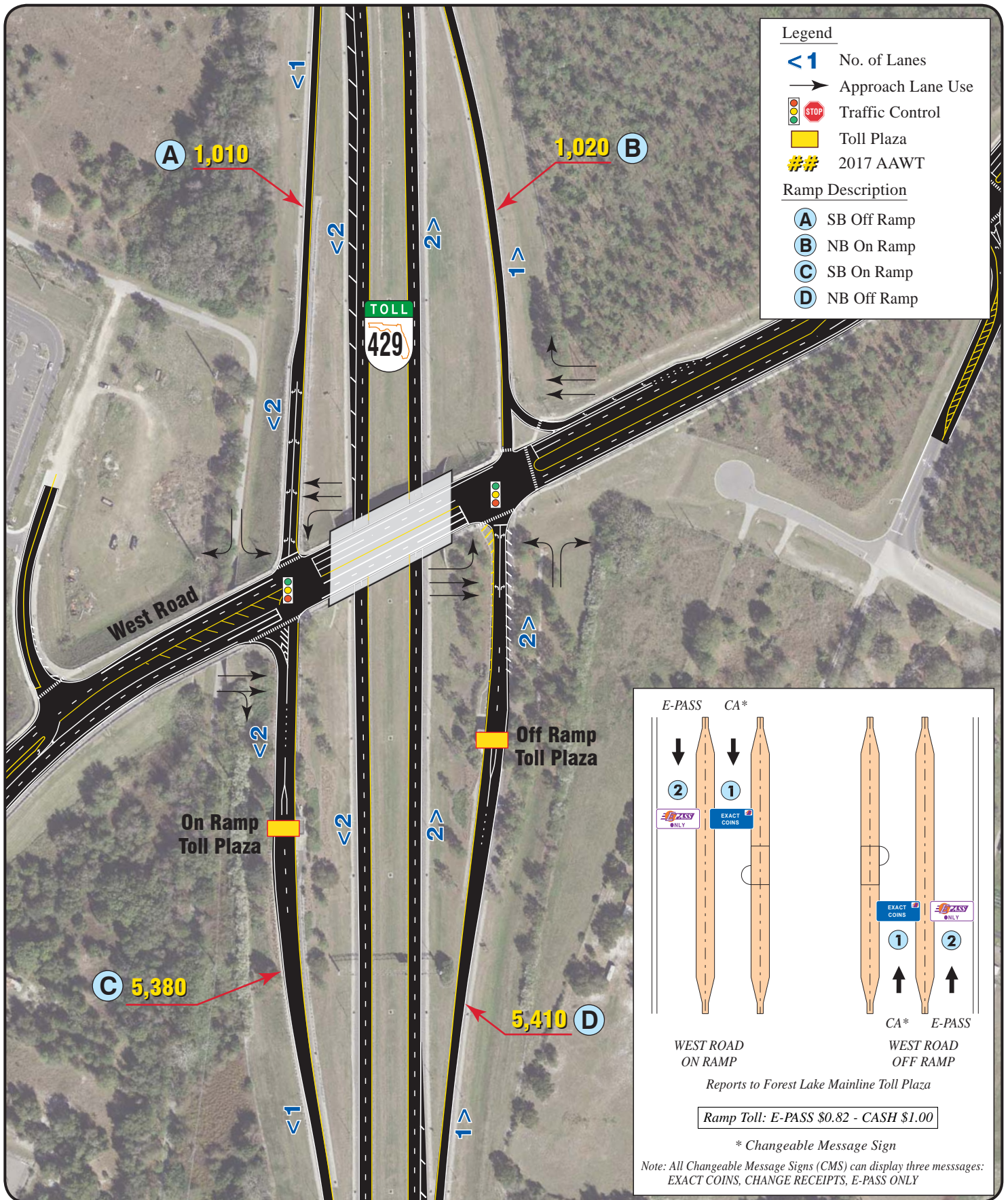



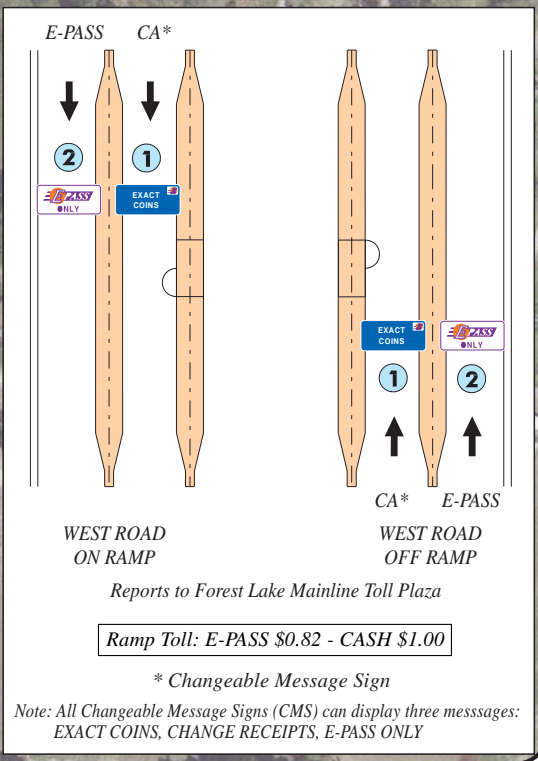

- Legend**
- <1 No. of Lanes
 - Approach Lane Use
 - 🚦 STOP Traffic Control
 - 🟡 Toll Plaza
 - ## 2017 AAWT
- Ramp Description**
- Ⓐ SB Off Ramp
 - Ⓑ NB On Ramp
 - Ⓒ SB On Ramp
 - Ⓓ NB Off Ramp







Legend

-  No. of Lanes
-  Approach Lane Use
-  Traffic Control
-  Toll Plaza
-  2017 AAWT

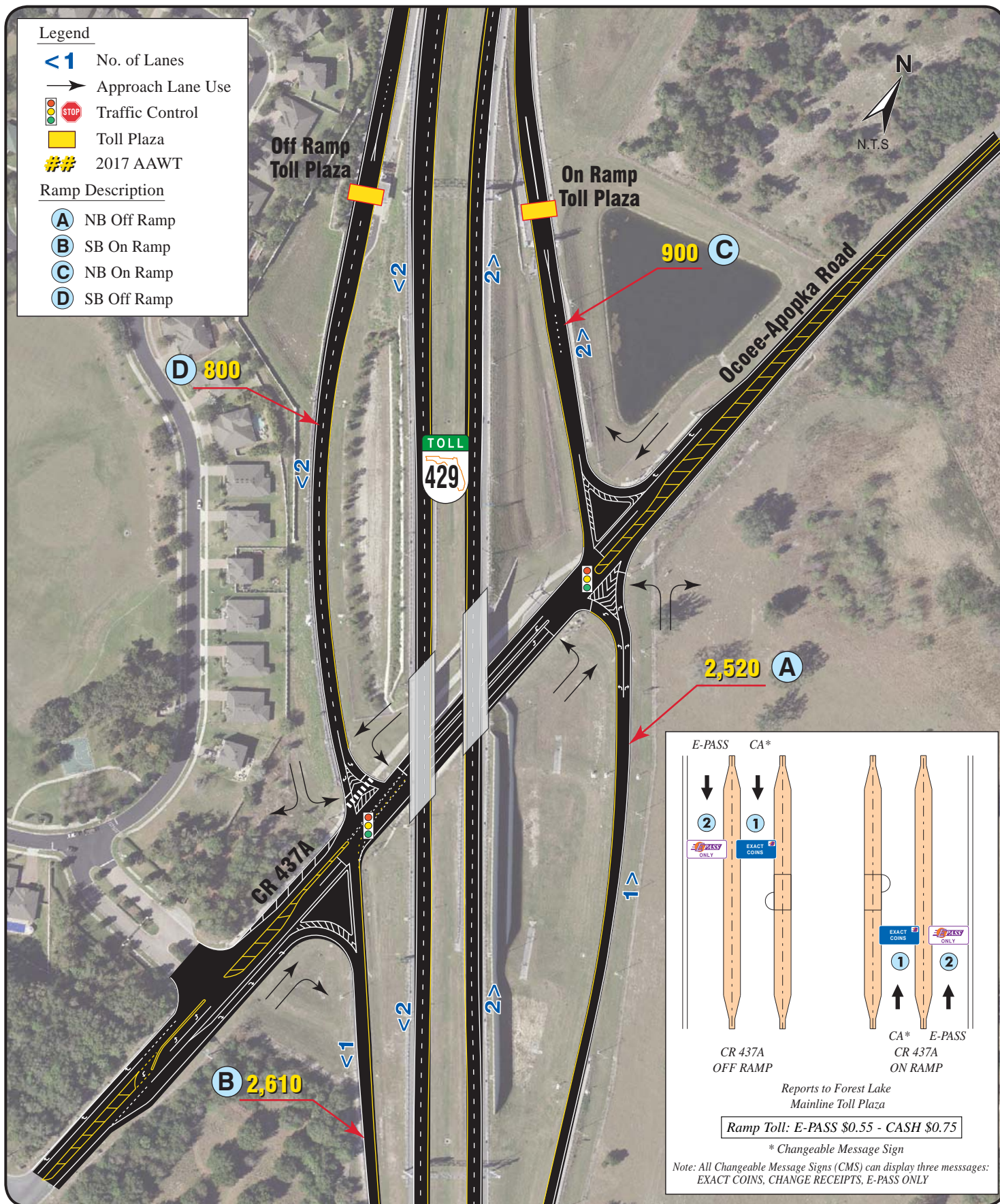
Ramp Description

- (A)** NB Off Ramp
- (B)** SB On Ramp
- (C)** NB On Ramp
- (D)** SB Off Ramp



E-PASS	CA*		
↓	↓	↑	↑
2	1	1	2
			
CR 437A OFF RAMP	CR 437A ON RAMP	CR 437A ON RAMP	CR 437A ON RAMP

Reports to Forest Lake Mainline Toll Plaza

Ramp Toll: E-PASS \$0.55 - CASH \$0.75

* Changeable Message Sign

Note: All Changeable Message Signs (CMS) can display three messages: EXACT COINS, CHANGE RECEIPTS, E-PASS ONLY

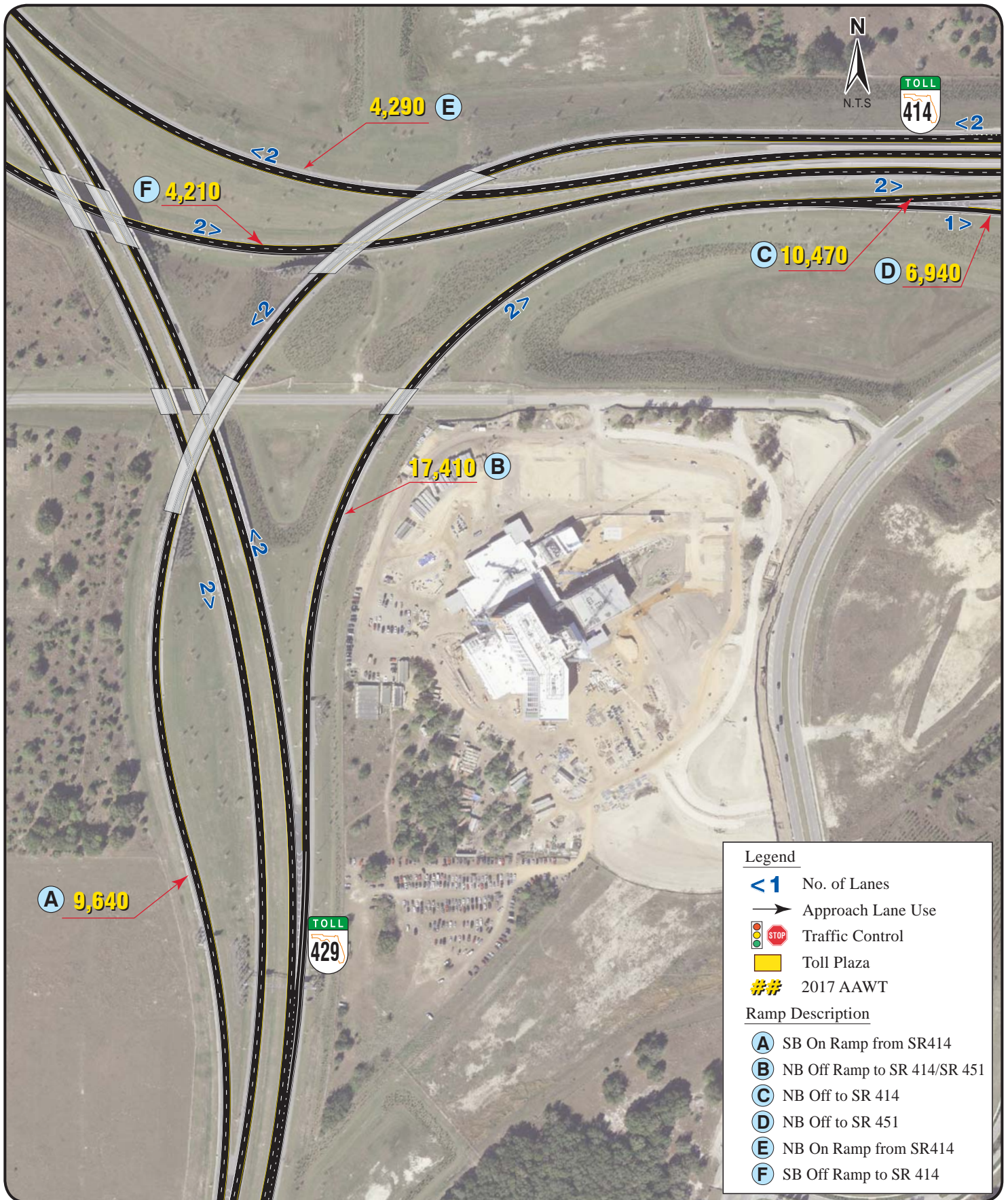



Legend

- <1 No. of Lanes
- Approach Lane Use
- 🚦 STOP Traffic Control
- 🟡 Toll Plaza
- ## 2017 AAWT

Ramp Description

- Ⓐ NB Off Ramp
- Ⓑ SB On Ramp
- Ⓒ SB Off Ramp
- Ⓓ NB On Ramp

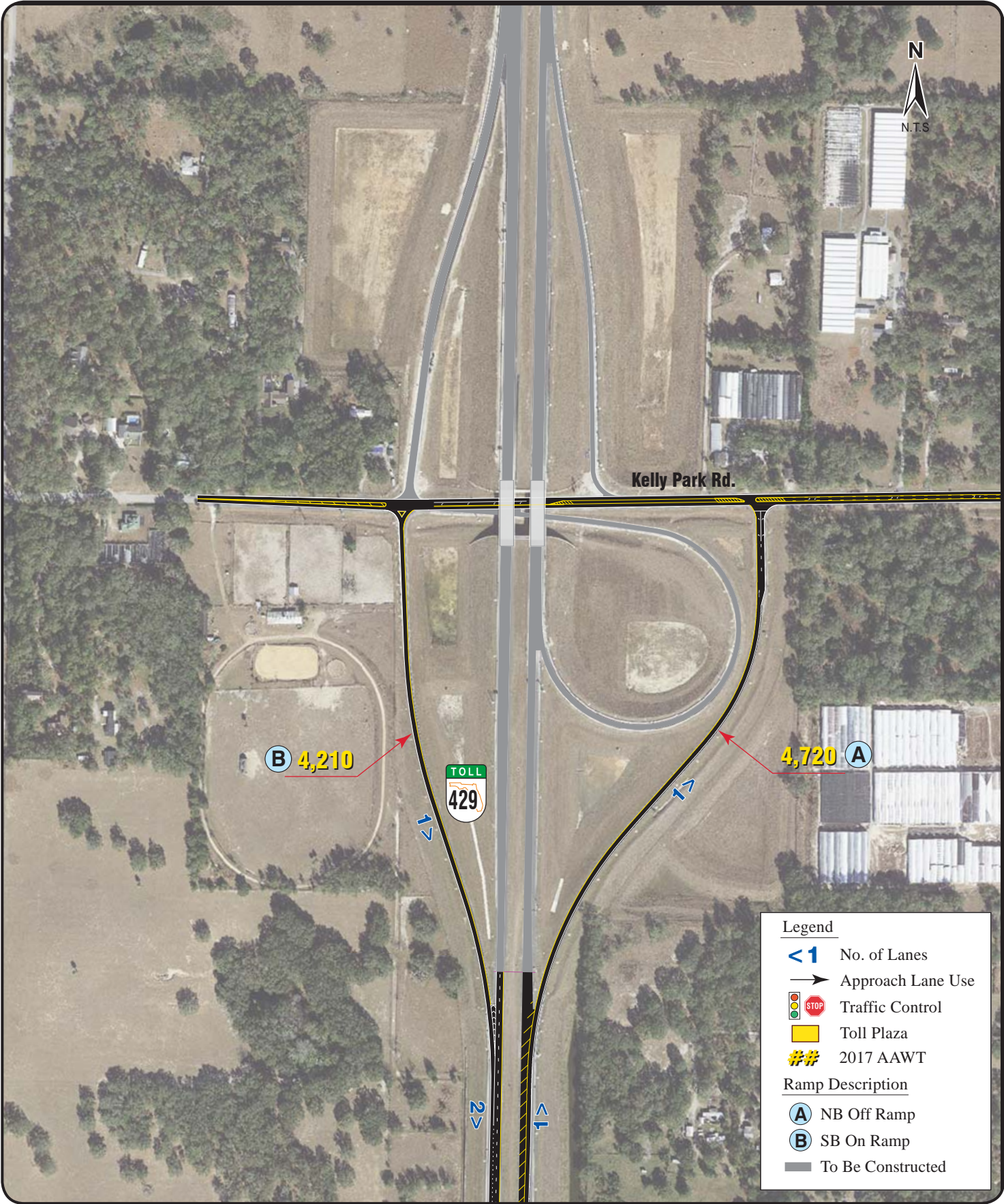

Kelly Park Rd.

B 4,210



4,720 **A**

Legend

- <1 No. of Lanes
- Approach Lane Use
- 🚦 STOP Traffic Control
- 🟡 Toll Plaza
- ### 2017 AAWT

Ramp Description

- A** NB Off Ramp
- B** SB On Ramp
- ▬ To Be Constructed

Apopka Expressway



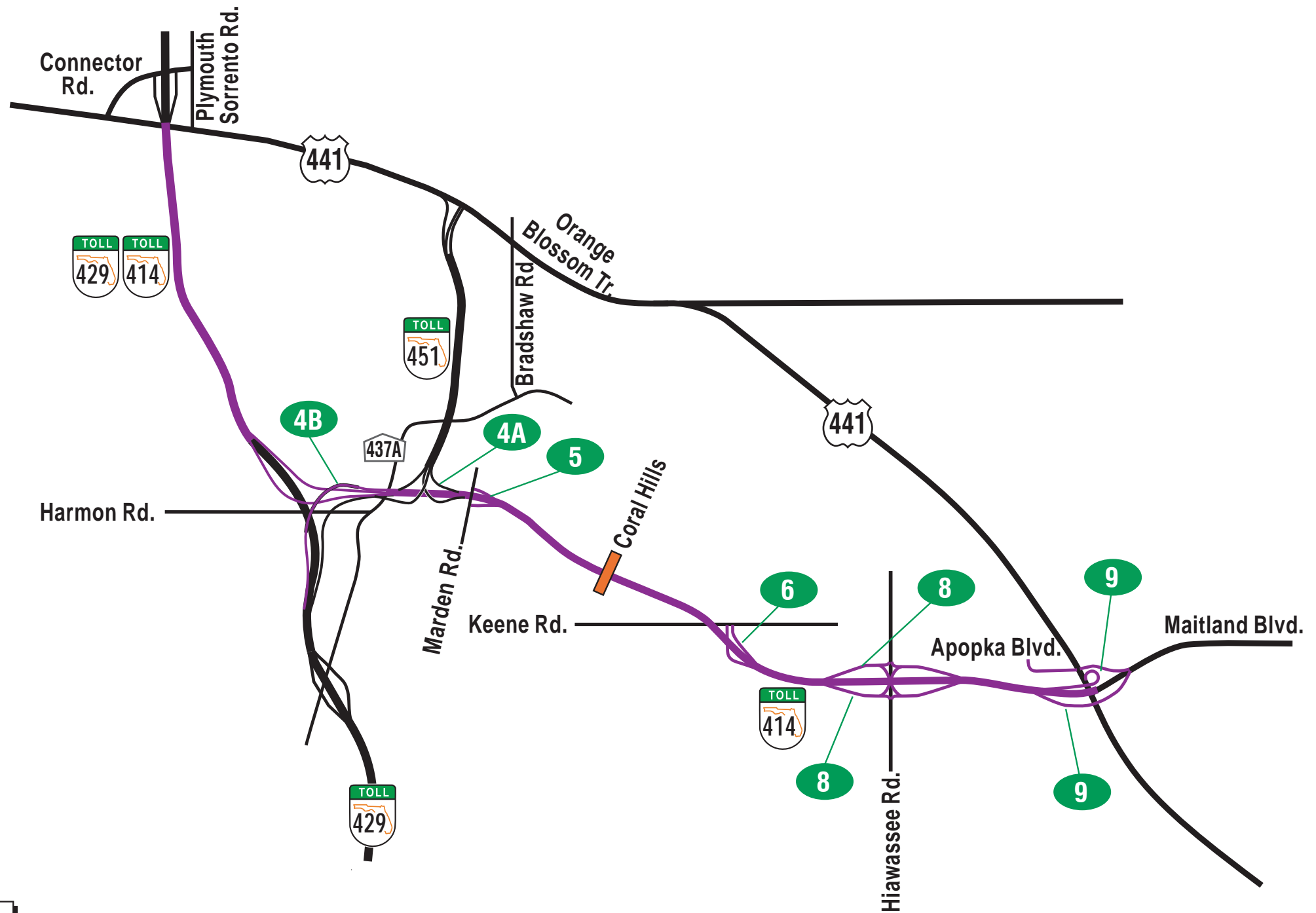



LEGEND

- Exit Number
- Existing SR 414
- Mainline Toll Plaza



SR 414 - APOPKA EXPRESSWAY
Exit Numbers

Legend

- < 1 No. of Lanes
- Approach Lane Use
-  Traffic Control
-  Toll Plaza
- ## 2017 AAWT

Ramp Description

- A** SB Off Ramp to EB SR 414
- B** NB On Ramp from SR 429
- C** SB Off to SR 429
- D** NB On from WB SR 414
- E** EB On Ramp from NB SR 429
- F** WB Off Ramp to SB SR 429

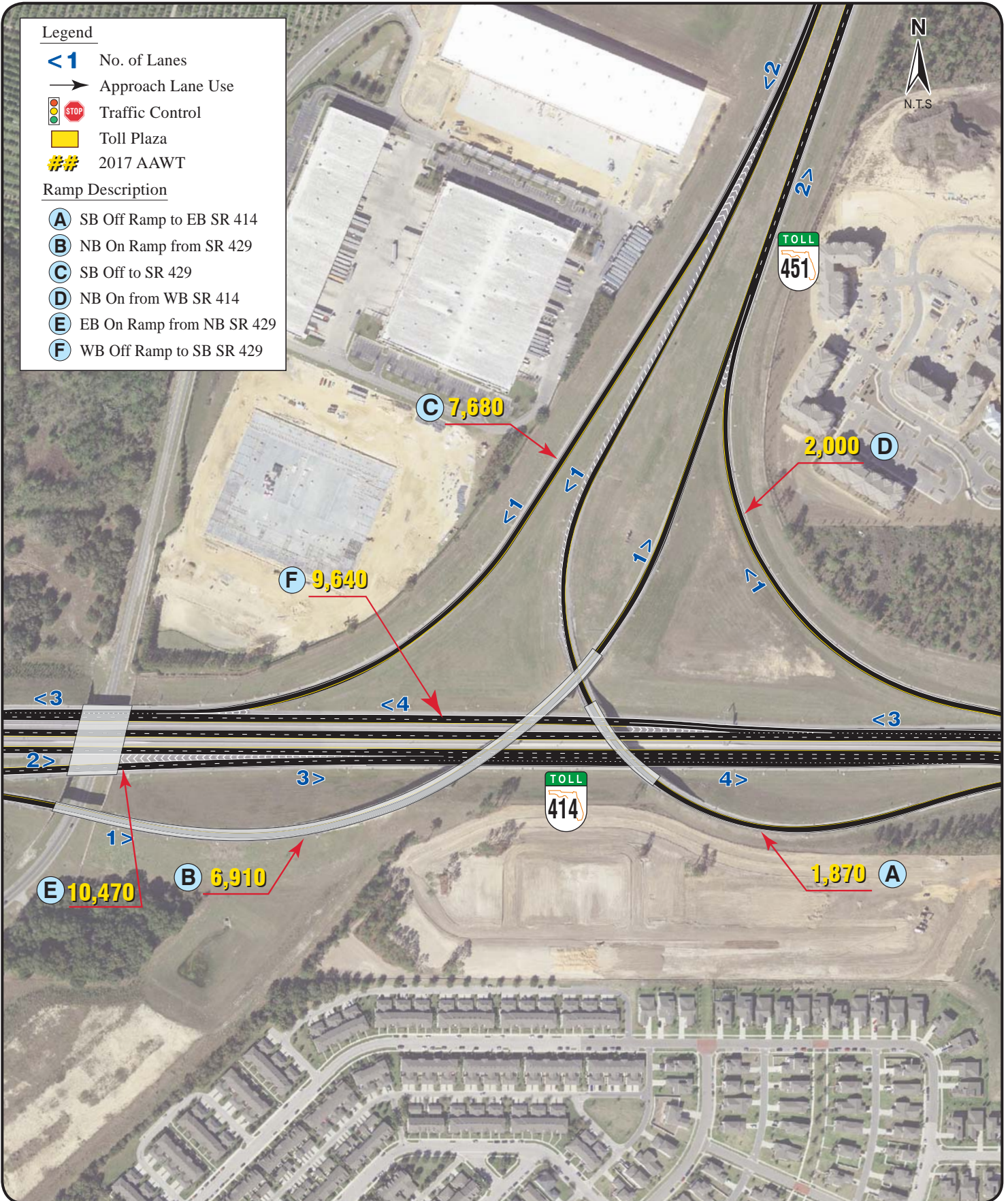

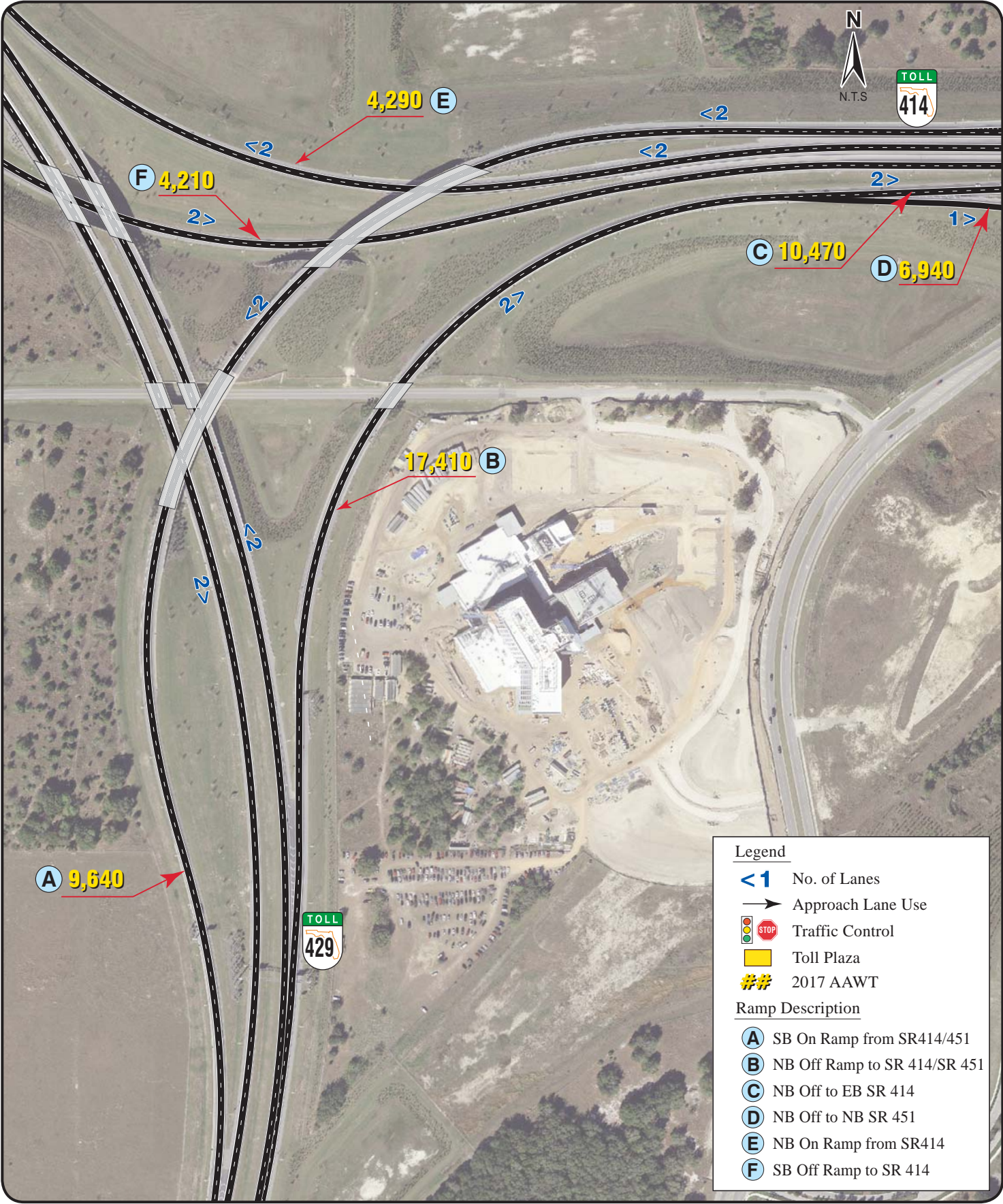

Legend

- <1 No. of Lanes
- Approach Lane Use
- Traffic Control
- Toll Plaza
- ## 2017 AAWT

Ramp Description

- (A)** SB On Ramp from SR414/451
- (B)** NB Off Ramp to SR 414/SR 451
- (C)** NB Off to EB SR 414
- (D)** NB Off to NB SR 451
- (E)** NB On Ramp from SR414
- (F)** SB Off Ramp to SR 414

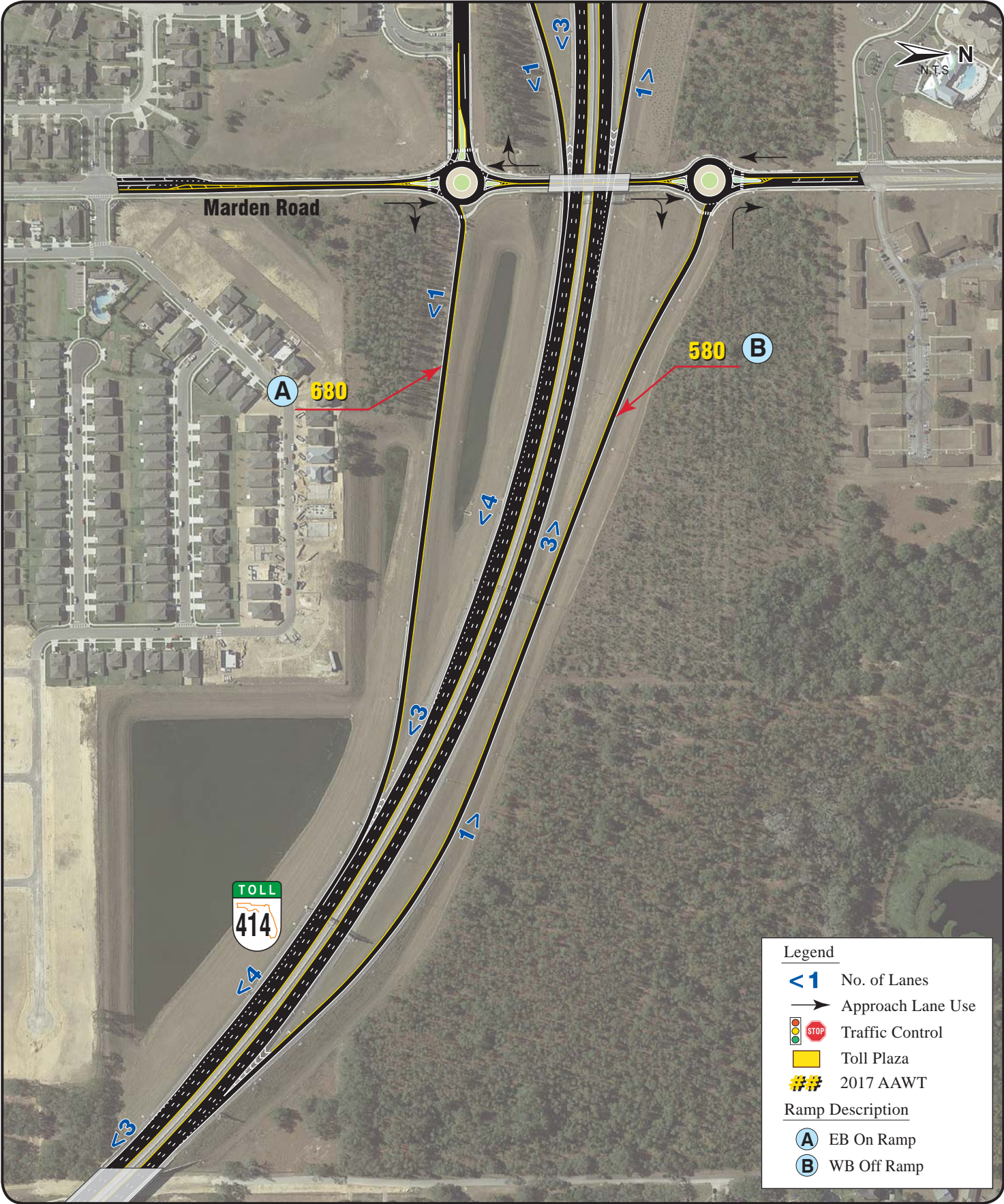

Legend

- <1> No. of Lanes
- Approach Lane Use
- Traffic Control
- Toll Plaza
- 2017 AAWT

Ramp Description

- EB On Ramp
- WB Off Ramp

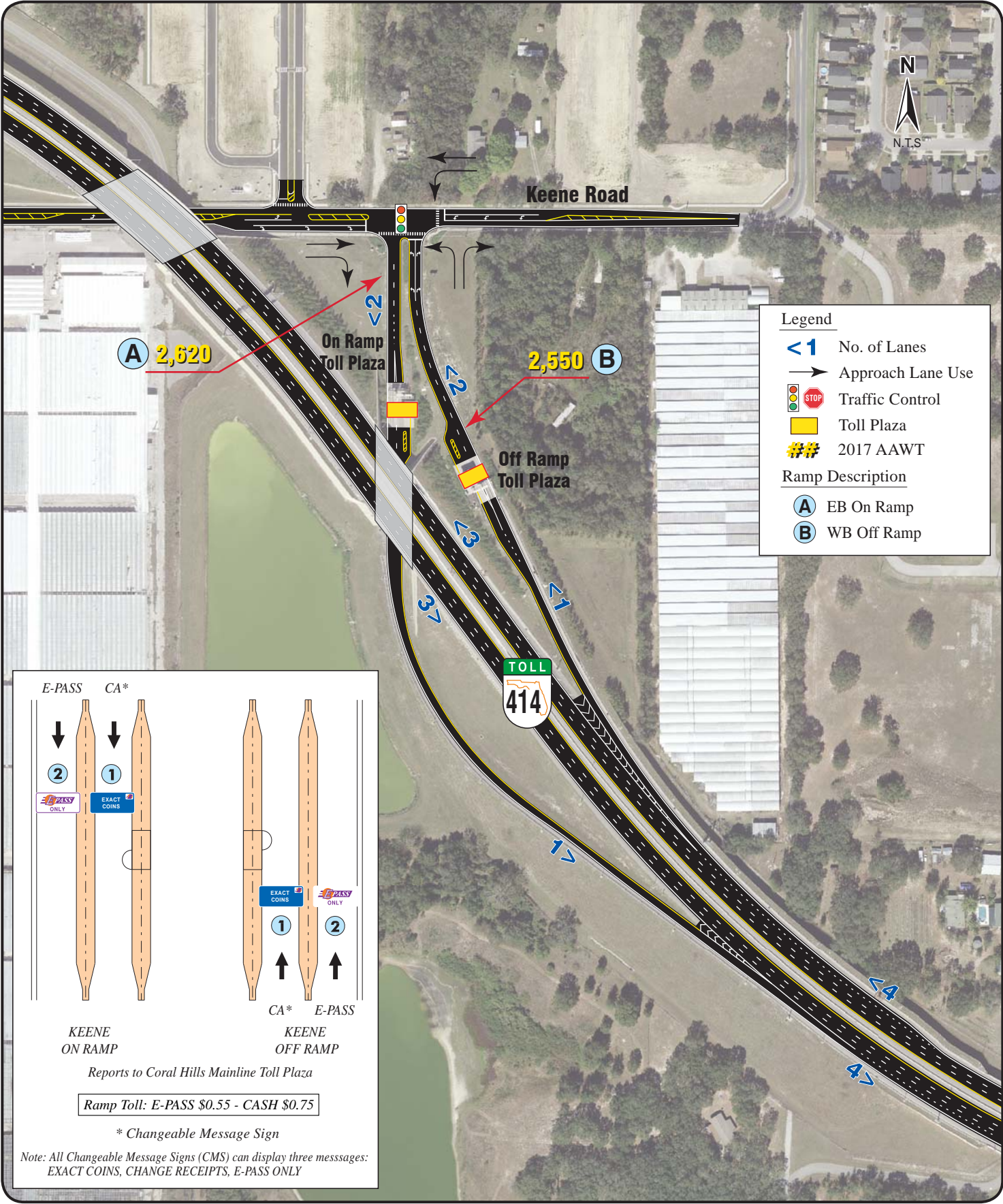

Legend

- <1 No. of Lanes
- Approach Lane Use
- 🚦 Traffic Control
- 🟡 Toll Plaza
- ## 2017 AAWT

Ramp Description

- (A) EB On Ramp
- (B) WB Off Ramp

E-PASS CA*

KEENE ON RAMP
Reports to Coral Hills Mainline Toll Plaza

KEENE OFF RAMP

Ramp Toll: E-PASS \$0.55 - CASH \$0.75

* Changeable Message Sign

Note: All Changeable Message Signs (CMS) can display three messages: EXACT COINS, CHANGE RECEIPTS, E-PASS ONLY

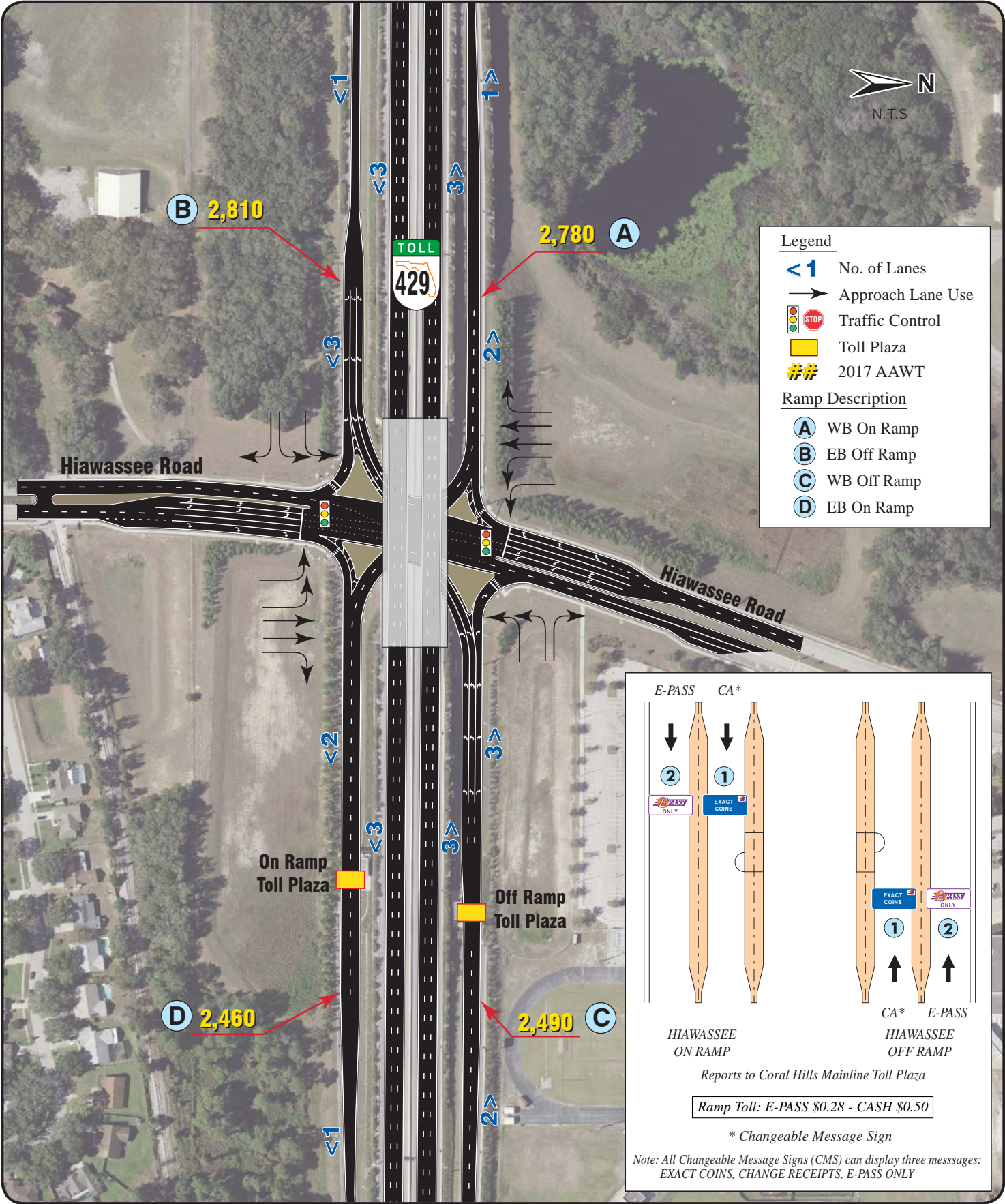

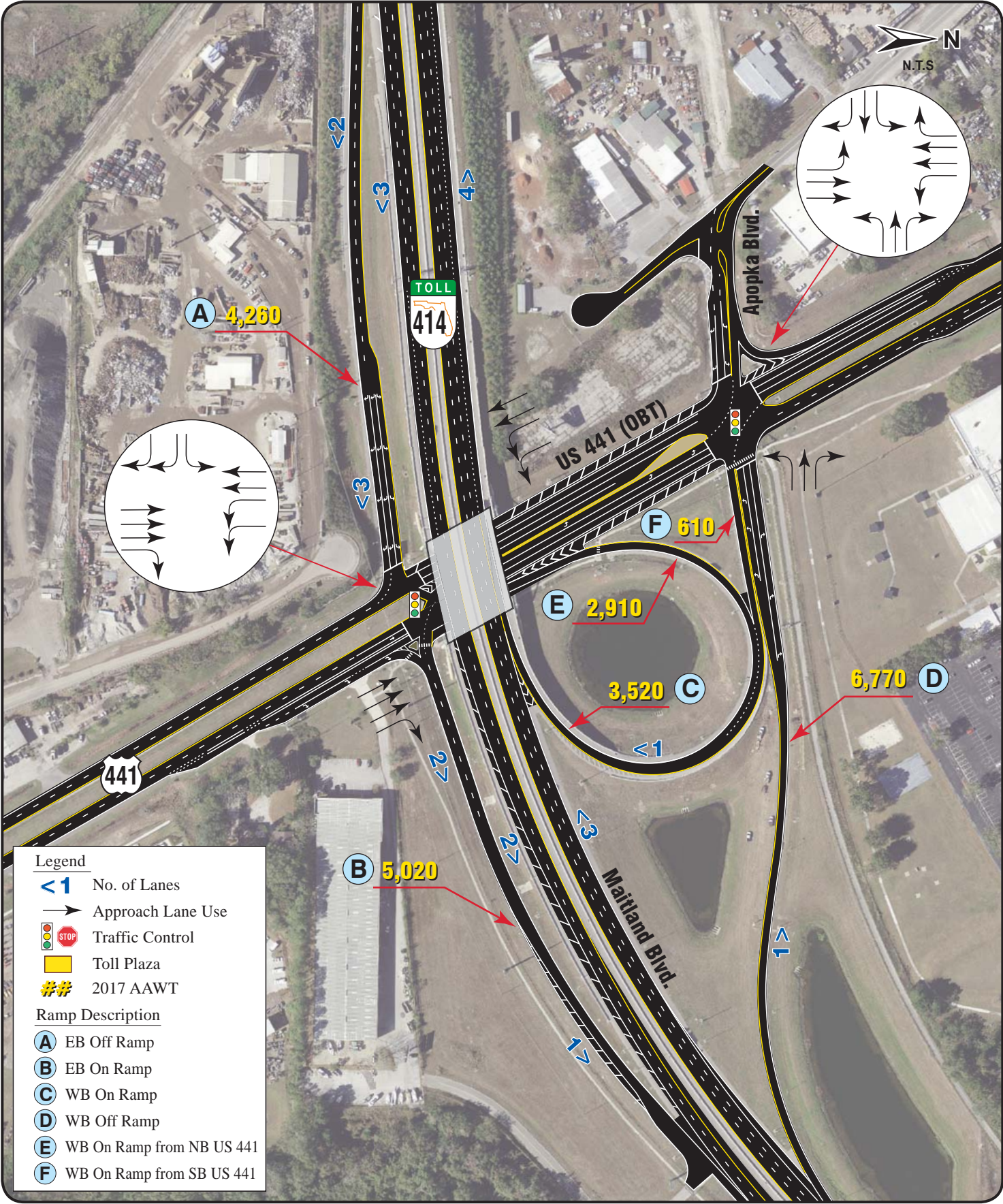

Legend

- <1 No. of Lanes
- Approach Lane Use
- 🚦 Traffic Control
- 🛑 STOP
- 🟡 Toll Plaza
- ## 2017 AAWT

Ramp Description

- Ⓐ EB Off Ramp
- Ⓑ EB On Ramp
- Ⓒ WB On Ramp
- Ⓓ WB Off Ramp
- Ⓔ WB On Ramp from NB US 441
- Ⓕ WB On Ramp from SB US 441



**SR 414 (APOPKA EXPRESSWAY)
Exit 9 - Orange Blossom Trail (US 441)**

SECTION IV

273

Western Beltway Connector Road



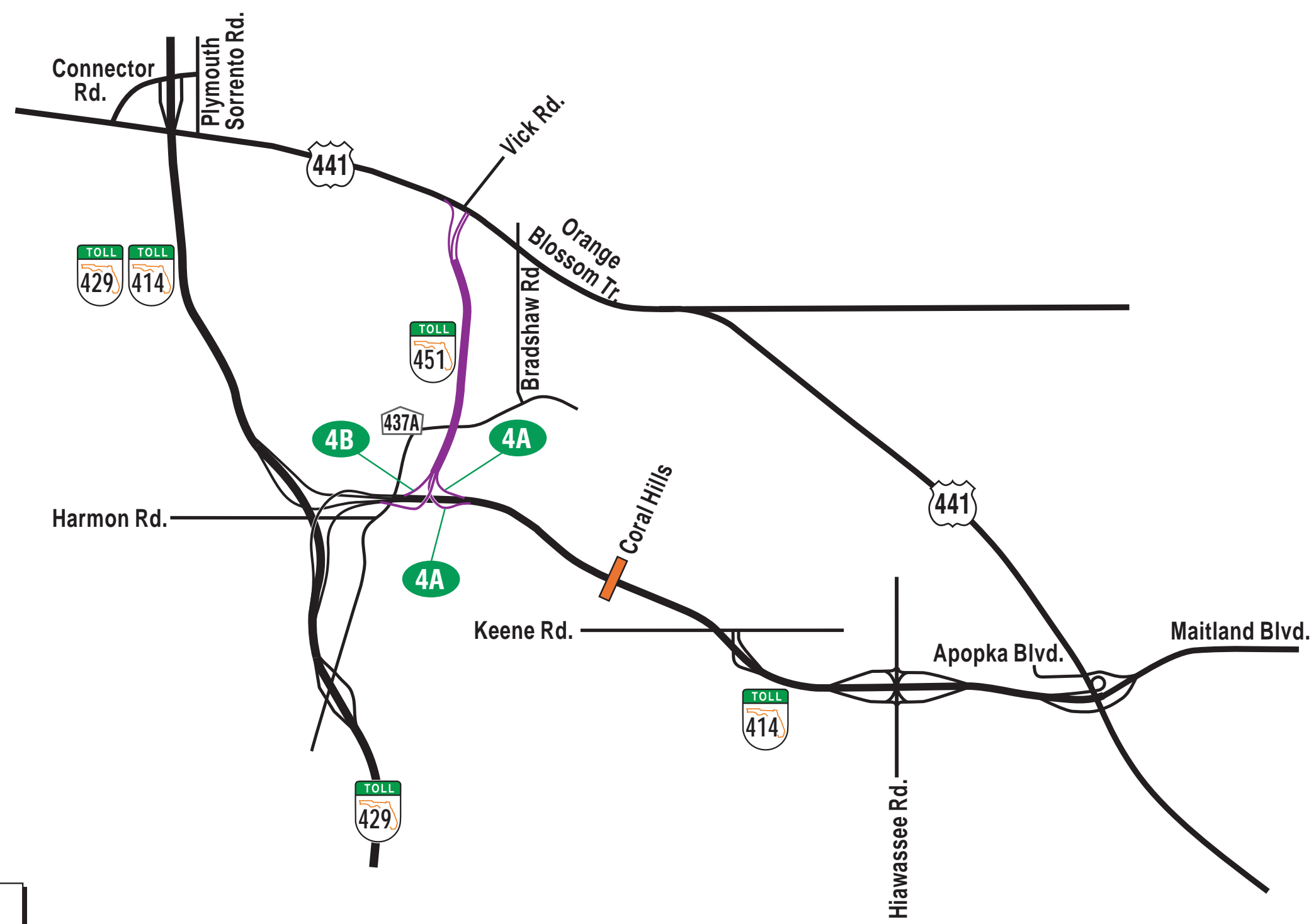



LEGEND

- Exit Number
- Existing SR 451
- Mainline Toll Plaza



SR 451 - WESTERN BELTWAY CONNECTOR ROAD
Exit Numbers

Legend

- < 1** No. of Lanes
- Approach Lane Use
-  Traffic Control
-  Toll Plaza
- ##** 2017 AAWT

Ramp Description

- (A)** SB Off Ramp to EB SR 414
- (B)** NB On Ramp from SR 429
- (C)** SB Off to SR 429
- (D)** NB On from WB SR 414
- (E)** EB On Ramp from NB SR 429
- (F)** WB Off Ramp to SB SR 429

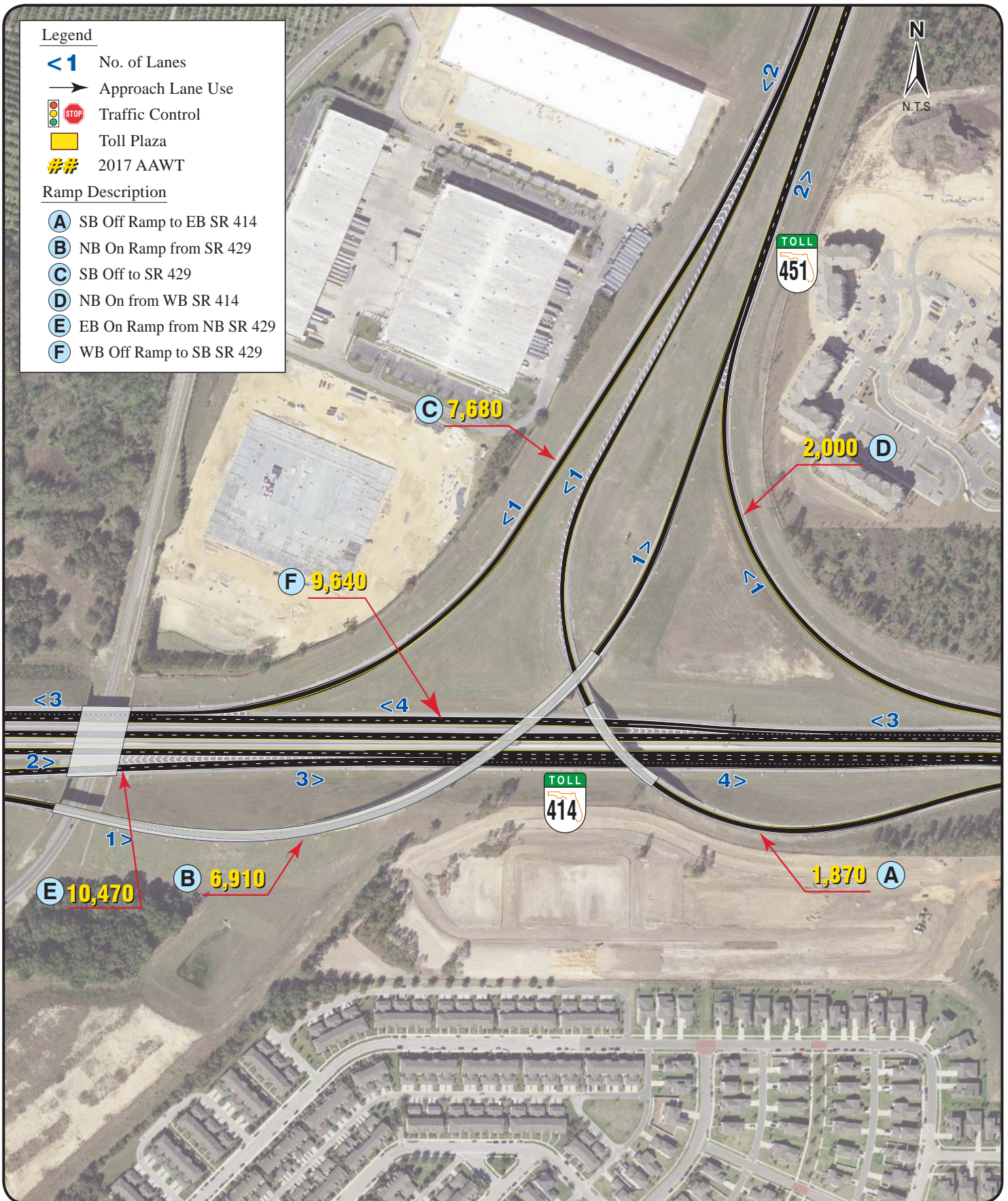



Legend

- <1> No. of Lanes
- Approach Lane Use
- Traffic Control
- Toll Plaza
- ## 2017 AAWT

Ramp Description

- A SB On Ramp/SB 441
- B NB Off Ramp
- C SB On Ramp/NB 441



Section V: General Statistics



2017 Traffic Data and Statistics Manual
CENTRAL FLORIDA EXPRESSWAY AUTHORITY

General Statistics Introduction

This section of the manual gives a summary of the general statistics that have been gathered on the Central Florida Expressway Authority's expressway system. Data is included for SR 408 (East West Expressway), SR 528 (Beachline Expressway), SR 417 (Central Florida GreeneWay), SR 429 (Daniel Webster Western Beltway and Wekiva Parkway), SR 451 (Western Connector), SR 414 (Apopka Expressway), SR 453, and the non-system Goldenrod Extension. The information contained in this section is shown below:

- Expressway Total Centerline Mileage and Total Lane Miles for SR 408, SR 528, SR 417, SR 429, SR 451, SR 414, SR 453 and the Goldenrod Extension.
- Toll Plaza Lane Summary for SR 408, SR 528, SR 417, SR 429, SR 414 and the Goldenrod Extension.
- Toll Rate Schedule for all mainline and ramp toll plazas based on the number of axles.
- Distance between interchanges for SR 408, SR 528, SR 417, SR 429, and SR 414. (Centerline of Crossroad to Centerline of Crossroad)
- Toll Rates and/or Toll Costs between interchanges on SR 408, SR 528, SR 417, SR 429, and SR 414.
- Toll Cost per Mile between interchanges on SR 408, SR 528, SR 417, SR 429, and SR 414.

SR 451 is not included in the distance between interchanges, toll rates between interchanges and toll cost per mile between interchanges due to this expressway portion not containing any mainline toll plazas and ramp toll plazas. SR 453 and Wekiva Phase II were opened to traffic on March 31, 2018 and are included for informational purposes.

Expressway Mileage, Lane Miles, Toll Plaza Lanes and Toll Rate Schedules



2017 Traffic Data and Statistics Manual
CENTRAL FLORIDA EXPRESSWAY AUTHORITY

Central Florida Expressway Authority (CFX)

Expressway Mileage

CFX Expressway Facility	Rounded Miles	Total Length ⁽¹⁾	
		Miles	Kilometers
Central Florida Expressway System			
SR 408 (East-West Expressway)	22	21.477	34.564
SR 528 (Beachline Expressway)	23	22.405	36.057
SR 417 (Central Florida GreeneWay)	32	31.613	50.876
SR 429 (Western Beltway and Wekiva Parkway)	31	30.848	49.645
SR 451 (Western Beltway Connector Rd) ⁽²⁾	2	1.670	2.688
SR 414 (Apopka Expressway)	6	6.024	9.695
SR 453	2	1.983	3.191
Total CFX System	118	116.020	186.716
Central Florida Expressway Nonsystem			
Goldenrod Extension ⁽³⁾	2	1.970	3.170

Total Lane Miles

CFX Expressway Facility	Lane Mile Summary	
	Mainline	Ramps
Central Florida Expressway System		
SR 408 (East-West Expressway)	159.433	40.146
SR 528 (Beachline Expressway)	115.481	18.693
SR 417 (Central Florida GreeneWay)	177.277	53.478
SR 429 (Western Beltway and Wekiva Parkway)	141.906	33.265
SR 451 (Western Beltway Connector Road) ⁽²⁾	7.172	0.403
SR 414 (Apopka Expressway)	40.954	17.142
SR 453 (Wekiva Parkway)	7.617	3.420
Total CFX System	649.840	166.547
Central Florida Expressway Nonsystem		
Goldenrod Extension ⁽³⁾	12.211	2.013

Notes:

1. Measured along the centerline of the expressway facilities.
2. SR 429 Western Beltway includes Wekiva Parkway Phase II (Completed March 2018). Shown for informational purposes only.
3. Goldenrod Extension is not considered part of the CFX system. Shown for informational purposes only.

Central Florida Expressway Authority (CFX)

Toll Facilities Lane Summary

CFX Expressway Facility	Number of Tolled Lanes
SR 408 (East-West Expressway)	
Hiawassee Mainline Toll Plaza	12
Good Homes Road Ramp Toll Plazas	4
Hiawassee Road Ramp Toll Plazas	4
SUBTOTAL	20
Pine Hills Mainline Toll Plaza	14
Old Winter Garden/Ortman Drive Ramp Toll Plazas	4
John Young Ramp Toll Plazas	4
Orange Blossom Trail Ramp Toll Plazas	4
SUBTOTAL	26
Conway East-West Mainline Toll Plaza	19
Mills Avenue Ramp Toll Plaza	1
Bumby Avenue Ramp Toll Plazas	4
Conway Road Ramp Toll Plazas	4
Andes Avenue - To SR 436 Ramp Toll Plaza	2
SR 436 (Semoran Boulevard) Ramp Toll Plaza	2
Yucatan Drive/SR 436 Ramp Toll Plaza	2
SUBTOTAL	34
Dean Mainline Toll Plaza	12
Dean Road Ramp Toll Plazas	4
Rouse Road Ramp Toll Plazas	4
SUBTOTAL	20
SR 408 SUBTOTAL	100
SR 528 (Beachline Expressway)	
Airport Mainline Toll Plaza ⁽¹⁾	0
Boggy Creek Road/McCoy Road	6
Conway Road/Tradeport Drive	4
SUBTOTAL	16
Beachline Mainline Toll Plaza	12
Monument Parkway / ICP Blvd Ramp Toll Plazas ⁽²⁾	4
SUB-TOTAL	16

1. Airport Mainline Toll Plaza removed in 2016

2. Removed and Replaced with Innovation Way Ramp Plazas (Opened March 2018)

Central Florida Expressway Authority (CFX)

Toll Facilities Lane Summary - Continued

CFX Expressway Facility	Number of Toll Lanes and Equipment
SR 528 (Beachline Expressway) - <i>continued</i>	
Dallas Mainline Toll Plaza	12
Dallas Boulevard Ramp Toll Plazas	4
SUBTOTAL	16
SR 528 SUBTOTAL	42
SR 417 (Central Florida GreeneWay)	
John Young Mainline Toll Plaza	12
John Young Parkway Ramp Toll Plazas	4
Orange Blossom Trail Ramp Toll Plazas	4
Landstar Boulevard Ramp Toll Plazas	4
SUBTOTAL	24
Boggy Creek Mainline Toll Plaza	14
South Access Road (Ramp Toll Plazas and Gantry)	3
Boggy Creek Road Ramp Toll Plazas	4
Lake Nona Boulevard Ramp Toll Plazas	4
Narcoossee Road Ramp Toll Plazas	4
Moss Park Road Ramp Toll Plazas	4
Innovation Way/Dowden Road Ramp Toll Plazas	4
SUBTOTAL	37
Curry Ford Mainline Toll Plazas	14
Lee Vista Boulevard Ramp Toll Plazas	4
Curry Ford Road Ramp Toll Plazas	4
SUBTOTAL	22
University Mainline Toll Plaza	12
SR 50/Colonial Drive Ramp Toll Plazas	4
University Boulevard Ramp Toll Plazas	4
SUBTOTAL	20
SR 417 SUBTOTAL	103

Central Florida Expressway Authority (CFX)

Toll Facilities Lane Summary - Continued

CFX Expressway Facility	Number of Toll Lanes and Equipment
SR 429 (Western Expressway and Wekiva Parkway)	
Forest Lake Mainline Toll Plaza	10
CR 437A (Ocoee-Apopka Road) Ramp Toll Plazas	4
West Road Ramp Toll Plazas	4
Plant St/Franklin St/SR 438 Ramp Toll Plazas	4
SUBTOTAL	22
Independence Mainline Toll Plaza	10
CR 535 (Old Winter Garden Rd) Ramp Toll Plazas	4
New Independence Parkway Ramp Toll Plazas	4
Schofield Road Ramp Toll Plazas	4
Landstar Boulevard Ramp Toll Plazas	4
SUBTOTAL	22
Ponkan Mainline Gantry ⁽²⁾	4
Mount Plymouth Mainline Gantry ⁽³⁾	4
SUBTOTAL	52
SR 414 (Apopka Expressway)	
Coral Hills Mainline Toll Plaza	12
Hiawassee Road Ramp Toll Plazas	4
Keene Road Ramp Toll Plazas	4
SUB-TOTAL	20
SR 414 SUBTOTAL	20
SR 453	
Coronado Mainline Gantry ⁽³⁾	4
SYSTEM GRAND TOTAL	321
SR 551 (Goldenrod Extension) ⁽¹⁾	
Goldenrod Mainline Toll Plaza	6

Notes:

1. Goldenrod Extension is not considered part of the CFX system. Shown for informational purposes only.
2. Ponkan Mainline Gantry opened to traffic in July of 2017
3. Coronado and Mount Plymouth opened to traffic in March of 2018

CFX Expressway	Motorcycle & 2 Axles			3 Axles			4 Axles			5 or More Axles		
	E-PASS	CASH	Pay-By-Plate ⁽⁴⁾	E-PASS	CASH	Pay-By-Plate ⁽⁴⁾	E-PASS	CASH	Pay-By-Plate ⁽⁴⁾	E-PASS	CASH	Pay-By-Plate ⁽⁴⁾
	SR 408 (East-West Expressway)											
Hiwassee Mainline Toll Plaza	\$0.82	\$1.00	NA	\$1.64	\$1.75	NA	\$1.91	\$2.00	NA	\$2.46	\$2.50	NA
Good Homes Road	\$0.28	\$0.50	NA	\$0.28	\$0.50	NA	\$0.28	\$0.50	NA	\$0.28	\$0.50	NA
Hiwassee Road	\$0.55	\$0.75	NA	\$0.55	\$0.75	NA	\$0.55	\$0.75	NA	\$0.55	\$0.75	NA
Pine Hills Mainline Toll Plaza	\$1.09	\$1.25	NA	\$1.64	\$1.75	NA	\$1.91	\$2.00	NA	\$2.46	\$2.50	NA
Old Winter Garden Road/Ottman Dr	\$0.82	\$1.00	NA	\$0.82	\$1.00	NA	\$0.82	\$1.00	NA	\$0.82	\$1.00	NA
John Young Parkway	\$0.82	\$1.00	NA	\$0.82	\$1.00	NA	\$0.82	\$1.00	NA	\$0.82	\$1.00	NA
Orange Blossom Trail	\$0.55	\$0.75	NA	\$0.55	\$0.75	NA	\$0.55	\$0.75	NA	\$0.55	\$0.75	NA
Mills Avenue	\$0.55	\$0.75	NA	\$0.55	\$0.75	NA	\$0.55	\$0.75	NA	\$0.55	\$0.75	NA
Conway East-West Mainline Toll Plaza	\$1.09	\$1.25	NA	\$1.64	\$1.75	NA	\$1.91	\$2.00	NA	\$2.46	\$2.50	NA
Bumby Avenue	\$0.55	\$0.75	NA	\$0.55	\$0.75	NA	\$0.55	\$0.75	NA	\$0.55	\$0.75	NA
Conway Road	\$0.82	\$1.00	NA	\$0.82	\$1.00	NA	\$0.82	\$1.00	NA	\$0.82	\$1.00	NA
Andes Ave/SR 436 (Semoran Blvd)	\$1.09	\$1.25	NA	\$1.09	\$1.25	NA	\$1.09	\$1.25	NA	\$1.09	\$1.25	NA
SR 436 (Semoran Blvd)/Yucatan Dr	\$0.82	\$1.00	NA	\$0.82	\$1.00	NA	\$0.82	\$1.00	NA	\$0.82	\$1.00	NA
Dean Mainline Toll Plaza	\$0.82	\$1.00	NA	\$1.64	\$1.75	NA	\$1.91	\$2.00	NA	\$2.46	\$2.50	NA
Dean Road	\$0.55	\$0.75	NA	\$0.55	\$0.75	NA	\$0.55	\$0.75	NA	\$0.55	\$0.75	NA
Rouse Road	\$0.55	\$0.75	NA	\$0.55	\$0.75	NA	\$0.55	\$0.75	NA	\$0.55	\$0.75	NA
SR 528 (Beachline Expressway)												
Airport Mainline Toll Plaza	\$1.09	\$1.25	NA	\$1.09	\$1.25	NA	\$1.09	\$1.25	NA	\$1.09	\$1.25	NA
Boggy Creek Road/McCoy Road	\$1.09	\$1.25	NA	\$1.09	\$1.25	NA	\$1.09	\$1.25	NA	\$1.09	\$1.25	NA
Conway Road/Tradeport Drive	\$0.87	\$1.00	NA	\$1.71	\$1.75	NA	\$2.00	\$2.00	NA	\$2.55	\$2.75	NA
Beachline Mainline Toll Plaza ⁽¹⁾	\$0.59	\$0.75	NA	\$0.59	\$0.75	NA	\$0.59	\$0.75	NA	\$0.59	\$0.75	NA
International Corporate Park Blvd ⁽¹⁾	\$0.59	\$0.75	NA	\$0.59	\$0.75	NA	\$0.59	\$0.75	NA	\$0.59	\$0.75	NA
Dallas Mainline Toll Plaza ⁽²⁾	\$0.76	\$1.25	NA	\$1.01	\$1.50	NA	\$1.26	\$1.75	NA	\$1.26	\$1.75	NA
Dallas Boulevard	\$0.50	\$0.50	NA	\$0.50	\$0.50	NA	\$0.50	\$0.50	NA	\$0.50	\$0.50	NA

Notes:

- Incremental increase due to the CFX July 2012 toll rate adjustment is applied at the Beachline Main Plaza and ICF Blvd ramps to preserve toll equity along the SR 528.
- Toll rates shown for the Dallas Mainline Toll Plaza include a \$0.26 EPASS and \$0.50 Cash toll charge regardless of the number of axles that is allocated to the FDOT.
- Airport Mainline Toll is collected at Turnpike Beachline West Mainline Toll Plaza
- FDOT toll increase of \$0.25 for cash payment at Dallas Mainline Toll Plaza October 2017
- Added Mount Plymouth and Coronado Toll Gantries for the opening of SR 429 Wekiva Parkway Section B and SR 453 (March 2018)
- Pay by Plate invoices for tolling points noted with a NA include the cash rate plus \$0.20 fee



Toll Rate Schedule

CFX Expressway	Motorcycle & 2 Axles			3 Axles			4 Axles			5 or More Axles		
	E-PASS	CASH	Pay-By-Plate(4)	E-PASS	CASH	Pay-By-Plate(4)	E-PASS	CASH	Pay-By-Plate(4)	E-PASS	CASH	Pay-By-Plate(4)
	SR 417 (Central Florida GreeneWay)											
John Young Mainline Toll Plaza	\$1.37	\$1.50	NA	\$1.91	\$2.00	NA	\$2.46	\$2.50	NA	\$3.00	\$3.00	NA
John Young Parkway	\$0.82	\$1.00	NA	\$0.82	\$1.00	NA	\$0.82	\$1.00	NA	\$0.82	\$1.00	NA
Orange Blossom Trail	\$0.55	\$0.75	NA	\$0.55	\$0.75	NA	\$0.55	\$0.75	NA	\$0.55	\$0.75	NA
Landstar Boulevard	\$0.50	\$0.50	NA	\$0.50	\$0.50	NA	\$0.50	\$0.50	NA	\$0.50	\$0.50	NA
Boggy Creek Mainline Toll Plaza	\$1.37	\$1.50	NA	\$1.91	\$2.00	NA	\$2.46	\$2.50	NA	\$3.00	\$3.00	NA
South Access Rd/Int'l Airport	\$1.09	\$1.25	NA	\$1.09	\$1.25	NA	\$1.09	\$1.25	NA	\$1.09	\$1.25	NA
Boggy Creek Road	\$1.09	\$1.25	NA	\$1.09	\$1.25	NA	\$1.09	\$1.25	NA	\$1.09	\$1.25	NA
Lake Nona Boulevard	\$0.82	\$1.00	NA	\$0.82	\$1.00	NA	\$0.82	\$1.00	NA	\$0.82	\$1.00	NA
Narcoossee Road	\$0.82	\$1.00	NA	\$0.82	\$1.00	NA	\$0.82	\$1.00	NA	\$0.82	\$1.00	NA
Moss Park Road	\$0.55	\$0.75	NA	\$0.55	\$0.75	NA	\$0.55	\$0.75	NA	\$0.55	\$0.75	NA
Innovation Way/Dowden Road	\$0.55	\$0.75	NA	\$0.55	\$0.75	NA	\$0.55	\$0.75	NA	\$0.55	\$0.75	NA
Curry Ford Mainline Toll Plaza	\$0.82	\$1.00	NA	\$1.64	\$1.75	NA	\$1.91	\$2.00	NA	\$2.46	\$2.50	NA
Lee Vista Boulevard	\$0.55	\$0.75	NA	\$0.55	\$0.75	NA	\$0.55	\$0.75	NA	\$0.55	\$0.75	NA
Curry Ford Road	\$0.55	\$0.75	NA	\$0.55	\$0.75	NA	\$0.55	\$0.75	NA	\$0.55	\$0.75	NA
University Mainline Toll Plaza	\$0.82	\$1.00	NA	\$1.64	\$1.75	NA	\$1.91	\$2.00	NA	\$2.46	\$2.50	NA
SR 50 (Colonial Drive)	\$0.55	\$0.75	NA	\$0.55	\$0.75	NA	\$0.55	\$0.75	NA	\$0.55	\$0.75	NA
University Boulevard	\$0.55	\$0.75	NA	\$0.55	\$0.75	NA	\$0.55	\$0.75	NA	\$0.55	\$0.75	NA
SR 429 (Western Beltway and Wekiva Parkway)												
Forest Lake Mainline Toll Plaza	\$1.37	\$1.50	NA	\$1.91	\$2.00	NA	\$2.46	\$2.50	NA	\$3.00	\$3.00	NA
CR 437A (Ocoee-Apopka Road)	\$0.55	\$0.75	NA	\$0.55	\$0.75	NA	\$0.55	\$0.75	NA	\$0.55	\$0.75	NA
West Road	\$0.82	\$1.00	NA	\$0.82	\$1.00	NA	\$0.82	\$1.00	NA	\$0.82	\$1.00	NA
Plant Street/Franklin Street/SR 438	\$0.28	\$0.50	NA	\$0.28	\$0.50	NA	\$0.28	\$0.50	NA	\$0.28	\$0.50	NA

Notes:

1. Incremental increase due to the CFX July 2012 toll rate adjustment is applied at the Beachline Main Plaza and ICP Blvd ramps to preserve toll equity along the SR 528.
2. Toll rates shown for the Dallas Mainline Toll Plaza include a \$0.26 EPASS and \$0.50 Cash toll charge regardless of the number of axles that is allocated to the FDOT.
3. Airport Mainline Toll is collected at Turnpike Beachline West Mainline Toll Plaza
4. FDOT toll increase of \$0.25 for cash payment at Dallas Mainline Toll Plaza October 2017
5. Added Mount Plymouth and Coronado Toll Gantries for the opening of SR 429 Wekiva Parkway Section B and SR 453 (March 2018)
6. Pay by Plate invoices for tolling points noted with a NA include the cash rate plus \$0.20 fee



Toll Rate Schedule

CFX Expressway	Motorcycle & 2 Axles			3 Axles			4 Axles			5 or More Axles		
	E-PASS	CASH	Pay-By-Plate(4)	E-PASS	CASH	Pay-By-Plate(4)	E-PASS	CASH	Pay-By-Plate(4)	E-PASS	CASH	Pay-By-Plate(4)
	SR 429 (Western Beltway) - Continued											
Independence Mainline Toll Plaza	\$1.37	\$1.50	NA	\$1.91	\$2.00	NA	\$2.46	\$2.50	NA	\$3.00	\$3.00	NA
CR 535	\$0.55	\$0.75	NA	\$0.55	\$0.75	NA	\$0.55	\$0.75	NA	\$0.55	\$0.75	NA
New Independence Parkway	\$0.82	\$1.00	NA	\$0.82	\$1.00	NA	\$0.82	\$1.00	NA	\$0.82	\$1.00	NA
Schofield Road	\$0.55	\$0.75	NA	\$0.55	\$0.75	NA	\$0.55	\$0.75	NA	\$0.55	\$0.75	NA
Ponkan Mainline Toll Plaza	\$0.80	NA	\$1.39	\$1.20	NA	\$1.79	\$1.60	NA	\$2.19	\$2.00	NA	\$2.59
Mount Plymouth Mainline Toll Plaza	\$0.75	NA	\$1.34	\$1.13	NA	\$1.72	\$1.50	NA	\$2.09	\$1.88	NA	\$2.47
SR 453												
Coronado Mainline Gantry	\$0.65	NA	\$1.24	\$0.98	NA	\$1.57	\$1.30	NA	\$1.89	\$1.63	NA	\$2.22
SR 414 (Apopka Expressway)												
Coral Hills Mainline Toll Plaza	\$1.09	\$1.25	NA	\$1.64	\$1.75	NA	\$2.18	\$2.25	NA	\$2.73	\$2.75	NA
Keene Road	\$0.55	\$0.75	NA	\$0.55	\$0.75	NA	\$0.55	\$0.75	NA	\$0.55	\$0.75	NA
Hiwassee Road	\$0.28	\$0.50	NA	\$0.28	\$0.50	NA	\$0.28	\$0.50	NA	\$0.28	\$0.50	NA
Goldenrod Road Extension - Non System												
Goldenrod Mainline Toll Plaza	\$0.50	\$0.50	\$0.70	\$0.50	\$0.50	\$0.70	\$0.50	\$0.50	\$0.70	\$0.50	\$0.50	\$0.70

Notes:

1. Incremental increase due to the CFX July 2012 toll rate adjustment is applied at the Beachline Main Plaza and ICP Blvd ramps to preserve toll equity along the SR 528.
2. Toll rates shown for the Dallas Mainline Toll Plaza include a \$0.26 EPASS and \$0.50 Cash toll charge regardless of the number of axles that is allocated to the FDOT.
3. Airport Mainline Toll is collected at Turnpike Beachline West Mainline Toll Plaza
4. FDOT toll increase of \$0.25 for cash payment at Dallas Mainline Toll Plaza October 2017
5. Added Mount Plymouth and Coronado Toll Gantries for the opening of SR 429 Wekiva Parkway Section B and SR 453 (March 2018)
6. Pay by Plate invoices for tolling points noted with a NA include the cash rate plus \$0.20 fee



Toll Rate Schedule

Distance Between Interchanges



2017 Traffic Data and Statistics Manual
CENTRAL FLORIDA EXPRESSWAY AUTHORITY

Distance From	Distance To				
	Florida Turnpike	SR 50/Clarke Road	Good Homes Road	Hiwassee Road	Kirkman Road
	Distance (miles)	Distance (miles)	Distance (miles)	Distance (miles)	Distance (miles)
Florida's Turnpike	-----	-----	1.556	3.336	4.493
SR 50/Clarke Road	-----	-----	0.705	2.485	3.642
Good Homes Road	1.556	0.705	-----	1.780	2.937
Hiwassee Road	3.336	2.485	1.780	-----	1.157
Kirkman Road	4.493	3.642	2.937	1.157	-----
Pine Hills Road	-----	-----	-----	-----	-----
Old Winter Garden/Mercy-Ortman Dr	-----	-----	-----	-----	-----
John Young Parkway	7.252	6.401	5.696	3.916	2.759
Tampa Avenue	7.916	7.065	6.360	4.580	3.423
Orange Blossom Trail	8.430	7.579	6.874	5.094	3.937
Interstate 4 (I-4)	9.000	8.149	7.444	5.664	4.507
Orange Avenue	9.592	8.741	8.036	6.256	5.099
Rosalind Avenue	-----	-----	-----	-----	-----
Mills Avenue	-----	-----	-----	-----	-----
Bumby Avenue	11.216	10.365	9.660	7.880	6.723
Crystal Lake Drive	-----	-----	-----	-----	-----
Conway Road	12.466	11.615	10.910	9.130	7.973
Andes Avenue	13.208	12.357	11.652	9.872	8.715
Semorán Blvd (SR 436)	13.738	12.887	12.182	10.402	9.245
Yucatan Drive	-----	-----	-----	-----	-----
Goldenrod Road	15.257	14.406	13.701	11.921	10.764
Chickasaw Trail	15.826	14.975	14.270	12.490	11.333
SR 417 (GreeneWay)	17.215	16.364	15.659	13.879	12.722
Dean Road	18.042	17.191	16.486	14.706	13.549
Rouse Road	19.314	18.463	17.758	15.978	14.821
Alafaya Trail	20.518	19.667	18.962	17.182	16.025
SR 50 (East Colonial Dr)	22.209	21.358	20.653	18.873	17.716



SR 408 (East-West Expressway) Distance Between Interchanges (Miles)

Distance From	Distance To				
	Pine Hills Road	OWG/Mercy/Ortman	John Young Parkway	Tampa Avenue	Orange Blossom Trail
	Distance (miles)	Distance (miles)	Distance (miles)	Distance (miles)	Distance (miles)
Florida's Turnpike	-----	-----	7.252	7.916	8.430
SR 50/Clarke Road	-----	-----	6.401	7.065	7.579
Good Homes Road	-----	-----	5.696	6.360	6.874
Hiwassee Road	-----	-----	3.916	4.580	5.094
Kirkman Road	-----	-----	2.759	3.423	3.937
Pine Hills Road	-----	-----	2.169	2.833	3.346
Old Winter Garden/Mercy-Ortman Dr	-----	-----	1.078	1.742	2.256
John Young Parkway	2.169	1.078	-----	0.664	1.178
Tampa Avenue	2.833	1.742	0.664	-----	-----
Orange Blossom Trail	3.346	2.256	1.178	-----	-----
Interstate 4 (I-4)	3.916	2.826	1.748	-----	0.570
Orange Avenue	4.509	3.418	2.340	-----	1.163
Rosalind Avenue	-----	-----	-----	-----	-----
Mills Avenue	-----	-----	-----	-----	-----
Bumby Avenue	6.133	5.042	3.964	-----	2.787
Crystal Lake Drive	-----	-----	-----	-----	-----
Conway Road	7.383	6.292	5.214	-----	4.037
Andes Avenue	8.125	7.034	5.956	-----	4.779
Semorán Blvd (SR 436)	8.655	7.564	6.486	-----	5.309
Yucatan Drive	-----	-----	-----	-----	-----
Goldenrod Road	10.174	9.083	8.005	-----	6.828
Chickasaw Trail	10.743	9.652	8.574	-----	7.397
SR 417 (GreeneWay)	12.132	11.041	9.963	-----	8.786
Dean Road	12.959	11.868	10.790	-----	9.613
Rouse Road	14.231	13.140	12.062	-----	10.885
Alafaya Trail	15.435	14.344	13.266	-----	12.089
SR 50 (East Colonial Dr)	17.126	16.035	14.957	-----	13.780



SR 408 (East-West Expressway) Distance Between Interchanges (Miles) - Continued

Distance From	Distance To				
	Interstate 4 (I-4)	Orange Avenue	Rosalind Avenue	Mills Avenue	Bumby Avenue
	Distance (miles)	Distance (miles)	Distance (miles)	Distance (miles)	Distance (miles)
Florida's Turnpike	9.000	9.592	-----	10.455	11.216
SR 50/Clarke Road	8.149	8.741	-----	9.604	10.365
Good Homes Road	7.444	8.036	-----	8.899	9.660
Hiwassee Road	5.664	6.256	-----	7.119	7.880
Kirkman Road	4.507	5.099	-----	5.962	6.723
Pine Hills Road	3.916	4.509	-----	5.372	6.133
Old Winter Garden/Mercy-Ortman Dr	2.826	3.418	-----	4.281	5.042
John Young Parkway	1.748	2.340	-----	3.203	3.964
Tampa Avenue	-----	-----	-----	-----	-----
Orange Blossom Trail	0.570	1.163	-----	2.026	2.787
Interstate 4 (I-4)	-----	0.592	-----	1.456	2.217
Orange Avenue	-----	-----	-----	-----	-----
Rosalind Avenue	-----	-----	-----	0.583	1.344
Mills Avenue	-----	-----	-----	-----	0.761
Bumby Avenue	2.217	-----	1.344	0.761	-----
Crystal Lake Drive	-----	-----	-----	-----	-----
Conway Road	3.467	-----	2.594	2.011	-----
Andes Avenue	4.209	-----	3.336	2.753	-----
Semorán Blvd (SR 436)	4.739	-----	3.866	3.283	-----
Yucatan Drive	-----	-----	-----	-----	-----
Goldenrod Road	6.258	-----	5.385	4.802	-----
Chickasaw Trail	6.827	-----	5.954	5.371	-----
SR 417 (GreeneWay)	8.216	-----	7.343	6.760	-----
Dean Road	9.043	-----	8.170	7.587	-----
Rouse Road	10.315	-----	9.442	8.859	-----
Alafaya Trail	11.519	-----	10.646	10.063	-----
SR 50 (East Colonial Dr)	13.210	-----	12.337	11.754	-----

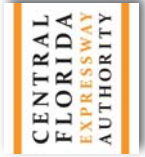

Distance From	Distance To							
	Crystal Lake Drive	Conway Road	Andes Avenue	Semorran Blvd	Yucatan Drive	Goldenrod Road		
	Distance (miles)	Distance (miles)	Distance (miles)	Distance (miles)	Distance (miles)	Distance (miles)		
Florida's Turnpike	-----	12.466	13.208	-----	-----	15.257		
SR 50/Clarke Road	-----	11.615	12.357	-----	-----	14.406		
Good Homes Road	-----	10.910	11.652	-----	-----	13.701		
Hiwassee Road	-----	9.130	9.872	-----	-----	11.921		
Kirkman Road	-----	7.973	8.715	-----	-----	10.764		
Pine Hills Road	-----	7.383	8.125	-----	-----	10.174		
Old Winter Garden/Mercy-Ortman Dr	-----	6.292	7.034	-----	-----	9.083		
John Young Parkway	-----	5.214	5.956	-----	-----	8.005		
Tampa Avenue	-----	-----	-----	-----	-----	-----		
Orange Blossom Trail	-----	4.037	4.779	-----	-----	6.828		
Interstate 4 (I-4)	-----	3.467	4.209	-----	-----	6.258		
Orange Avenue	-----	2.874	3.616	-----	-----	5.665		
Rosalind Avenue	-----	2.594	3.336	-----	-----	5.385		
Mills Avenue	-----	2.011	2.753	-----	-----	4.802		
Bumby Avenue	-----	-----	-----	-----	-----	-----		
Crystal Lake Drive	-----	0.630	1.372	-----	-----	3.421		
Conway Road	0.630	-----	-----	-----	-----	-----		
Andes Avenue	1.372	-----	-----	-----	-----	-----		
Semorran Blvd (SR 436)	1.902	-----	-----	-----	-----	-----		
Yucatan Drive	-----	-----	-----	-----	-----	1.240		
Goldenrod Road	3.421	-----	-----	1.519	-----	-----		
Chickasaw Trail	3.990	-----	-----	2.088	-----	-----		
SR 417 (GreeneWay)	5.379	-----	-----	3.477	-----	1.958		
Dean Road	6.206	-----	-----	4.304	-----	2.785		
Rouse Road	7.478	-----	-----	5.576	-----	4.057		
Alafaya Trail	8.682	-----	-----	6.780	-----	5.261		
SR 50 (East Colonial Dr)	10.373	-----	-----	8.471	-----	6.952		

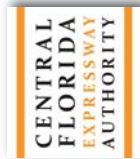

SR 408 (East-West Expressway) Distance Between Interchanges (Miles) - Continued

Distance From	Distance To							
	Chickasaw Trail	SR 417 (GreeneWay)	Dean Road	Rouse Road	Alafaya Trail	SR 50 (Colonial Dr.)		
	Distance (miles)	Distance (miles)	Distance (miles)	Distance (miles)	Distance (miles)	Distance (miles)	Distance (miles)	Distance (miles)
Florida's Turnpike	15.826	17.215	18.042	19.314	20.518	22.209		
SR 50/Clarke Road	14.975	16.364	17.191	18.463	19.667	21.358		
Good Homes Road	14.270	15.659	16.486	17.758	18.962	20.653		
Hiwassee Road	12.490	13.879	14.706	15.978	17.182	18.873		
Kirkman Road	11.333	12.722	13.549	14.821	16.025	17.716		
Pine Hills Road	10.743	12.132	12.959	14.231	15.435	17.126		
Old Winter Garden/Mercy-Ortman Dr	9.652	11.041	11.868	13.140	14.344	16.035		
John Young Parkway	8.574	9.963	10.790	12.062	13.266	14.957		
Tampa Avenue	-----	-----	-----	-----	-----	-----		
Orange Blossom Trail	7.397	8.786	9.613	10.885	12.089	13.780		
Interstate 4 (I-4)	6.827	8.216	9.043	10.315	11.519	13.210		
Orange Avenue	-----	-----	-----	-----	-----	-----		
Rosalind Avenue	5.954	7.343	8.170	9.442	10.646	12.337		
Mills Avenue	5.371	6.760	7.587	8.859	10.063	11.754		
Bumby Avenue	-----	-----	-----	-----	-----	-----		
Crystal Lake Drive	3.990	5.379	6.206	7.478	8.682	10.373		
Conway Road	-----	-----	-----	-----	-----	-----		
Andes Avenue	-----	-----	-----	-----	-----	-----		
Semorán Blvd (SR 436)	-----	-----	-----	-----	-----	-----		
Yucatan Drive	1.809	3.198	4.025	5.297	6.501	8.192		
Goldenrod Road	-----	1.958	2.785	4.057	5.261	6.952		
Chickasaw Trail	-----	-----	-----	-----	-----	-----		
SR 417 (GreeneWay)	-----	-----	0.827	2.099	3.303	4.994		
Dean Road	-----	0.827	-----	1.272	2.476	4.167		
Rouse Road	-----	2.099	1.272	-----	1.204	2.895		
Alafaya Trail	-----	3.303	2.476	1.204	-----	-----		
SR 50 (East Colonial Dr)	-----	4.994	4.167	2.895	-----	-----		

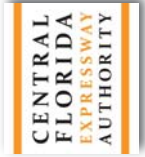

SR 408 (East-West Expressway) Distance Between Interchanges (Miles) - Continued

Distance From	Distance To				
	Boggy Creek Rd.	Tradeport/Conway	Semoran Blvd/Airport	Goldenrod Road	Narcoossee Road
	Distance (miles)	Distance (miles)	Distance (miles)	Distance (miles)	Distance (miles)
US 441/Florida Turnpike	3.580	4.657	6.157	7.520	8.875
Boggy Creek Road	-----	1.077	2.577	3.940	5.295
Tradeport Dr / Conway Rd	1.077	-----	1.501	2.863	4.218
Semoran Blvd / Airport	2.577	1.501	-----	1.363	2.718
Goldenrod Road	3.940	2.863	1.363	-----	1.355
Narcoossee Road	5.295	4.218	2.718	1.355	-----
SR 417 (GreeneWay)	7.385	6.308	4.807	3.445	2.090
Monument Pkw/ICP Blvd ⁽¹⁾	11.603	10.526	9.026	7.663	6.308
Dallas Boulevard	15.617	14.540	13.040	11.677	10.322
SR 520	22.667	21.591	20.090	18.728	17.373
Brevard County Line	27.605	26.529	25.028	23.666	22.311

Distance From	Distance To			
	SR 417 (GreeneWay)	Monuemnt Pkw/ICP ⁽¹⁾	Dallas Boulevard	SR 520
	Distance (miles)	Distance (miles)	Distance (miles)	Distance (miles)
US 441/Florida Turnpike	10.965	15.183	19.197	26.247
Boggy Creek Road	7.385	11.603	15.617	22.667
Tradeport Dr / Conway Rd	6.308	10.526	14.540	21.591
Semoran Blvd / Airport	4.807	9.026	13.040	20.090
Goldenrod Road	3.445	7.663	11.677	18.728
Narcoossee Road	2.090	6.308	10.322	17.373
SR 417 (GreeneWay)	-----	4.218	8.232	15.283
Monument Pkw/ICP Blvd ⁽¹⁾	4.218	-----	4.014	11.065
Dallas Boulevard	8.232	4.014	-----	-----
SR 520	15.283	11.065	-----	-----
Brevard County Line	20.221	16.003	-----	4.938

Notes: 1. ICP Blvd exit Removed and Replaced with Innovation Way exit (Opened March 2018)



SR 528 (Beachline Expressway) Distance Between Interchanges (Miles)

Distance From	Distance To				
	International Drive	John Young Parkway	Orange Blossom Trail	Florida Turnpike	Landstar Boulevard
	Distance (miles)	Distance (miles)	Distance (miles)	Distance (miles)	Distance (miles)
International Drive	-----	4.240	5.604	-----	7.948
John Young Parkway	4.240	-----	1.364	-----	3.707
Orange Blossom Trail	5.604	1.364	-----	0.967	2.344
Florida Turnpike	-----	-----	-----	-----	1.376
Landstar Boulevard	7.948	3.707	2.344	1.376	-----
South Access Rd (Int'l Airport)	11.475	7.234	5.871	4.903	3.527
Boggy Creek Road	11.475	7.234	5.871	4.903	3.527
Lake Nona Boulevard	13.566	9.326	7.962	6.995	5.619
Narcoossee Road	16.117	11.877	10.513	9.546	8.170
Moss Park Road	17.579	13.339	11.975	11.007	9.631
Dowden Road	18.503	14.262	12.899	11.931	10.555
SR 528 (Beachline Expwy)	20.131	15.891	14.527	13.560	12.184
Lee Vista Boulevard	22.033	17.793	16.429	15.462	14.086
Curry Ford Road	24.336	20.096	18.732	17.765	16.389
SR 408 (East-West Expwy)	27.064	22.824	21.460	20.492	19.116
SR 50 (Colonial Drive)	28.756	24.516	23.152	22.184	20.808
University Boulevard	31.024	26.784	25.420	24.452	23.076
Aloma Avenue	32.657	28.417	27.053	26.086	24.710



SR 417 (Central Florida GreeneWay) Distance Between Interchanges (Miles)

Distance From	Distance To				
	South Access (Airport)	Boggy Creek Road	Lake Nona Boulevard	Narcoossee Road	Moss Park Road
	Distance (miles)	Distance (miles)	Distance (miles)	Distance (miles)	Distance (miles)
International Drive	10.829	11.475	13.566	16.117	17.579
John Young Parkway	7.234	7.234	9.326	11.877	13.339
Orange Blossom Trail	5.871	5.871	7.962	10.513	11.975
Florida Turnpike	4.903	4.903	6.995	9.546	11.007
Landstar Boulevard	3.527	3.527	5.619	8.170	9.631
South Access Rd (Int'l Airport)	-----	-----	2.092	4.643	6.104
Boggy Creek Road	-----	-----	2.092	4.643	6.104
Lake Nona Boulevard	2.092	2.092	-----	2.551	4.013
Narcoossee Road	4.643	4.643	2.551	-----	1.462
Moss Park Road	6.104	6.104	4.013	1.462	-----
Dowden Road	7.028	7.028	4.937	2.385	0.924
SR 528 (Beachline Expwy)	8.657	8.657	6.565	4.014	2.553
Lee Vista Boulevard	10.559	10.559	8.467	5.916	4.455
Curry Ford Road	12.862	12.862	10.770	8.219	6.758
SR 408 (East-West Expwy)	15.589	15.589	13.498	10.947	9.485
SR 50 (Colonial Drive)	17.281	17.281	15.190	12.639	11.177
University Boulevard	19.549	19.549	17.458	14.907	13.445
Aloma Avenue	21.183	21.183	19.091	16.540	15.078



SR 417 (Central Florida GreeneWay) Distance Between Interchanges (Miles) - Continued

Distance From	Distance To			
	Dowden Road	SR 528 (Beachline)	Lee Vista Boulevard	Curry Ford Road
	Distance (miles)	Distance (miles)	Distance (miles)	Distance (miles)
International Drive	18.503	20.131	22.033	24.336
John Young Parkway	14.262	15.891	17.793	20.096
Orange Blossom Trail	12.899	14.527	16.429	18.732
Florida Turnpike	11.931	13.560	15.462	17.765
Landstar Boulevard	10.555	12.184	14.086	16.389
South Access Rd (Int'l Airport)	7.028	8.657	10.559	12.862
Boggy Creek Road	7.028	8.657	10.559	12.862
Lake Nona Boulevard	4.937	6.565	8.467	10.770
Narcoossee Road	2.385	4.014	5.916	8.219
Moss Park Road	0.924	2.553	4.455	6.758
Dowden Road	-----	1.629	3.531	5.834
SR 528 (Beachline Expwy)	1.629	-----	1.902	4.205
Lee Vista Boulevard	3.531	1.902	-----	2.303
Curry Ford Road	5.834	4.205	2.303	-----
SR 408 (East-West Expwy)	8.561	6.933	5.031	2.728
SR 50 (Colonial Drive)	10.253	8.625	6.723	4.420
University Boulevard	12.521	10.893	8.991	6.688
Aloma Avenue	14.155	12.526	10.624	8.321



SR 417 (Central Florida GreeneWay) Distance Between Interchanges (Miles) - Continued

Distance From	Distance To			
	SR 408 (East West)	SR 50 (Colonial Dr.)	University Boulevard	Aloma Avenue
	Distance (miles)	Distance (miles)	Distance (miles)	Distance (miles)
International Drive	27.064	28.756	31.024	32.657
John Young Parkway	22.824	24.516	26.784	28.417
Orange Blossom Trail	21.460	23.152	25.420	27.053
Florida Turnpike	20.492	22.184	24.452	26.086
Landstar Boulevard	19.116	20.808	23.076	24.710
South Access Rd (Int'l Airport)	15.589	17.281	19.549	21.183
Boggy Creek Road	15.589	17.281	19.549	21.183
Lake Nona Boulevard	13.498	15.190	17.458	19.091
Narcoossee Road	10.947	12.639	14.907	16.540
Moss Park Road	9.485	11.177	13.445	15.078
Dowden Road	8.561	10.253	12.521	14.155
SR 528 (Beachline Expwy)	6.933	8.625	10.893	12.526
Lee Vista Boulevard	5.031	6.723	8.991	10.624
Curry Ford Road	2.728	4.420	6.688	8.321
SR 408 (East-West Expwy)	-----	1.692	3.960	5.593
SR 50 (Colonial Drive)	1.692	-----	2.268	3.901
University Boulevard	3.960	2.268	-----	1.633
Aloma Avenue	5.593	3.901	1.633	-----



SR 417 (Central Florida GreeneWay) Distance Between Interchanges (Miles) - Continued

Distance From	Distance To					
	Seidel Road	Schofield Road	New Independence	CR 535	Florida Turnpike	SR 50 (Colonial Dr.)
	Distance (miles)	Distance (miles)	Distance (miles)	Distance (miles)	Distance (miles)	Distance (miles)
Seidel Road	-----	2.120	2.120	8.449	11.405	11.734
Schofield Road	2.120	-----	-----	6.329	9.285	9.615
New Independence Parkway	4.079	1.959	1.959	4.370	7.326	7.656
CR 535 (Old Winter Garden)	8.449	6.329	6.329	-----	2.956	3.286
Florida Turnpike (SR 91)	11.405	9.285	9.285	2.956	-----	-----
SR 50 (West Colonial Drive)	11.734	9.615	9.615	3.286	-----	-----
Plant St/Franklin St/SR 438	13.171	11.052	11.052	4.723	1.767	1.437
West Road	15.683	13.563	13.563	7.234	4.278	3.949
CR 437A (Ocoee Apopka Rd)	18.197	16.077	16.077	9.748	6.792	6.463
SR 414 (Apopka Expressway)	19.556	17.436	17.436	11.107	8.151	7.822
SR 429 Connector Road	22.980	20.861	20.861	14.532	11.576	11.246
Kelly Park Rd	27.044	24.925	22.966	18.596	15.640	15.310

Distance From	Distance To				
	Plant/Franklin St.	West Road	CR 437A	SR 414 (Apopka Expwy)	SR 429 Connector Rd.
	Distance (miles)	Distance (miles)	Distance (miles)	Distance (miles)	Distance (miles)
Seidel Road	13.171	15.683	18.197	19.556	22.980
Schofield Road	11.052	13.563	16.077	17.436	20.861
New Independence Parkway	9.093	11.604	14.118	15.477	18.902
CR 535 (Old Winter Garden)	4.723	7.234	9.748	11.107	14.532
Florida Turnpike (SR 91)	1.767	4.278	6.792	8.151	11.576
SR 50 (West Colonial Drive)	1.437	3.949	6.463	7.822	11.246
Plant St/Franklin St/SR 438	-----	2.512	5.026	6.385	9.809
West Road	2.512	-----	2.514	3.873	7.298
CR 437A (Ocoee Apopka Rd)	5.026	2.514	-----	1.359	4.784
SR 414 (Apopka Expressway)	6.385	3.873	1.359	-----	3.424
SR 429 Connector Road	9.809	7.298	4.784	3.424	-----
Kelly Park Rd	13.873	11.362	8.848	7.488	4.064



SR 429 (Western Beltway and Wekiva Parkway) Distance Between Interchanges (Miles)

Distance From	Distance To	
	US 441 / Vick Rd Ext.	SR 429/414 System Int
	Distance (miles)	Distance (miles)
US 441 / Vick Road Extension	----- 1.87	1.87
SR 429/414 System Interchange		-----



SR 451 (Western Beltway Connector) Distance Between Interchanges (Miles)

Distance From	Distance To					
	SR 429 Connector Rd.	SR 451	Keene Road	Hiwassee Road	OBT - US 441 (East)	Bear Lake/Rose Ave.
	Distance (miles)	Distance (miles)	Distance (miles)	Distance (miles)	Distance (miles)	Distance (miles)
SR 429 Connector Road	-----	-----	-----	7.926	9.378	10.070
SR 429/451 (Western Beltway)	-----	-----	-----	3.705	5.157	5.849
Keene Road	-----	-----	-----	1.290	2.743	3.435
Hiwassee Road (CR 435)	7.926	3.705	1.290	-----	1.453	2.145
OBT - US 441 (East)	9.378	5.157	2.743	1.453	-----	0.692
Bear Lake Rd / Rose Avenue	10.070	5.849	3.435	2.145	0.692	-----



SR 414 (Apopka Expressway) Distance Between Interchanges (Miles)

Toll Rates Between Interchanges



2017 Traffic Data and Statistics Manual
CENTRAL FLORIDA EXPRESSWAY AUTHORITY

From	To											
	Florida Turnpike		SR 50/ Clarke Road		Good Homes Road		Hiwassee Road		Kirkman Road			
	E-PASS	CASH	E-PASS	CASH	E-PASS	CASH	E-PASS	CASH	E-PASS	CASH		
Florida's Turnpike	-----	-----	-----	-----	\$0.28	\$0.50	\$0.82	\$1.00	\$0.82	\$1.00		
SR 50/Clarke Road	-----	-----	-----	-----	\$0.28	\$0.50	\$0.82	\$1.00	\$0.82	\$1.00		
Good Homes Road	\$0.28	\$0.50	\$0.28	\$0.50	-----	-----	-----	-----	\$0.82	\$1.00		
Hiwassee Road	\$0.82	\$1.00	\$0.82	\$1.00	\$0.82	\$1.00	-----	-----	\$0.55	\$0.75		
Kirkman Road	\$0.82	\$1.00	\$0.82	\$1.00	\$0.82	\$1.00	\$0.55	\$0.75	-----	-----		
Pine Hills Road	-----	-----	-----	-----	-----	-----	-----	-----	-----	-----		
Old Winter Garden/Mercy-Ortman Dr	-----	-----	-----	-----	-----	-----	-----	-----	-----	-----		
John Young Parkway	\$1.91	\$2.25	\$1.91	\$2.25	\$1.91	\$2.25	\$1.64	\$2.00	\$1.09	\$1.25		
Tampa Avenue	\$1.91	\$2.25	\$1.91	\$2.25	\$1.91	\$2.25	\$1.64	\$2.00	\$1.09	\$1.25		
Orange Blossom Trail	\$1.91	\$2.25	\$1.91	\$2.25	\$1.91	\$2.25	\$1.64	\$2.00	\$1.09	\$1.25		
Interstate 4 (I-4)	\$1.91	\$2.25	\$1.91	\$2.25	\$1.91	\$2.25	\$1.64	\$2.00	\$1.09	\$1.25		
Orange Avenue	\$1.91	\$2.25	\$1.91	\$2.25	\$1.91	\$2.25	\$1.64	\$2.00	\$1.09	\$1.25		
Rosalind Avenue	-----	-----	-----	-----	-----	-----	-----	-----	-----	-----		
Mills Avenue	-----	-----	-----	-----	-----	-----	-----	-----	-----	-----		
Bumby Avenue	\$2.46	\$3.00	\$2.46	\$3.00	\$2.46	\$3.00	\$2.19	\$2.75	\$1.64	\$2.00		
Crystal Lake Drive	-----	-----	-----	-----	-----	-----	-----	-----	-----	-----		
Conway Road	\$2.73	\$3.25	\$2.73	\$3.25	\$2.73	\$3.25	\$2.46	\$3.00	\$1.91	\$2.25		
Andes Avenue	\$3.00	\$3.50	\$3.00	\$3.50	\$3.00	\$3.50	\$2.73	\$3.25	\$2.18	\$2.50		
Semorán Blvd (SR 436)	\$3.00	\$3.50	\$3.00	\$3.50	\$3.00	\$3.50	\$2.73	\$3.25	\$2.18	\$2.50		
Yucatan Drive	-----	-----	-----	-----	-----	-----	-----	-----	-----	-----		
Goldenrod Road	\$3.00	\$3.50	\$3.00	\$3.50	\$3.00	\$3.50	\$2.73	\$3.25	\$2.18	\$2.50		
Chickasaw Trail	\$3.00	\$3.50	\$3.00	\$3.50	\$3.00	\$3.50	\$2.73	\$3.25	\$2.18	\$2.50		
SR 417 (GreeneWay)	\$3.00	\$3.50	\$3.00	\$3.50	\$3.00	\$3.50	\$2.73	\$3.25	\$2.18	\$2.50		
Dean Road	\$3.55	\$4.25	\$3.55	\$4.25	\$3.55	\$4.25	\$3.28	\$4.00	\$2.73	\$3.25		
Rouse Road	\$3.82	\$4.50	\$3.82	\$4.50	\$3.82	\$4.50	\$3.55	\$4.25	\$3.00	\$3.50		
Alafaya Trail	\$3.82	\$4.50	\$3.82	\$4.50	\$3.82	\$4.50	\$3.55	\$4.25	\$3.00	\$3.50		
SR 50 (East Colonial Dr)	\$3.82	\$4.50	\$3.82	\$4.50	\$3.82	\$4.50	\$3.55	\$4.25	\$3.00	\$3.50		



Toll Rates Between Interchanges (\$ Dollars) - 2 Axle Vehicles Only
SR 408 (East-West Expressway)

From	To											
	Pine Hills Road		OWG/Mercy/Ortman		John Young Parkway		Tampa Avenue		Orange Blossom Trail			
	E-PASS	CASH	E-PASS	CASH	E-PASS	CASH	E-PASS	CASH	E-PASS	CASH		
Florida's Turnpike	-----	-----	-----	-----	\$1.91	\$2.25	\$1.91	\$2.25	\$1.91	\$2.25	\$1.91	\$2.25
SR 50/Clarke Road	-----	-----	-----	-----	\$1.91	\$2.25	\$1.91	\$2.25	\$1.91	\$2.25	\$1.91	\$2.25
Good Homes Road	-----	-----	-----	-----	\$1.91	\$2.25	\$1.91	\$2.25	\$1.91	\$2.25	\$1.91	\$2.25
Hiwassee Road	-----	-----	-----	-----	\$1.64	\$2.00	\$1.64	\$2.00	\$1.64	\$2.00	\$1.64	\$2.00
Kirkman Road	-----	-----	-----	-----	\$1.09	\$1.25	\$1.09	\$1.25	\$1.09	\$1.25	\$1.09	\$1.25
Pine Hills Road	-----	-----	-----	-----	\$1.09	\$1.25	\$1.09	\$1.25	\$1.09	\$1.25	\$1.09	\$1.25
Old Winter Garden/Mercy-Ortman Dr	-----	-----	-----	-----	\$0.82	\$1.00	\$0.82	\$1.00	\$0.82	\$1.00	\$0.82	\$1.00
John Young Parkway	\$1.09	\$1.25	\$0.82	\$1.00	-----	-----	-----	-----	\$0.82	\$1.00	\$0.82	\$1.00
Tampa Avenue	\$1.09	\$1.25	\$0.82	\$1.00	\$0.82	\$1.00	\$0.82	\$1.00	-----	-----	-----	-----
Orange Blossom Trail	\$1.09	\$1.25	\$0.82	\$1.00	\$0.82	\$1.00	\$0.82	\$1.00	-----	-----	-----	-----
Interstate 4 (I-4)	\$1.09	\$1.25	\$0.82	\$1.00	\$0.82	\$1.00	\$0.82	\$1.00	-----	-----	-----	\$0.75
Orange Avenue	\$1.09	\$1.25	\$0.82	\$1.00	\$0.82	\$1.00	\$0.82	\$1.00	-----	-----	-----	\$0.75
Rosalind Avenue	-----	-----	-----	-----	-----	-----	-----	-----	-----	-----	-----	-----
Mills Avenue	-----	-----	-----	-----	-----	-----	-----	-----	-----	-----	-----	-----
Bumby Avenue	\$1.64	\$2.00	\$1.37	\$1.75	\$1.37	\$1.75	\$1.37	\$1.75	-----	-----	\$1.10	\$1.50
Crystal Lake Drive	-----	-----	-----	-----	-----	-----	-----	-----	-----	-----	-----	-----
Conway Road	\$1.91	\$2.25	\$1.64	\$2.00	\$1.64	\$2.00	\$1.64	\$2.00	-----	-----	\$1.37	\$1.75
Andes Avenue	\$2.18	\$2.50	\$1.91	\$2.25	\$1.91	\$2.25	\$1.91	\$2.25	-----	-----	\$1.64	\$2.00
Semorran Blvd (SR 436)	\$2.18	\$2.50	\$1.91	\$2.25	\$1.91	\$2.25	\$1.91	\$2.25	-----	-----	\$1.64	\$2.00
Yucatan Drive	-----	-----	-----	-----	-----	-----	-----	-----	-----	-----	-----	-----
Goldenrod Road	\$2.18	\$2.50	\$1.91	\$2.25	\$1.91	\$2.25	\$1.91	\$2.25	-----	-----	\$1.64	\$2.00
Chickasaw Trail	\$2.18	\$2.50	\$1.91	\$2.25	\$1.91	\$2.25	\$1.91	\$2.25	-----	-----	\$1.64	\$2.00
SR 417 (GreeneWay)	\$2.73	\$3.25	\$2.46	\$3.00	\$2.46	\$3.00	\$2.46	\$3.00	-----	-----	\$2.19	\$2.75
Dean Road	\$3.00	\$3.50	\$2.73	\$3.25	\$2.73	\$3.25	\$2.73	\$3.25	-----	-----	\$2.46	\$3.00
Rouse Road	\$3.00	\$3.50	\$2.73	\$3.25	\$2.73	\$3.25	\$2.73	\$3.25	-----	-----	\$2.46	\$3.00
Alafaya Trail	\$3.00	\$3.50	\$2.73	\$3.25	\$2.73	\$3.25	\$2.73	\$3.25	-----	-----	\$2.46	\$3.00
SR 50 (East Colonial Dr)	\$3.00	\$3.50	\$2.73	\$3.25	\$2.73	\$3.25	\$2.73	\$3.25	-----	-----	\$2.46	\$3.00

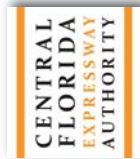

Toll Rates Between Interchanges (\$ Dollars) - 2 Axle Vehicles Only
 SR 408 (East-West Expressway) - Continued

From	To											
	Interstate 4 (I-4)		Orange Avenue		Rosalind Avenue		Mills Avenue		Bumby Avenue			
	E-PASS	CASH	E-PASS	CASH	E-PASS	CASH	E-PASS	CASH	E-PASS	CASH		
Florida's Turnpike	\$1.91	\$2.25	\$1.91	\$2.25	-----	-----	-----	\$2.46	\$2.46	\$2.46	\$3.00	
SR 50/Clarke Road	\$1.91	\$2.25	\$1.91	\$2.25	-----	-----	-----	\$2.46	\$2.46	\$2.46	\$3.00	
Good Homes Road	\$1.91	\$2.25	\$1.91	\$2.25	-----	-----	-----	\$2.46	\$2.46	\$2.46	\$3.00	
Hiwassee Road	\$1.64	\$2.00	\$1.64	\$2.00	-----	-----	-----	\$2.19	\$2.19	\$2.19	\$2.75	
Kirkman Road	\$1.09	\$1.25	\$1.09	\$1.25	-----	-----	-----	\$1.64	\$1.64	\$1.64	\$1.84	
Pine Hills Road	\$1.09	\$1.25	\$1.09	\$1.25	-----	-----	-----	\$1.64	\$1.64	\$1.64	\$1.84	
Old Winter Garden/Mercy-Ortman Dr	\$0.82	\$1.00	\$0.82	\$1.00	-----	-----	-----	\$1.37	\$1.37	\$1.37	\$1.75	
John Young Parkway	\$0.82	\$1.00	\$0.82	\$1.00	-----	-----	-----	\$1.37	\$1.37	\$1.37	\$1.75	
Tampa Avenue	-----	-----	-----	-----	-----	-----	-----	-----	-----	-----	-----	
Orange Blossom Trail	\$0.55	\$0.75	\$0.55	\$0.75	-----	-----	-----	\$1.10	\$1.10	\$1.10	\$1.50	
Interstate 4 (I-4)	-----	-----	\$0.00	\$0.00	-----	-----	-----	\$0.55	\$0.55	\$0.55	\$0.75	
Orange Avenue	-----	-----	-----	-----	-----	-----	-----	-----	-----	-----	-----	
Rosalind Avenue	-----	-----	-----	-----	-----	-----	-----	-----	-----	-----	-----	
Mills Avenue	-----	-----	-----	-----	-----	-----	-----	-----	-----	-----	-----	
Bumby Avenue	\$0.55	\$0.75	-----	-----	-----	-----	-----	\$0.55	\$0.55	\$0.55	\$0.75	
Crystal Lake Drive	-----	-----	-----	-----	-----	-----	-----	-----	-----	-----	-----	
Conway Road	\$0.82	\$1.00	-----	-----	-----	-----	-----	\$0.82	\$0.82	\$0.82	\$1.00	
Andes Avenue	\$1.09	\$1.25	-----	-----	-----	-----	-----	\$1.09	\$1.09	\$1.09	\$1.25	
Semorran Blvd (SR 436)	\$1.09	\$1.25	-----	-----	-----	-----	-----	\$1.09	\$1.09	\$1.09	\$1.25	
Yucatan Drive	-----	-----	-----	-----	-----	-----	-----	-----	-----	-----	-----	
Goldenrod Road	\$1.09	\$1.25	-----	-----	-----	-----	-----	\$1.09	\$1.09	\$1.09	\$1.25	
Chickasaw Trail	\$1.09	\$1.25	-----	-----	-----	-----	-----	\$1.09	\$1.09	\$1.09	\$1.25	
SR 417 (GreeneWay)	\$1.09	\$1.25	-----	-----	-----	-----	-----	\$1.09	\$1.09	\$1.09	\$1.25	
Dean Road	\$1.64	\$2.00	-----	-----	-----	-----	-----	\$1.64	\$1.64	\$1.64	\$2.00	
Rouse Road	\$1.91	\$2.25	-----	-----	-----	-----	-----	\$1.91	\$1.91	\$1.91	\$2.25	
Alafaya Trail	\$1.91	\$2.25	-----	-----	-----	-----	-----	\$1.91	\$1.91	\$1.91	\$2.25	
SR 50 (East Colonial Dr)	\$1.91	\$2.25	-----	-----	-----	-----	-----	\$1.91	\$1.91	\$1.91	\$2.25	



Toll Rates Between Interchanges (\$ Dollars) - 2 Axle Vehicles Only
 SR 408 (East-West Expressway) - Continued

From	To											
	Crystal Lake Drive		Conway Road		Andes Avenue		Semoran Blvd.		Yucatan Drive		Goldenrod Road	
	E-PASS	CASH	E-PASS	CASH	E-PASS	CASH	E-PASS	CASH	E-PASS	CASH	E-PASS	CASH
Florida's Turnpike	-----	-----	\$2.73	\$3.25	\$3.00	\$3.50	-----	-----	-----	-----	\$3.00	\$3.50
SR 50/Clarke Road	-----	-----	\$2.73	\$3.25	\$3.00	\$3.50	-----	-----	-----	-----	\$3.00	\$3.50
Good Homes Road	-----	-----	\$2.73	\$3.25	\$3.00	\$3.50	-----	-----	-----	-----	\$3.00	\$3.50
Hiwassee Road	-----	-----	\$2.46	\$3.00	\$2.73	\$3.25	-----	-----	-----	-----	\$2.73	\$3.25
Kirkman Road	-----	-----	\$1.91	\$2.25	\$2.18	\$2.50	-----	-----	-----	-----	\$2.18	\$2.50
Pine Hills Road	-----	-----	\$1.91	\$2.25	\$2.18	\$2.50	-----	-----	-----	-----	\$2.18	\$2.50
Old Winter Garden/Mercy-Ortman Dr	-----	-----	\$1.64	\$2.00	\$1.91	\$2.25	-----	-----	-----	-----	\$1.91	\$2.25
John Young Parkway	-----	-----	\$1.64	\$2.00	\$1.91	\$2.25	-----	-----	-----	-----	\$1.91	\$2.25
Tampa Avenue	-----	-----	-----	-----	-----	-----	-----	-----	-----	-----	-----	-----
Orange Blossom Trail	-----	-----	\$1.37	\$1.75	\$1.64	\$2.00	-----	-----	-----	-----	\$1.64	\$2.00
Interstate 4 (I-4)	-----	-----	\$0.82	\$1.00	\$1.09	\$1.25	-----	-----	-----	-----	\$1.09	\$1.25
Orange Avenue	-----	-----	\$0.82	\$1.00	\$1.09	\$1.25	-----	-----	-----	-----	\$1.09	\$1.25
Rosalind Avenue	-----	-----	\$0.82	\$1.00	\$1.09	\$1.25	-----	-----	-----	-----	\$1.09	\$1.25
Mills Avenue	-----	-----	\$0.82	\$1.00	\$1.09	\$1.25	-----	-----	-----	-----	\$1.09	\$1.25
Bumby Avenue	-----	-----	-----	-----	-----	-----	-----	-----	-----	-----	-----	-----
Crystal Lake Drive	-----	-----	\$0.82	\$1.00	\$1.09	\$1.25	-----	-----	-----	-----	\$1.09	\$1.25
Conway Road	-----	-----	-----	-----	-----	-----	-----	-----	-----	-----	-----	-----
Andes Avenue	\$0.82	\$1.00	-----	-----	-----	-----	-----	-----	-----	-----	-----	-----
Semoran Blvd (SR 436)	\$1.09	\$1.25	-----	-----	-----	-----	-----	-----	-----	-----	-----	-----
Yucatan Drive	\$1.09	\$1.25	-----	-----	-----	-----	-----	-----	-----	-----	-----	-----
Goldenrod Road	\$1.09	\$1.25	-----	-----	-----	-----	-----	-----	-----	-----	\$0.82	\$1.00
Chickasaw Trail	\$1.09	\$1.25	-----	-----	-----	-----	-----	-----	-----	-----	-----	-----
SR 417 (GreeneWay)	\$1.09	\$1.25	-----	-----	-----	-----	-----	-----	-----	-----	-----	-----
Dean Road	\$1.64	\$2.00	-----	-----	-----	-----	-----	-----	-----	-----	-----	-----
Rouse Road	\$1.91	\$2.25	-----	-----	-----	-----	-----	-----	-----	-----	-----	-----
Alafaya Trail	\$1.91	\$2.25	-----	-----	-----	-----	-----	-----	-----	-----	-----	-----
SR 50 (East Colonial Dr)	\$1.91	\$2.25	-----	-----	-----	-----	-----	-----	-----	-----	\$1.64	\$2.00



Toll Rates Between Interchanges (\$ Dollars) - 2 Axle Vehicles Only
SR 408 (East-West Expressway) - Continued

From	To													
	Chickasaw Trail		SR 417 (GreeneWay)		Dean Road		Rouse Road		Alafaya Trail		SR 50 (Colonial Dr.)			
	E-PASS	CASH	E-PASS	CASH	E-PASS	CASH	E-PASS	CASH	E-PASS	CASH	E-PASS	CASH		
Florida's Turnpike	\$3.00	\$3.50	\$3.00	\$3.50	\$3.55	\$4.25	\$3.82	\$4.50	\$3.82	\$4.50	\$3.82	\$4.50		
SR 50/Clarke Road	\$3.00	\$3.50	\$3.00	\$3.50	\$3.55	\$4.25	\$3.82	\$4.50	\$3.82	\$4.50	\$3.82	\$4.50		
Good Homes Road	\$3.00	\$3.50	\$3.00	\$3.50	\$3.55	\$4.25	\$3.82	\$4.50	\$3.82	\$4.50	\$3.82	\$4.50		
Hiwassee Road	\$2.73	\$3.25	\$2.73	\$3.25	\$3.28	\$4.00	\$3.55	\$4.25	\$3.55	\$4.25	\$3.55	\$4.25		
Kirkman Road	\$2.18	\$2.50	\$2.18	\$2.50	\$2.73	\$3.25	\$3.00	\$3.50	\$3.00	\$3.50	\$3.00	\$3.50		
Pine Hills Road	\$2.18	\$2.50	\$2.18	\$2.50	\$2.73	\$3.25	\$3.00	\$3.50	\$3.00	\$3.50	\$3.00	\$3.50		
Old Winter Garden/Mercy-Ortman Dr	\$1.91	\$2.25	\$1.91	\$2.25	\$2.46	\$3.00	\$2.73	\$3.25	\$2.73	\$3.25	\$2.73	\$3.25		
John Young Parkway	\$1.91	\$2.25	\$1.91	\$2.25	\$2.46	\$3.00	\$2.73	\$3.25	\$2.73	\$3.25	\$2.73	\$3.25		
Tampa Avenue	-----	-----	-----	-----	-----	-----	-----	-----	-----	-----	-----	-----		
Orange Blossom Trail	\$1.64	\$2.00	\$1.64	\$2.00	\$2.19	\$2.75	\$2.46	\$3.00	\$2.46	\$3.00	\$2.46	\$3.00		
Interstate 4 (I-4)	\$1.09	\$1.25	\$1.09	\$1.25	\$1.64	\$2.00	\$1.91	\$2.25	\$1.91	\$2.25	\$1.91	\$2.25		
Orange Avenue	-----	-----	-----	-----	-----	-----	-----	-----	-----	-----	-----	-----		
Rosalind Avenue	\$1.09	\$1.25	\$1.09	\$1.25	\$1.64	\$2.00	\$1.91	\$2.25	\$1.91	\$2.25	\$1.91	\$2.25		
Mills Avenue	\$1.09	\$1.25	\$1.09	\$1.25	\$1.64	\$2.00	\$1.91	\$2.25	\$1.91	\$2.25	\$1.91	\$2.25		
Bumby Avenue	-----	-----	-----	-----	-----	-----	-----	-----	-----	-----	-----	-----		
Crystal Lake Drive	\$1.09	\$1.25	\$1.09	\$1.25	\$1.64	\$2.00	\$1.91	\$2.25	\$1.91	\$2.25	\$1.91	\$2.25		
Conway Road	-----	-----	-----	-----	-----	-----	-----	-----	-----	-----	-----	-----		
Andes Avenue	-----	-----	-----	-----	-----	-----	-----	-----	-----	-----	-----	-----		
Semorran Blvd (SR 436)	-----	-----	-----	-----	-----	-----	-----	-----	-----	-----	-----	-----		
Yucatan Drive	\$0.82	\$1.00	\$0.82	\$1.00	\$1.37	\$1.75	\$1.64	\$2.00	\$1.64	\$2.00	\$1.64	\$2.00		
Goldenrod Road	-----	-----	\$0.00	\$0.00	\$0.55	\$0.75	\$0.82	\$1.00	\$0.82	\$1.00	\$0.82	\$1.00		
Chickasaw Trail	-----	-----	-----	-----	-----	-----	-----	-----	-----	-----	-----	-----		
SR 417 (GreeneWay)	-----	-----	-----	-----	\$0.55	\$0.75	\$0.82	\$1.00	\$0.82	\$1.00	\$0.82	\$1.00		
Dean Road	-----	-----	-----	-----	-----	-----	-----	-----	-----	-----	-----	-----		
Rouse Road	-----	-----	\$0.82	\$1.00	\$0.82	\$1.00	\$0.82	\$1.00	\$0.82	\$1.00	\$0.82	\$1.00		
Alafaya Trail	-----	-----	\$0.82	\$1.00	\$0.82	\$1.00	\$0.55	\$0.75	\$0.55	\$0.75	\$0.55	\$0.75		
SR 50 (East Colonial Dr)	-----	-----	\$0.82	\$1.00	\$0.82	\$1.00	\$0.55	\$0.75	-----	-----	-----	-----		



Toll Rates Between Interchanges (\$ Dollars) - 2 Axle Vehicles Only
SR 408 (East-West Expressway) - Continued

From	To									
	Boggy Creek Rd.		Tradeport/Conway		Semoran Blvd/Airport		Goldenrod Road		Narcoossee Road	
	E-PASS	CASH	E-PASS	CASH	E-PASS	CASH	E-PASS	CASH	E-PASS	CASH
US 441/Florida Turnpike	\$0.79	\$1.00	\$0.79	\$1.00	\$0.79	\$1.00	\$0.79	\$1.00	\$0.79	\$1.00
Boggy Creek Road	-----	-----	\$1.09	\$1.25	\$1.09	\$1.25	\$1.09	\$1.25	\$1.09	\$1.25
Tradeport Dr / Conway Rd	\$1.09	\$1.25	-----	-----	\$1.09	\$1.25	\$1.09	\$1.25	\$1.09	\$1.25
Semoran Blvd / Airport	\$1.09	\$1.25	\$1.09	\$1.25	-----	-----	\$0.00	\$0.00	\$0.00	\$0.00
Goldenrod Road	\$1.09	\$1.25	\$1.09	\$1.25	\$0.00	\$0.00	-----	-----	\$0.00	\$0.00
Narcoossee Road	\$1.09	\$1.25	\$1.09	\$1.25	\$0.00	\$0.00	\$0.00	\$0.00	-----	-----
SR 417 (GreeneWay)	\$1.09	\$1.25	\$1.09	\$1.25	\$0.00	\$0.00	\$0.00	\$0.00	\$0.00	\$0.00
Monument Pkwy/ICP Blvd	\$1.96	\$2.25	\$1.96	\$2.25	\$0.87	\$1.00	\$0.87	\$1.00	\$0.87	\$1.00
Dallas Boulevard	\$2.46	\$2.75	\$2.46	\$2.75	\$1.37	\$1.50	\$1.37	\$1.50	\$1.37	\$1.50
SR 520	\$2.72	\$3.25	\$2.72	\$3.25	\$1.63	\$2.00	\$1.63	\$2.00	\$1.63	\$2.00
Brevard County Line	\$2.72	\$3.25	\$2.72	\$3.25	\$1.63	\$2.00	\$1.63	\$2.00	\$1.63	\$2.00

From	To									
	SR 417 (GreeneWay)		Monument Pkwy/ICP		Dallas Boulevard		SR 520		Brevard Cty Line	
	E-PASS	CASH	E-PASS	CASH	E-PASS	CASH	E-PASS	CASH	E-PASS	CASH
US 441/Florida Turnpike	\$0.79	\$1.00	\$1.66	\$2.00	\$2.16	\$2.50	\$2.42	\$3.00	\$2.42	\$3.00
Boggy Creek Road	\$1.09	\$1.25	\$1.96	\$2.25	\$2.46	\$2.75	\$2.72	\$3.25	\$2.72	\$3.25
Tradeport Dr / Conway Rd	\$1.09	\$1.25	\$1.96	\$2.25	\$2.46	\$2.75	\$2.72	\$3.25	\$2.72	\$3.25
Semoran Blvd / Airport	\$0.00	\$0.00	\$0.87	\$1.00	\$1.37	\$1.50	\$1.63	\$2.00	\$1.63	\$2.00
Goldenrod Road	\$0.00	\$0.00	\$0.87	\$1.00	\$1.37	\$1.50	\$1.63	\$2.00	\$1.63	\$2.00
Narcoossee Road	\$0.00	\$0.00	\$0.87	\$1.00	\$1.37	\$1.50	\$1.63	\$2.00	\$1.63	\$2.00
SR 417 (GreeneWay)	-----	-----	-----	-----	-----	-----	-----	-----	-----	-----
Monument Pkwy/ICP Blvd	\$0.87	\$1.00	-----	-----	\$1.09	\$1.25	\$1.35	\$1.75	\$1.35	\$1.75
Dallas Boulevard	\$1.37	\$1.50	\$1.09	\$1.25	-----	-----	-----	-----	-----	-----
SR 520	\$1.63	\$2.00	\$1.35	\$1.75	-----	-----	-----	-----	\$0.26	\$0.50
Brevard County Line	\$1.63	\$2.00	\$1.35	\$1.75	-----	-----	\$0.26	\$0.50	-----	-----



Toll Rates Between Interchanges (\$ Dollars) - 2 Axle Vehicles Only
SR 528 (Beachline Expressway)

From	To											
	International Drive		John Young Parkway		Orange Blossom Trail		Florida Turnpike		Landstar Boulevard			
	E-PASS	CASH	E-PASS	CASH	E-PASS	CASH	E-PASS	CASH	E-PASS	CASH		
International Drive	-----	-----	\$1.37	\$1.50	\$1.37	\$1.50	\$1.37	\$1.50	\$1.37	\$1.50	\$1.87	\$2.00
John Young Parkway	\$1.37	\$1.50	-----	-----	\$0.82	\$1.00	\$0.82	\$1.00	\$0.82	\$1.00	\$1.32	\$1.50
Orange Blossom Trail	\$1.37	\$1.50	\$0.82	\$1.00	-----	-----	\$0.55	\$0.75	\$0.55	\$0.75	\$1.05	\$1.25
Florida Turnpike	\$1.37	\$1.50	\$0.82	\$1.00	\$0.55	\$0.75	-----	-----	-----	-----	\$0.50	\$0.50
Landstar Boulevard	\$1.87	\$2.00	\$1.32	\$1.50	\$1.05	\$1.25	\$0.50	\$0.50	-----	-----	-----	-----
South Access Rd (Intl Airport)	\$2.74	\$3.00	\$2.19	\$2.50	\$1.92	\$2.25	\$1.37	\$1.50	\$1.37	\$1.50	\$1.37	\$1.50
Boggy Creek Road	\$2.74	\$3.00	\$2.19	\$2.50	\$1.92	\$2.25	\$1.37	\$1.50	\$1.37	\$1.50	\$1.37	\$1.50
Lake Nona Boulevard	\$2.74	\$3.00	\$2.19	\$2.50	\$1.92	\$2.25	\$1.37	\$1.50	\$1.37	\$1.50	\$1.37	\$1.50
Narcoossee Road	\$2.74	\$3.00	\$2.19	\$2.50	\$1.92	\$2.25	\$1.37	\$1.50	\$1.37	\$1.50	\$1.37	\$1.50
Moss Park Road	\$2.74	\$3.00	\$2.19	\$2.50	\$1.92	\$2.25	\$1.37	\$1.50	\$1.37	\$1.50	\$1.37	\$1.50
Dowden Road	\$2.74	\$3.00	\$2.19	\$2.50	\$1.92	\$2.25	\$1.37	\$1.50	\$1.37	\$1.50	\$1.37	\$1.50
SR 528 (Beachline Expwy)	\$2.74	\$3.00	\$2.19	\$2.50	\$1.92	\$2.25	\$1.37	\$1.50	\$1.37	\$1.50	\$1.37	\$1.50
Lee Vista Boulevard	\$3.29	\$3.75	\$2.74	\$3.25	\$2.47	\$3.00	\$1.92	\$2.25	\$1.92	\$2.25	\$1.92	\$2.25
Curry Ford Road	\$3.56	\$4.00	\$3.01	\$3.50	\$2.74	\$3.25	\$2.19	\$2.50	\$2.19	\$2.50	\$2.19	\$2.50
SR 408 (East-West Expwy)	\$3.56	\$4.00	\$3.01	\$3.50	\$2.74	\$3.25	\$2.19	\$2.50	\$2.19	\$2.50	\$2.19	\$2.50
SR 50 (Colonial Drive)	\$4.11	\$4.75	\$3.56	\$4.25	\$3.29	\$4.00	\$2.74	\$3.25	\$2.74	\$3.25	\$2.74	\$3.25
University Boulevard	\$4.38	\$5.00	\$3.83	\$4.50	\$3.56	\$4.25	\$3.01	\$3.50	\$3.01	\$3.50	\$3.01	\$3.50
Alma Avenue	\$4.63	\$5.50	\$4.08	\$5.00	\$3.81	\$4.75	\$3.26	\$4.00	\$3.26	\$4.00	\$3.26	\$4.00



Toll Rates Between Interchanges (\$ Dollars) - 2 Axle Vehicles Only
SR 417 (Central Florida GreeneWay)

From	To											
	South Access (Airport)		Boggy Creek Road		Lake Nona Boulevard		Narcoossee Road		Moss Park Road			
	E-PASS	CASH	E-PASS	CASH	E-PASS	CASH	E-PASS	CASH	E-PASS	CASH		
International Drive	\$2.74	\$3.00	\$2.74	\$3.00	\$2.74	\$3.00	\$2.74	\$3.00	\$2.74	\$3.00		
John Young Parkway	\$2.19	\$2.50	\$2.19	\$2.50	\$2.19	\$2.50	\$2.19	\$2.50	\$2.19	\$2.50		
Orange Blossom Trail	\$1.92	\$2.25	\$1.92	\$2.25	\$1.92	\$2.25	\$1.92	\$2.25	\$1.92	\$2.25		
Florida Turnpike	\$1.92	\$2.25	\$1.92	\$2.25	\$1.92	\$2.25	\$1.92	\$2.25	\$1.92	\$2.25		
Landstar Boulevard	\$1.37	\$1.50	\$1.37	\$1.50	\$1.37	\$1.50	\$1.37	\$1.50	\$1.37	\$1.50		
South Access Rd (Intl Airport)	-----	-----	-----	-----	-----	-----	-----	-----	-----	-----		
Boggy Creek Road	-----	-----	-----	-----	-----	-----	-----	-----	-----	-----		
Lake Nona Boulevard	\$1.09	\$1.25	\$1.09	\$1.25	\$1.09	\$1.25	\$1.09	\$1.25	\$1.09	\$1.25		
Narcoossee Road	\$1.09	\$1.25	\$1.09	\$1.25	\$1.09	\$1.25	\$1.09	\$1.25	\$1.09	\$1.25		
Moss Park Road	\$1.09	\$1.25	\$1.09	\$1.25	\$1.09	\$1.25	\$1.09	\$1.25	\$1.09	\$1.25		
Dowden Road	\$1.09	\$1.25	\$1.09	\$1.25	\$1.09	\$1.25	\$1.09	\$1.25	\$1.09	\$1.25		
SR 528 (Beachline Expwy)	\$1.09	\$1.25	\$1.09	\$1.25	\$1.09	\$1.25	\$1.09	\$1.25	\$1.09	\$1.25		
Lee Vista Boulevard	\$1.64	\$2.00	\$1.64	\$2.00	\$1.64	\$2.00	\$1.64	\$2.00	\$1.64	\$2.00		
Curry Ford Road	\$1.91	\$2.25	\$1.91	\$2.25	\$1.91	\$2.25	\$1.91	\$2.25	\$1.91	\$2.25		
SR 408 (East-West Expwy)	\$1.91	\$2.25	\$1.91	\$2.25	\$1.91	\$2.25	\$1.91	\$2.25	\$1.91	\$2.25		
SR 50 (Colonial Drive)	\$2.46	\$3.00	\$2.46	\$3.00	\$2.46	\$3.00	\$2.46	\$3.00	\$2.46	\$3.00		
University Boulevard	\$2.73	\$3.25	\$2.73	\$3.25	\$2.73	\$3.25	\$2.73	\$3.25	\$2.73	\$3.25		
Alma Avenue	\$2.98	\$3.75	\$2.98	\$3.75	\$2.98	\$3.75	\$2.98	\$3.75	\$2.98	\$3.75		



Toll Rates Between Interchanges (\$ Dollars) - 2 Axle Vehicles Only
SR 417 (Central Florida GreeneWay) - Continued

From	To									
	Dowden Road		SR 528 (Beachline)		Lee Vista Boulevard		Curry Ford Road			
	E-PASS	CASH	E-PASS	CASH	E-PASS	CASH	E-PASS	CASH	E-PASS	CASH
International Drive	\$2.74	\$3.00	\$2.74	\$3.00	\$3.29	\$3.75	\$3.56	\$4.00		
John Young Parkway	\$2.19	\$2.50	\$2.19	\$2.50	\$2.74	\$3.25	\$3.01	\$3.50		
Orange Blossom Trail	\$1.92	\$2.25	\$1.92	\$2.25	\$2.47	\$3.00	\$2.74	\$3.25		
Florida Turnpike	\$1.37	\$1.50	\$1.37	\$1.50	\$1.92	\$2.25	\$2.19	\$2.50		
Landstar Boulevard	\$1.37	\$1.50	\$1.37	\$1.50	\$1.92	\$2.25	\$2.19	\$2.50		
South Access Rd (Int'l Airport)	\$1.09	\$1.25	\$1.09	\$1.25	\$1.64	\$2.00	\$1.91	\$2.25		
Boggy Creek Road	\$1.09	\$1.25	\$1.09	\$1.25	\$1.64	\$2.00	\$1.91	\$2.25		
Lake Nona Boulevard	\$0.82	\$1.00	\$0.82	\$1.00	\$1.37	\$1.75	\$1.64	\$2.00		
Narcoossee Road	\$0.82	\$1.00	\$0.82	\$1.00	\$1.37	\$1.75	\$1.64	\$2.00		
Moss Park Road	\$0.55	\$0.75	\$0.55	\$0.75	\$1.10	\$1.50	\$1.37	\$1.75		
Dowden Road	-----	-----	\$0.55	\$0.75	\$1.10	\$1.50	\$1.37	\$1.75		
SR 528 (Beachline Expwy)	\$0.55	\$0.75	-----	-----	\$0.55	\$0.75	\$0.82	\$1.00		
Lee Vista Boulevard	\$1.10	\$1.50	\$0.55	\$0.75	-----	-----	\$0.82	\$1.00		
Curry Ford Road	\$1.37	\$1.75	\$0.82	\$1.00	\$0.82	\$1.00	-----	-----		
SR 408 (East-West Expwy)	\$1.37	\$1.75	\$0.82	\$1.00	\$0.82	\$1.00	\$0.55	\$0.75		
SR 50 (Colonial Drive)	\$1.92	\$2.50	\$1.37	\$1.75	\$1.37	\$1.75	\$1.10	\$1.50		
University Boulevard	\$2.19	\$2.75	\$1.64	\$2.00	\$1.64	\$2.00	\$1.37	\$1.75		
Aloma Avenue	\$2.44	\$3.25	\$1.89	\$2.50	\$1.89	\$2.50	\$1.62	\$2.25		



Toll Rates Between Interchanges (\$ Dollars) - 2 Axle Vehicles Only
SR 417 (Central Florida GreeneWay) - Continued

From	To									
	SR 408 (East West)		SR 50 (Colonial Dr.)		University Boulevard		Aloma Avenue			
	E-PASS	CASH	E-PASS	CASH	E-PASS	CASH	E-PASS	CASH		
International Drive	\$3.56	\$4.00	\$4.11	\$4.75	\$4.38	\$5.00	\$4.63	\$5.50		
John Young Parkway	\$3.01	\$3.50	\$3.56	\$4.25	\$3.83	\$4.50	\$4.08	\$5.00		
Orange Blossom Trail	\$2.74	\$3.25	\$3.29	\$4.00	\$3.56	\$4.25	\$3.81	\$4.75		
Florida Turnpike	\$2.19	\$2.50	\$2.74	\$3.25	\$3.01	\$3.50	\$3.26	\$4.00		
Landstar Boulevard	\$2.19	\$2.50	\$2.74	\$3.25	\$3.01	\$3.50	\$3.26	\$4.00		
South Access Rd (Int'l Airport)	\$1.91	\$2.25	\$2.46	\$3.00	\$2.73	\$3.25	\$2.98	\$3.75		
Boggy Creek Road	\$1.91	\$2.25	\$2.46	\$3.00	\$2.73	\$3.25	\$2.98	\$3.75		
Lake Nona Boulevard	\$1.64	\$2.00	\$2.19	\$2.75	\$2.46	\$3.00	\$2.71	\$3.50		
Narcoossee Road	\$1.64	\$2.00	\$2.19	\$2.75	\$2.46	\$3.00	\$2.71	\$3.50		
Moss Park Road	\$1.37	\$1.75	\$1.92	\$2.50	\$2.19	\$2.75	\$2.44	\$3.25		
Dowden Road	\$1.37	\$1.75	\$1.92	\$2.50	\$2.19	\$2.75	\$2.44	\$3.25		
SR 528 (Beachline Expwy)	\$0.82	\$1.00	\$1.37	\$1.75	\$1.64	\$2.00	\$1.89	\$2.50		
Lee Vista Boulevard	\$0.82	\$1.00	\$1.37	\$1.75	\$1.64	\$2.00	\$1.89	\$2.50		
Curry Ford Road	\$0.55	\$0.75	\$1.10	\$1.50	\$1.37	\$1.75	\$1.62	\$2.25		
SR 408 (East-West Expwy)	-----	-----	\$0.55	\$0.75	\$0.82	\$1.00	\$1.07	\$1.50		
SR 50 (Colonial Drive)	\$0.55	\$0.75	-----	-----	\$0.82	\$1.00	\$1.07	\$1.50		
University Boulevard	\$0.82	\$1.00	\$0.82	\$1.00	-----	-----	\$0.80	\$1.25		
Aloma Avenue	\$1.07	\$1.50	\$1.07	\$1.50	\$0.80	\$1.25	-----	-----		



Toll Rates Between Interchanges (\$ Dollars) - 2 Axle Vehicles Only
SR 417 (Central Florida GreeneWay) - Continued

From	To											
	Seidel Road		Schofield Road		New Independence Pkwy		CR 535		Florida Turnpike		SR 50 (Colonial Dr.)	
	E-PASS	CASH	E-PASS	CASH	E-PASS	CASH	E-PASS	CASH	E-PASS	CASH	E-PASS	CASH
Seidel Road	-----	-----	\$0.55	\$0.75	\$0.82	\$1.00	\$1.37	\$1.50	\$1.37	\$1.50	\$1.37	\$1.50
Schofield Road	\$0.55	\$0.75	-----	-----	\$0.82	\$1.00	\$1.37	\$1.50	\$1.37	\$1.50	\$1.37	\$1.50
New Independence Parkway	\$0.82	\$1.00	\$0.82	\$1.00	-----	-----	\$1.37	\$1.50	-----	-----	\$0.55	\$0.75
CR 535 (Old Winter Garden)	\$1.37	\$1.50	\$1.37	\$1.50	\$1.37	\$1.50	\$1.37	\$1.50	\$0.55	\$0.75	-----	-----
Florida Turnpike (SR 91)	\$1.37	\$1.50	\$1.37	\$1.50	\$1.37	\$1.50	\$1.37	\$1.50	-----	-----	-----	-----
SR 50 (West Colonial Drive)	\$1.37	\$1.50	\$1.37	\$1.50	\$1.37	\$1.50	\$1.37	\$1.50	-----	-----	-----	-----
Plant St/Franklin St/SR 438	\$1.65	\$2.00	\$1.65	\$2.00	\$1.65	\$2.00	\$2.00	\$1.25	\$0.28	\$1.00	\$0.28	\$0.50
West Road	\$2.19	\$2.50	\$2.19	\$2.50	\$2.19	\$2.50	\$2.50	\$1.75	\$0.82	\$1.00	\$0.82	\$1.00
CR 437A (Ocoee Apopka Rd)	\$2.74	\$3.00	\$2.74	\$3.00	\$2.74	\$3.00	\$3.00	\$2.25	\$1.37	\$1.50	\$1.37	\$1.50
SR 414 (Apopka Expressway)	\$2.74	\$3.00	\$2.74	\$3.00	\$2.74	\$3.00	\$3.00	\$2.25	\$1.92	\$1.50	\$1.37	\$1.50
SR 429 Connector Road	\$2.74	\$3.00	\$2.74	\$3.00	\$2.74	\$3.00	\$3.00	\$2.25	\$1.92	\$1.50	\$1.37	\$1.50
Kelly Park Road	\$3.54	\$3.80	\$3.54	\$3.80	\$3.54	\$3.80	\$3.80	\$3.05	\$2.72	\$2.30	\$2.17	\$2.30

From	To											
	Plant/Franklin St.		West Road		CR 437A		SR 414 (Apopka Expwy)		SR 429 Connector Rd.		Kelly Park Road	
	E-PASS	CASH	E-PASS	CASH	E-PASS	CASH	E-PASS	CASH	E-PASS	CASH	E-PASS	CASH
Seidel Road	\$1.65	\$2.00	\$2.19	\$2.50	\$2.74	\$3.00	\$2.74	\$3.00	\$2.74	\$3.00	\$3.54	\$3.80
Schofield Road	\$1.65	\$2.00	\$2.19	\$2.50	\$2.74	\$3.00	\$2.74	\$3.00	\$2.74	\$3.00	\$3.54	\$3.80
New Independence Parkway	\$1.65	\$2.00	\$2.19	\$2.50	\$2.74	\$3.00	\$2.74	\$3.00	\$2.74	\$3.00	\$3.54	\$3.80
CR 535 (Old Winter Garden)	\$0.83	\$1.25	\$1.37	\$1.75	\$1.92	\$2.25	\$1.92	\$2.25	\$1.92	\$2.25	\$2.72	\$3.05
Florida Turnpike (SR 91)	\$0.28	\$0.50	\$0.82	\$1.00	\$1.37	\$1.50	\$1.37	\$1.50	\$1.37	\$1.50	\$2.17	\$2.30
SR 50 (West Colonial Drive)	\$0.28	\$0.50	\$0.82	\$1.00	\$1.37	\$1.50	\$1.37	\$1.50	\$1.37	\$1.50	\$2.17	\$2.30
Plant St/Franklin St/SR 438	-----	-----	\$0.82	\$1.00	\$1.37	\$1.50	\$1.37	\$1.50	\$1.37	\$1.50	\$2.17	\$2.30
West Road	\$0.82	\$1.00	-----	-----	\$1.37	\$1.50	\$1.37	\$1.50	\$1.37	\$1.50	\$2.17	\$2.30
CR 437A (Ocoee Apopka Rd)	\$1.37	\$1.50	\$1.37	\$1.50	-----	-----	\$0.55	\$0.75	\$0.55	\$0.75	\$1.35	\$1.55
SR 414 (Apopka Expressway)	\$1.37	\$1.50	\$1.37	\$1.50	\$0.55	\$0.75	-----	-----	\$0.00	\$0.00	\$0.80	\$0.80
SR 429 Connector Road	\$1.37	\$1.50	\$1.37	\$1.50	\$0.55	\$0.75	\$0.00	\$0.00	-----	-----	\$0.80	\$0.80
Kelly Park Road	\$2.17	\$2.30	\$2.17	\$2.30	\$1.35	\$1.55	\$0.80	\$0.80	\$0.80	\$0.80	-----	-----

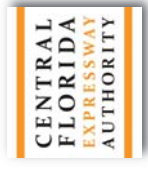

Toll Rates Between Interchanges (\$ Dollars) - 2 Axle Vehicles Only
SR 429 (Western Beltway and Wekiva Parkway)

Distance From	To											
	SR 429 Connector Rd.		SR 451		Keene Road		Hiwassee Road		OBT - US 441 (East)		Bear Lake/Rose Ave.	
	E-PASS	CASH	E-PASS	CASH	E-PASS	CASH	E-PASS	CASH	E-PASS	CASH	E-PASS	CASH
SR 429 Connector Road	-----	-----	-----	-----	-----	-----	-----	-----	-----	-----	-----	-----
SR 451 (Western Beltway)	-----	-----	-----	-----	-----	-----	-----	-----	-----	-----	-----	-----
Keene Road	-----	-----	-----	-----	-----	-----	-----	-----	-----	-----	-----	-----
Hiwassee Road (CR 435)	\$1.09	\$1.25	\$1.09	\$1.25	\$0.55	\$0.75	-----	-----	\$0.28	\$0.50	\$0.28	\$0.50
OBT - US 441 (East)	\$1.09	\$1.25	\$1.09	\$1.25	\$0.55	\$0.75	\$0.28	\$0.50	-----	-----	\$0.00	\$0.00
Bear Lake Rd / Rose Avenue	\$1.09	\$1.25	\$1.09	\$1.25	\$0.55	\$0.75	\$0.28	\$0.50	\$0.00	\$0.00	-----	-----



Toll Rates Between Interchanges (\$ Dollars) - 2 Axle Vehicles Only
SR 414 (Apopka Expressway)

Cost Per Mile Between Interchanges



2017 Traffic Data and Statistics Manual
CENTRAL FLORIDA EXPRESSWAY AUTHORITY

From	To									
	Florida Turnpike		SR 50/ Clarke Road		Good Homes Road		Hiwassee Road		Kirkman Road	
	E-PASS	CASH	E-PASS	CASH	E-PASS	CASH	E-PASS	CASH	E-PASS	CASH
Florida's Turnpike	-----	-----	-----	-----	\$0.18	\$0.32	\$0.25	\$0.30	\$0.18	\$0.22
SR 50/Clarke Road	-----	-----	-----	-----	\$0.40	\$0.71	\$0.33	\$0.40	\$0.23	\$0.27
Good Homes Road	\$0.18	\$0.32	\$0.40	\$0.71	-----	-----	\$0.46	\$0.56	\$0.28	\$0.34
Hiwassee Road	\$0.25	\$0.30	\$0.33	\$0.40	\$0.46	\$0.56	-----	-----	\$0.48	\$0.65
Kirkman Road	\$0.18	\$0.22	\$0.23	\$0.27	\$0.28	\$0.34	\$0.48	\$0.65	-----	-----
Pine Hills Road	-----	-----	-----	-----	-----	-----	-----	-----	-----	-----
Old Winter Garden/Mercy-Ortman Dr	-----	-----	-----	-----	-----	-----	-----	-----	-----	-----
John Young Parkway	\$0.26	\$0.31	\$0.30	\$0.35	\$0.34	\$0.40	\$0.42	\$0.51	\$0.40	\$0.45
Tampa Avenue	\$0.24	\$0.28	\$0.27	\$0.32	\$0.30	\$0.35	\$0.36	\$0.44	\$0.32	\$0.37
Orange Blossom Trail	\$0.23	\$0.27	\$0.25	\$0.30	\$0.28	\$0.33	\$0.32	\$0.39	\$0.28	\$0.32
Interstate 4 (I-4)	\$0.21	\$0.25	\$0.23	\$0.28	\$0.26	\$0.30	\$0.29	\$0.35	\$0.24	\$0.28
Orange Avenue	\$0.20	\$0.23	\$0.22	\$0.26	\$0.24	\$0.28	\$0.26	\$0.32	\$0.21	\$0.25
Rosalind Avenue	-----	-----	-----	-----	-----	-----	-----	-----	-----	-----
Mills Avenue	-----	-----	-----	-----	-----	-----	-----	-----	-----	-----
Bumby Avenue	\$0.22	\$0.27	\$0.24	\$0.29	\$0.25	\$0.31	\$0.28	\$0.35	\$0.24	\$0.30
Crystal Lake Drive	-----	-----	-----	-----	-----	-----	-----	-----	-----	-----
Conway Road	\$0.22	\$0.26	\$0.24	\$0.28	\$0.25	\$0.30	\$0.27	\$0.33	\$0.24	\$0.28
Andes Avenue	\$0.23	\$0.26	\$0.24	\$0.28	\$0.26	\$0.30	\$0.28	\$0.33	\$0.25	\$0.29
Semoran Blvd (SR 436)	\$0.22	\$0.25	\$0.23	\$0.27	\$0.25	\$0.29	\$0.26	\$0.31	\$0.24	\$0.27
Yucatan Drive	-----	-----	-----	-----	-----	-----	-----	-----	-----	-----
Goldenrod Road	\$0.20	\$0.23	\$0.21	\$0.24	\$0.22	\$0.26	\$0.23	\$0.27	\$0.20	\$0.23
Chickasaw Trail	\$0.19	\$0.22	\$0.20	\$0.23	\$0.21	\$0.25	\$0.22	\$0.26	\$0.19	\$0.22
SR 417 (GreeneWay)	\$0.17	\$0.20	\$0.18	\$0.21	\$0.19	\$0.22	\$0.20	\$0.23	\$0.17	\$0.20
Dean Road	\$0.20	\$0.24	\$0.21	\$0.25	\$0.22	\$0.26	\$0.22	\$0.27	\$0.20	\$0.24
Rouse Road	\$0.20	\$0.23	\$0.21	\$0.24	\$0.22	\$0.25	\$0.22	\$0.27	\$0.20	\$0.24
Alafaya Trail	\$0.19	\$0.22	\$0.19	\$0.23	\$0.20	\$0.24	\$0.21	\$0.25	\$0.19	\$0.22
SR 50 (East Colonial Dr)	\$0.17	\$0.20	\$0.18	\$0.21	\$0.18	\$0.22	\$0.19	\$0.23	\$0.17	\$0.20



Toll Rates Between Interchanges (\$ Toll Rate/Mile) - 2 Axle Vehicles Only
SR 408 (East-West Expressway)

From	To									
	Pine Hills Road		OWG/Mercy/Ortman		John Young Parkway		Tampa Avenue		Orange Blossom Trail	
	E-PASS	CASH	E-PASS	CASH	E-PASS	CASH	E-PASS	CASH	E-PASS	CASH
Florida's Turnpike	-----	-----	-----	-----	\$0.26	\$0.31	\$0.24	\$0.28	\$0.23	\$0.27
SR 50/Clarke Road	-----	-----	-----	-----	\$0.30	\$0.35	\$0.27	\$0.32	\$0.25	\$0.30
Good Homes Road	-----	-----	-----	-----	\$0.34	\$0.40	\$0.30	\$0.35	\$0.28	\$0.33
Hiwassee Road	-----	-----	-----	-----	\$0.42	\$0.51	\$0.36	\$0.44	\$0.32	\$0.39
Kirkman Road	-----	-----	-----	-----	\$0.40	\$0.45	\$0.32	\$0.37	\$0.28	\$0.32
Pine Hills Road	-----	-----	-----	-----	\$0.50	\$0.58	\$0.38	\$0.44	\$0.33	\$0.37
Old Winter Garden/Mercy-Ortman Dr	-----	-----	-----	-----	\$0.76	\$0.93	\$0.47	\$0.57	\$0.36	\$0.44
John Young Parkway	\$0.50	\$0.58	\$0.76	\$0.93	-----	-----	\$1.23	\$1.51	\$0.70	\$0.85
Tampa Avenue	\$0.38	\$0.44	\$0.47	\$0.57	\$1.23	\$1.51	-----	-----	-----	-----
Orange Blossom Trail	\$0.33	\$0.37	\$0.36	\$0.44	\$0.70	\$0.85	-----	-----	-----	-----
Interstate 4 (I-4)	\$0.28	\$0.32	\$0.29	\$0.35	\$0.47	\$0.57	-----	-----	\$0.96	\$1.32
Orange Avenue	\$0.24	\$0.28	\$0.24	\$0.29	\$0.35	\$0.43	-----	-----	\$0.47	\$0.65
Rosalind Avenue	-----	-----	-----	-----	-----	-----	-----	-----	-----	-----
Mills Avenue	-----	-----	-----	-----	-----	-----	-----	-----	-----	-----
Bumby Avenue	\$0.27	\$0.33	\$0.27	\$0.35	\$0.35	\$0.44	-----	-----	\$0.39	\$0.54
Crystal Lake Drive	-----	-----	-----	-----	-----	-----	-----	-----	-----	-----
Conway Road	\$0.26	\$0.30	\$0.26	\$0.32	\$0.31	\$0.38	-----	-----	\$0.34	\$0.43
Andes Avenue	\$0.27	\$0.31	\$0.27	\$0.32	\$0.32	\$0.38	-----	-----	\$0.34	\$0.42
Semorán Blvd (SR 436)	\$0.25	\$0.29	\$0.25	\$0.30	\$0.29	\$0.35	-----	-----	\$0.31	\$0.38
Yucatan Drive	-----	-----	-----	-----	-----	-----	-----	-----	-----	-----
Goldenrod Road	\$0.21	\$0.25	\$0.21	\$0.25	\$0.24	\$0.28	-----	-----	\$0.24	\$0.29
Chickasaw Trail	\$0.20	\$0.23	\$0.20	\$0.23	\$0.22	\$0.26	-----	-----	\$0.22	\$0.27
SR 417 (GreeneWay)	\$0.18	\$0.21	\$0.17	\$0.20	\$0.19	\$0.23	-----	-----	\$0.19	\$0.23
Dean Road	\$0.21	\$0.25	\$0.21	\$0.25	\$0.23	\$0.28	-----	-----	\$0.23	\$0.29
Rouse Road	\$0.21	\$0.25	\$0.21	\$0.25	\$0.23	\$0.27	-----	-----	\$0.23	\$0.28
Alafaya Trail	\$0.19	\$0.23	\$0.19	\$0.23	\$0.21	\$0.24	-----	-----	\$0.20	\$0.25
SR 50 (East Colonial Dr)	\$0.18	\$0.20	\$0.17	\$0.20	\$0.18	\$0.22	-----	-----	\$0.18	\$0.22



Toll Rates Between Interchanges (\$ Toll Rate/Mile) - 2 Axle Vehicles Only
SR 408 (East-West Expressway) - Continued

From	To									
	Interstate 4 (I-4)		Orange Avenue		Rosalind Avenue		Mills Avenue		Bumby Avenue	
	E-PASS	CASH	E-PASS	CASH	E-PASS	CASH	E-PASS	CASH	E-PASS	CASH
Florida's Turnpike	\$0.21	\$0.25	\$0.20	\$0.23	-----	-----	\$0.24	\$0.29	\$0.22	\$0.27
SR 50/Clarke Road	\$0.23	\$0.28	\$0.22	\$0.26	-----	-----	\$0.26	\$0.31	\$0.24	\$0.29
Good Homes Road	\$0.26	\$0.30	\$0.24	\$0.28	-----	-----	\$0.28	\$0.34	\$0.25	\$0.31
Hiwassee Road	\$0.29	\$0.35	\$0.26	\$0.32	-----	-----	\$0.31	\$0.39	\$0.28	\$0.35
Kirkman Road	\$0.24	\$0.28	\$0.21	\$0.25	-----	-----	\$0.28	\$0.31	\$0.24	\$0.27
Pine Hills Road	\$0.28	\$0.32	\$0.24	\$0.28	-----	-----	\$0.31	\$0.34	\$0.27	\$0.30
Old Winter Garden/Mercy-Ortman Dr	\$0.29	\$0.35	\$0.24	\$0.29	-----	-----	\$0.32	\$0.41	\$0.27	\$0.35
John Young Parkway	\$0.47	\$0.57	\$0.35	\$0.43	-----	-----	\$0.43	\$0.55	\$0.35	\$0.44
Tampa Avenue	-----	-----	-----	-----	-----	-----	-----	-----	-----	-----
Orange Blossom Trail	\$0.96	\$1.32	\$0.47	\$0.65	-----	-----	\$0.54	\$0.74	\$0.39	\$0.54
Interstate 4 (I-4)	-----	-----	\$0.00	\$0.00	-----	-----	\$0.38	\$0.52	\$0.25	\$0.34
Orange Avenue	-----	-----	-----	-----	-----	-----	-----	-----	-----	-----
Rosalind Avenue	-----	-----	-----	-----	-----	-----	\$0.94	\$1.29	\$0.41	\$0.56
Mills Avenue	-----	-----	-----	-----	-----	-----	-----	-----	\$0.72	\$0.99
Bumby Avenue	\$0.25	\$0.34	-----	-----	-----	\$0.56	-----	-----	-----	-----
Crystal Lake Drive	-----	-----	-----	-----	-----	-----	-----	-----	-----	-----
Conway Road	\$0.24	\$0.29	-----	-----	-----	\$0.39	\$0.41	\$0.50	-----	-----
Andes Avenue	\$0.26	\$0.30	-----	-----	-----	\$0.37	\$0.40	\$0.45	-----	-----
Semorran Blvd (SR 436)	\$0.23	\$0.26	-----	-----	-----	\$0.32	\$0.33	\$0.38	-----	-----
Yucatan Drive	-----	-----	-----	-----	-----	-----	-----	-----	-----	-----
Goldenrod Road	\$0.17	\$0.20	-----	-----	-----	\$0.23	\$0.23	\$0.26	-----	-----
Chickasaw Trail	\$0.16	\$0.18	-----	-----	-----	\$0.21	\$0.20	\$0.23	-----	-----
SR 417 (GreeneWay)	\$0.13	\$0.15	-----	-----	-----	\$0.17	\$0.16	\$0.18	-----	-----
Dean Road	\$0.18	\$0.22	-----	-----	-----	\$0.24	\$0.22	\$0.26	-----	-----
Rouse Road	\$0.19	\$0.22	-----	-----	-----	\$0.24	\$0.22	\$0.25	-----	-----
Alafaya Trail	\$0.17	\$0.20	-----	-----	-----	\$0.21	\$0.19	\$0.22	-----	-----
SR 50 (East Colonial Dr)	\$0.14	\$0.17	-----	-----	-----	\$0.18	\$0.16	\$0.19	-----	-----



Toll Rates Between Interchanges (\$ Toll Rate/Mile) - 2 Axle Vehicles Only
 SR 408 (East-West Expressway) - Continued

From	To											
	Crystal Lake Drive		Conway Road		Andes Avenue		Semoran Blvd.		Yucatan Drive		Goldenrod Road	
	E-PASS	CASH	E-PASS	CASH	E-PASS	CASH	E-PASS	CASH	E-PASS	CASH	E-PASS	CASH
Florida's Turnpike	-----	-----	\$0.22	\$0.26	\$0.23	\$0.26	-----	-----	-----	-----	\$0.20	\$0.23
SR 50/Clarke Road	-----	-----	\$0.24	\$0.28	\$0.24	\$0.28	-----	-----	-----	-----	\$0.21	\$0.24
Good Homes Road	-----	-----	\$0.25	\$0.30	\$0.26	\$0.30	-----	-----	-----	-----	\$0.22	\$0.26
Hiwassee Road	-----	-----	\$0.27	\$0.33	\$0.28	\$0.33	-----	-----	-----	-----	\$0.23	\$0.27
Kirkman Road	-----	-----	\$0.24	\$0.28	\$0.25	\$0.29	-----	-----	-----	-----	\$0.20	\$0.23
Pine Hills Road	-----	-----	\$0.26	\$0.30	\$0.27	\$0.31	-----	-----	-----	-----	\$0.21	\$0.25
Old Winter Garden/Mercy-Ortman Dr	-----	-----	\$0.26	\$0.32	\$0.27	\$0.32	-----	-----	-----	-----	\$0.21	\$0.25
John Young Parkway	-----	-----	\$0.31	\$0.38	\$0.32	\$0.38	-----	-----	-----	-----	\$0.24	\$0.28
Tampa Avenue	-----	-----	-----	-----	-----	-----	-----	-----	-----	-----	-----	-----
Orange Blossom Trail	-----	-----	\$0.34	\$0.43	\$0.34	\$0.42	-----	-----	-----	-----	\$0.24	\$0.29
Interstate 4 (I-4)	-----	-----	\$0.24	\$0.29	\$0.26	\$0.30	-----	-----	-----	-----	\$0.17	\$0.20
Orange Avenue	-----	-----	\$0.29	\$0.35	\$0.30	\$0.35	-----	-----	-----	-----	\$0.19	\$0.22
Rosalind Avenue	-----	-----	\$0.32	\$0.39	\$0.33	\$0.37	-----	-----	-----	-----	\$0.20	\$0.23
Mills Avenue	-----	-----	\$0.41	\$0.50	\$0.40	\$0.45	-----	-----	-----	-----	\$0.23	\$0.26
Bumby Avenue	-----	-----	-----	-----	-----	-----	-----	-----	-----	-----	-----	-----
Crystal Lake Drive	-----	-----	\$1.30	\$1.59	\$0.79	\$0.91	-----	-----	-----	-----	\$0.32	\$0.37
Conway Road	\$1.30	\$1.59	-----	-----	-----	-----	-----	-----	-----	-----	-----	-----
Andes Avenue	\$0.79	\$0.91	-----	-----	-----	-----	-----	-----	-----	-----	-----	-----
Semoran Blvd (SR 436)	\$0.57	\$0.66	-----	-----	-----	-----	-----	-----	-----	-----	-----	-----
Yucatan Drive	-----	-----	-----	-----	-----	-----	-----	-----	-----	-----	-----	-----
Goldenrod Road	\$0.32	\$0.37	-----	-----	-----	-----	-----	-----	-----	-----	\$0.66	\$0.81
Chickasaw Trail	\$0.27	\$0.31	-----	-----	-----	-----	-----	-----	-----	-----	-----	-----
SR 417 (GreeneWay)	\$0.20	\$0.23	-----	-----	-----	-----	-----	-----	-----	-----	\$0.00	\$0.00
Dean Road	\$0.26	\$0.32	-----	-----	-----	-----	-----	-----	-----	-----	\$0.20	\$0.27
Rouse Road	\$0.26	\$0.30	-----	-----	-----	-----	-----	-----	-----	-----	\$0.20	\$0.25
Alafaya Trail	\$0.22	\$0.26	-----	-----	-----	-----	-----	-----	-----	-----	\$0.16	\$0.19
SR 50 (East Colonial Dr)	\$0.18	\$0.22	-----	-----	-----	-----	-----	-----	-----	-----	\$0.12	\$0.14



Toll Rates Between Interchanges (\$ Toll Rate/Mile) - 2 Axle Vehicles Only
 SR 408 (East-West Expressway) - Continued

From	To											
	Chickasaw Trail		SR 417 (GreeneWay)		Dean Road		Rouse Road		Alafaya Trail		SR 50 (Colonial Dr.)	
	E-PASS	CASH	E-PASS	CASH	E-PASS	CASH	E-PASS	CASH	E-PASS	CASH	E-PASS	CASH
Florida's Turnpike	\$0.19	\$0.22	\$0.17	\$0.20	\$0.20	\$0.24	\$0.20	\$0.23	\$0.19	\$0.22	\$0.17	\$0.20
SR 50/Clarke Road	\$0.20	\$0.23	\$0.18	\$0.21	\$0.25	\$0.25	\$0.21	\$0.24	\$0.19	\$0.23	\$0.18	\$0.21
Good Homes Road	\$0.21	\$0.25	\$0.19	\$0.22	\$0.26	\$0.26	\$0.22	\$0.25	\$0.20	\$0.24	\$0.18	\$0.22
Hiwassee Road	\$0.22	\$0.26	\$0.20	\$0.22	\$0.27	\$0.27	\$0.22	\$0.27	\$0.21	\$0.25	\$0.19	\$0.23
Kirkman Road	\$0.19	\$0.22	\$0.17	\$0.20	\$0.24	\$0.24	\$0.20	\$0.24	\$0.19	\$0.22	\$0.17	\$0.20
Pine Hills Road	\$0.20	\$0.23	\$0.18	\$0.21	\$0.25	\$0.25	\$0.21	\$0.25	\$0.19	\$0.23	\$0.18	\$0.20
Old Winter Garden/Mercy-Ortman Dr	\$0.20	\$0.23	\$0.17	\$0.21	\$0.25	\$0.25	\$0.21	\$0.25	\$0.19	\$0.23	\$0.17	\$0.20
John Young Parkway	\$0.22	\$0.26	\$0.19	\$0.23	\$0.28	\$0.28	\$0.23	\$0.27	\$0.21	\$0.24	\$0.18	\$0.22
Tampa Avenue	-----	-----	-----	-----	-----	-----	-----	-----	-----	-----	-----	-----
Orange Blossom Trail	\$0.22	\$0.27	\$0.19	\$0.23	\$0.29	\$0.29	\$0.23	\$0.28	\$0.20	\$0.25	\$0.18	\$0.22
Interstate 4 (I-4)	\$0.16	\$0.18	\$0.13	\$0.18	\$0.22	\$0.22	\$0.19	\$0.22	\$0.17	\$0.20	\$0.14	\$0.17
Orange Avenue	-----	-----	-----	-----	-----	-----	-----	-----	-----	-----	-----	-----
Rosalind Avenue	\$0.18	\$0.21	\$0.15	\$0.20	\$0.24	\$0.24	\$0.20	\$0.24	\$0.18	\$0.21	\$0.15	\$0.18
Mills Avenue	\$0.20	\$0.23	\$0.16	\$0.22	\$0.26	\$0.26	\$0.22	\$0.25	\$0.19	\$0.22	\$0.16	\$0.19
Bumby Avenue	-----	-----	-----	-----	-----	-----	-----	-----	-----	-----	-----	-----
Crystal Lake Drive	\$0.27	\$0.31	\$0.20	\$0.26	\$0.32	\$0.32	\$0.26	\$0.30	\$0.22	\$0.26	\$0.18	\$0.22
Conway Road	-----	-----	-----	-----	-----	-----	-----	-----	-----	-----	-----	-----
Andes Avenue	-----	-----	-----	-----	-----	-----	-----	-----	-----	-----	-----	-----
Semorran Blvd (SR 436)	-----	-----	-----	-----	-----	-----	-----	-----	-----	-----	-----	-----
Yucatan Drive	\$0.45	\$0.55	\$0.26	\$0.34	\$0.43	\$0.43	\$0.31	\$0.38	\$0.25	\$0.31	\$0.20	\$0.24
Goldenrod Road	-----	-----	\$0.00	\$0.20	\$0.27	\$0.27	\$0.20	\$0.25	\$0.16	\$0.19	\$0.12	\$0.14
Chickasaw Trail	-----	-----	-----	-----	-----	-----	-----	-----	-----	-----	-----	-----
SR 417 (GreeneWay)	-----	-----	-----	\$0.67	\$0.91	\$0.91	\$0.39	\$0.48	\$0.25	\$0.30	\$0.16	\$0.20
Dean Road	-----	-----	-----	-----	-----	-----	-----	\$0.79	\$0.33	\$0.40	\$0.20	\$0.24
Rouse Road	-----	-----	\$0.39	\$0.64	\$0.79	\$0.79	-----	-----	\$0.46	\$0.62	\$0.19	\$0.26
Alafaya Trail	-----	-----	\$0.25	\$0.33	\$0.40	\$0.40	\$0.46	\$0.62	-----	-----	-----	-----
SR 50 (East Colonial Dr)	-----	-----	\$0.16	\$0.20	\$0.24	\$0.24	\$0.19	\$0.26	-----	-----	-----	-----

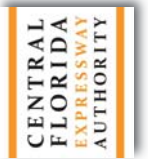

Toll Rates Between Interchanges (\$ Toll Rate/Mile) - 2 Axle Vehicles Only
 SR 408 (East-West Expressway) - Continued

From	To									
	Boggy Creek Rd.		Tradeport/Conway		Semoran Blvd/Airport		Goldenrod Road		Narcoossee Road	
	E-PASS	CASH	E-PASS	CASH	E-PASS	CASH	E-PASS	CASH	E-PASS	CASH
US 441/Florida Turnpike	\$0.22	\$0.28	\$0.17	\$0.21	\$0.13	\$0.16	\$0.11	\$0.13	\$0.09	\$0.11
Boggy Creek Road	-----	-----	\$1.01	\$1.16	\$0.42	\$0.49	\$0.28	\$0.32	\$0.21	\$0.24
Tradeport Dr / Conway Rd	\$1.01	\$1.16	-----	-----	\$0.73	\$0.83	\$0.38	\$0.44	\$0.26	\$0.30
Semoran Blvd / Airport	\$0.42	\$0.49	\$0.73	\$0.83	-----	-----	\$0.00	\$0.00	\$0.00	\$0.00
Goldenrod Road	\$0.28	\$0.32	\$0.38	\$0.44	\$0.00	\$0.00	-----	-----	\$0.00	\$0.00
Narcoossee Road	\$0.21	\$0.24	\$0.26	\$0.30	\$0.00	\$0.00	\$0.00	\$0.00	-----	-----
SR 417 (GreeneWay)	\$0.15	\$0.17	\$0.17	\$0.20	\$0.00	\$0.00	\$0.00	\$0.00	\$0.00	\$0.00
Monument Pkwy/ICP Blvd	\$0.17	\$0.19	\$0.19	\$0.21	\$0.10	\$0.11	\$0.11	\$0.13	\$0.14	\$0.16
Dallas Boulevard	\$0.16	\$0.18	\$0.17	\$0.19	\$0.11	\$0.12	\$0.12	\$0.13	\$0.13	\$0.15
SR 520	\$0.12	\$0.14	\$0.13	\$0.15	\$0.08	\$0.10	\$0.09	\$0.11	\$0.09	\$0.12
Brevard County Line	\$0.10	\$0.12	\$0.10	\$0.12	\$0.07	\$0.08	\$0.07	\$0.08	\$0.07	\$0.09

From	To									
	SR 417 (GreeneWay)		Monument Pkwy/ICP		Dallas Boulevard		SR 520		Brevard Cty Line	
	E-PASS	CASH	E-PASS	CASH	E-PASS	CASH	E-PASS	CASH	E-PASS	CASH
US 441/Florida Turnpike	\$0.07	\$0.09	\$0.11	\$0.13	\$0.11	\$0.13	\$0.09	\$0.11	\$0.08	\$0.10
Boggy Creek Road	\$0.15	\$0.17	\$0.17	\$0.19	\$0.16	\$0.18	\$0.12	\$0.14	\$0.10	\$0.12
Tradeport Dr / Conway Rd	\$0.17	\$0.20	\$0.19	\$0.21	\$0.17	\$0.19	\$0.13	\$0.15	\$0.10	\$0.12
Semoran Blvd / Airport	\$0.00	\$0.00	\$0.10	\$0.11	\$0.11	\$0.12	\$0.08	\$0.10	\$0.07	\$0.08
Goldenrod Road	\$0.00	\$0.00	\$0.11	\$0.13	\$0.12	\$0.13	\$0.09	\$0.11	\$0.07	\$0.08
Narcoossee Road	\$0.00	\$0.00	\$0.14	\$0.16	\$0.13	\$0.15	\$0.09	\$0.12	\$0.07	\$0.09
SR 417 (GreeneWay)	-----	-----	\$0.21	\$0.24	\$0.17	\$0.18	\$0.11	\$0.13	\$0.08	\$0.10
Monument Pkwy/ICP Blvd	\$0.21	\$0.24	-----	-----	\$0.27	\$0.31	-----	-----	-----	-----
Dallas Boulevard	\$0.17	\$0.18	\$0.27	\$0.31	-----	-----	-----	-----	-----	-----
SR 520	\$0.11	\$0.13	\$0.12	\$0.16	-----	-----	-----	-----	\$0.05	\$0.10
Brevard County Line	\$0.08	\$0.10	\$0.08	\$0.11	-----	-----	\$0.05	\$0.10	-----	-----



Toll Rates Between Interchanges (\$ Toll Rate/Mile) - 2 Axle Vehicles Only
SR 528 (Beachline Expressway)

From	To											
	International Drive		John Young Parkway		Orange Blossom Trail		Florida Turnpike		Landstar Boulevard			
	E-PASS	CASH	E-PASS	CASH	E-PASS	CASH	E-PASS	CASH	E-PASS	CASH		
International Drive	-----	-----	\$0.32	\$0.35	\$0.24	\$0.27	-----	-----	\$0.24	\$0.25		
John Young Parkway	\$0.32	\$0.35	-----	-----	\$0.60	\$0.73	-----	-----	\$0.36	\$0.40		
Orange Blossom Trail	\$0.24	\$0.27	\$0.60	\$0.73	-----	-----	\$0.57	\$0.78	\$0.45	\$0.53		
Florida Turnpike	-----	-----	-----	-----	-----	-----	-----	-----	\$0.36	\$0.36		
Landstar Boulevard	\$0.24	\$0.25	\$0.36	\$0.40	\$0.45	\$0.53	\$0.36	\$0.36	-----	-----		
South Access Rd (Intl Airport)	\$0.24	\$0.26	\$0.30	\$0.35	\$0.33	\$0.38	\$0.28	\$0.31	\$0.39	\$0.43		
Boggy Creek Road	\$0.24	\$0.26	\$0.30	\$0.35	\$0.33	\$0.38	\$0.28	\$0.31	\$0.39	\$0.43		
Lake Nona Boulevard	\$0.20	\$0.22	\$0.23	\$0.27	\$0.24	\$0.28	\$0.20	\$0.21	\$0.24	\$0.27		
Narcoossee Road	\$0.17	\$0.19	\$0.18	\$0.21	\$0.18	\$0.21	\$0.14	\$0.16	\$0.17	\$0.18		
Moss Park Road	\$0.16	\$0.17	\$0.16	\$0.19	\$0.16	\$0.19	\$0.12	\$0.14	\$0.14	\$0.16		
Dowden Road	\$0.15	\$0.16	\$0.15	\$0.18	\$0.15	\$0.17	\$0.11	\$0.13	\$0.13	\$0.14		
SR 528 (Beachline Expwy)	\$0.14	\$0.15	\$0.14	\$0.16	\$0.13	\$0.15	\$0.10	\$0.11	\$0.11	\$0.12		
Lee Vista Boulevard	\$0.15	\$0.17	\$0.15	\$0.18	\$0.15	\$0.18	\$0.12	\$0.15	\$0.14	\$0.16		
Curry Ford Road	\$0.15	\$0.16	\$0.15	\$0.17	\$0.15	\$0.17	\$0.12	\$0.14	\$0.13	\$0.15		
SR 408 (East-West Expwy)	\$0.13	\$0.15	\$0.13	\$0.15	\$0.13	\$0.15	\$0.11	\$0.12	\$0.11	\$0.13		
SR 50 (Colonial Drive)	\$0.14	\$0.17	\$0.15	\$0.17	\$0.14	\$0.17	\$0.12	\$0.15	\$0.13	\$0.16		
University Boulevard	\$0.14	\$0.16	\$0.14	\$0.17	\$0.14	\$0.17	\$0.12	\$0.14	\$0.13	\$0.15		
Alma Avenue	\$0.14	\$0.17	\$0.14	\$0.18	\$0.14	\$0.18	\$0.12	\$0.15	\$0.13	\$0.16		



Toll Rates Between Interchanges (\$ Toll Rate/Mile) - 2 Axle Vehicles Only
SR 417 (Central Florida GreeneWay)

From	To											
	South Access (Airport)		Boggy Creek Road		Lake Nona Boulevard		Narcoossee Road		Moss Park Road			
	E-PASS	CASH	E-PASS	CASH	E-PASS	CASH	E-PASS	CASH	E-PASS	CASH		
International Drive	\$0.25	\$0.28	\$0.24	\$0.26	\$0.20	\$0.22	\$0.17	\$0.19	\$0.16	\$0.17		
John Young Parkway	\$0.30	\$0.35	\$0.30	\$0.35	\$0.23	\$0.27	\$0.18	\$0.21	\$0.16	\$0.19		
Orange Blossom Trail	\$0.33	\$0.38	\$0.33	\$0.38	\$0.24	\$0.28	\$0.18	\$0.21	\$0.16	\$0.19		
Florida Turnpike	\$0.39	\$0.46	\$0.39	\$0.46	\$0.27	\$0.32	\$0.20	\$0.24	\$0.17	\$0.20		
Landstar Boulevard	\$0.39	\$0.43	\$0.39	\$0.43	\$0.24	\$0.27	\$0.17	\$0.18	\$0.14	\$0.16		
South Access Rd (Intl Airport)	-----	-----	-----	-----	\$0.52	\$0.60	\$0.23	\$0.27	\$0.18	\$0.20		
Boggy Creek Road	-----	-----	-----	-----	\$0.52	\$0.60	\$0.23	\$0.27	\$0.18	\$0.20		
Lake Nona Boulevard	\$0.52	\$0.60	\$0.52	\$0.60	-----	-----	-----	-----	\$0.20	\$0.25		
Narcoossee Road	\$0.23	\$0.27	\$0.23	\$0.27	\$0.32	\$0.39	-----	-----	\$0.56	\$0.68		
Moss Park Road	\$0.18	\$0.20	\$0.18	\$0.20	\$0.20	\$0.25	\$0.56	\$0.68	-----	-----		
Dowden Road	\$0.16	\$0.18	\$0.16	\$0.18	\$0.17	\$0.20	\$0.34	\$0.42	\$0.60	\$0.81		
SR 528 (Beachline Expwy)	\$0.13	\$0.14	\$0.13	\$0.14	\$0.12	\$0.15	\$0.20	\$0.25	\$0.22	\$0.29		
Lee Vista Boulevard	\$0.16	\$0.19	\$0.16	\$0.19	\$0.16	\$0.21	\$0.23	\$0.30	\$0.25	\$0.34		
Curry Ford Road	\$0.15	\$0.17	\$0.15	\$0.17	\$0.15	\$0.19	\$0.20	\$0.24	\$0.20	\$0.26		
SR 408 (East-West Expwy)	\$0.12	\$0.14	\$0.12	\$0.14	\$0.12	\$0.15	\$0.15	\$0.18	\$0.14	\$0.18		
SR 50 (Colonial Drive)	\$0.14	\$0.17	\$0.14	\$0.17	\$0.14	\$0.18	\$0.17	\$0.22	\$0.17	\$0.22		
University Boulevard	\$0.14	\$0.17	\$0.14	\$0.17	\$0.14	\$0.17	\$0.17	\$0.20	\$0.16	\$0.20		
Alma Avenue	\$0.14	\$0.18	\$0.14	\$0.18	\$0.14	\$0.18	\$0.16	\$0.21	\$0.16	\$0.22		



Toll Rates Between Interchanges (\$ Toll Rate/Mile) - 2 Axle Vehicles Only
SR 417 (Central Florida GreeneWay) - Continued

From	To									
	Dowden Road		SR 528 (Beachline)		Lee Vista Boulevard		Curry Ford Road			
	E-PASS	CASH	E-PASS	CASH	E-PASS	CASH	E-PASS	CASH	E-PASS	CASH
International Drive	\$0.15	\$0.16	\$0.14	\$0.15	\$0.15	\$0.17	\$0.15	\$0.17	\$0.15	\$0.16
John Young Parkway	\$0.15	\$0.18	\$0.14	\$0.16	\$0.15	\$0.18	\$0.15	\$0.18	\$0.15	\$0.17
Orange Blossom Trail	\$0.15	\$0.17	\$0.13	\$0.15	\$0.15	\$0.18	\$0.15	\$0.18	\$0.15	\$0.17
Florida Turnpike	\$0.11	\$0.13	\$0.10	\$0.11	\$0.12	\$0.15	\$0.12	\$0.15	\$0.12	\$0.14
Landstar Boulevard	\$0.13	\$0.14	\$0.11	\$0.12	\$0.14	\$0.16	\$0.14	\$0.16	\$0.13	\$0.15
South Access Rd (Int'l Airport)	\$0.16	\$0.18	\$0.13	\$0.14	\$0.16	\$0.19	\$0.16	\$0.19	\$0.15	\$0.17
Boggy Creek Road	\$0.16	\$0.18	\$0.13	\$0.14	\$0.16	\$0.19	\$0.16	\$0.19	\$0.15	\$0.17
Lake Nona Boulevard	\$0.17	\$0.20	\$0.12	\$0.15	\$0.16	\$0.21	\$0.16	\$0.21	\$0.15	\$0.19
Narcoossee Road	\$0.34	\$0.42	\$0.20	\$0.25	\$0.23	\$0.30	\$0.23	\$0.30	\$0.20	\$0.24
Moss Park Road	\$0.60	\$0.81	\$0.22	\$0.29	\$0.25	\$0.34	\$0.25	\$0.34	\$0.20	\$0.26
Dowden Road	-----	-----	\$0.34	\$0.46	\$0.31	\$0.42	\$0.31	\$0.42	\$0.23	\$0.30
SR 528 (Beachline Expwy)	\$0.34	\$0.46	-----	-----	\$0.29	\$0.39	\$0.29	\$0.39	\$0.20	\$0.24
Lee Vista Boulevard	\$0.31	\$0.42	\$0.29	\$0.39	-----	-----	-----	-----	\$0.36	\$0.43
Curry Ford Road	\$0.23	\$0.30	\$0.20	\$0.24	\$0.36	\$0.43	\$0.36	\$0.43	-----	-----
SR 408 (East-West Expwy)	\$0.16	\$0.20	\$0.12	\$0.14	\$0.16	\$0.20	\$0.16	\$0.20	\$0.20	\$0.27
SR 50 (Colonial Drive)	\$0.19	\$0.24	\$0.16	\$0.20	\$0.20	\$0.26	\$0.20	\$0.26	\$0.25	\$0.34
University Boulevard	\$0.17	\$0.22	\$0.15	\$0.18	\$0.18	\$0.22	\$0.18	\$0.22	\$0.20	\$0.26
Aloma Avenue	\$0.17	\$0.23	\$0.15	\$0.20	\$0.18	\$0.24	\$0.18	\$0.24	\$0.19	\$0.27



Toll Rates Between Interchanges (\$ Toll Rate/Mile) - 2 Axle Vehicles Only
SR 417 (Central Florida GreeneWay) - Continued

From	To									
	SR 408 (East West)		SR 50 (Colonial Dr.)		University Boulevard		Aloma Avenue			
	E-PASS	CASH	E-PASS	CASH	E-PASS	CASH	E-PASS	CASH		
International Drive	\$0.13	\$0.15	\$0.14	\$0.17	\$0.14	\$0.16	\$0.14	\$0.14	\$0.17	
John Young Parkway	\$0.13	\$0.15	\$0.15	\$0.17	\$0.14	\$0.17	\$0.14	\$0.14	\$0.18	
Orange Blossom Trail	\$0.13	\$0.15	\$0.14	\$0.17	\$0.14	\$0.17	\$0.14	\$0.14	\$0.18	
Florida Turnpike	\$0.11	\$0.12	\$0.12	\$0.15	\$0.12	\$0.14	\$0.12	\$0.12	\$0.15	
Landstar Boulevard	\$0.11	\$0.13	\$0.13	\$0.16	\$0.13	\$0.15	\$0.13	\$0.13	\$0.16	
South Access Rd (Int'l Airport)	\$0.12	\$0.14	\$0.14	\$0.17	\$0.14	\$0.17	\$0.14	\$0.14	\$0.18	
Boggy Creek Road	\$0.12	\$0.14	\$0.14	\$0.17	\$0.14	\$0.17	\$0.14	\$0.14	\$0.18	
Lake Nona Boulevard	\$0.12	\$0.15	\$0.14	\$0.18	\$0.14	\$0.17	\$0.14	\$0.14	\$0.18	
Narcoossee Road	\$0.15	\$0.18	\$0.17	\$0.22	\$0.17	\$0.20	\$0.16	\$0.16	\$0.21	
Moss Park Road	\$0.14	\$0.18	\$0.17	\$0.22	\$0.16	\$0.20	\$0.16	\$0.16	\$0.22	
Dowden Road	\$0.16	\$0.20	\$0.19	\$0.24	\$0.17	\$0.22	\$0.17	\$0.17	\$0.23	
SR 528 (Beachline Expwy)	\$0.12	\$0.14	\$0.16	\$0.20	\$0.15	\$0.18	\$0.15	\$0.15	\$0.20	
Lee Vista Boulevard	\$0.16	\$0.20	\$0.20	\$0.26	\$0.18	\$0.22	\$0.18	\$0.18	\$0.24	
Curry Ford Road	\$0.20	\$0.27	\$0.25	\$0.34	\$0.20	\$0.26	\$0.19	\$0.19	\$0.27	
SR 408 (East-West Expwy)	-----	-----	\$0.33	\$0.44	\$0.21	\$0.25	\$0.19	\$0.19	\$0.27	
SR 50 (Colonial Drive)	\$0.33	\$0.44	-----	-----	\$0.36	\$0.44	-----	\$0.27	\$0.38	
University Boulevard	\$0.21	\$0.25	\$0.36	\$0.44	-----	-----	\$0.49	\$0.49	\$0.77	
Aloma Avenue	\$0.19	\$0.27	\$0.27	\$0.38	\$0.49	\$0.77	-----	-----	-----	



Toll Rates Between Interchanges (\$ Toll Rate/Mile) - 2 Axle Vehicles Only
SR 417 (Central Florida GreeneWay) - Continued

From	To											
	Seidel Road		Schofield Road		New Independence Pkwy		CR 535		Florida Turnpike		SR 50 (Colonial Dr.)	
	E-PASS	CASH	E-PASS	CASH	E-PASS	CASH	E-PASS	CASH	E-PASS	CASH	E-PASS	CASH
Seidel Road	-----	-----	\$0.259	\$0.354	\$0.201	\$0.245	\$0.162	\$0.178	\$0.120	\$0.132	\$0.117	\$0.128
Schofield Road	\$0.259	\$0.354	-----	-----	\$0.419	\$0.510	\$0.216	\$0.237	\$0.148	\$0.162	\$0.142	\$0.156
New Independence Parkway	\$0.201	\$0.245	\$0.419	\$0.510	-----	-----	\$0.314	\$0.343	\$0.187	\$0.205	\$0.179	\$0.196
CR 535 (Old Winter Garden)	\$0.162	\$0.178	\$0.216	\$0.237	\$0.314	\$0.343	-----	-----	\$0.186	\$0.254	\$0.167	\$0.228
Florida Turnpike (SR 91)	\$0.120	\$0.132	\$0.148	\$0.162	\$0.187	\$0.205	\$0.186	\$0.254	-----	-----	-----	-----
SR 50 (West Colonial Drive)	\$0.117	\$0.128	\$0.142	\$0.156	\$0.179	\$0.196	\$0.167	\$0.228	-----	-----	-----	-----
Plant St/Franklin St/SR 438	\$0.125	\$0.152	\$0.149	\$0.181	\$0.181	\$0.220	\$0.176	\$0.265	\$0.159	\$0.283	\$0.195	\$0.348
West Road	\$0.140	\$0.159	\$0.161	\$0.184	\$0.189	\$0.215	\$0.189	\$0.242	\$0.192	\$0.234	\$0.208	\$0.253
CR 437A (Ocoee Apopka Rd)	\$0.151	\$0.165	\$0.170	\$0.187	\$0.194	\$0.212	\$0.197	\$0.231	\$0.202	\$0.221	\$0.212	\$0.232
SR 414 (Apopka Expressway)	\$0.140	\$0.153	\$0.157	\$0.172	\$0.177	\$0.194	\$0.173	\$0.203	\$0.168	\$0.184	\$0.175	\$0.192
SR 429 Connector Road	\$0.119	\$0.131	\$0.131	\$0.144	\$0.145	\$0.159	\$0.132	\$0.155	\$0.118	\$0.130	\$0.122	\$0.133
Kelly Park Road	\$0.131	\$0.141	\$0.142	\$0.152	\$0.154	\$0.165	\$0.146	\$0.164	\$0.139	\$0.147	\$0.142	\$0.150

From	To											
	Plant/Franklin St.		West Road		CR 437A		SR 414 (Apopka Expwy)		SR 429 Connector Rd.		Kelly Park Road	
	E-PASS	CASH	E-PASS	CASH	E-PASS	CASH	E-PASS	CASH	E-PASS	CASH	E-PASS	CASH
Seidel Road	\$0.149	\$0.181	\$0.161	\$0.184	\$0.170	\$0.187	\$0.157	\$0.172	\$0.131	\$0.144	\$0.142	\$0.152
Schofield Road	\$0.181	\$0.220	\$0.189	\$0.215	\$0.194	\$0.212	\$0.177	\$0.194	\$0.145	\$0.159	\$0.154	\$0.165
New Independence Parkway	\$0.349	\$0.424	\$0.303	\$0.346	\$0.281	\$0.308	\$0.247	\$0.270	\$0.189	\$0.206	\$0.190	\$0.204
CR 535 (Old Winter Garden)	\$0.470	\$0.708	\$0.320	\$0.409	\$0.283	\$0.331	\$0.236	\$0.276	\$0.166	\$0.194	\$0.174	\$0.195
Florida Turnpike (SR 91)	\$0.195	\$0.348	\$0.208	\$0.253	\$0.212	\$0.232	\$0.175	\$0.192	\$0.122	\$0.133	\$0.142	\$0.150
SR 50 (West Colonial Drive)	\$0.195	\$0.348	\$0.326	\$0.398	\$0.273	\$0.298	\$0.215	\$0.235	\$0.140	\$0.153	\$0.156	\$0.166
Plant St/Franklin St/SR 438	-----	-----	\$0.326	\$0.398	\$0.545	\$0.597	\$0.354	\$0.387	\$0.188	\$0.206	\$0.191	\$0.202
West Road	\$0.163	\$0.199	-----	-----	\$0.545	\$0.597	\$1.008	\$1.104	\$0.286	\$0.314	\$0.245	\$0.260
CR 437A (Ocoee Apopka Rd)	\$0.215	\$0.235	\$0.354	\$0.387	-----	-----	\$0.405	\$0.552	\$0.161	\$0.219	\$0.180	\$0.207
SR 414 (Apopka Expressway)	\$0.140	\$0.153	\$0.188	\$0.206	\$0.115	\$0.157	-----	-----	\$0.000	\$0.000	\$0.197	\$0.197
SR 429 Connector Road	\$0.099	\$0.108	\$0.121	\$0.132	\$0.062	\$0.085	\$0.000	\$0.000	-----	-----	\$0.197	\$0.197
Kelly Park Road	\$0.156	\$0.208	\$0.191	\$0.254	\$0.153	\$0.242	\$0.107	\$0.186	\$0.197	\$0.342	-----	-----

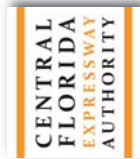

Toll Rates Between Interchanges (\$ Toll Rate/Mile) - 2 Axle Vehicles Only
SR 429 (Western Beltway and Wekiva Parkway)

From	To													
	SR 429 Connector Rd.		SR 451		Keene Road		Hiwassee Road		OBT - US 441 (East)		Bear Lake/Rose Ave.			
	E-PASS	CASH	E-PASS	CASH	E-PASS	CASH	E-PASS	CASH	E-PASS	CASH	E-PASS	CASH		
SR 429 Connector Road	-----	-----	-----	-----	-----	-----	-----	-----	-----	-----	-----	-----	-----	-----
SR 451 (Western Beltway)	-----	-----	-----	-----	-----	-----	-----	-----	-----	-----	-----	-----	-----	-----
Keene Road	-----	-----	-----	-----	-----	-----	-----	-----	-----	-----	-----	-----	-----	-----
Hiwassee Road (CR 435)	\$0.138	\$0.158	\$0.294	\$0.337	\$0.426	\$0.581	-----	-----	-----	-----	-----	-----	-----	-----
OBT - US 441 (East)	\$0.116	\$0.133	\$0.211	\$0.242	\$0.201	\$0.273	\$0.193	\$0.344	-----	-----	-----	-----	-----	-----
Bear Lake Rd / Rose Avenue	\$0.108	\$0.124	\$0.186	\$0.214	\$0.160	\$0.218	\$0.131	\$0.233	\$0.000	\$0.000	\$0.000	\$0.000	\$0.000	-----



Toll Rates Between Interchanges (\$ Toll Rate/Mile) - 2 Axle Vehicles Only
SR 414 (Apopka Expressway)

