



CFX Traffic Data and Statistics Manual 2022



TABLE OF CONTENTS

Executive Summary	i
--------------------------------	---

SECTION I - SYSTEM MAPS

Central Florida Expressway System	1
Toll Facility Location Map	2

SECTION II - TRAFFIC COUNTS

Traffic Counts Introduction	4
2021 AAWT Segment & Mainline Facility Volumes	5
SR 408 (East-West Expressway) Mainline Volume Summary	7
SR 408 (East-West Expressway) Interchange - Ramp Volume Summary	9
SR 528 (Beachline Expressway) Mainline Volume Summary	15
SR 528 (Beachline Expressway) Interchange - Ramp Volume Summary	16
SR 417 (Central Florida GreeneWay) Mainline Volume Summary	20
SR 417 (Central Florida GreeneWay) Interchange - Ramp Volume Summary	22
SR 429 (Western Beltway and Wekiva Parkway) Mainline Volume Summary	28
SR 429 (Western Beltway and Wekiva Parkway) Interchange - Ramp Volume Summary ..	29
SR 414 (Apopka Expressway) Mainline Volume Summary	33
SR 414 (Apopka Expressway) Interchange - Ramp Volume Summary	34
SR 451 (Western Beltway Connector Road) Mainline Volume Summary	37
SR 451 (Western Beltway Connector Road) Interchange - Ramp Volume Summary	38
SR 453 Mainline Volume Summary	40
SR 453 Interchange - Ramp Volume Summary	41

SR 538 (Poinciana Parkway) Mainline Volume Summary	43
SR 538 (Poinciana Parkway) Interchange - Ramp Volume Summary	44
Weekday, Daily and Monthly Adjustment Factors	46

SECTION III – MAINLINE TOLL FACILITY CHARACTERISTICS

Mainline Toll Facility Characteristics Introduction	51
SR 408 (East-West Expressway) Mainline Toll Facilities	52
Hiwassee Mainline Toll Facility - SR 408	53
Pine Hills Mainline Toll Facility - SR 408	55
Conway East & West Mainline Toll Facility - SR 408	57
Dean Mainline Toll Facility - SR 408	60
SR 528 (Beachline Expressway) Mainline Toll Facilities	62
Beachline Mainline Toll Facility - SR 528	63
Dallas Mainline Toll Facility - SR 528	65
SR 417 (Central Florida GreeneWay) Mainline Toll Facilities	67
John Young Mainline Toll Facility - SR 417	68
Boggy Creek Mainline Toll Facility - SR 417	70
Curry Ford Mainline Toll Facility - SR 417	72
University Mainline Toll Facility - SR 417	74
SR 429 (Western Beltway and Wekiva Parkway) Mainline Toll Facilities	76
Independence Mainline Toll Facility - SR 429	77
Forest Lake Mainline Toll Facility - SR 429	79
Ponkan Mainline Toll Gantry - SR 429	81
Mt. Plymouth Mainline Toll Gantry - SR 429	83
SR 414 (Apopka Expressway) Mainline Toll Facility	85
Coral Hills Mainline Toll Facility - SR 414	86

SR 453 Mainline Toll Gantry	88
Coronado Mainline Toll Gantry Facility - SR 453	89
SR 538 (Poinciana Parkway) Mainline Toll Gantry Facilities	91
Marigold Mainline Toll Gantry Facility	92
Koa Mainline Toll Gantry Facility	94
Goldenrod Mainline Toll Facility	96
Goldenrod Mainline Toll Facility - SR 551	97

SECTION IV - INTERCHANGES

SR 408 (East-West Expressway) Interchanges	100
SR 408 (East-West Expressway) Exit Numbers Exhibit	101
Exit 1 - SR 50/Clarke Road Spur	102
Exit 2 - Good Homes Road	103
Exit 4 - Hiawassee Road	104
Exit 5 - Kirkman Road	105
Exit 6 - Pine Hills Road	106
Exit 7 - Old Winter Garden Road/Ortman Drive	107
Exit 8A - John Young Parkway	108
Exit 8B - Tampa Avenue	109
Exit 9 - Orange Blossom Trail (US 441)	110
Exit 10A - Interstate 4	111
Exit 10B - Orange Avenue (1)	112
Exit 10B - Orange Avenue (2)	113
Exit 11A - Rosalind Avenue	114
Exit 11B - Mills Avenue	115
Exit 12A - Bumby Avenue	116
Exit 12B - Crystal Lake Drive	117
Exit 13 - Conway Road	118

Exit 14 - Andes Avenue/Semoran Boulevard (SR 436)	119
Exit 14 - Semoran Boulevard (SR 436)	120
Exit 14 - Yucatan Drive EB Entrance	121
Exit 16 - Goldenrod Road (SR 551)	122
Exit 17 - Chickasaw Trail	123
Exit 18 - Central Florida GreeneWay (SR 417)	124
Exit 19 - Dean Road	125
Exit 20 - Rouse Road	126
Exit 21 - Alafaya Trail	127
Exit 23 - East Colonial Drive (SR 50)	128
SR 528 (Beachline Expressway) Interchanges	129
SR 528 (Beachline Expressway) Exit Numbers Exhibit	130
Exit 8 - Boggy Creek Road	131
Exit 8 - Boggy Creek Road Rebate Gantries	132
Exit 9 - Tradeport Drive/Conway Road	133
Exits 11A & 11B - Semoran Boulevard (SR 436)	134
Exit 12 - Goldenrod Road (SR 551)	135
Exit 13 - Narcoossee Road (CR 15)	136
Exit 16 - Central Florida GreeneWay (SR 417)	137
Exit 19 - Innovation Way	138
Exit 24 - Dallas Boulevard	139
Exit 31 - SR 520	140
SR 417 (Central Florida GreeneWay) Interchanges	141
SR 417 (Central Florida GreeneWay) Exit Numbers Exhibits	142
Exit 6 - International Drive	144
Exit 10 - John Young Parkway	145
Exit 11 - US 17-92/US 441/Orange Blossom Trail	146
Exit 12 - Florida's Turnpike	147

Exit 14 - Landstar Boulevard	148
Exit 17A & B (1) - Boggy Creek Road/South Access Road/International Airport	149
Exit 17A & B (2) - Boggy Creek Road/South Access Road/International Airport	150
Exit 19 - Lake Nona Boulevard	151
Exit 22 - Narcoossee Road (CR 15)	152
Exit 23 - Moss Park Road	153
Exit 24 - Dowden Road	154
Exit 26 - Beachline Expressway (SR 528)	155
Exit 27 - Lee Vista Boulevard	156
Exit 30 - Curry Ford Road	157
Exit 33A & B - East-West Expressway (SR 408)	158
Exit 34 - East Colonial Drive (SR 50)	159
Exit 37A & B - University Boulevard	160
Exit 37A - NB SR 417 Exit to University Boulevard	161
SR 429 (Western Beltway and Wekiva Parkway) Interchanges	162
SR 429 (Western Beltway and Wekiva Parkway) Exit Numbers Exhibit	163
Exit 13 - Schofield Road	164
Exit 15 - New Independence Parkway	165
Exit 18 - Stoneybrook West	166
Exit 19 - CR 535 (Winter Garden Vineland Road)	167
Exit 22/23 - Florida's Turnpike/West Colonial Drive (SR 50)	168
Exit 24 - Plant Street/Franklin Street (SR 438)	169
Exit 24 - Plant Street/Franklin Street (SR 438)	170
Exit 26 - West Road/Clarcona-Ocoee Road	171
Exit 29 - Ocoee-Apopka Road (CR 437A)	172
Exit 30 - Apopka Expressway (SR 414)	173
Exit 34 - SR 429/SR 414 at US 441/Connector Road/CR 437	174
Exit 38 - Kelly Park Road	175
Exit 39 - SR 453	176

SR 414 (Apopka Expressway) Interchanges	177
SR 414 (Apopka Expressway) Exit Numbers Exhibit	178
Exit 4A - SR 451 (Western Beltway Connector Road)	179
Exit 4B - Western Beltway (SR 429)	180
Exit 5 - Marden Road	181
Exit 6 - Keene Road	182
Exit 8 - Hiawassee Road	183
Exit 9 - Orange Blossom Trail (US 441)	184
SR 451 (Western Beltway Connector Road) Interchanges	185
SR 451 (Western Beltway Connector Road) Exit Numbers Exhibit	186
Exit 4A/4B - SR 414 East/SR 429 South	187
Exit 33 - Orange Blossom Trail (US 441)	188
SR 453 Interchanges	189
SR 453 Exit Numbers Exhibit	190
Exit 39 - SR 429 (Western Beltway and Wekiva Parkway)	191
Exit 3 - SR 453 at SR 46	192
SR 538 (Poinciana Parkway) Interchanges	193
SR 528 (Poinciana Parkway) Exit Numbers Exhibit	194
Marigold Avenue	195
Koa Street	196
Exit To and From Cypress Parkway	197

SECTION V - GENERAL STATISTICS

General Statistics Introduction	199
Expressway Mileage, Lane Miles, Toll Facility Lanes and Toll Rate Schedules	200
Expressway Mileage and Total Lane Miles	201
Toll Facilities Lane Summary	202
Toll Rate Schedule	205

Distance Between Interchanges	208
SR 408 (East-West Expressway)	209
SR 528 (Beachline Expressway)	218
SR 417 (Central Florida GreeneWay)	220
SR 429 (Western Beltway)	226
SR 414 (Apopka Expressway)	229
SR 451 (Western Beltway Connector Road)	230
SR 453	231
SR 538 (Poinciana Parkway)	232
Toll Rates Between Interchanges	233
SR 408 (East-West Expressway)	234
SR 528 (Beachline Expressway)	243
SR 417 (Central Florida GreeneWay)	245
SR 429 (Western Beltway)	251
SR 414 (Apopka Expressway)	256
SR 453	257
SR 538 (Poinciana Parkway)	258
Cost per Mile Between Interchanges	259
SR 408 (East-West Expressway)	260
SR 528 (Beachline Expressway)	269
SR 417 (Central Florida GreeneWay)	271
SR 429 (Western Beltway)	277
SR 414 (Apopka Expressway)	282
SR 453	283
SR 538 (Poinciana Parkway)	284

Executive Summary

At the end of 2022, the Central Florida Expressway Authority (CFX) system includes 125 centerline miles, 870 lane miles (including ramps), 73 interchanges, 364 bridges and 19 mainline toll facilities. CFX's system includes SR 408 (Spessard L. Holland Expressway and Arnold Palmer Expressway), SR 528 (Martin Andersen Beachline Expressway), SR 417 (Central Florida GreeneWay), SR 429 (Daniel Webster Western Beltway and Wekiva Parkway), SR 414 (John Land Apopka Expressway), SR 451, SR 453 and SR 538 (Poinciana Parkway).

“To provide the region with a world-class, integrated mobility network that drives economic prosperity and quality of life”

Vision Statement

On average, over 1.5 million toll transactions are recorded every day. CFX is authorized to build, operate and maintain a transportation facility in Central Florida, incorporating Brevard, Lake, Orange, Osceola and Seminole counties. This five-county region has more than 3 million residents and over 75 million visitors annually.

Towards the goal of a world-class system and the strategic priority to build a customer-driven organization, CFX prepares this manual to provide a complete set of data including traffic volumes, traffic characteristics, toll facility operations and interchange lane configurations for their system. This data is utilized to project traffic trends and identify future capacity improvement projects within the system that can then be included into the Five-Year Work Plan.

Traffic volumes have steadily increased in 2021 and 2022 since the COVID-19 pandemic greatly reduced traffic volumes in 2020 where businesses and schools moved to virtual work. Businesses and schools continue to transition back to in-person work as the COVID-19 pandemic has subsided. Across the four most traveled expressways on the CFX system traffic has increased by 13.9% from 2020 to 2021 and 8.7% from 2021 to 2022. This growth has led to total traffic on the CFX system surpassing pre-Covid traffic volumes.

The data collected and detailed in this report is a snapshot in time. It should be noted that this data varies with time due to a number of influences. Factors such as construction and weather can affect the routes that drivers choose to travel. Some of the activities controlled by CFX and others that may influence traffic data include:

- Existing System Capacity Improvements (under construction)
 - Widening SR 417 from International Drive to John Young Parkway (417-141)
 - Widening SR 417 from John Young Parkway to Landstar Boulevard (417-142)
 - Widening SR 417 from Landstar Boulevard to Boggy Creek Road (417-149)
 - Widening SR 417 from Narcoossee Road to SR 528 (417-150)
 - Widening SR 417 from Boggy Creek Road to Narcoossee Road (417-151)
 - Widening SR 429 from CR 535 to Florida's Turnpike (429-154)
 - Widening SR 429 from Florida's Turnpike to West Road (429-152)
 - Widening SR 429 from West Road to SR 414 (429-153)
 - Widening SR 538 from Ronald Reagan Parkway to Cypress Parkway (538-165)

- New and/or Modified Interchanges (complete and/or under construction)
 - SR 408 / Interstate 4 Ultimate Interchange (In partnership with others)
 - SR 417 / Florida's Turnpike Interchange Improvements (By others)
 - SR 528 / SR 436 Interchange Improvements

SECTION I: System Maps

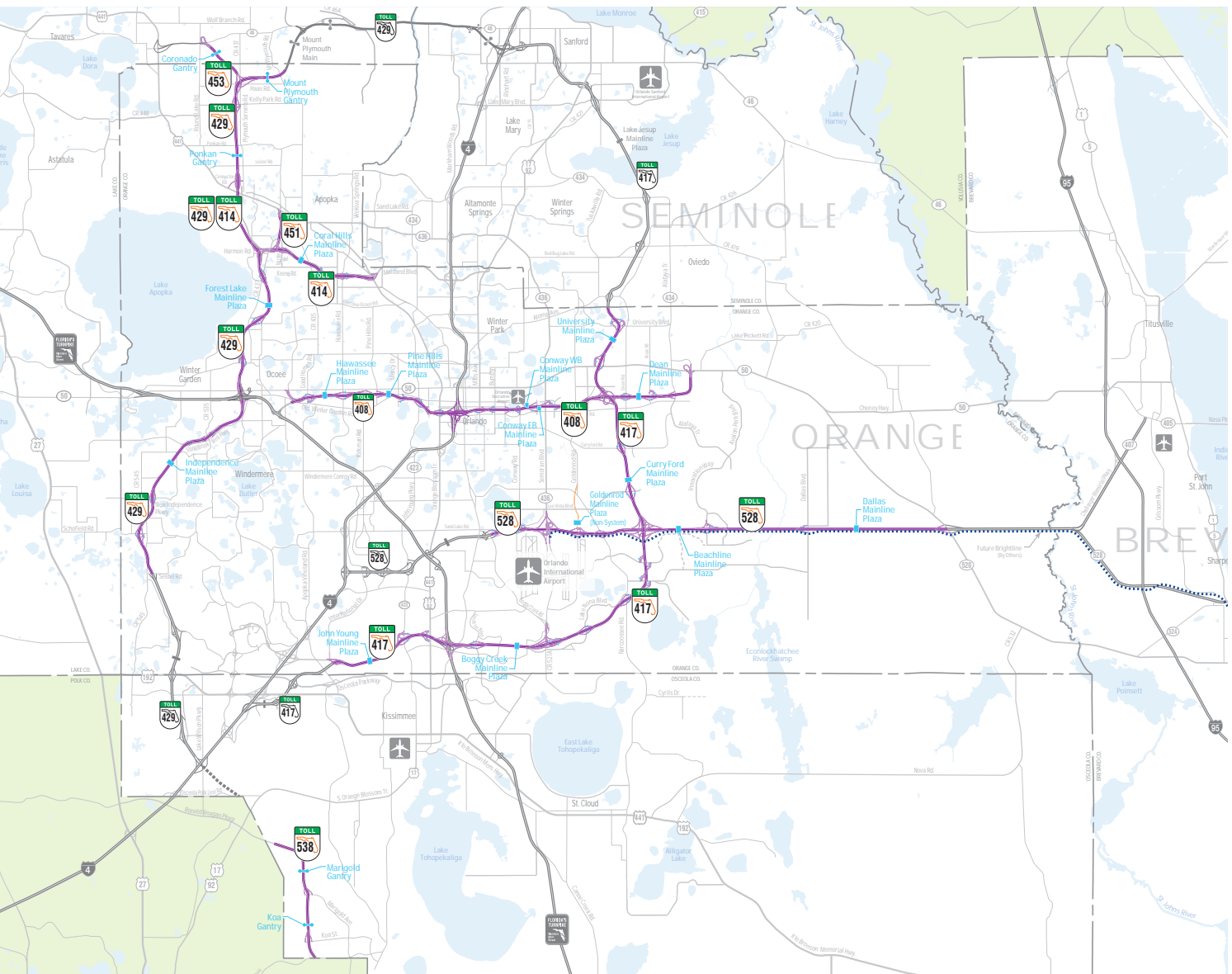

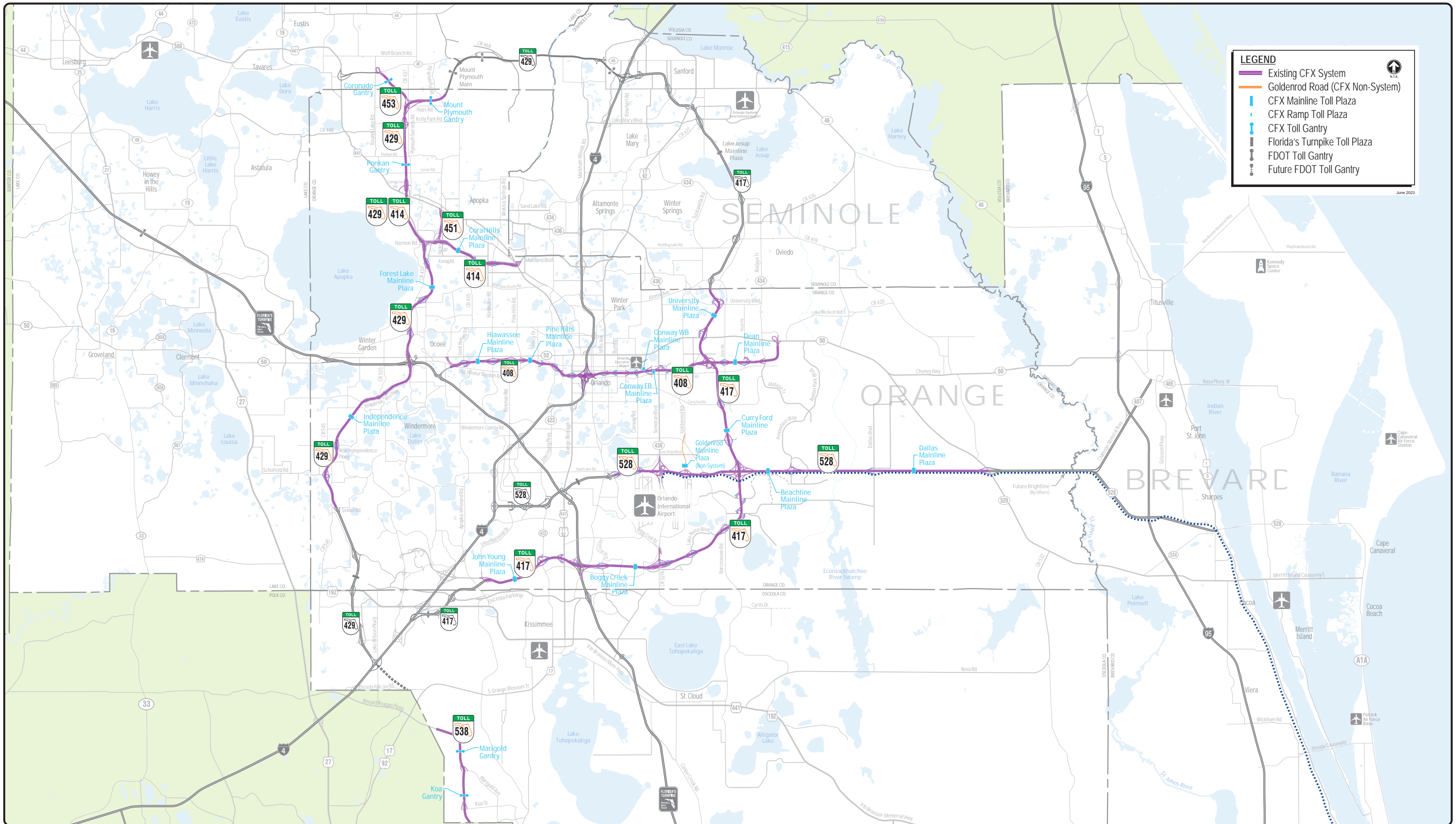

LEGEND

- Existing CFX System
- Goldenrod Road (CFX Non-System)
- CFX Mainline Toll Plaza
- CFX Ramp Toll Plaza
- CFX Toll Gantry
- Florida's Turnpike Toll Plaza
- FDOT Toll Gantry
- Future FDOT Toll Gantry

June 2023

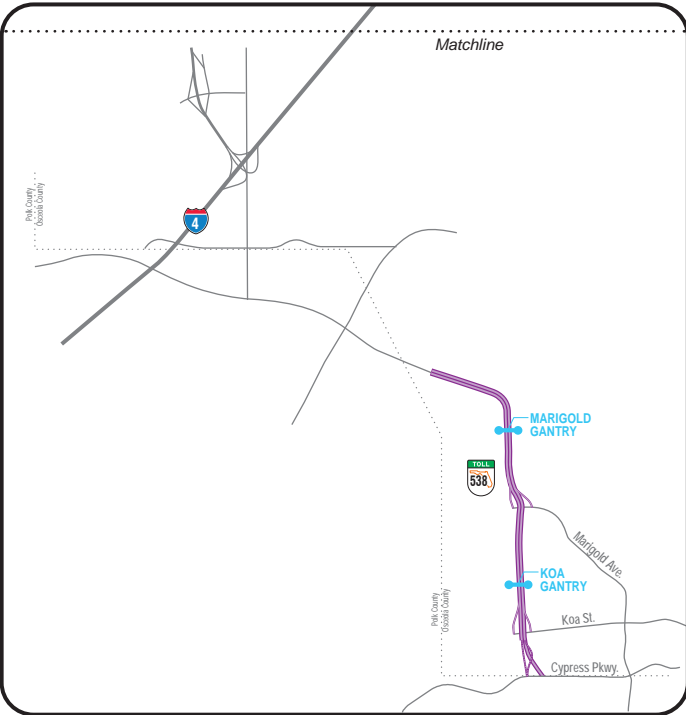
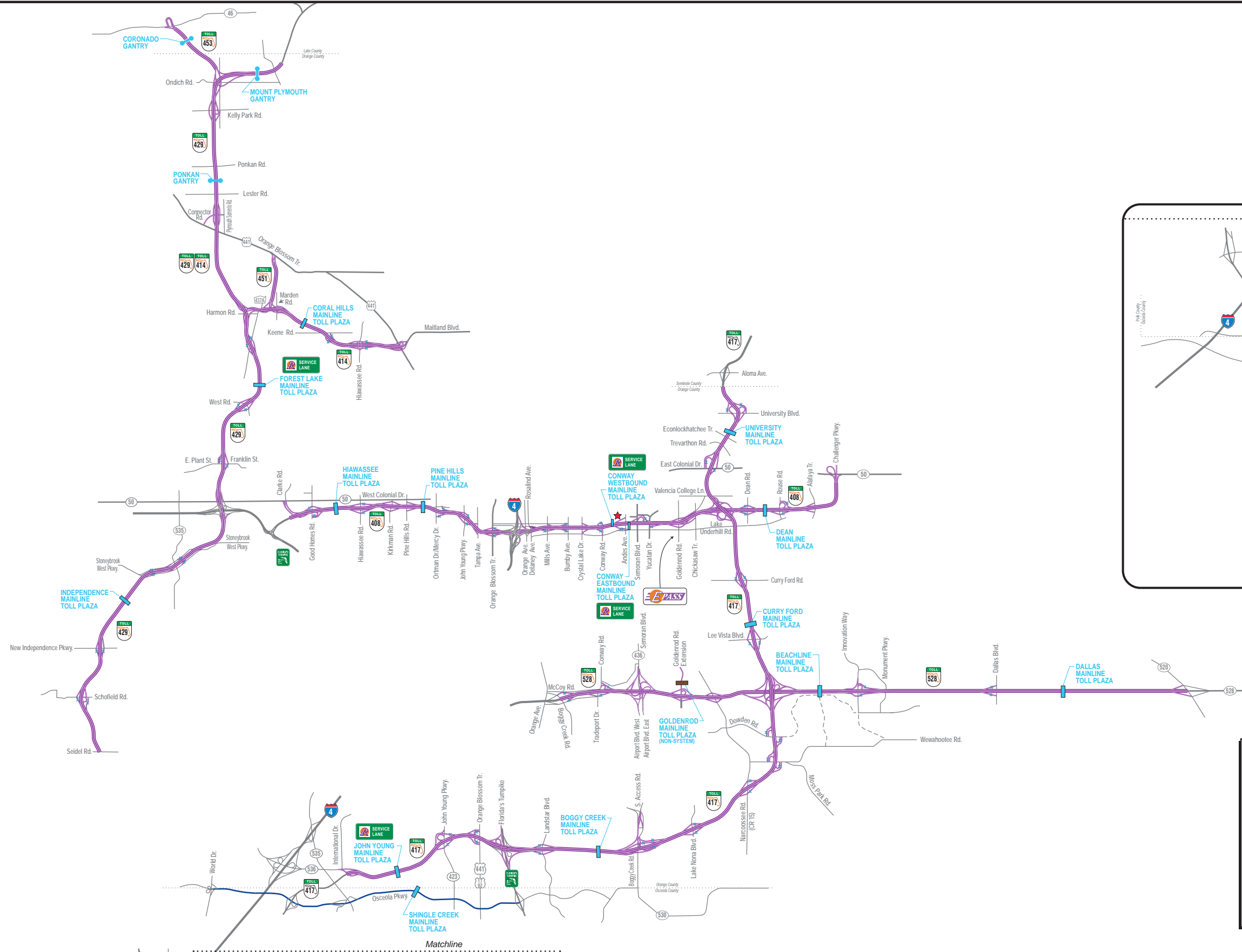

LEGEND

- Existing CFX System
- Main Toll Plaza
- Goldenrod Toll Facility (non-system)
- AET Toll Gantry
- CFX Ramp Toll Plaza
- E-PASS Service Center
- Reload E-PASS Service Lane
- CFX Headquarters
- Osceola Parkway



TOLL FACILITY LOCATION MAP
CFX Expressway System

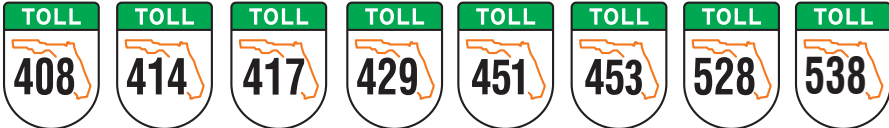

SECTION II: Traffic Counts



Traffic Counts

Traffic data presented in this manual was collected in April 2022 at CFX System ramps and mainline locations. Collection occurred on Monday thru Friday for the entire month of April 2022 utilizing the Wavetronics Data Collection Sensors (SS125 HD) recently installed throughout the CFX system. Pneumatic Tube counts were collected for areas on the system not covered by the Wavetronics sensors. Traffic data collected at the ramp and mainline toll plazas was also utilized to calculate the Annual Average Weekday Traffic (AAWT).

Monthly adjustment factors used to convert 24-hour weekday traffic counts to AAWT, are presented for each mainline segment and their accompanying ramps. These factors are based on the sensor information for mainline toll plazas. For example, if a 24-hour roadway count is collected on a normal weekday in April at a certain location, then that count would be multiplied by the appropriate monthly (April) factor to convert it to an annual average weekday volume. This normalizes the variations in weekly and monthly traffic, allowing counts taken at different times of the year can be compared.

Traffic volumes have steadily increased in 2021 and 2022 since the COVID-19 pandemic greatly reduced traffic volumes in 2020 where businesses and schools moved to virtual work. As a result of the traffic growth since the 2020 Covid-19 pandemic, traffic volumes have surpassed pre-pandemic traffic.

The following pages contain estimates of AAWT for all mainline sections and ramps associated with the CFX system facilities. The data includes the most recent observations, as well as historical traffic volumes starting from the year 2012 (where applicable).

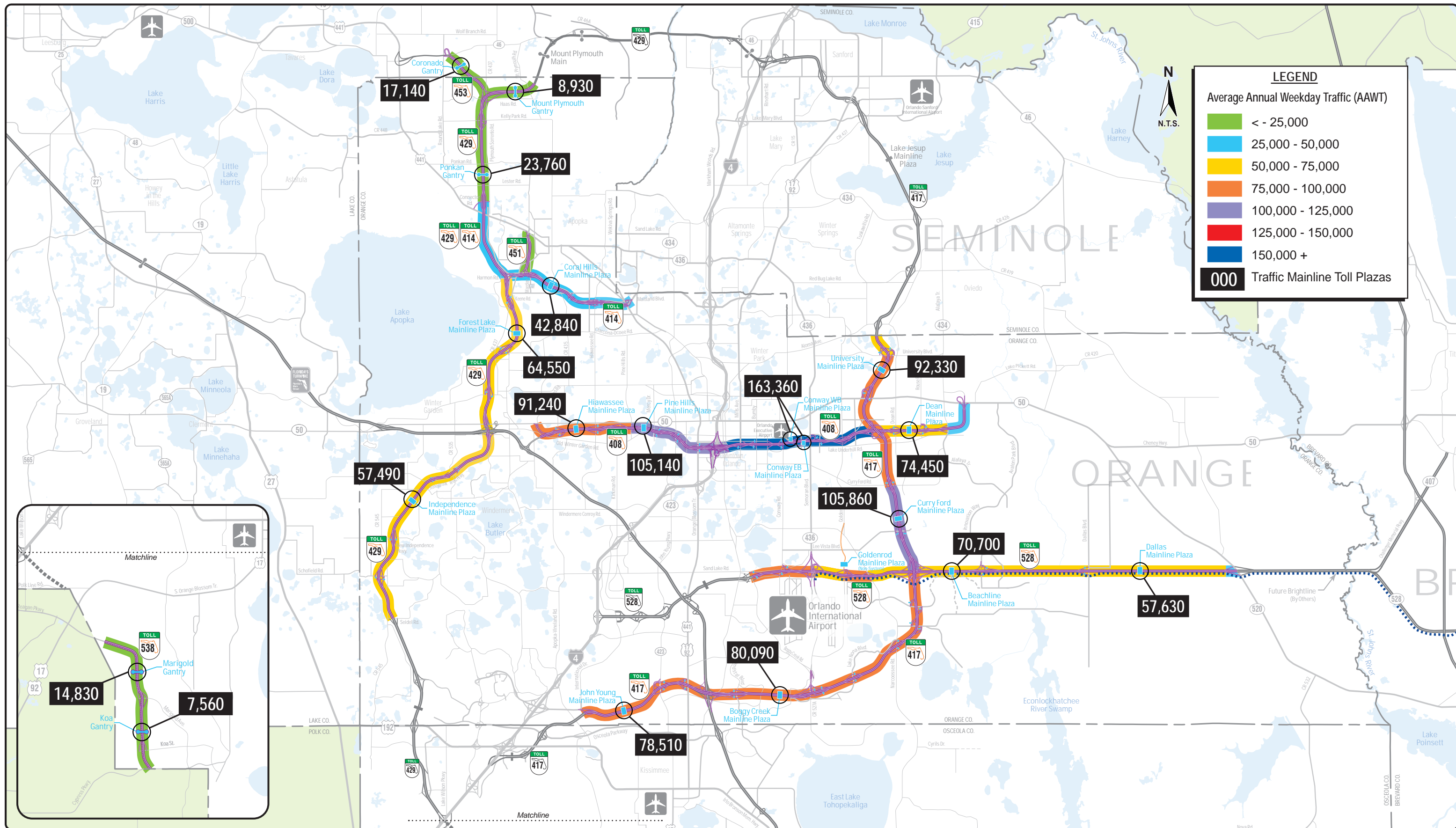

East-West Expressway



Existing and Historical Annual Average Weekday Mainline Traffic Volumes

Location	Year 2012	Year 2013	Year 2014	Year 2015	Year 2016	Year 2017	Year 2018	Year 2019	Year 2020	Year 2021	Year 2022
Florida's Turnpike to SR 50 / Spur Clarke Road	44,130	46,360	50,710	57,450	62,830	67,590	72,600	74,590	60,790	69,890	79,770
SR 50 Spur / Clarke Road to Good Homes Road	53,930	56,070	60,500	68,170	73,650	77,240	82,930	86,120	69,640	79,610	91,420
Good Homes Road to Hiwassee Road	56,330	57,750	61,440	69,490	73,510	76,370	81,940	86,170	69,530	79,090	91,240
Hiwassee Road to Kirkman Road	60,960	62,410	66,730	73,490	76,680	80,610	85,590	90,260	73,510	83,970	96,450
Kirkman Road to Pine Hills Road	65,970	66,710	71,580	78,780	81,440	83,990	89,390	92,170	73,100	84,930	95,400
Pine Hills Road to Old Winter Garden Road	71,190	72,020	77,210	85,210	89,080	91,620	96,220	99,470	80,290	92,470	105,140
Old Winter Garden Road to John Young Parkway	74,850	76,310	81,130	90,450	94,740	97,680	102,690	105,640	85,870	99,090	111,810
John Young Parkway to Tampa Avenue	77,060	78,730	83,890	93,600	97,370	100,260	108,760	107,710	87,980	101,450	114,400
Tampa Avenue to US 441 (Orange Blossom Trail)	75,200	76,940	81,830	91,110	93,780	97,170	103,410	100,830	84,560	98,530	109,970
US 441 (Orange Blossom Trail) to Interstate 4 (I-4)	76,990	79,710	84,860	93,810	96,210	101,210	101,140	100,460	87,400	100,750	112,290
Interstate 4 (I-4) to Rosalind Avenue	113,060	114,050	118,820	127,860	135,130	134,490	139,250	144,300	122,700	140,870	155,370
Rosalind Avenue to Mills Avenue	131,970	132,930	139,470	152,210	157,830	155,540	159,690	159,210	137,930	156,380	172,840
Mills Avenue to Bumby Avenue	140,210	141,140	147,810	160,220	166,820	163,710	170,000	169,560	144,240	163,160	181,480

Notes:

1. SR 408 under construction in Years 2015-2020 at the Interstate 4 (I-4) Interchange (I-4 Ultimate). Orange Avenue WB On-ramp closed in Years 2016-2019.
2. SR 408 under construction from Good Homes Road to Hiwassee Road in Years 2017-2018.
3. SR 408 / SR 417 Interchange under construction in Years 2016-2020, by projects 408-253 F/G.
4. SR 408 under construction in Years 2017-2019, from SR 417 to Alafaya Trail.
5. 2018-2022 AAWT volumes based on adopted seasonal factors, utilizing the 2016 and 2017 toll plaza transaction data.
6. SR 408 / I-4 Interchange ramps open to traffic in 2020.
7. 2016-2020 AAWT volumes Orange Avenue WB Off Ramp based on historical growth of corresponding ramp movement.



Mainline Volume Summary SR 408 (EAST-WEST EXPRESSWAY)

Existing and Historical Annual Average Weekday Mainline Traffic Volumes

Location	Year 2012	Year 2013	Year 2014	Year 2015	Year 2016	Year 2017	Year 2018	Year 2019	Year 2020	Year 2021	Year 2022
Bumby Avenue to Crystal Lake Drive	128,970	128,590	135,300	146,110	152,210	150,240	153,780	154,120	129,210	146,760	163,760
Crystal Lake Drive to Conway Road	138,810	136,320	144,420	157,950	165,780	164,400	169,570	169,120	140,280	159,260	178,160
Conway Road to Andes Avenue	127,170	125,460	132,760	144,880	152,970	151,490	151,300	156,140	128,900	146,130	163,700
Andes Avenue to SR 436 / Yucatan Drive	117,530	115,530	122,400	132,940	140,380	139,700	145,950	144,070	118,600	132,100	144,800
SR 436 / Yucatan Drive to Goldenrod Road/ Chickasaw Trail	114,450	116,930	123,510	131,920	139,480	137,400	146,110	144,470	116,810	132,100	143,770
Goldenrod Road/ Chickasaw Trail to SR 417 (Central FL GreeneWay)	102,280	103,730	109,630	117,270	124,240	121,780	125,530	127,110	103,060	115,780	127,970
SR 417 (Central FL GreeneWay) to Dean Road	76,500	75,280	78,960	84,230	89,950	87,660	85,840	85,180	68,290	75,930	85,960
Dean Road to Rouse Road	67,200	67,320	71,110	74,180	79,580	77,960	78,240	76,400	59,850	66,590	74,450
Rouse Road to Alafaya Trail	59,850	59,150	64,030	66,260	69,410	68,530	69,060	68,380	53,520	59,080	66,160
Alafaya Trail to SR 50 (Colonial Drive)	33,060	33,990	34,780	37,460	38,440	39,760	39,120	37,550	29,950	33,760	38,720

Notes:

1. SR 408 under construction in Years 2015-2020 at the Interstate 4 (I-4) Interchange (I-4 Ultimate). Orange Avenue WB On-ramp closed in Years 2016-2019.
2. SR 408 under construction from Good Homes Road to Hiawasse Road in Years 2017-2018.
3. SR 408 / SR 417 Interchange under construction in Years 2016-2020, by projects 408-253 F/G.
4. SR 408 under construction in Years 2017-2019, from SR 417 to Alafaya Trail.
5. 2018-2022 AAWT volumes based on adopted seasonal factors, utilizing the 2016 and 2017 toll plaza transaction data.
6. SR 408 / I-4 Interchange ramps open to traffic in 2020.
7. 2016-2020 AAWT volumes Orange Avenue WB Off Ramp based on historical growth of corresponding ramp movement.



Mainline Volume Summary - Continued SR 408 (EAST-WEST EXPRESSWAY)

Existing and Historical Annual Average Weekday Ramp Terminal Traffic Volumes

Ramp Location	Year 2012	Year 2013	Year 2014	Year 2015	Year 2016	Year 2017	Year 2018	Year 2019	Year 2020	Year 2021	Year 2022
Exit 1 : SR 50 / Clarke Road Spur											
Eastbound On-Ramp	5,310	5,050	5,510	5,600	5,580	4,930	5,310	6,100	5,000	5,390	6,280
Westbound Off-Ramp	4,490	4,330	4,450	4,840	4,670	4,510	4,670	5,070	3,850	4,330	5,370
Exit 2: Good Homes Road											
Eastbound Off-Ramp	3,430	3,690	4,010	4,630	5,300	5,660	5,840	5,800	4,430	4,870	5,170
Westbound On-Ramp	3,640	3,940	4,320	4,940	5,720	6,440	6,730	6,310	5,370	5,880	6,310
Eastbound On-Ramp	4,820	4,500	4,840	5,480	5,850	5,520	5,850	5,760	4,860	5,140	5,340
Westbound Off-Ramp	4,650	4,320	4,620	5,230	5,590	5,450	5,630	6,090	4,800	5,160	5,860
Exit 4 : Hiawasse Road											
Eastbound Off-Ramp	2,310	2,330	2,630	2,960	3,250	2,260	3,580	3,520	2,960	3,430	3,580
Westbound On-Ramp	2,160	2,240	2,550	2,960	3,350	3,720	4,140	3,740	3,180	3,690	3,650
Eastbound On-Ramp	4,810	4,920	5,410	5,990	6,190	6,280	6,300	6,060	5,490	6,350	6,640
Westbound Off-Ramp	4,290	4,270	4,780	5,000	5,210	5,740	5,580	5,560	4,870	5,560	6,110
Exit 5 : Kirkman Road											
Eastbound Off-Ramp	3,370	3,330	3,690	3,570	4,020	4,430	5,180	5,330	4,170	4,580	4,870
Westbound On-Ramp	3,110	3,210	3,510	3,720	4,220	4,480	4,910	4,820	3,940	4,440	4,440
Eastbound On-Ramp	6,170	7,740	6,180	6,760	6,770	6,640	6,580	5,840	4,460	5,350	5,350
Westbound Off-Ramp	5,320	6,550	5,440	5,840	6,140	5,870	6,680	6,190	4,080	5,070	5,160
Exit 6 : Pine Hills Road											
Eastbound On-Ramp	2,950	2,760	2,990	3,390	3,650	3,600	3,500	3,580	3,500	4,060	4,280
Westbound Off-Ramp	2,270	2,550	2,620	2,080	2,300	1,840	3,300	3,070	2,970	3,510	3,760
Exit 7 : Old Winter Garden Road											
Eastbound On-Ramp	1,750	1,880	2,130	2,230	2,490	2,690	2,890	3,090	2,700	2,920	2,960
Westbound Off-Ramp	1,910	2,050	2,280	2,540	2,790	3,060	2,970	3,370	2,910	3,260	3,370

Notes:

- SR 408 under construction in Years 2015-2020 at the Interstate 4 (I-4) Interchange (I-4 Ultimate). Orange Avenue WB On-ramp closed in Years 2016-2019.
- SR 408 under construction from Good Homes Road to Hiawasse Road in Years 2017-2018.
- SR 408 / SR 417 Interchange under construction in Years 2016-2020, by projects 408-253 F/G.
- SR 408 under construction in Years 2017-2019, from SR 417 to Alafaya Trail.
- 2018-2022 AAWT volumes based on adopted seasonal factors, utilizing the 2016 and 2017 toll plaza transaction data.
- SR 408 / I-4 Interchange ramps open to traffic in 2020.
- 2016-2020 AAWT volumes Orange Avenue WB Off Ramp based on historical growth of corresponding ramp movement.

Existing and Historical Annual Average Weekday Ramp Terminal Traffic Volumes

Ramp Location	Year 2012	Year 2013	Year 2014	Year 2015	Year 2016	Year 2017	Year 2018	Year 2019	Year 2020	Year 2021	Year 2022
Exit 8A : John Young Parkway											
Eastbound Off-Ramp	3,920	3,110	3,220	3,680	3,850	3,910	4,280	4,580	4,140	3,760	3,820
Westbound On-Ramp	3,620	3,420	3,740	4,320	4,700	4,630	4,720	4,240	3,860	4,140	4,440
Eastbound On-Ramp	5,540	5,310	5,680	6,660	6,740	6,800	6,750	5,900	5,530	5,770	5,900
Westbound Off-Ramp	4,210	4,240	4,320	4,690	4,700	4,850	5,080	4,520	4,000	4,410	5,760
Exit 8B : Tampa Avenue											
Eastbound Off-Ramp	870	880	1,030	1,210	1,660	1,900	2,240	2,250	1,730	1,920	2,440
Westbound On-Ramp	990	1,040	1,140	1,300	1,810	1,880	2,150	2,340	1,800	2,000	2,540
Exit 9 : Orange Blossom Trail (US 441)											
Eastbound Off-Ramp	2,600	2,570	2,770	3,130	3,690	3,720	3,680	3,950	3,330	3,460	3,420
Westbound On-Ramp	2,650	2,690	2,930	3,170	3,870	3,520	4,690	4,780	3,390	3,870	3,830
Eastbound On-Ramp	3,640	3,970	4,280	4,660	5,170	5,580	6,030	6,130	4,400	5,060	4,580
Westbound Off-Ramp	3,400	3,690	3,920	4,160	4,530	5,140	5,760	5,380	3,860	4,510	4,200
Exit 10A : Interstate 4											
SR 408 Eastbound Off-Ramp to WB I-4	3,160	2,470	3,390	3,330	3,270	3,840	4,310	2,410	3,670	4,750	7,100
SR 408 Eastbound Off-Ramp to EB I-4	7,940	7,510	7,640	7,440	7,240	8,580	10,750	7,580	7,480	9,610	11,920
SR 408 Westbound On-Ramp from WB I-4	-----	-----	-----	-----	-----	-----	-----	-----	7,210	9,260	12,180
SR 408 Westbound On-Ramp from EB I-4	-----	-----	-----	-----	-----	-----	-----	-----	3,090	4,000	5,970
SR 408 Westbound On-Ramp from I-4	7,560	7,340	8,280	9,205	10,130	9,320	10,780	11,000	-----	-----	-----
SR 408 Westbound Off-Ramp to WB I-4	22,900	21,490	21,630	22,020	22,410	18,170	22,170	21,870	22,800	21,690	26,910
SR 408 Westbound Off-Ramp to EB I-4	14,730	14,080	12,990	10,770	8,550	10,990	13,530	12,030	10,910	10,380	14,090
SR 408 Eastbound On-Ramp from WB I-4	-----	-----	-----	-----	-----	-----	-----	-----	11,530	14,540	19,730
SR 408 Eastbound On-Ramp from EB I-4	-----	-----	-----	-----	-----	-----	-----	-----	21,020	21,770	23,160
SR 408 Eastbound On-Ramp from I-4	30,890	29,950	33,780	36,185	38,590	28,670	29,080	23,510	-----	-----	-----

Notes:

1. SR 408 under construction in Years 2015-2020 at the Interstate 4 (I-4) Interchange (I-4 Ultimate). Orange Avenue WB On-ramp closed in Years 2016-2019.
2. SR 408 under construction from Good Homes Road to Hiwassee Road in Years 2017-2018.
3. SR 408 / SR 417 Interchange under construction in Years 2016-2020, by projects 408-253 F/G.
4. SR 408 under construction in Years 2017-2019, from SR 417 to Alafaya Trail.
5. 2018-2022 AAWT volumes based on adopted seasonal factors, utilizing the 2016 and 2017 toll plaza transaction data.
6. SR 408 / I-4 Interchange ramps open to traffic in 2020.
7. 2016-2020 AAWT volumes Orange Avenue WB Off Ramp based on historical growth of corresponding ramp movement.



Interchange - Ramp Volume Summary SR 408 (EAST-WEST EXPRESSWAY)

Existing and Historical Annual Average Weekday Ramp Terminal Traffic Volumes

Ramp Location	Year 2012	Year 2013	Year 2014	Year 2015	Year 2016	Year 2017	Year 2018	Year 2019	Year 2020	Year 2021	Year 2022
Exit 10B : Orange Avenue											
Eastbound Off-Ramp	6,930	6,800	6,820	7,320	7,270	7,530	7,580	6,280	4,300	4,640	5,940
Westbound On-Ramp	5,500	5,430	5,720	6,520	6,480	6,710	6,750	5,590	3,830	4,130	5,290
Exit 11A : Rosalind Avenue											
Eastbound On-Ramp	10,200	9,280	9,830	12,090	11,670	12,390	12,120	12,220	7,670	7,440	8,840
Westbound Off-Ramp	8,710	9,640	10,340	10,850	6,190	10,250	10,420	9,700	7,560	7,720	8,630
Exit 11B : Mills Avenue											
Eastbound Off-Ramp	1,080	1,080	1,200	1,430	1,570	1,610	1,650	1,640	1,740	2,520	2,680
Eastbound On-Ramp	4,300	4,510	5,300	5,590	6,250	6,160	6,880	6,680	4,130	5,530	5,880
Westbound Off-Ramp	5,020	4,070	4,260	4,420	4,820	5,370	4,930	5,270	3,640	3,490	3,640
Exit 12A : Bumby Avenue											
Eastbound Off-Ramp	5,330	5,180	5,580	6,300	6,380	6,800	7,030	6,970	6,560	7,390	8,370
Westbound On-Ramp	5,910	5,890	6,580	7,280	7,780	8,230	8,600	8,590	7,530	8,460	8,970
Exit 12B : Crystal Lake Drive											
Eastbound On-Ramp	4,910	4,920	5,590	5,890	6,530	6,800	7,240	7,060	5,250	5,820	5,870
Westbound Off-Ramp	4,930	5,600	6,210	6,760	7,330	8,010	8,650	7,630	6,050	6,860	8,120
Exit 13 : Conway Road											
Eastbound Off-Ramp	5,430	5,180	5,470	5,990	6,270	6,350	6,460	6,030	5,500	6,400	7,410
Westbound On-Ramp	6,210	5,680	6,190	6,280	6,680	7,010	6,870	6,710	5,880	6,730	7,800
Exit 14 : SR 436 / Andes Avenue											
Eastbound Off-Ramp to Andes Ave / SR 436	9,170	9,440	9,950	11,030	11,650	11,570	10,960	10,430	9,740	11,130	12,170
Westbound On-Ramp from SR 436 SB	5,350	5,450	5,870	6,790	7,270	6,810	6,850	6,490	6,350	7,070	7,680
Westbound On-Ramp from SR 436 NB	5,620	5,430	5,690	6,480	6,650	6,760	6,690	6,330	5,690	6,570	7,400
Eastbound On-Ramp from Yucatan Dr.	3,920	4,230	4,540	4,990	5,320	5,330	5,360	5,210	4,310	4,700	4,810
Westbound Off-Ramp to SR 436	3,970	4,510	5,030	5,600	5,860	5,870	6,250	6,240	5,390	5,860	5,990
Westbound On-Ramp from Andes Ave.	470	490	410	580	680	810	850	930	760	860	1,120

Notes:

1. SR 408 under construction in Years 2015-2020 at the Interstate 4 (I-4) Interchange (I-4 Ultimate). Orange Avenue WB On-ramp closed in Years 2016-2019.
2. SR 408 under construction from Good Homes Road to Hiawasse Road in Years 2017-2018.
3. SR 408 / SR 417 Interchange under construction in Years 2016-2020, by projects 408-253 F/G.
4. SR 408 under construction in Years 2017-2019, from SR 417 to Alafaya Trail.
5. 2018-2022 AAWT volumes based on adopted seasonal factors, utilizing the 2016 and 2017 toll plaza transaction data.
6. SR 408 / I-4 Interchange ramps open to traffic in 2020.
7. 2016-2020 AAWT volumes Orange Avenue WB Off Ramp based on historical growth of corresponding ramp movement.



Interchange - Ramp Volume Summary SR 408 (EAST-WEST EXPRESSWAY)

Existing and Historical Annual Average Weekday Ramp Terminal Traffic Volumes

Ramp Location	Year 2012	Year 2013	Year 2014	Year 2015	Year 2016	Year 2017	Year 2018	Year 2019	Year 2020	Year 2021	Year 2022
Exit 16 : Goldenrod Road (SR 551)											
Eastbound Off-Ramp	10,660	7,310	7,510	8,160	6,190	8,190	7,850	7,660	6,880	7,790	8,290
Westbound On-Ramp	11,040	6,800	7,210	7,570	7,770	7,720	7,350	7,260	6,540	7,210	7,310
Eastbound On-Ramp	4,580	4,900	5,510	6,040	6,570	6,340	6,200	6,130	4,850	5,320	5,480
Westbound Off-Ramp	4,950	5,370	5,570	6,210	6,550	7,580	6,370	6,160	4,980	5,580	5,880
Exit 17 : Chickasaw Trail											
Eastbound Off-Ramp	-----	4,850	5,510	5,700	6,610	6,720	6,750	6,310	4,860	5,340	5,950
Westbound On-Ramp	-----	4,320	4,750	5,550	6,440	7,580	6,820	6,590	5,270	5,760	6,400
Exit 18 : SR 417 (Central FL GreeneWay)											
Eastbound Off-Ramp to SB SR 417	7,310	7,530	8,620	9,880	11,040	10,690	13,380	14,410	12,330	13,200	14,700
Eastbound Off-Ramp to NB SR 417	15,090	15,450	16,160	17,540	18,470	18,730	18,570	18,200	14,830	16,400	18,360
Westbound On-Ramp from NB SR 417	8,170	8,190	8,180	10,520	11,910	11,350	14,030	14,840	12,700	13,590	15,140
Westbound On-Ramp from SB SR 417	15,290	15,590	15,980	16,970	18,080	18,450	18,630	19,000	14,360	17,400	19,490
Eastbound On-Ramp from NB SR 417	6,340	6,040	6,030	7,230	7,660	8,180	9,240	9,910	6,690	7,380	8,220
Eastbound On-Ramp from SB SR 417	3,480	3,430	3,740	4,000	4,590	4,790	5,000	4,680	3,610	3,900	4,050
Westbound Off-Ramp to NB SR 417	3,410	3,590	3,870	4,250	4,770	4,920	4,740	4,590	3,700	4,070	4,230
Westbound Off-Ramp to SB SR 417	6,850	5,830	6,210	7,130	7,780	8,550	8,710	9,330	6,270	8,270	9,210
Exit 19 : Dean Road											
Eastbound Off-Ramp	5,560	5,300	4,870	5,490	5,940	5,990	6,140	6,290	4,880	6,050	6,160
Westbound On-Ramp	6,120	5,980	5,750	6,280	7,050	7,490	7,370	7,070	5,490	6,840	6,960
Eastbound On-Ramp	1,270	1,560	1,430	1,440	1,760	1,570	1,610	1,240	1,020	1,100	1,210
Westbound Off-Ramp	1,110	1,090	1,380	1,420	1,680	1,400	1,430	1,330	890	970	1,030

Notes:

1. SR 408 under construction in Years 2015-2020 at the Interstate 4 (I-4) Interchange (I-4 Ultimate). Orange Avenue WB On-ramp closed in Years 2016-2019.
2. SR 408 under construction from Good Homes Road to Hiawasse Road in Years 2017-2018.
3. SR 408 / SR 417 Interchange under construction in Years 2016-2020, by projects 408-253 F/G.
4. SR 408 under construction in Years 2017-2019, from SR 417 to Alafaya Trail.
5. 2018-2022 AAWT volumes based on adopted seasonal factors, utilizing the 2016 and 2017 toll plaza transaction data.
6. SR 408 / I-4 Interchange ramps open to traffic in 2020.
7. 2016-2020 AAWT volumes Orange Avenue WB Off Ramp based on historical growth of corresponding ramp movement.



Interchange - Ramp Volume Summary SR 408 (EAST-WEST EXPRESSWAY)

SECTION II

12

Existing and Historical Annual Average Weekday Ramp Terminal Traffic Volumes

Ramp Location	Year 2012	Year 2013	Year 2014	Year 2015	Year 2016	Year 2017	Year 2018	Year 2019	Year 2020	Year 2021	Year 2022
Exit 20 : Rouse Road											
Eastbound Off-Ramp	4,790	4,410	5,290	5,670	5,990	5,950	5,930	5,730	4,090	4,530	5,190
Westbound On-Ramp	3,720	3,730	4,400	4,800	5,750	5,330	5,310	5,860	3,290	3,650	4,150
Eastbound On-Ramp	610	670	730	740	830	710	850	770	410	430	500
Westbound Off-Ramp	550	550	650	720	760	680	880	640	450	500	530
Exit 21: Alafaya Trail											
Eastbound Off-Ramp	13,240	12,430	13,600	14,640	15,150	14,430	13,340	12,370	11,100	12,290	13,050
Westbound On-Ramp	13,550	12,730	14,660	15,330	16,000	15,520	14,230	12,040	11,820	13,070	14,210
Exit 23 : SR 50 (East Colonial Drive)											
Eastbound Off-Ramp	11,200	11,700	11,900	12,900	12,070	13,210	13,720	13,570	12,080	13,170	13,980
Westbound On-Ramp from EB SR 50	1,290	1,430	1,570	2,040	2,210	2,230	2,270	2,090	1,920	2,150	2,280
Westbound On Ramp from WB SR 50	10,300	9,930	9,970	10,890	10,360	12,250	12,160	10,680	10,480	10,740	8,770

Notes:

1. SR 408 under construction in Years 2015-2020 at the Interstate 4 (I-4) Interchange (I-4 Ultimate). Orange Avenue WB On-ramp closed in Years 2016-2019.
2. SR 408 under construction from Good Homes Road to Hiawasse Road in Years 2017-2018.
3. SR 408 / SR 417 Interchange under construction in Years 2016-2020, by projects 408-253 F/G.
4. SR 408 under construction in Years 2017-2019, from SR 417 to Alafaya Trail.
5. 2018-2022 AAWT volumes based on adopted seasonal factors, utilizing the 2016 and 2017 toll plaza transaction data.
6. SR 408 / I-4 Interchange ramps open to traffic in 2020.
7. 2016-2020 AAWT volumes Orange Avenue WB Off Ramp based on historical growth of corresponding ramp movement.



Interchange - Ramp Volume Summary SR 408 (EAST-WEST EXPRESSWAY)

Beachline Expressway



Existing and Historical Annual Average Weekday Mainline Traffic Volumes

Location	Year 2012	Year 2013	Year 2014	Year 2015	Year 2016	Year 2017	Year 2018	Year 2019	Year 2020	Year 2021	Year 2022
Boggy Creek Road to Tradeport Drive	94,310	92,200	98,510	104,530	110,540	109,140	113,060	118,800	81,130	100,530	124,770
Tradeport Drive to SR 436 (Semoran Boulevard)	80,840	80,730	83,820	91,280	98,740	109,020	113,680	118,300	81,510	100,830	125,380
SR 436 (Semoran Boulevard) to Goldenrod Road	68,610	71,910	73,760	79,710	85,770	93,500	99,670	100,710	74,680	86,000	97,240
Goldenrod Road to Narcoossee Road	69,920	73,700	75,190	81,920	89,020	97,000	103,400	105,750	75,340	86,600	97,950
Narcoossee Road to SR 417 (Central FL GreeneWay)	54,280	58,270	60,730	65,110	70,470	76,630	81,510	84,590	60,920	71,530	75,740
SR 417 (Central FL GreeneWay) to Sunbridge Parkway / Innovation Way	48,430	49,230	53,510	56,120	60,710	64,640	70,090	70,270	54,990	63,240	70,700
Sunbridge Parkway/ Innovation Way to Dallas Boulevard	41,910	43,390	46,460	49,590	52,470	56,090	59,730	61,120	47,340	57,190	62,840
Dallas Boulevard to SR 520	38,360	39,190	40,890	45,530	46,880	50,590	54,080	55,040	42,330	52,180	57,630

Notes:

1. SR 528 under construction in the Year 2013 for bridge deck replacements at Tradeport Drive, Daetwyler Drive and Via Flora Drive.
2. SR 528 under construction in the Years 2015-2016 for the Airport Mainline Toll Plaza removal and roadway widening from Boggy Creek Road to SR 436.
3. SR 528 Innovation Way interchange construction and ICP interchange removal in Years 2017-2018.
4. 2018-2022 AAWT volumes based on adopted seasonal factors, utilizing the 2016 and 2017 toll plaza transaction data.
5. SR 528 under construction in the Years 2020-2022 for SR 436 interchange reconstruction.
6. SR 528 under construction in the Year 2022 for widening from Narcoossee Rd to SR 417.



Mainline Volume Summary SR 528 (BEACHLINE EXPRESSWAY)

Existing and Historical Annual Average Weekday Ramp Terminal Traffic Volumes

Ramp Location	Year 2012	Year 2013	Year 2014	Year 2015	Year 2016	Year 2017	Year 2018	Year 2019	Year 2020	Year 2021	Year 2022
Exit 8 : Boggy Creek Road											
Eastbound On-Ramp	15,350	11,790	12,710	11,990	11,260	11,540	11,740	11,730	8,010	9,600	10,540
Westbound Off-Ramp	12,080	10,960	11,570	10,610	9,650	10,400	10,560	10,480	9,020	9,090	9,730
Exit 9 : Tradeport Drive / Conway Road											
Eastbound Off-Ramp	10,680	9,180	9,670	9,820	9,970	4,430	5,050	5,040	3,780	4,880	5,600
Westbound On-Ramp	7,480	5,690	7,020	7,160	7,300	3,590	3,760	3,960	2,860	3,690	4,190
Eastbound On-Ramp	2,730	2,730	2,790	3,230	3,660	4,020	4,680	4,610	3,590	4,680	5,160
Westbound Off-Ramp	1,960	2,420	2,240	2,410	2,580	2,940	3,370	4,060	2,990	4,520	5,120
Exit 11 : SR 436 (Semoran Boulevard)											
Eastbound Off-Ramp to NB SR 436	4,960	4,740	3,440	5,560	6,870	7,280	7,350	7,190	5,580	6,420	8,100
Eastbound Off-Ramp to SB SR 436	14,200	13,010	14,830	16,150	17,600	18,120	18,280	17,910	8,270	15,980	22,540
Westbound On-Ramp from NB SR 436	13,130	11,970	11,780	14,310	14,580	16,160	16,460	17,490	8,370	11,320	21,380
Westbound On-Ramp from SB SR 436	6,350	6,080	6,110	6,520	6,930	8,130	8,430	8,640	6,710	9,060	10,780
Eastbound On-Ramp from NB SR 436	7,580	7,860	7,560	9,220	9,290	10,380	11,720	11,870	6,800	11,450	11,600
Eastbound On-Ramp from SB SR 436	5,030	5,370	5,340	5,720	6,300	6,700	7,570	7,720	4,570	6,080	6,240
Westbound Off-Ramp to NB SR 436	5,750	5,680	5,960	6,470	6,930	7,020	7,840	7,270	4,770	5,720	5,870
Westbound Off-Ramp to SB SR 436	8,050	7,990	7,400	9,110	9,340	10,340	11,750	11,800	7,010	9,800	10,980

Notes:

- | | |
|---|---|
| <ol style="list-style-type: none"> 1. SR 528 under construction in the Year 2013 for bridge deck replacements at Tradeport Drive, Daetwyler Drive and Via Flora Drive. 2. SR 528 under construction in the Years 2015-2016 for the Airport Mainline Toll Plaza removal and roadway widening from Boggy Creek Road to SR 436. 3. SR 528 Innovation Way interchange construction and ICP interchange removal in Years 2017-2018. | <ol style="list-style-type: none"> 4. 2018-2022 AAWT volumes based on adopted seasonal factors, utilizing the 2016 and 2017 toll plaza transaction data. 5. SR 528 under construction in the Years 2020-2022 for SR 436 interchange reconstruction. 6. SR 528 under construction in the Year 2022 for widening from Narcoossee Rd to SR 417. |
|---|---|



Interchange - Ramp Volume Summary SR 528 (BEACHLINE EXPRESSWAY)

Existing and Historical Annual Average Weekday Ramp Terminal Traffic Volumes

Ramp Location	Year 2012	Year 2013	Year 2014	Year 2015	Year 2016	Year 2017	Year 2018	Year 2019	Year 2020	Year 2021	Year 2022
Exit 12 : Goldenrod Road											
Eastbound Off-Ramp	2,470	2,390	2,890	2,780	3,390	3,690	3,510	3,480	2,820	3,670	3,950
Westbound On-Ramp from SB Goldenrod Road	1,630	1,990	2,070	2,030	2,560	2,760	2,900	3,050	2,660	3,140	3,320
Westbound On-Ramp from NB Goldenrod Road	620	560	670	810	830	850	830	830	430	840	1,120
Eastbound On-Ramp	3,130	3,250	3,450	3,700	4,870	5,370	5,780	5,980	3,050	3,740	4,960
Westbound Off-Ramp	2,900	2,990	3,110	3,160	4,200	4,560	5,110	5,510	3,010	3,330	4,900
Exit 13 : Narcoossee Road											
Eastbound Off-Ramp	10,690	10,840	11,280	11,610	13,140	14,000	15,120	15,190	10,940	15,550	17,100
Westbound On-Ramp	10,610	10,750	10,680	11,100	12,460	13,320	14,410	14,170	10,540	11,330	12,470
Eastbound On-Ramp	2,970	2,960	3,420	3,560	3,940	3,970	4,190	4,300	3,600	3,900	3,990
Westbound Off-Ramp	2,690	3,230	3,110	3,270	3,490	3,180	3,370	3,610	2,900	3,250	3,370
Exit 16 : SR 417 (Central FL GreeneWay)											
Eastbound Off-Ramp to NB SR 417	13,410	12,750	13,960	13,800	15,700	17,190	18,890	19,430	13,460	15,390	17,350
Eastbound Off-Ramp to SB SR 417	800	950	1,220	1,410	1,820	2,380	2,820	2,720	1,860	2,010	2,230
Westbound On-Ramp from NB SR 417	1,030	1,150	1,560	1,610	1,820	2,200	2,310	2,420	2,070	2,600	2,890
Westbound On-Ramp from SB SR 417	13,660	12,740	13,450	13,950	15,340	16,690	16,930	18,730	11,790	13,530	16,350
Eastbound On-Ramp from NB SR 417	3,480	3,790	4,380	4,540	5,990	6,910	6,790	7,590	7,450	9,200	10,160
Eastbound On-Ramp from SB SR 417	5,500	5,180	5,720	5,980	6,700	6,670	7,700	6,910	5,480	6,840	7,500
Westbound Off-Ramp to NB SR 417	5,730	5,890	6,250	6,370	7,180	6,920	7,620	7,780	6,630	6,720	7,370
Westbound Off-Ramp to SB SR 417	3,590	3,860	4,420	5,020	6,000	6,740	7,910	7,820	6,680	7,610	8,410

Notes:

1. SR 528 under construction in the Year 2013 for bridge deck replacements at Tradeport Drive, Daetwyler Drive and Via Flora Drive.
2. SR 528 under construction in the Years 2015-2016 for the Airport Mainline Toll Plaza removal and roadway widening from Boggy Creek Road to SR 436.
3. SR 528 Innovation Way interchange construction and ICP interchange removal in Years 2017-2018.
4. 2018-2022 AAWT volumes based on adopted seasonal factors, utilizing the 2016 and 2017 toll plaza transaction data.
5. SR 528 under construction in the Years 2020-2022 for SR 436 interchange reconstruction.
6. SR 528 under construction in the Year 2022 for widening from Narcoossee Rd to SR 417.



Interchange - Ramp Volume Summary SR 528 (BEACHLINE EXPRESSWAY)

Existing and Historical Annual Average Weekday Ramp Terminal Traffic Volumes

Ramp Location	Year 2012	Year 2013	Year 2014	Year 2015	Year 2016	Year 2017	Year 2018	Year 2019	Year 2020	Year 2021	Year 2022
Exit 19 : Sunbridge Parkway / Innovation Way											
Eastbound Off-Ramp	3,710	4,020	4,740	4,830	4,920	5,700	5,620	5,570	4,510	4,760	5,320
Westbound On-Ramp	3,950	4,500	4,260	4,840	5,410	6,120	5,760	5,470	4,270	4,530	5,180
Westbound On-Loop Ramp	-----	-----	-----	-----	-----	-----	890	880	760	760	990
Eastbound On-Ramp	580	750	890	900	1,020	1,200	920	860	800	860	880
Westbound Off-Ramp	560	690	780	850	1,030	1,090	1,070	1,050	880	970	990
Exit 24 : Dallas Boulevard											
Eastbound Off-Ramp	1,620	1,870	1,950	1,970	2,610	2,690	2,780	2,520	2,360	2,540	2,800
Westbound On-Ramp	1,930	2,150	2,270	2,210	2,930	2,960	3,070	2,860	2,620	2,790	3,160
Exit 31 : SR 520											
Eastbound Off-Ramp	4,480	4,240	4,520	4,590	4,600	6,130	5,040	5,060	4,020	4,720	4,530
Westbound On-Ramp	3,920	3,730	3,610	3,820	3,820	5,220	3,860	3,820	3,130	3,500	3,290

Notes:

1. SR 528 under construction in the Year 2013 for bridge deck replacements at Tradeport Drive, Daetwyler Drive and Via Flora Drive.
2. SR 528 under construction in the Years 2015-2016 for the Airport Mainline Toll Plaza removal and roadway widening from Boggy Creek Road to SR 436.
3. SR 528 Innovation Way interchange construction and ICP interchange removal in Years 2017-2018.
4. 2018-2022 AAWT volumes based on adopted seasonal factors, utilizing the 2016 and 2017 toll plaza transaction data.
5. SR 528 under construction in the Years 2020-2022 for SR 436 interchange reconstruction.
6. SR 528 under construction in the Year 2022 for widening from Narcoossee Rd to SR 417.



Interchange - Ramp Volume Summary SR 528 (BEACHLINE EXPRESSWAY)

Central Florida GreeneWay



2022 Traffic Data and Statistics Manual
CENTRAL FLORIDA EXPRESSWAY AUTHORITY

Existing and Historical Annual Average Weekday Mainline Traffic Volumes

Location	Year 2012	Year 2013	Year 2014	Year 2015	Year 2016	Year 2017	Year 2018	Year 2019	Year 2020	Year 2021	Year 2022
International Drive to John Young Parkway	41,300	41,840	44,780	51,500	62,150	75,150	79,070	79,710	47,650	67,590	78,510
John Young Parkway to Orange Blossom Trail	40,610	41,850	45,940	53,210	64,650	79,200	83,680	85,160	54,870	70,570	87,630
Orange Blossom Trail to Florida's Turnpike	38,170	39,850	44,260	51,780	63,880	78,840	83,670	85,380	56,620	71,470	90,270
Florida's Turnpike to Landstar Boulevard	38,170	39,850	44,260	57,230	70,150	86,230	92,530	94,200	65,570	82,990	95,360
Landstar Boulevard to South Access (OIA)/ Boggy Creek Road	38,350	40,300	44,880	54,580	66,700	76,520	81,960	84,070	57,680	70,740	80,090
South Access (OIA)/ Boggy Creek Road to Lake Nona Boulevard	30,790	32,610	39,110	46,140	51,490	61,260	67,410	68,540	52,650	59,630	66,710
Lake Nona Boulevard to Narcoossee Road	29,930	33,500	38,020	44,980	53,040	61,070	67,080	67,680	51,470	58,770	64,370
Narcoossee Road to Moss Park Road	30,940	35,250	40,480	48,510	57,750	65,750	73,440	74,960	58,540	67,030	73,780
Moss Park Road to Innovation Way/ Dowden Road	35,670	40,170	45,600	54,310	64,230	72,160	80,550	80,900	63,040	71,690	73,610
Innovation Way/ Dowden Road to SR 528 (Beachline Expressway)	36,080	39,720	46,230	55,650	64,860	73,930	82,300	83,710	65,240	74,500	77,160
SR 528 (Beachline Expressway) to Lee Vista Boulevard	62,600	64,910	70,860	82,510	94,850	103,010	112,660	115,240	84,810	95,810	106,290

Notes:

1. 24 hour machine counts were used for SR 417 NB Off-Ramp to Florida's Turnpike and SR 417 SB Off-Ramp to Florida's Turnpike in 2017.
2. Exit 17A, South Access Road opened in 2016.
3. In May 2016, Florida's Turnpike southbound off-ramp to northbound Florida's Turnpike and SR 417 northbound off-ramps to Florida's Turnpike opened.
4. SR 417 under construction in the Years 2018-2021 from SR 50 to the Orange/Seminole County Line.
5. 2018-2022 AAWT volumes based on adopted seasonal factors, utilizing the 2016 and 2017 toll plaza transaction data.
6. SR 417 under construction from International Drive to SR 528 in the years 2021-2022.
7. SR 417 NB on-ramp from SB Florida's Turnpike and SR 417 SB on-ramp from NB/SB Florida's Turnpike opened in 2021.



Mainline Volume Summary SR 417 (CENTRAL FLORIDA GREENEWAY)

Location	Year 2012	Year 2013	Year 2014	Year 2015	Year 2016	Year 2017	Year 2018	Year 2019	Year 2020	Year 2021	Year 2022
Lee Vista Boulevard to Curry Ford Road	64,950	66,575	73,770	86,030	97,280	104,190	114,070	117,000	86,420	96,810	105,860
Curry Ford Road to SR 408/417 Systems Interchange	61,640	65,080	69,700	83,390	90,030	94,500	107,500	109,760	82,720	91,980	101,070
SR 408/417 Systems Interchange to SR 50 (Colonial Drive)	74,720	73,840	76,920	89,760	98,570	103,480	108,510	108,840	79,520	88,770	96,590
SR 50 (Colonial Drive) to University Boulevard	-----	71,670	-----	86,650	95,670	100,740	105,980	104,670	78,840	87,450	92,330
University Boulevard to Orange / Seminole County Line	56,300	58,140	61,680	70,500	78,110	84,260	88,120	87,170	68,830	74,970	79,150

Notes:

- 24 hour machine counts were used for SR 417 NB Off-Ramp to Florida's Turnpike and SR 417 SB Off-Ramp to Florida's Turnpike in 2017.
- Exit 17A, South Access Road opened in 2016.
- In May 2016, Florida's Turnpike southbound off-ramp to northbound Florida's Turnpike and SR 417 northbound off-ramps to Florida's Turnpike opened.
- SR 417 under construction in the Years 2018-2021 from SR 50 to the Orange/Seminole County Line.
- 2018-2022 AAWT volumes based on adopted seasonal factors, utilizing the 2016 and 2017 toll plaza transaction data.
- SR 417 under construction from International Drive to SR 528 in the years 2021-2022.
- SR 417 NB on-ramp from SB Florida's Turnpike and SR 417 SB on-ramp from NB/SB Florida's Turnpike opened in 2021.



Mainline Volume Summary

SR 417 (CENTRAL FLORIDA GREENEWAY)

Existing and Historical Annual Average Weekday Ramp Terminal Traffic Volumes

Ramp Location	Year 2012	Year 2013	Year 2014	Year 2015	Year 2016	Year 2017	Year 2018	Year 2019	Year 2020	Year 2021	Year 2022
Exit 6 : International Drive											
Northbound On-Ramp	9,850	10,160	11,230	11,890	13,840	15,820	16,410	15,490	9,350	12,155	15,120
Southbound Off-Ramp	10,270	10,270	10,700	11,980	13,490	14,720	15,270	14,580	8,130	10,490	13,150
Exit 10 : John Young Parkway											
Northbound Off-Ramp	4,270	4,150	4,230	4,500	5,170	5,220	5,280	5,160	3,230	6,610	7,050
Southbound On-Ramp	4,020	4,010	4,060	4,260	4,626	4,950	5,320	5,010	3,060	4,000	4,260
Northbound On-Ramp	3,890	4,080	4,830	5,270	5,930	8,910	10,180	10,300	8,660	10,200	11,710
Southbound Off-Ramp	2,320	2,460	2,850	3,000	3,440	5,540	5,810	5,590	4,710	5,640	7,980
Southbound Off-Ramp to NB JYP	-----	-----	-----	-----	-----	2,080	2,180	2,100	1,610	2,650	2,910
Southbound Off-Ramp to SB JYP	-----	-----	-----	-----	-----	3,460	3,630	3,490	3,100	5,060	5,070
Exit 11 : US 17-92 / US 441											
Northbound Off-Ramp	3,840	3,930	4,250	4,520	5,210	5,080	5,160	5,500	3,280	5,060	4,820
Southbound On-Ramp	4,420	4,430	4,630	4,930	5,520	5,700	6,020	6,160	3,870	4,650	5,200
Northbound On-Ramp	2,740	3,070	3,350	3,690	4,160	5,570	6,080	6,220	4,960	5,620	6,430
Southbound Off-Ramp	3,080	3,400	3,870	4,210	4,810	4,950	5,110	4,990	4,040	4,710	5,380
Exit 12 : Florida's Turnpike											
Northbound Off-Ramp to NB Turnpike	-----	-----	-----	-----	-----	3,370	4,930	4,370	2,940	3,650	3,980
Northbound Off-Ramp to SB Turnpike	-----	-----	-----	-----	-----	5,860	7,120	7,170	6,650	7,890	9,530
Northbound On-Ramp from NB Turnpike	-----	-----	-----	3,120	4,030	7,110	8,520	8,690	8,000	6,660	8,320
Southbound Off-Ramp to NB Turnpike	-----	-----	-----	-----	-----	6,150	7,740	7,850	7,290	7,160	8,980
Southbound Off-Ramp to SB Turnpike	-----	-----	-----	2,580	3,330	4,200	4,820	4,730	4,640	4,760	5,950
Southbound On-Ramp from SB Turnpike	-----	-----	-----	-----	-----	-----	-----	-----	-----	3,000	2,760
Northbound On-Ramp from SB Turnpike	-----	-----	-----	-----	-----	6,150	7,740	7,850	7,290	7,160	9,090
Southbound On-Ramp from NB Turnpike	-----	-----	-----	-----	-----	-----	-----	-----	-----	8,670	10,480

Notes:

1. 24 hour machine counts were used for SR 417 NB Off-Ramp to Florida's Turnpike and SR 417 SB Off-Ramp to Florida's Turnpike in 2017.
2. Exit 17A, South Access Road opened in 2016.
3. In May 2016, Florida's Turnpike southbound off-ramp to northbound Florida's Turnpike and SR 417 northbound off-ramps to Florida's Turnpike opened.
4. SR 417 under construction in the Years 2018-2021 from SR 50 to the Orange/Seminole County Line.
5. 2018-2022 AAWT volumes based on adopted seasonal factors, utilizing the 2016 and 2017 toll plaza transaction data.
6. SR 417 under construction from International Drive to SR 528 in the years 2021-2022.
7. SR 417 NB on-ramp from SB Florida's Turnpike and SR 417 SB on-ramp from NB/SB Florida's Turnpike opened in 2021.



Interchange - Ramp Volume Summary SR 417 (CENTRAL FLORIDA GREENEWAY)

SECTION II

Existing and Historical Annual Average Weekday Ramp Terminal Traffic Volumes

Ramp Location	Year 2012	Year 2013	Year 2014	Year 2015	Year 2016	Year 2017	Year 2018	Year 2019	Year 2020	Year 2021	Year 2022
Exit 14 : Landstar Boulevard											
Northbound Off-Ramp	3,010	3,210	3,750	5,500	6,520	7,550	7,780	7,660	6,360	7,870	7,430
Southbound On-Ramp	3,490	3,560	4,090	5,840	6,870	10,560	11,340	11,380	9,270	11,170	10,550
Northbound On-Ramp	3,380	3,540	3,940	3,980	4,130	4,070	4,230	4,420	3,630	3,840	4,240
Southbound Off-Ramp	3,300	3,560	3,990	4,140	4,510	4,200	4,200	4,740	3,730	4,010	4,160
Exit 17A : International Airport (South Access Road)											
Northbound Off-Ramp	-----	-----	-----	-----	8,490	9,540	9,860	10,030	4,520	7,390	12,590
Southbound On-Ramp	-----	-----	-----	-----	9,180	9,450	10,160	10,520	4,580	7,590	12,930
Northbound On-Ramp	-----	-----	-----	-----	590	1,030	1,860	1,840	1,240	2,100	5,800
Southbound Off-Ramp	-----	-----	-----	-----	770	830	1,030	1,140	770	910	1,280
NB Ramp from Boggy Creek to South Access Rd	-----	-----	-----	-----	-----	10,440	10,730	10,850	11,930	9,310	9,800
SB Ramp from Boggy Creek to South Access Road	-----	-----	-----	-----	-----	11,110	11,350	11,700	13,270	9,790	10,300
Exit 17B : Boggy Creek Road											
Northbound Off-Ramp	6,210	5,630	5,840	7,680	2,120	2,470	2,860	2,880	2,940	3,370	4,850
Southbound On-Ramp	6,950	6,670	6,610	8,390	2,070	3,940	4,010	4,010	3,890	4,500	5,600
Northbound On-Ramp	2,950	3,430	3,700	4,020	3,490	3,630	4,440	4,620	4,490	4,730	4,830
Southbound Off-Ramp	2,650	3,030	3,410	3,700	3,300	3,850	4,610	4,620	4,590	4,760	4,860
Exit 19 : Lake Nona Boulevard											
Northbound Off-Ramp	1,740	2,000	2,500	3,020	3,460	3,720	4,560	5,040	4,250	4,950	6,260
Southbound On-Ramp	1,770	1,870	2,460	2,880	3,120	3,570	4,370	4,870	4,100	4,930	6,230
Northbound On-Ramp	1,320	1,510	2,080	2,990	3,570	3,700	4,390	4,610	3,670	4,480	4,960
Southbound Off-Ramp	1,330	1,500	2,040	2,910	3,400	3,620	4,380	4,680	3,690	4,630	5,180

Notes:

1. 24 hour machine counts were used for SR 417 NB Off-Ramp to Florida's Turnpike and SR 417 SB Off-Ramp to Florida's Turnpike in 2017.
2. Exit 17A, South Access Road opened in 2016.
3. In May 2016, Florida's Turnpike southbound off-ramp to northbound Florida's Turnpike and SR 417 northbound off-ramps to Florida's Turnpike opened.
4. SR 417 under construction in the Years 2018-2021 from SR 50 to the Orange/Seminole County Line.
5. 2018-2022 AAWT volumes based on adopted seasonal factors, utilizing the 2016 and 2017 toll plaza transaction data.
6. SR 417 under construction from International Drive to SR 528 in the years 2021-2022.
7. SR 417 NB on-ramp from SB Florida's Turnpike and SR 417 SB on-ramp from NB/SB Florida's Turnpike opened in 2021.



Interchange - Ramp Volume Summary SR 417 (CENTRAL FLORIDA GREENEWAY)

SECTION II

23

Existing and Historical Annual Average Weekday Ramp Terminal Traffic Volumes

Ramp Location	Year 2012	Year 2013	Year 2014	Year 2015	Year 2016	Year 2017	Year 2018	Year 2019	Year 2020	Year 2021	Year 2022
Exit 22 : Narcoossee Road											
Northbound Off-Ramp	3,120	3,400	3,920	3,960	4,260	5,660	5,670	5,650	4,770	5,360	6,230
Southbound On-Ramp	3,070	3,270	3,850	4,220	4,470	5,620	6,180	6,190	5,570	5,930	6,250
Northbound On-Ramp	3,710	4,420	5,400	6,140	6,840	7,740	9,220	9,630	8,590	9,750	10,910
Southbound Off-Ramp	3,490	4,140	5,000	5,600	6,440	7,610	9,120	9,380	8,720	9,820	10,990
Exit 23 : Moss Park Road											
Northbound Off-Ramp	-----	770	840	940	1,100	1,340	1,460	1,660	1,490	1,720	4,400
Southbound On-Ramp	-----	770	860	980	1,090	1,470	1,740	1,890	1,740	2,100	5,070
Northbound On-Ramp	3,030	3,190	3,430	3,620	3,950	4,170	4,770	4,310	3,420	3,970	4,420
Southbound Off-Ramp	3,260	3,220	3,470	3,830	4,320	4,800	5,350	4,850	3,720	4,380	4,870
Exit 24 : Dowden Road											
Northbound Off-Ramp	230	300	480	710	885	1,110	1,810	1,380	1,410	1,680	1,950
Southbound On-Ramp	200	360	590	890	1,130	1,200	2,100	1,720	1,580	1,890	2,110
Northbound On-Ramp	340	670	950	1,280	1,500	1,990	2,550	3,210	2,770	3,130	3,370
Southbound Off-Ramp	500	810	1,180	1,650	2,020	2,410	3,490	3,410	3,580	4,040	4,470
Exit 26 : Beachline Expressway (SR 528)											
Northbound Off-Ramp to EB SR 528	3,480	3,790	4,380	4,540	5,990	6,910	6,810	7,560	7,450	9,200	10,160
Northbound Off-Ramp to WB SR 528	1,030	1,150	1,560	1,610	1,820	2,200	2,290	2,420	2,070	2,600	2,890
Southbound On-Ramp from EB SR 528	800	950	1,220	1,410	1,820	2,380	2,800	2,710	1,860	2,010	2,230
Southbound On-Ramp from WB SR 528	3,590	3,860	4,420	5,020	6,000	6,740	7,860	7,800	6,680	7,610	8,410
Northbound On-Ramp from EB SR 528	13,410	12,750	13,960	13,800	15,700	17,190	18,780	19,370	13,460	15,390	17,350
Northbound On-Ramp from WB SR 528	5,730	5,890	6,250	6,370	7,180	6,920	7,570	7,750	6,630	6,720	7,370
Southbound Off-Ramp to EB SR 528	5,500	5,180	5,720	5,980	6,700	6,670	7,650	6,890	5,480	6,840	7,500
Southbound Off-Ramp to WB SR 528	13,660	12,740	13,450	13,950	15,340	16,690	16,830	18,680	11,790	13,530	16,350

Notes:

1. 24 hour machine counts were used for SR 417 NB Off-Ramp to Florida's Turnpike and SR 417 SB Off-Ramp to Florida's Turnpike in 2017.
2. Exit 17A, South Access Road opened in 2016.
3. In May 2016, Florida's Turnpike southbound off-ramp to northbound Florida's Turnpike and SR 417 northbound off-ramps to Florida's Turnpike opened.
4. SR 417 under construction in the Years 2018-2021 from SR 50 to the Orange/Seminole County Line.
5. 2018-2022 AAWT volumes based on adopted seasonal factors, utilizing the 2016 and 2017 toll plaza transaction data.
6. SR 417 under construction from International Drive to SR 528 in the years 2021-2022.
7. SR 417 NB on-ramp from SB Florida's Turnpike and SR 417 SB on-ramp from NB/SB Florida's Turnpike opened in 2021.



Interchange - Ramp Volume Summary SR 417 (CENTRAL FLORIDA GREENEWAY)

Existing and Historical Annual Average Weekday Ramp Terminal Traffic Volumes

Ramp Location	Year 2012	Year 2013	Year 2014	Year 2015	Year 2016	Year 2017	Year 2018	Year 2019	Year 2020	Year 2021	Year 2022
Exit 27 : Lee Vista Boulevard											
Northbound Off-Ramp	1,140	1,180	1,440	1,580	2,020	2,260	2,350	2,200	2,230	3,050	4,120
Southbound On-Ramp	1,280	1,270	1,670	1,860	2,160	2,340	2,520	2,440	2,280	3,140	3,980
Northbound On-Ramp	2,460	2,490	2,640	2,680	3,050	4,320	3,650	3,530	2,900	3,340	3,860
Southbound Off-Ramp	2,310	2,420	2,620	2,680	3,030	3,020	3,300	3,180	2,760	3,030	3,580
Exit 30 : Curry Ford Road											
Northbound Off-Ramp	5,690	5,530	6,230	7,100	8,940	9,290	9,480	8,380	6,210	6,330	6,700
Southbound On-Ramp	6,070	5,130	5,490	5,890	6,820	7,770	8,260	7,480	5,580	5,690	6,800
Northbound On-Ramp	4,380	4,170	4,440	4,650	4,860	4,720	5,120	4,920	4,190	4,570	5,150
Southbound Off-Ramp	4,070	3,820	4,230	4,520	4,810	4,610	5,030	4,670	4,150	4,410	4,970
Exit 33A&B : SR 408 (East-West Expressway)											
Northbound Off-Ramp to EB SR 408	6,340	6,040	6,030	7,230	7,660	8,180	9,340	9,910	6,690	7,380	8,220
Northbound Off-Ramp to WB SR 408	8,170	8,190	8,180	10,520	11,910	11,350	14,190	14,840	12,700	13,590	15,140
Southbound On-Ramp from EB SR 408	7,310	7,530	8,620	9,880	11,040	10,690	13,530	14,410	12,330	13,200	14,700
Southbound On-Ramp from WB SR 408	6,850	5,830	6,210	7,130	7,780	8,550	8,810	9,330	6,270	8,270	9,210
Northbound On-Ramp from WB SR 408	3,410	3,590	3,870	4,250	4,770	4,960	4,790	4,590	3,700	4,070	4,230
Southbound Off-Ramp to EB SR 408	3,480	3,430	3,740	4,000	4,590	4,400	5,060	4,680	3,610	3,900	4,050
Northbound On-Ramp from EB SR 408	15,090	15,450	16,160	17,540	18,470	18,730	18,780	18,200	14,830	16,400	18,360
Southbound Off-Ramp to WB SR 408	15,290	15,590	15,980	17,030	18,080	18,450	18,840	19,000	14,360	17,400	19,490
Exit 34 : SR 50 (East Colonial Drive)											
Northbound Off-Ramp	4,110	3,840	4,170	4,810	5,120	4,980	5,560	5,840	4,090	4,570	4,970
Southbound On-Ramp	3,550	3,480	3,730	4,250	4,600	4,810	5,010	5,000	3,900	4,230	4,610
Northbound On-Ramp	2,870	2,670	2,950	3,300	3,520	3,650	3,860	3,630	3,230	3,360	3,280
Southbound Off-Ramp	2,820	2,640	2,980	3,290	3,470	3,530	3,690	3,440	3,060	3,180	3,380

Notes:

1. 24 hour machine counts were used for SR 417 NB Off-Ramp to Florida's Turnpike and SR 417 SB Off-Ramp to Florida's Turnpike in 2017.
2. Exit 17A, South Access Road opened in 2016.
3. In May 2016, Florida's Turnpike southbound off-ramp to northbound Florida's Turnpike and SR 417 northbound off-ramps to Florida's Turnpike opened.
4. SR 417 under construction in the Years 2018-2021 from SR 50 to the Orange/Seminole County Line.
5. 2018-2022 AAWT volumes based on adopted seasonal factors, utilizing the 2016 and 2017 toll plaza transaction data.
6. SR 417 under construction from International Drive to SR 528 in the years 2021-2022.
7. SR 417 NB on-ramp from SB Florida's Turnpike and SR 417 SB on-ramp from NB/SB Florida's Turnpike opened in 2021.



Interchange - Ramp Volume Summary SR 417 (CENTRAL FLORIDA GREENEWAY)

Existing and Historical Annual Average Weekday Ramp Terminal Traffic Volumes

Ramp Location	Year 2012	Year 2013	Year 2014	Year 2015	Year 2016	Year 2017	Year 2018	Year 2019	Year 2020	Year 2021	Year 2022
Exit 37 : University Boulevard											
Northbound Off-Ramp to EB University Blvd	8,280	7,550	9,560	9,920	10,270	10,110	10,150	9,230	8,430	9,350	11,690
Northbound Off Ramp to WB University Blvd	2,020	1,780	2,060	2,200	2,440	2,470	2,770	2,680	2,180	2,710	3,170
Northbound E-PASS Ramp to University Blvd Exit	-----	-----	-----	-----	-----	9,740	9,480	7,960	6,180	7,680	9,860
Southbound On-Ramp from EB University Blvd	1,970	2,130	2,390	2,800	3,840	3,150	3,470	3,670	2,990	3,270	3,820
Southbound On Ramp from WB University Blvd	8,570	8,270	8,710	9,240	9,900	9,760	10,330	9,740	6,060	6,860	8,570
Northbound On-Ramp	3,410	3,300	3,430	3,710	3,990	4,130	4,320	4,180	3,070	3,420	3,670
Southbound Off-Ramp	3,410	3,300	3,430	3,710	3,990	3,850	4,040	3,710	2,960	3,330	3,870

Notes:

1. 24 hour machine counts were used for SR 417 NB Off-Ramp to Florida's Turnpike and SR 417 SB Off-Ramp to Florida's Turnpike in 2017.
2. Exit 17A, South Access Road opened in 2016.
3. In May 2016, Florida's Turnpike southbound off-ramp to northbound Florida's Turnpike and SR 417 northbound off-ramps to Florida's Turnpike opened.
4. SR 417 under construction in the Years 2018-2021 from SR 50 to the Orange/Seminole County Line.
5. 2018-2022 AAWT volumes based on adopted seasonal factors, utilizing the 2016 and 2017 toll plaza transaction data.
6. SR 417 under construction from International Drive to SR 528 in the years 2021-2022.
7. SR 417 NB on-ramp from SB Florida's Turnpike and SR 417 SB on-ramp from NB/SB Florida's Turnpike opened in 2021.



Western Beltway and Wekiva Parkway



2022 Traffic Data and Statistics Manual
CENTRAL FLORIDA EXPRESSWAY AUTHORITY

Existing and Historical Annual Average Weekday Mainline Traffic Volumes

Location	Year 2012	Year 2013	Year 2014	Year 2015	Year 2016	Year 2017	Year 2018	Year 2019	Year 2020	Year 2021	Year 2022
Seidel Road to Schofield Road	14,880	15,600	17,510	22,950	26,790	31,920	35,610	38,440	28,340	34,310	39,860
Schofield Road to New Independence Parkway	-----	-----	-----	23,580	27,760	34,580	39,670	44,020	33,640	40,090	47,320
New Independence Parkway to CR 535	15,930	16,620	19,520	26,200	31,570	40,570	47,440	52,650	42,710	49,110	57,490
CR 535 to Florida's Turnpike / SR 50	35,740	37,630	41,940	50,770	58,240	65,550	72,040	72,690	60,140	68,190	76,750
Florida's Turnpike / SR 50 to SR 438	40,260	43,480	48,290	57,450	65,850	73,100	78,850	81,930	74,680	77,330	81,150
SR 438 / Plant Street / Franklin Street to West Road	35,840	38,760	43,860	52,620	60,860	67,530	73,420	76,580	69,430	72,010	74,680
West Road to Ocoee Apopka Road (CR 437A)	31,650	34,430	38,930	46,360	53,510	58,710	65,900	66,280	59,680	61,870	64,550
Ocoee Apopka Road (CR 437A) to SR 414	29,320	33,220	37,440	44,190	50,580	55,370	60,200	62,270	55,290	57,240	59,840
SR 429 / 414 (SR 414 to West US 441)	-----	18,670	21,320	24,470	28,490	29,910	35,510	37,740	34,730	37,100	40,980
West US 441 to Kelly Park Road (Wekiva Parkway)	-----	-----	-----	-----	-----	8,930	15,600	18,900	18,530	21,210	23,760
Kelly Park Road to SR 453	-----	-----	-----	-----	-----	-----	11,880	13,850	14,180	18,560	20,290
SR 453 to Orange/Lake County Line	-----	-----	-----	-----	-----	-----	5,440	5,850	4,690	5,910	8,930

Notes:

- The SR 429/414 Extension opened to traffic in January 2013. At the same time, the existing north portion of SR 429 from SR 414 to US 441 was re-named SR 451.
- CR 437A Northbound On and Southbound Off ramps opened to traffic in January 2013.
- Wekiva Parkway from SR 429 Connector Road to Kelly Park Road opened in July 2017.
- Wekiva Parkway, from Kelly Park Road to SR 46 including the SR 453 interchange, opened in April 2018.
- 2018 - 2022 AAWDT volumes based on adopted seasonal factors, utilizing the 2016 and 2017 toll facility transaction data.
- SR 429 under construction in the Years 2021-2022 from CR 535 to SR 414.



Mainline Volume Summary

SR 429 (WESTERN BELTWAY AND WEKIVA PARKWAY)

SECTION II

28

Existing and Historical Annual Average Weekday Ramp Terminal Traffic Volumes

Ramp Location	Year 2012	Year 2013	Year 2014	Year 2015	Year 2016	Year 2017	Year 2018	Year 2019	Year 2020	Year 2021	Year 2022
Exit 13 : Schofield Road											
Northbound Off-Ramp	-----	-----	-----	-----	290	430	490	510	440	420	470
Southbound On-Ramp	-----	-----	-----	-----	190	220	260	300	320	320	360
Northbound On-Ramp from WB Schofield Road	-----	-----	-----	-----	820	1,890	2,530	3,120	3,050	3,200	4,130
Northbound On-Ramp from EB Schofield Road	-----	-----	-----	-----	95	220	290	360	300	320	140
Southbound Off-Ramp	-----	-----	-----	-----	680	1,510	2,150	2,940	2,610	2,970	3,540
Exit 15 : New Independence Parkway											
Northbound Off-Ramp	370	530	780	980	1,020	1,290	1,580	1,910	1,480	1,640	1,970
Southbound On-Ramp	400	490	790	1,030	1,110	1,420	1,640	1,960	1,260	1,570	1,890
Northbound On-Ramp	920	1,180	1,880	2,410	3,000	4,550	5,680	6,400	5,810	5,920	7,250
Southbound Off-Ramp	900	1,140	1,790	2,290	2,820	4,190	5,370	6,050	5,910	6,300	7,030
Exit 18 : Stoneybrook West Parkway											
Northbound On-Ramp	-----	-----	-----	-----	-----	-----	-----	-----	3,650	4,480	4,930
Southbound Off-Ramp	-----	-----	-----	-----	-----	-----	-----	-----	2,890	3,550	5,140
Exit 19 : CR 535											
Northbound Off-Ramp	1,790	1,740	2,000	2,520	2,990	3,410	3,890	4,210	3,190	4,060	4,950
Southbound On-Ramp	1,650	1,750	1,910	2,370	2,750	3,400	3,900	4,240	3,670	4,380	5,090
Northbound On-Ramp	11,710	12,030	12,820	14,090	15,720	15,350	17,050	13,240	6,440	8,820	8,930
Southbound Off-Ramp	11,540	12,060	12,810	14,170	15,790	15,630	16,140	15,130	9,550	10,780	11,080
Exits 22 & 23 : Florida's Turnpike / SR 50											
Northbound On-Ramp from SR 50	2,750	2,750	2,970	3,480	3,800	3,460	4,210	4,440	3,990	4,370	4,960
Southbound Off-Ramp to SR 50	2,690	2,810	3,170	3,500	3,650	3,970	4,310	4,570	4,090	4,310	4,510
Northbound Off-Ramp to NB Turnpike	1,530	1,840	1,850	2,680	2,890	3,530	3,900	4,040	2,550	3,510	4,020
Northbound Off-Ramp to SB Turnpike	8,450	9,040	9,900	11,900	13,430	14,730	15,960	16,700	10,560	14,520	16,270
Southbound On-Ramp from NB Turnpike	7,920	7,830	8,530	10,110	12,010	12,880	14,870	14,850	11,620	14,130	14,780
Southbound On-Ramp from SB Turnpike	1,920	2,190	2,310	3,150	3,200	3,900	4,530	4,690	3,670	4,460	4,810

Notes:

- The SR 429/414 Extension opened to traffic in January 2013. At the same time, the existing north portion of SR 429 from SR 414 to US 441 was re-named SR 451.
- CR 437A Northbound On and Southbound Off ramps opened to traffic in January 2013.
- Wekiva Parkway from SR 429 Connector Road to Kelly Park Road opened in July 2017.
- Wekiva Parkway, from Kelly Park Road to SR 46 including the SR 453 interchange, opened in April 2018.
- 2018 - 2022 AAWDT volumes based on adopted seasonal factors, utilizing the 2016 and 2017 toll facility transaction data.
- SR 429 under construction in the Years 2021-2022 from CR 535 to SR 414.



Interchange - Ramp Volume Summary SR 429 (WESTERN BELTWAY AND WEKIVA PARKWAY)

Existing and Historical Annual Average Weekday Ramp Terminal Traffic Volumes

Ramp Location	Year 2012	Year 2013	Year 2014	Year 2015	Year 2016	Year 2017	Year 2018	Year 2019	Year 2020	Year 2021	Year 2022
Northbound Off-Ramp to SR 50	1,990	1,780	1,900	2,450	2,400	2,380	2,920	3,660	3,010	3,450	3,710
Southbound On-Ramp from SR 50	2,170	2,750	2,100	2,680	2,580	2,440	2,960	3,380	2,890	3,470	3,940
Northbound On-Ramp from NB Turnpike	9,200	9,630	10,410	12,060	14,240	15,820	16,090	16,550	14,750	15,010	15,480
Northbound On-Ramp from SB Turnpike	3,190	3,280	3,680	4,640	5,440	5,350	6,040	6,450	5,750	6,460	7,040
Southbound Off-Ramp to NB Turnpike	3,140	3,130	3,390	4,160	4,770	5,270	6,100	6,150	6,350	6,780	6,630
Southbound Off-Ramp to SB Turnpike	9,270	7,910	8,530	10,120	11,160	12,190	12,770	12,930	13,350	14,260	14,780
Exit 24 : SR 438 / Plant Street											
Northbound Off-Ramp	3,640	3,810	4,150	4,710	5,450	5,650	6,100	5,920	5,650	6,020	7,220
Southbound On-Ramp	3,280	3,550	3,750	4,280	4,740	5,000	5,310	5,180	4,700	5,160	6,010
Northbound On-Ramp	1,110	1,470	1,640	2,000	2,170	2,340	2,720	2,720	2,450	2,630	3,110
Southbound Off-Ramp	1,390	1,500	1,680	1,900	2,040	2,610	2,620	2,780	2,570	2,820	3,080
Exit 26 : West Road											
Northbound Off-Ramp	2,590	2,740	3,260	3,860	4,760	5,410	6,110	6,580	6,000	6,500	6,890
Southbound On-Ramp	2,730	2,790	3,270	3,870	4,690	5,380	6,010	6,340	5,960	6,540	6,930
Northbound On-Ramp	530	620	800	810	950	1,020	1,350	1,360	1,270	1,430	1,440
Southbound Off-Ramp	600	570	720	730	840	1,010	1,330	1,310	1,220	1,360	1,370
Exit 29 : CR 437A (Ocoee Apopka Road)											
Northbound Off-Ramp	2,590	2,740	3,260	3,860	4,760	5,410	6,110	6,580	6,000	3,440	3,630
Southbound On-Ramp	2,730	2,790	3,270	3,870	4,690	5,380	6,010	6,340	5,960	3,460	3,650
Northbound On-Ramp	530	620	800	810	950	1,020	1,350	1,360	1,270	1,170	1,300
Southbound Off-Ramp	600	570	720	730	840	1,010	1,330	1,310	1,220	1,070	1,250

Notes:

1. The SR 429/414 Extension opened to traffic in January 2013. At the same time, the existing north portion of SR 429 from SR 414 to US 441 was re-named SR 451.
2. CR 437A Northbound On and Southbound Off ramps opened to traffic in January 2013.
3. Wekiva Parkway from SR 429 Connector Road to Kelly Park Road opened in July 2017.
4. Wekiva Parkway, from Kelly Park Road to SR 46 including the SR 453 interchange, opened in April 2018.
5. 2018 - 2022 AAWDT volumes based on adopted seasonal factors, utilizing the 2016 and 2017 toll facility transaction data.
6. SR 429 under construction in the Years 2021-2022 from CR 535 to SR 414.



Interchange - Ramp Volume Summary SR 429 (WESTERN BELTWAY AND WEKIVA PARKWAY)

Existing and Historical Annual Average Weekday Ramp Terminal Traffic Volumes

Ramp Location	Year 2012	Year 2013	Year 2014	Year 2015	Year 2016	Year 2017	Year 2018	Year 2019	Year 2020	Year 2021	Year 2022
Exit 30: SR 414 (Apopka Expressway)											
Northbound Off-Ramp to SR 414 / 451	5,030	6,040	7,220	14,040	16,360	17,410	17,630	17,810	15,310	16,650	15,980
Northbound Off-Ramp to EB SR 414	5,030	6,040	7,220	8,950	10,620	10,470	12,030	11,540	10,570	10,840	10,510
Northbound Off-Ramp to NB SR 451	-----	-----	-----	5,090	5,740	6,940	5,600	6,270	4,740	5,810	5,470
Southbound On-Ramp from WB SR 414	4,960	5,700	6,920	8,130	9,990	9,640	11,960	12,410	10,030	10,770	10,780
Southbound On-Ramp from SB 451	-----	-----	-----	6,190	6,500	4,290	5,970	6,020	5,070	5,950	5,060
Northbound On-Ramp from WB SR 414	-----	3,050	3,410	3,950	4,700	4,290	5,610	5,660	5,040	5,680	6,470
Southbound Off-Ramp to EB SR 414	-----	3,080	3,510	3,990	4,630	4,210	5,370	5,740	5,260	5,830	6,610
Exit 34: SR 429 Connector Road (US 441/CR 437)											
Northbound Off-Ramp	-----	9,330	10,950	12,420	14,310	10,260	7,770	10,060	8,590	8,740	9,150
Southbound On-Ramp	-----	7,050	7,410	7,240	8,340	12,870	14,140	9,810	8,070	8,210	8,600
Northbound On-Ramp	-----	-----	-----	-----	-----	170	470	520	430	490	530
Southbound Off-Ramp	-----	-----	-----	-----	-----	300	520	500	480	560	590
Exit 38: Kelly Park Road											
Northbound Off-Ramp	-----	-----	-----	-----	-----	4,720	2,900	3,360	2,600	2,960	3,470
Southbound On-Ramp	-----	-----	-----	-----	-----	4,210	3,090	3,470	2,790	3,140	3,670
Northbound On-Ramp	-----	-----	-----	-----	-----	-----	380	430	330	450	430
Northbound Loop On-Ramp	-----	-----	-----	-----	-----	-----	310	360	280	390	760
Southbound Off-Ramp	-----	-----	-----	-----	-----	-----	620	880	600	850	1,190
Exit 39: SR 453											
Northbound Off-Ramp	-----	-----	-----	-----	-----	-----	3,310	3,920	4,860	6,080	7,040
Southbound On-Ramp	-----	-----	-----	-----	-----	-----	2,280	3,940	5,350	6,590	7,630
Northbound On-Ramp	-----	-----	-----	-----	-----	-----	70	120	100	470	1,400
Southbound Off-Ramp	-----	-----	-----	-----	-----	-----	100	80	70	410	1,070

Notes:

- The SR 429/414 Extension opened to traffic in January 2013. At the same time, the existing north portion of SR 429 from SR 414 to US 441 was re-named SR 451.
- CR 437A Northbound On and Southbound Off ramps opened to traffic in January 2013.
- Wekiva Parkway from SR 429 Connector Road to Kelly Park Road opened in July 2017.
- Wekiva Parkway, from Kelly Park Road to SR 46 including the SR 453 interchange, opened in April 2018.
- 2018 - 2022 AAWDT volumes based on adopted seasonal factors, utilizing the 2016 and 2017 toll facility transaction data.
- SR 429 under construction in the Years 2021-2022 from CR 535 to SR 414.



Apopka Expressway



Existing and Historical Annual Average Weekday Mainline Traffic Volumes

Location	Year 2012	Year 2013	Year 2014	Year 2015	Year 2016	Year 2017	Year 2018	Year 2019	Year 2020	Year 2021	Year 2022
SR 451 / SR 429 to Marden Road	16,320	20,870	24,120	29,100	33,900	36,790	39,660	40,290	34,620	36,920	38,700
Marden Road to Keene Road	-----	-----	-----	-----	-----	36,500	41,930	42,840	37,360	40,070	42,840
Keene Road to Hiwassee Road	20,590	24,670	28,290	33,500	38,600	41,870	46,210	48,090	41,640	44,780	47,850
Hiwassee Road to US 441 (Orange Blossom Trail)	21,990	25,900	28,810	34,200	38,700	41,110	44,870	45,940	40,450	43,170	45,690
US 441 (Orange Blossom Trail) to Rose Avenue / Bear Lake Road	34,040	35,290	37,790	42,400	44,300	45,080	45,700	45,020	44,720	47,350	51,220

Notes:

1. The SR 429 / 414 Extension, which extended SR 414 to the west of SR 451, opened to traffic in January 2013.
2. In June 2017, the Marden Road interchange opened to traffic.
3. 2018-2022 AAWT volumes based on adopted seasonal factors, utilizing the 2016 and 2017 toll plaza transaction data.
4. 2018-2019 AAWT volumes were adjusted for the eastbound on ramp from Orange Blossom Trail.

Existing and Historical Annual Average Weekday Ramp Terminal Traffic Volumes

Ramp Location	Year 2012	Year 2013	Year 2014	Year 2015	Year 2016	Year 2017	Year 2018	Year 2019	Year 2020	Year 2021	Year 2022
Exit 4B : SR 429 (Western Beltway)											
Eastbound On-Ramp from NB SR 429	5,030	6,040	7,220	8,950	10,620	10,470	12,250	11,540	10,570	10,840	10,510
Westbound Off-Ramp to SB SR 429	4,960	5,700	6,920	8,130	9,990	9,640	12,170	12,410	10,030	10,770	10,780
Eastbound On-Ramp from SB SR 429 / 414	-----	3,080	3,510	3,990	4,630	4,210	5,470	5,740	5,260	5,830	5,060
Westbound Off-Ramp to NB SR 429 / 414	-----	3,050	3,410	3,950	4,700	4,290	5,710	5,660	5,040	5,680	6,470
Exit 4A : SR 451											
Eastbound On-Ramp from SR 451 SB	3,710	1,600	1,310	1,550	1,600	2,410	2,420	2,270	2,140	2,400	2,700
Westbound Off-Ramp to SR 451 NB	3,030	1,410	1,550	1,730	1,960	2,000	2,040	1,930	1,660	1,840	2,260
Eastbound Off-Ramp to SR 451 NB	-----	-----	-----	5,090	5,740	6,970	5,700	5,770	4,740	5,810	5,470
Westbound On Ramp from SR 451 SB	-----	-----	-----	6,190	6,500	7,760	6,130	6,020	5,070	5,950	5,060
Exit 5 : Marden Road											
Eastbound On-Ramp	-----	-----	-----	-----	-----	680	980	1,280	1,500	1,650	2,390
Westbound Off-Ramp	-----	-----	-----	-----	-----	580	910	1,150	1,370	1,500	2,170
Exit 6 : Keene Road											
Eastbound On-Ramp	2,220	2,100	2,090	2,260	2,400	2,620	2,350	2,710	2,140	2,360	2,520
Westbound Off-Ramp	2,050	1,920	1,967	2,140	2,290	2,550	2,340	2,190	2,090	2,210	2,470
Exit 8 : Hiawasse Road											
Eastbound Off-Ramp	1,550	1,600	1,840	2,280	2,550	2,810	3,370	3,170	2,890	3,090	3,500
Westbound On-Ramp	1,430	1,600	1,970	2,430	2,790	2,780	3,020	3,090	2,900	3,170	3,590
Eastbound On-Ramp	2,220	2,210	2,250	2,530	2,490	2,460	2,490	2,300	2,300	2,390	2,460
Westbound Off-Ramp	2,160	2,210	2,450	2,630	2,620	2,490	2,540	2,410	2,280	2,310	2,300

Notes:

1. The SR 429 / 414 Extension, which extended SR 414 to the west of SR 451, opened to traffic in January 2013.
2. In June 2017, the Marden Road interchange opened to traffic.
3. 2018-2022 AAWT volumes based on adopted seasonal factors, utilizing the 2016 and 2017 toll plaza transaction data.
4. 2018-2019 AAWT volumes were adjusted for the eastbound on ramp from Orange Blossom Trail.



Interchange - Ramp Volume Summary SR 414 (APOPKA EXPRESSWAY)

Existing and Historical Annual Average Weekday Ramp Terminal Traffic Volumes

Ramp Location	Year 2012	Year 2013	Year 2014	Year 2015	Year 2016	Year 2017	Year 2018	Year 2019	Year 2020	Year 2021	Year 2022
Exit 9 : US 441 (Orange Blossom Trail)											
Eastbound Off-Ramp	1,940	2,130	2,430	2,980	3,780	4,260	5,070	5,130	3,780	4,040	4,420
Westbound On-Ramp from NB US 441	1,320	1,420	1,660	2,050	2,560	2,910	3,420	3,210	2,310	2,730	2,980
Westbound On-Ramp from SB US 441	280	390	390	430	550	610	730	720	580	580	640
Eastbound On-Ramp	6,940	5,870	5,660	5,770	5,270	5,020	5,390	5,130	4,220	4,630	5,320
Westbound Off-Ramp	8,650	7,600	7,720	7,900	7,280	6,770	7,270	6,920	6,900	7,180	8,240

Notes:

1. The SR 429 / 414 Extension, which extended SR 414 to the west of SR 451, opened to traffic in January 2013.
2. In June 2017, the Marden Road interchange opened to traffic.
3. 2018-2022 AAWT volumes based on adopted seasonal factors, utilizing the 2016 and 2017 toll plaza transaction data.
4. 2018-2019 AAWT volumes were adjusted for the eastbound on ramp from Orange Blossom Trail.



Western Beltway Connector Road



Existing and Historical Annual Average Weekday Mainline Traffic Volumes

Location	Year 2012	Year 2013	Year 2014	Year 2015	Year 2016	Year 2017	Year 2018	Year 2019	Year 2020	Year 2021	Year 2022
SR 429 / SR 451 to US 441 (Orange Blossom Trail)	26,070	12,250	12,820	14,560	15,800	17,300	17,690	15,980	13,610	16,000	13,090

Notes:

1. SR 429 / 414 interchange was under construction during the Years 2011-2012.
2. The SR 429 / 414 Extension opened to traffic in January 2013. The existing portion of SR 429 from SR 414 to US 441 was re-named SR 451.
3. Wekiva Phase II opened to traffic April 1, 2018.
4. 2018-2022 AAWT volumes based on adopted seasonal factors, utilizing the 2016 and 2017 toll plaza transaction data.



Mainline Volume Summary

SR 451 (WESTERN BELTWAY CONNECTOR ROAD)

Existing and Historical Annual Average Weekday Ramp Terminal Traffic Volumes

Ramp Location	Year 2012	Year 2013	Year 2014	Year 2015	Year 2016	Year 2017	Year 2018	Year 2019	Year 2020	Year 2021	Year 2022
Exit 4A: SR 414 East / SR 429 South											
Northbound On-Ramp from NB SR 429	9,415	4,130	4,570	5,090	5,740	6,910	6,220	5,500	4,740	5,810	5,470
Southbound Off-Ramp to SB SR 429	10,120	5,090	5,330	6,190	6,500	7,680	6,620	5,740	5,070	5,950	5,060
Northbound On-Ramp from WB SR 414	2,825	1,410	1,550	1,730	1,960	2,000	2,220	1,840	1,660	1,840	2,260
Southbound Off-Ramp to EB SR 414	3,710	1,600	1,310	1,550	1,600	1,870	2,630	2,160	2,140	2,400	2,700
Expressway Ends : US 441 (OBT) and Vick Road											
Northbound Off-Ramp	12,240	5,660	5,960	6,820	7,700	8,890	8,980	7,340	6,400	6,860	7,730
Southbound On-Ramp from SB US 441	9,960	2,760	2,660	2,840	2,930	3,170	2,810	2,550	2,460	2,720	2,750
Southbound On-Ramp from NB US 441 / Vick Road	3,870	3,840	4,260	4,900	5,170	6,400	5,900	5,360	5,090	4,960	5,020

Notes:

1. SR 429 / 414 interchange was under construction during the Years 2011-2012.
2. The SR 429 / 414 Extension opened to traffic in January 2013. The existing portion of SR 429 from SR 414 to US 441 was re-named SR 451.
3. Wekiva Phase II opened to traffic April 1, 2018.
4. 2018-2022 AAWT volumes based on adopted seasonal factors, utilizing the 2016 and 2017 toll plaza transaction data.



Interchange - Ramp Volume Summary SR 451 (WESTERN BELTWAY CONNECTOR ROAD)

SR 453



Existing and Historical Annual Average Weekday Mainline Traffic Volumes

Location	Year 2012	Year 2013	Year 2014	Year 2015	Year 2016	Year 2017	Year 2018	Year 2019	Year 2020	Year 2021	Year 2022
SR 429 to SR 46	-----	-----	-----	-----	-----	-----	5,460	8,630	10,390	13,550	17,140

Notes:

1. SR 453 opened in March 2018.
2. 2018 - 2022 AAWT volumes based on adopted seasonal factors, utilizing the 2016 and 2017 toll facility transaction data.

Existing and Historical Annual Average Weekday Ramp Terminal Traffic Volumes

Ramp Location	Year 2012	Year 2013	Year 2014	Year 2015	Year 2016	Year 2017	Year 2018	Year 2019	Year 2020	Year 2021	Year 2022
Exit To and From SR 429											
Northbound On-Ramp from NB SR 429	-----	-----	-----	-----	-----	-----	3,140	3,920	4,860	6,080	7,040
Southbound Off-Ramp to SB SR 429	-----	-----	-----	-----	-----	-----	2,160	3,940	5,350	6,590	7,630
Northbound On-Ramp from SB 429	-----	-----	-----	-----	-----	-----	90	80	70	470	1,400
Northbound On-Ramp from SB 429	-----	-----	-----	-----	-----	-----	70	120	100	410	1,070
Expressway Ends : SR 46											
Northbound Off-Ramp	-----	-----	-----	-----	-----	-----	3,230	4,620	5,330	7,040	8,440
Southbound On-Ramp	-----	-----	-----	-----	-----	-----	2,230	4,700	5,880	7,600	8,700

Notes:

1. SR 453 opened in March 2018.
2. 2018 - 2022 AAWT volumes based on adopted seasonal factors, utilizing the 2016 and 2017 toll facility transaction data.



Poinciana Parkway



Existing and Historical Annual Average Weekday Mainline Traffic Volumes

Location	Year 2012	Year 2013	Year 2014	Year 2015	Year 2016	Year 2017	Year 2018	Year 2019	Year 2020	Year 2021	Year 2022
Cypress Parkway to Koa Street	-----	-----	-----	-----	2,560	2,880	3,240	3,650	3,970	4,090	4,640
Koa Street to Marigold Avenue	-----	-----	-----	-----	1,660	2,500	3,690	4,560	5,330	6,660	7,560
Marigold Avenue to Osceola / Polk County Line	-----	-----	-----	-----	7,110	8,060	9,890	10,740	10,940	13,060	14,830

Notes:

1. Poinciana Parkway (SR 538) was incorporated into the CFX System in December 2019.
2. Poinciana Parkway (SR 538) opened to traffic in 2016. Data for 2016 represents December AWT.
3. SR 538 under construction in the Years 2021-2022 for widening from Cypress Parkway to Ronald Reagan Parkway.



Mainline Volume Summary SR 538 (POINCIANA PARKWAY)

Existing and Historical Annual Average Weekday Ramp Terminal Traffic Volumes

Ramp Location	Year 2012	Year 2013	Year 2014	Year 2015	Year 2016	Year 2017	Year 2018	Year 2019	Year 2020	Year 2021	Year 2022
Marigold Avenue											
Northbound On-Ramp	-----	-----	-----	-----	-----	-----	-----	3,210	2,910	3,310	3,770
Southbound Off-Ramp	-----	-----	-----	-----	-----	-----	-----	2,990	2,700	3,080	3,490
Koa Street											
Northbound On-Ramp	-----	-----	-----	-----	-----	-----	-----	560	770	680	1,650
Southbound Off-Ramp	-----	-----	-----	-----	-----	-----	-----	510	590	990	1,270

Notes:

1. Poinciana Parkway (SR 538) was incorporated into the CFX System in December 2019.
2. Poinciana Parkway (SR 538) opened to traffic in 2016. Data for 2016 represents December AWT.
3. SR 538 under construction in the Years 2021-2022 for widening from Cypress Parkway to Ronald Reagan Parkway.



Systemwide Adjustment Factors

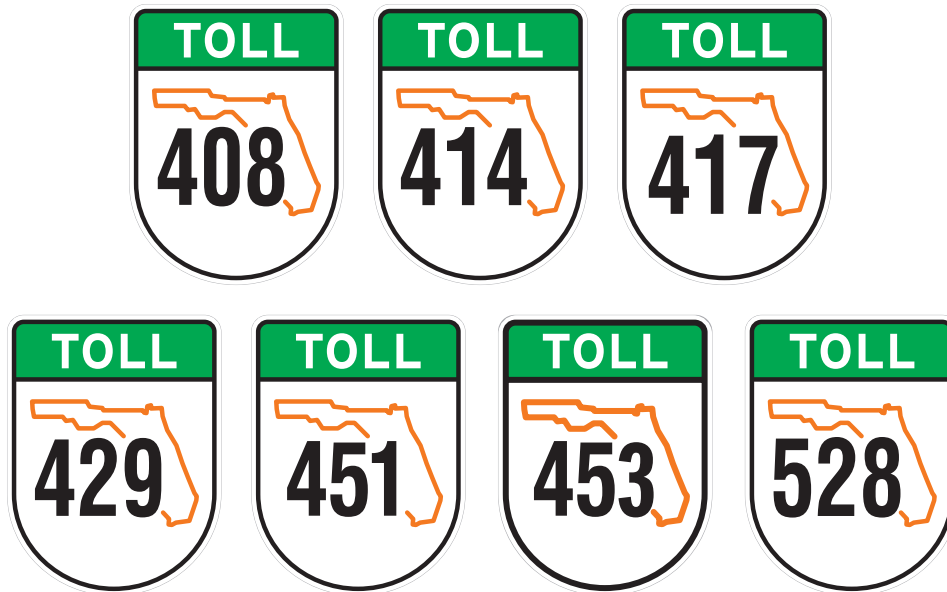

Weekday, Daily and Monthly Adjustment Factors

Annual Average Weekday Traffic (AAWT) is the estimated volume of traffic on a highway and/or expressway segment for five (5) days of the week (Monday through Friday). This is obtained from collecting 24-hour, 72-hour and/or monthly traffic counts and adjusting these weekday traffic counts by utilizing calculated daily and monthly seasonal adjustment factors.

All weekday traffic volumes collected must be adjusted to reflect the seasonal changes in traffic volumes. In order to calculate the AAWT and Annual Average Daily Traffic (AADT), monthly seasonal adjustment factors are calculated from transactions for each of the mainline toll facility for each month of the year. These factors are then used to convert the 24-hour Weekday Traffic Counts to AAWT.

In addition to developing the AAWT, seasonal adjustment factors and an AADT conversion factor was determined. AADT is the estimated daily traffic volume on a highway and/or expressway for all days of the week (Monday through Sunday) over the period of one year. The AADT is obtained by taking similar adjustment factors developed from the mainline and ramp toll facility transactions and applying those factors to the same 24-hour weekday traffic counts. This calculated factor is used to convert the AAWT to AADT by multiplying the appropriate factor by the corresponding AAWT to obtain the AADT volume.

The following tables summarize the daily and monthly adjustment factors for the Central Florida Expressway Authority's system. Note that these adjustment factors are based on adopted seasonal factors, utilizing the 2016 and 2017 toll facility transaction data.

Annual Average Weekday Traffic (AAWT)

Monthly Seasonal Conversion Factors

CFX Expressway System	AAWT Monthly Conversion Factors					
	January	February	March	April	May	June
SR 408 (East-West Expressway)						
Florida's Turnpike (SR 91) to Interstate 4 (I-4)	1.0382	1.0374	0.9863	0.9807	0.9903	1.0464
Interstate 4 (I-4) to SR 50 (East Colonial Drive)	1.0178	1.0196	0.9891	0.9802	0.9760	1.0528
SR 528 (Beachline Expressway)						
Boggy Creek Road to SR 417 (Central Florida GreeneWay)	0.9907	1.0030	1.0065	0.9922	0.9902	0.9940
SR 417 (Central Florida GreeneWay) to SR 520	1.0793	1.0720	0.9332	0.9832	0.9932	0.9966
SR 417 (Central Florida GreeneWay)						
International Drive to SR 528 (Beachline Expressway)	1.1184	1.0876	0.9763	0.9860	1.0017	1.0266
SR 528 (Beachline Expressway) to Orange/Seminole County Line	1.0690	1.0617	0.9992	0.9912	0.9549	1.0686
SR 429 (Western Beltway and Wekiva Parkway)						
Seidel Road to CR 535 (Winter Garden Vineland Road)	1.0976	1.1017	0.9838	1.0032	1.0230	1.0131
CR 535 (Winter Garden Vineland Road) to US 441 (Orange Blossom Trail)	1.0667	1.0653	0.9996	0.9994	1.0002	1.0109
SR 414 (Apopka Expressway)						
SR 429 to US 441 (Orange Blossom Trail)	0.9346	1.0814	1.0212	1.0171	1.0208	1.0361
SR 451 (Western Beltway Connector Road)						
SR 429 to US 441 (Orange Blossom Trail)	1.0006	1.0734	1.0104	1.0083	1.0105	1.0235
SR 453						
SR 429 to SR 46	1.0391	0.9694	1.0715	0.9466	0.9670	0.9453

CFX Expressway System	AAWT Monthly Conversion Factor					
	July	August	September	October	November	December
SR 408 (East-West Expressway)						
Florida's Turnpike (SR 91) to Interstate 4 (I-4)	1.0257	1.0128	0.9806	0.9642	0.9723	0.9766
Interstate 4 (I-4) to SR 50 (East Colonial Drive)	1.0487	1.0206	1.0026	0.9529	0.9701	0.9873
SR 528 (Beachline Expressway)						
Boggy Creek Road to SR 417 (Central Florida GreeneWay)	0.9825	1.0101	1.0281	1.0193	1.0001	0.9906
SR 417 (Central Florida GreeneWay) to SR 520	0.9583	1.0080	1.0413	1.0148	0.9881	0.9599
SR 417 (Central Florida GreeneWay)						
International Drive to SR 528 (Beachline Expressway)	0.9822	1.0117	1.0174	0.9646	0.9531	0.9149
SR 528 (Beachline Expressway) to Orange/Seminole County Line	1.0287	1.0117	0.9783	0.9517	0.9524	0.9634
SR 429 (Western Beltway and Wekiva Parkway)						
Seidel Road to CR 535 (Winter Garden Vineland Road)	0.9780	1.0081	0.9977	0.9710	0.9581	0.9014
CR 535 (Winter Garden Vineland Road) to US 441 (Orange Blossom Trail)	1.0324	1.0006	0.9849	0.9589	0.9613	0.9402
SR 414 (Apopka Expressway)						
SR 429 to US 441 (Orange Blossom Trail)	1.0248	1.0124	0.9938	0.9651	0.9708	0.9551
SR 451 (Western Beltway Connector Road)						
SR 429 to US 441 (Orange Blossom Trail)	1.0286	1.0066	0.9894	0.9620	0.9661	0.9476
SR 453						
SR 429 to SR 46	0.9831	0.9629	0.9961	1.1253	0.9744	1.0245

Notes:

1. SR 453 opened to traffic in March of 2018. Due to not having a full year's worth of traffic counts, the seasonal factors for SR 453 will match the north end of SR 429.
2. SR 538 was not included as there is not daily data available. Use 1.00 as it primarily serves as a commuter road and is low volume.
3. Plaza volumes based on 2016-2017 toll transaction data.



Annual Average Daily Traffic (AADT)

Monthly Seasonal Conversion Factors

CFX Expressway System	AADT Monthly Conversion Factors					
	January	February	March	April	May	June
SR 408 (East-West Expressway)						
Florida's Turnpike (SR 91) to Interstate 4 (I-4)	1.0461	1.0399	0.9705	0.9674	1.0045	1.0503
Interstate 4 (I-4) to SR 50 (East Colonial Drive)	1.0250	1.0252	0.9811	0.9700	0.9868	1.0597
SR 528 (Beachline Expressway)						
Boggy Creek Road to SR 417 (Central Florida GreeneWay)	0.9881	1.0028	1.0018	0.9888	1.0004	0.9886
SR 417 (Central Florida GreeneWay) to SR 520	1.0907	1.0709	0.9191	0.9669	0.9728	0.9929
SR 417 (Central Florida GreeneWay)						
International Drive to SR 528 (Beachline Expressway)	1.1376	1.0871	0.9644	0.9778	0.9985	1.0242
SR 528 (Beachline Expressway) to Orange/Seminole County Line	1.0836	1.0627	0.9809	0.9748	0.9660	1.0794
SR 429 (Western Beltway and Wekiva Parkway)						
Seidel Road to CR 535 (Winter Garden Vineland Road)	1.1185	1.0991	0.9610	0.9904	1.0212	1.0064
CR 535 (Winter Garden Vineland Road) to US 441 (Orange Blossom Trail)	1.0734	1.0636	0.9872	0.9880	1.0054	1.0072
SR 414 (Apopka Expressway)						
SR 429 to US 441 (Orange Blossom Trail)	0.9490	1.0732	1.0081	1.0018	1.0316	1.0312
SR 451 (Western Beltway Connector Road)						
SR 429 to US 441 (Orange Blossom Trail)	1.0112	1.0684	0.9976	0.9949	1.0185	1.0192
SR 453						
SR 429 to SR 46	1.1384	1.0542	1.0620	1.0305	1.0621	1.0355

CFX Expressway System	AADT Monthly Conversion Factor					
	July	August	September	October	November	December
SR 408 (East-West Expressway)						
Florida's Turnpike (SR 91) to Interstate 4 (I-4)	1.0267	1.0182	0.9880	0.9500	0.9787	0.9783
Interstate 4 (I-4) to SR 50 (East Colonial Drive)	1.0338	1.0230	1.0035	0.9420	0.9808	0.9907
SR 528 (Beachline Expressway)						
Boggy Creek Road to SR 417 (Central Florida GreeneWay)	0.9822	1.0106	1.0243	1.0170	1.0055	0.9978
SR 417 (Central Florida GreeneWay) to SR 520	0.9631	1.0179	1.0469	1.0167	0.9979	0.9743
SR 417 (Central Florida GreeneWay)						
International Drive to SR 528 (Beachline Expressway)	0.9843	1.0177	1.0244	0.9568	0.9581	0.9146
SR 528 (Beachline Expressway) to Orange/Seminole County Line	1.0223	1.0113	0.9837	0.9401	0.9624	0.9624
SR 429 (Western Beltway and Wekiva Parkway)						
Seidel Road to CR 535 (Winter Garden Vineland Road)	0.9819	1.0225	1.0098	0.9614	0.9621	0.9079
CR 535 (Winter Garden Vineland Road) to US 441 (Orange Blossom Trail)	1.0316	1.0100	0.9944	0.9496	0.9681	0.9440
SR 414 (Apopka Expressway)						
SR 429 to US 441 (Orange Blossom Trail)	1.0172	1.0230	1.0055	0.9568	0.9815	0.9575
SR 451 (Western Beltway Connector Road)						
SR 429 to US 441 (Orange Blossom Trail)	1.0244	1.0165	0.9999	0.9532	0.9748	0.9508
SR 453						
SR 429 to SR 46	1.0738	1.0556	1.0943	1.1355	0.9663	1.1055

Notes:

1. SR 453 opened to traffic in March of 2018. Due to not having a full year's worth of traffic counts, the seasonal factors for SR 453 will match the north end of SR 429.
2. SR 538 was not included as there is not daily data available. Use 1.00 as it primarily serves as a commuter road and is low volume.
3. Plaza volumes based on 2016-2017 toll transaction data.



Annual Average Weekday Traffic (AAWT) to Annual Average Daily Traffic (AADT)

Monthly Seasonal Conversion Factors

CFX Expressway System	AAWT to AADT Monthly Conversion Factors					
	January	February	March	April	May	June
SR 408 (East-West Expressway)						
Florida's Turnpike (SR 91) to Interstate 4 (I-4)	0.9637	0.9448	0.9531	0.9506	0.9621	0.9362
Interstate 4 (I-4) to SR 50 (East Colonial Drive)	0.9653	0.9470	0.9552	0.9513	0.9601	0.9417
SR 528 (Beachline Expressway)						
Boggy Creek Road to SR 417 (Central Florida GreeneWay)	1.0017	1.0044	0.9996	1.0012	1.0150	0.9992
SR 417 (Central Florida GreeneWay) to SR 520	0.9959	0.9927	0.9989	0.9949	0.9979	0.9913
SR 417 (Central Florida GreeneWay)						
International Drive to SR 528 (Beachline Expressway)	0.9774	0.9746	0.9845	0.9811	0.9840	0.9790
SR 528 (Beachline Expressway) to Orange/Seminole County Line	0.9578	0.9444	0.9513	0.9476	0.9558	0.9288
SR 429 (Western Beltway and Wekiva Parkway)						
Seidel Road to CR 535 (Winter Garden Vineland Road)	0.9664	0.9577	0.9742	0.9704	0.9811	0.9654
CR 535 (Winter Garden Vineland Road) to US 441 (Orange Blossom Trail)	0.9640	0.9414	0.9523	0.9499	0.9655	0.9440
SR 414 (Apopka Expressway)						
SR 429 to US 441 (Orange Blossom Trail)	0.9573	0.9351	0.9375	0.9337	0.9521	0.9293
SR 451 (Western Beltway Connector Road)						
SR 429 to US 441 (Orange Blossom Trail)	0.9607	0.9382	0.9449	0.9418	0.9588	0.9367
SR 453						
SR 429 to SR 46	0.9128	0.9195	1.0090	0.9185	0.9105	0.9129

CFX Expressway System	AAWT to AADT Monthly Conversion Factors					
	July	August	September	October	November	December
SR 408 (East-West Expressway)						
Florida's Turnpike (SR 91) to Interstate 4 (I-4)	0.9496	0.9580	0.9551	0.9539	0.9735	0.9623
Interstate 4 (I-4) to SR 50 (East Colonial Drive)	0.9708	0.9606	0.9621	0.9551	0.9749	0.9674
SR 528 (Beachline Expressway)						
Boggy Creek Road to SR 417 (Central Florida GreeneWay)	1.0044	1.0050	1.0007	1.0024	1.0103	1.0122
SR 417 (Central Florida GreeneWay) to SR 520	0.9996	0.9980	0.9937	0.9921	1.0040	0.9911
SR 417 (Central Florida GreeneWay)						
International Drive to SR 528 (Beachline Expressway)	0.9835	0.9886	0.9861	0.9878	0.9986	0.9853
SR 528 (Beachline Expressway) to Orange/Seminole County Line	0.9551	0.9578	0.9528	0.9535	0.9710	0.9589
SR 429 (Western Beltway and Wekiva Parkway)						
Seidel Road to CR 535 (Winter Garden Vineland Road)	0.9712	0.9736	0.9696	0.9749	0.9870	0.9739
CR 535 (Winter Garden Vineland Road) to US 441 (Orange Blossom Trail)	0.9573	0.9593	0.9526	0.9546	0.9711	0.9587
SR 414 (Apopka Expressway)						
SR 429 to US 441 (Orange Blossom Trail)	0.9503	0.9448	0.9385	0.9400	0.9586	0.9440
SR 451 (Western Beltway Connector Road)						
SR 429 to US 441 (Orange Blossom Trail)	0.9538	0.9520	0.9456	0.9473	0.9648	0.9513
SR 453						
SR 429 to SR 46	0.9156	0.9122	0.9103	0.9911	0.9194	0.9268

Notes:

1. SR 453 opened to traffic in March of 2018. Due to not having a full year's worth of traffic counts, the seasonal factors for SR 453 will match the north end of SR 429.
2. SR 538 was not included as there is not daily data available. Use 1.00 as it primarily serves as a commuter road and is low volume.
3. Plaza volumes based on 2016-2017 toll transaction data.



SECTION III: Mainline Toll Facility Characteristics



Mainline Toll Facility Characteristics

The following pages provide figures summarizing the type and number of lanes, as well as the average annual weekday traffic through the mainline toll facilities located on:

- **SR 408 (East-West Expressway)**
 - Hiawassee Mainline Toll Facility
 - Pine Hills Mainline Toll Facility
 - Conway West Mainline Toll Facility
 - Conway East Mainline Toll Facility
 - Dean Mainline Toll Facility
- **SR 528 (Beachline Expressway)**
 - Beachline Mainline Toll Facility
 - Dallas Mainline Toll Facility
- **SR 417 (Central Florida GreeneWay)**
 - John Young Mainline Toll Facility
 - Boggy Creek Mainline Toll Facility
 - Curry Ford Mainline Toll Facility
 - University Mainline Toll Facility
- **SR 429 (Western Beltway and Wekiva Parkway)**
 - Forest Lake Mainline Toll Facility
 - Independence Mainline Toll Facility
 - Ponkan Gantry Toll Facility
 - Mt. Plymouth Gantry Toll Facility
- **SR 414 (Apopka Expressway)**
 - Coral Hills Mainline Toll Facility
- **SR 453**
 - Coronado Toll Gantry Facility
- **SR 538 (Poinciana Parkway)**
 - Marigold Toll Gantry Facility
 - Koa Toll Gantry Facility
- **Non-System Goldenrod Extension**
 - Goldenrod Mainline Toll Facility

Mainline Toll Facilities (East-West Expressway)





Approx. Scale: 1" = 200'
Aerial Date: 2021

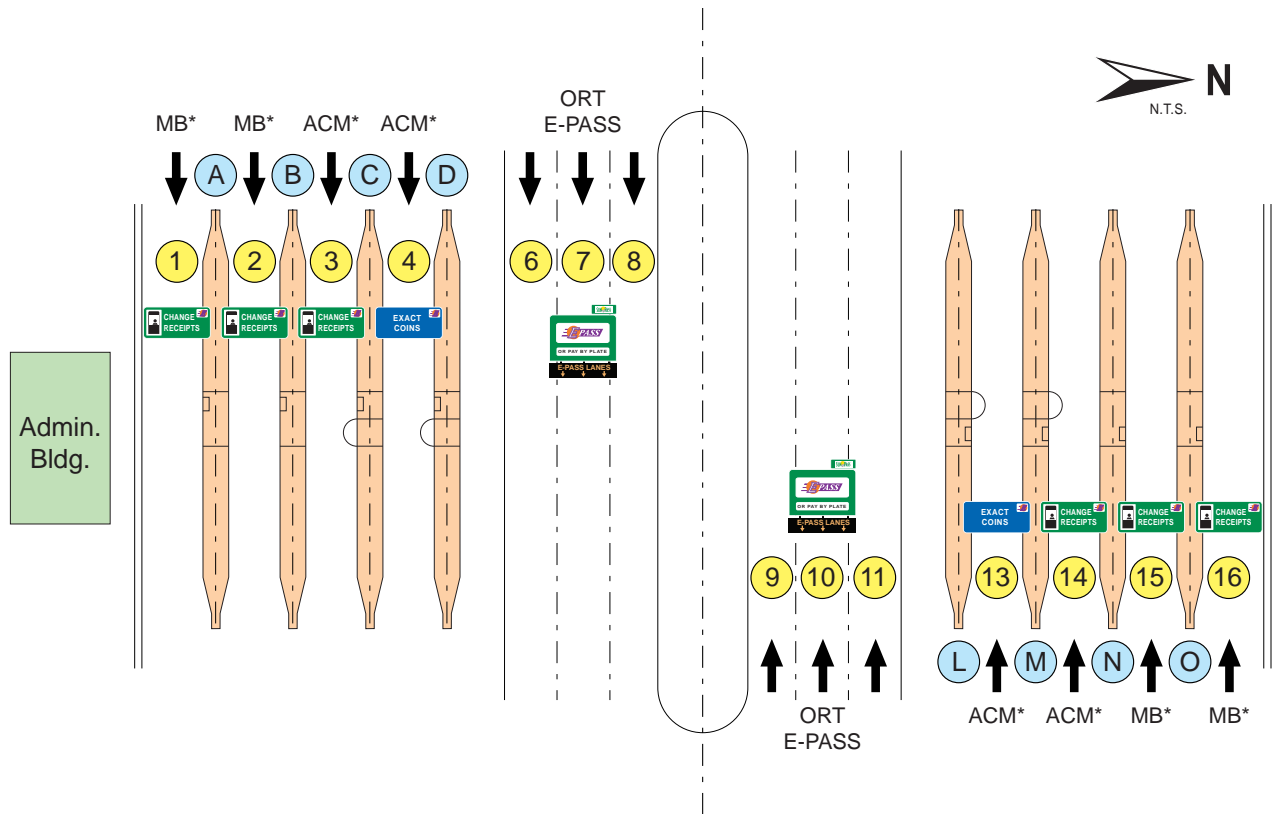

HISTORIC TRAFFIC - A.A.W.T.

1992	11,620 (Post Toll)	2003	53,070	2014	61,440
1993	13,570	2004	59,370	2015	69,490
1994	16,650	2005	59,700	2016	73,510
1995	18,460	2006	64,200	2017	72,200
1996	23,250	2007	66,820	2018	84,520 (Toll Increase July 2018)
1997	25,830	2008	61,620	2019	86,170
1998	31,400	2009	59,900 (Toll Increase April 2009)	2020	69,530
1999	34,370	2010	56,680	2021	79,090
2000	41,040	2011	57,170	2022	91,240
2001	45,180	2012	56,330 (Toll Increase July 2012)		
2002	49,490	2013	57,750		

TOLL RATE STRUCTURE

	<u>E-PASS</u>	<u>CASH</u>	<u>PAY-BY-PLATE</u>
2 Axles	\$.93	\$ 1.25	\$ 1.86
3 Axles	\$ 1.89	\$ 2.25	\$ 3.78
4 Axles	\$ 2.18	\$ 2.50	\$ 4.36
5 Axles or more	\$ 2.82	\$ 3.25	\$ 5.64

(Toll Rates Effective July 1, 2023)

Note: In 2017, CFX instituted the Customer First Toll Policy.

LANES OF EQUIPMENT

- 4 Manned Booths (MB) with E-PASS
- 2 Booths with Automatic Coin Machines (ACM) and E-PASS
- 6 Open Road Tolling (ORT) E-PASS
- * Changeable Message Sign

LEGEND

- ① Lane Number
- Ⓐ Island Designation



Approx. Scale: 1" = 200'
Aerial Date: 2021

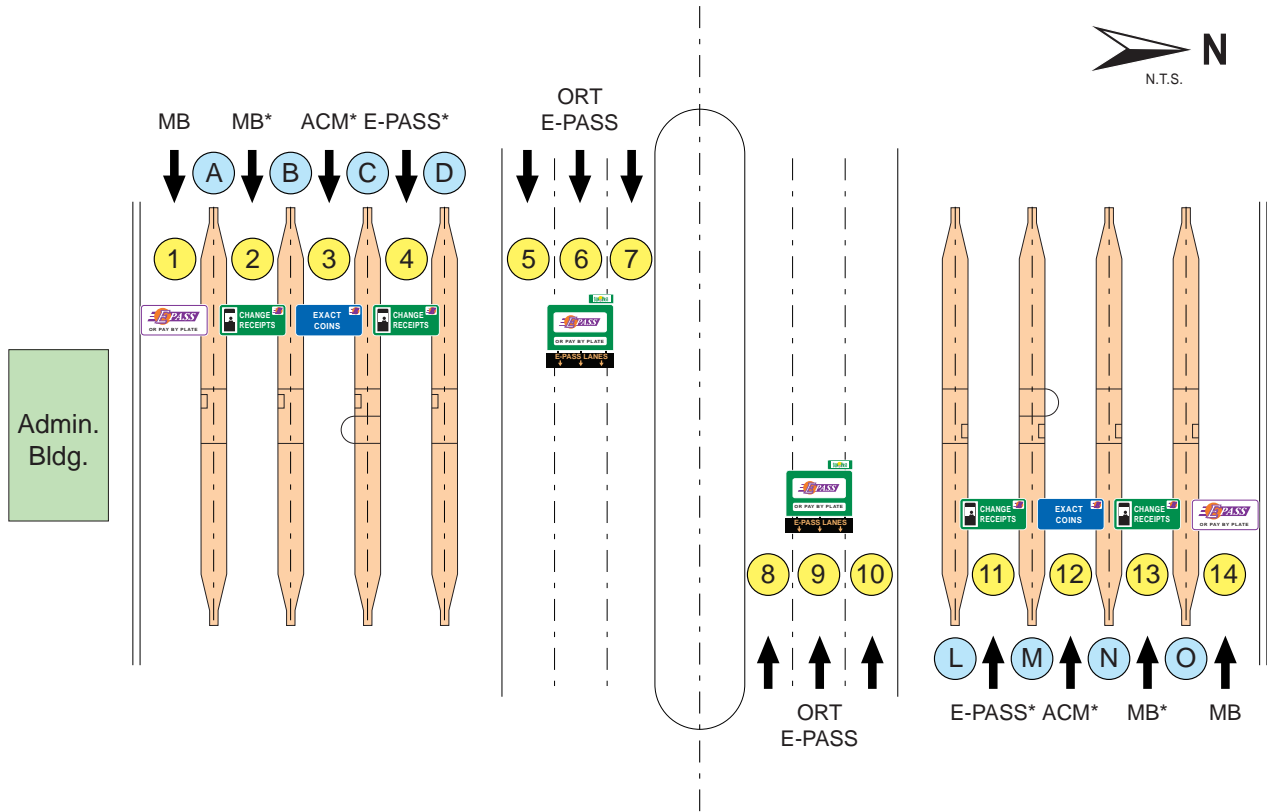

HISTORIC TRAFFIC - A.A.W.T.

2006	78,660	2012	71,190 (Toll Increase July 2012)	2018	100,740 (Toll Increase July 2018)
2007	82,710	2013	72,020	2019	99,470
2008	77,800	2014	77,210	2020	80,290
2009	69,800 (Toll Increase April 2009)	2015	85,210	2021	92,470
2010	71,150	2016	89,080	2022	105,140
2011	72,070	2017	94,910		

TOLL RATE STRUCTURE

	<u>E-PASS</u>	<u>CASH</u>	<u>PAY-BY-PLATE</u>
2 Axles	\$ 1.25	\$ 1.50	\$ 2.50
3 Axles	\$ 1.89	\$ 2.25	\$ 3.78
4 Axles	\$ 2.18	\$ 2.50	\$ 4.36
5 Axles or more	\$ 2.82	\$ 3.25	\$ 5.64

(Toll Rates Effective July 1, 2023)

Note: In 2017, CFX instituted the Customer First Toll Policy.

LANES OF EQUIPMENT

- 4 Manned Booths (MB) with E-PASS
- 2 Booths with Automatic Coin Machines (ACM) and E-PASS
- 2 Booths with Dedicated E-PASS
- 6 Open Road Tolling (ORT) E-PASS
- * Changeable Message Sign

LEGEND

- ① Lane Number
- Ⓐ Island Designation



Pine Hills Mainline Toll Facility
SR 408 (EAST-WEST EXPRESSWAY)



Approx. Scale: 1" = 300'
Aerial Date: 2021

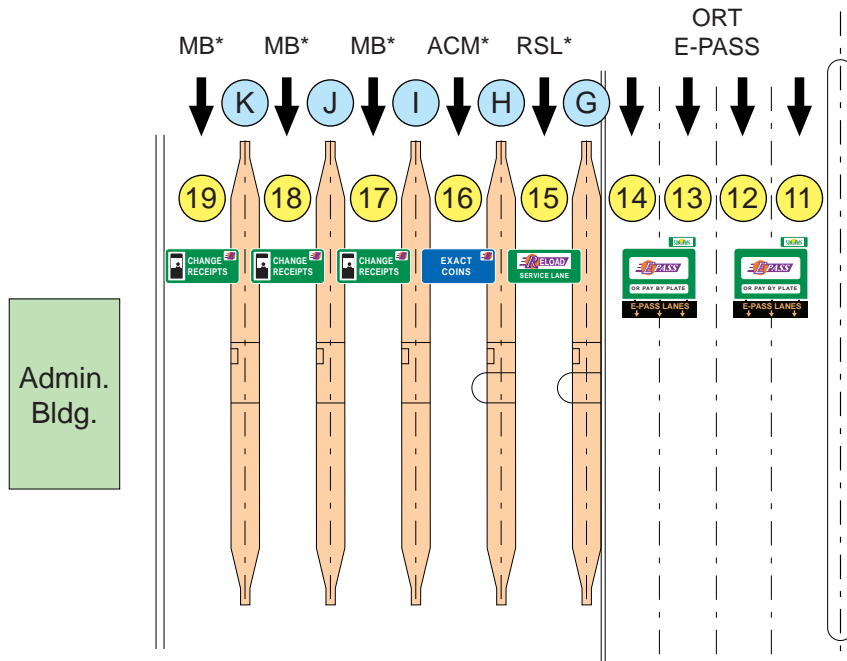

** Historic traffic includes both the Conway East & West Mainline Toll Facilities.

HISTORIC TRAFFIC - A.A.W.T. **

1992	No Count (Post Toll)	2003	116,000	2014	122,400
1993	62,620	2004	125,460	2015	132,940
1994	64,650	2005	123,500	2016	140,380
1995	73,020	2006	125,000	2017	147,220
1996	77,400	2007	118,100	2018	151,570 (Toll Increase July 2018)
1997	87,810	2008	112,200	2019	139,400
1998	94,450	2009	112,750 (Toll Increase April 2009)	2020	128,900
1999	98,850	2010	117,830	2021	146,130
2000	105,200	2011	119,600	2022	163,360
2001	107,940	2012	117,530 (Toll Increase July 2012)		
2002	110,130	2013	115,530		

TOLL RATE STRUCTURE

	<u>E-PASS</u>	<u>CASH</u>	<u>PAY-BY-PLATE</u>
2 Axles	\$ 1.25	\$ 1.50	\$ 2.50
3 Axles	\$ 1.89	\$ 2.25	\$ 3.78
4 Axles	\$ 2.18	\$ 2.50	\$ 4.36
5 Axles or more	\$ 2.82	\$ 3.25	\$ 5.64

(Toll Rates Effective July 1, 2023)

Note: In 2017, CFX instituted the Customer First Toll Policy.

LANES OF EQUIPMENT

- 3 Manned Booths (MB) with E-PASS
- 1 Booth with Automatic Coin Machines (ACM) and E-PASS
- 1 Reload Service Lane (RSL)
- 4 Open Road Tolling (ORT) E-PASS
- * Changeable Message Sign

LEGEND

- ① Lane Number
- Ⓐ Island Designation

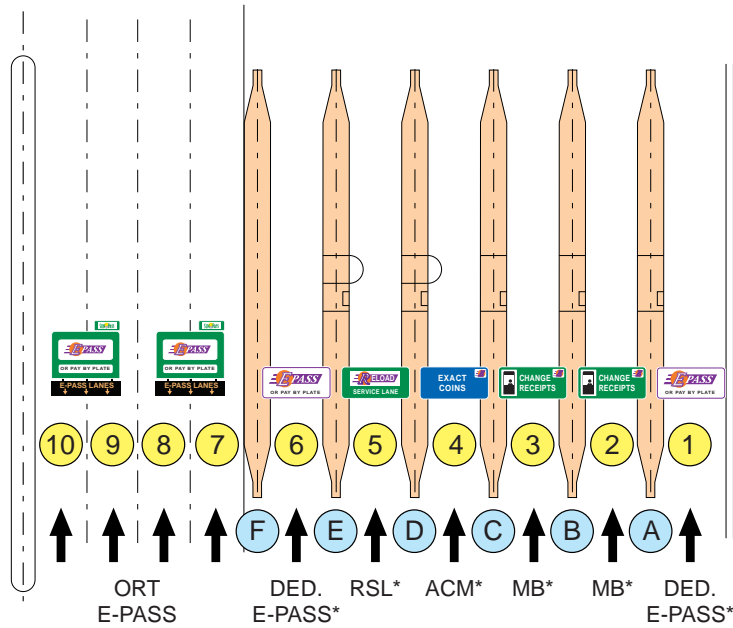

** Historic traffic includes both the Conway East & West Mainline Toll Facilities.

HISTORIC TRAFFIC - A.A.W.T. **

1992	No Count (Post Toll)	2003	116,000	2014	122,400
1993	62,620	2004	125,460	2015	132,940
1994	64,650	2005	123,500	2016	140,380
1995	73,020	2006	125,000	2017	147,220
1996	77,400	2007	118,100	2018	151,570 (Toll Increase July 2018)
1997	87,810	2008	112,200	2019	139,400
1998	94,450	2009	112,750 (Toll Increase April 2009)	2020	128,900
1999	98,850	2010	117,830	2021	146,130
2000	105,200	2011	119,600	2022	163,360
2001	107,940	2012	117,530 (Toll Increase July 2012)		
2002	110,130	2013	115,530		

TOLL RATE STRUCTURE

	E-PASS	CASH	PAY-BY-PLATE
2 Axles	\$ 1.25	\$ 1.50	\$ 2.50
3 Axles	\$ 1.89	\$ 2.25	\$ 3.78
4 Axles	\$ 2.18	\$ 2.50	\$ 4.36
5 Axles or more	\$ 2.82	\$ 3.25	\$ 5.64

(Toll Rates Effective July 1, 2023)

Note: In 2017, CFX instituted the Customer First Toll Policy.

LANES OF EQUIPMENT

- 2 Manned Booths (MB) with E-PASS
- 1 Booth with Automatic Coin Machines (ACM) and E-PASS
- 1 Reload Service Lane (RSL)
- 2 Dedicated E-PASS Lanes
- 4 Open Road Tolling (ORT) E-PASS
- * Changeable Message Sign

LEGEND

- ① Lane Number
- Ⓐ Island Designation



Approx. Scale: 1" = 200'
Aerial Date: 2021

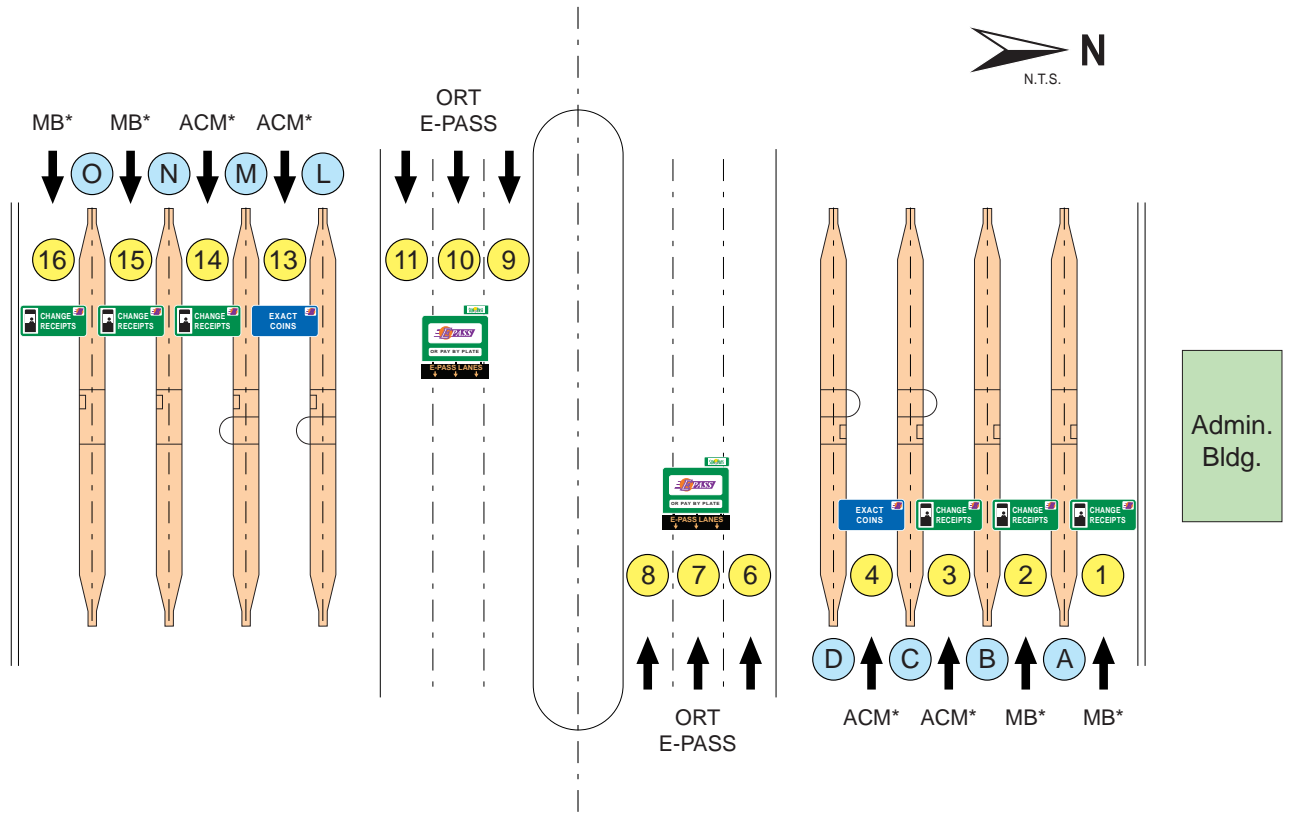

HISTORIC TRAFFIC - A.A.W.T.

1992	13,680 (Post Toll)	2003	57,600	2014	71,110
1993	14,740	2004	63,930	2015	74,180
1994	16,380	2005	65,900	2016	79,580
1995	20,410	2006	69,900	2017	83,570
1996	22,770	2007	70,100	2018	85,430 (Toll Increase July 2018)
1997	26,360	2008	66,000	2019	76,400
1998	31,630	2009	65,900 (Toll Increase April 2009)	2020	59,850
1999	38,530	2010	68,130	2021	66,590
2000	45,800	2011	66,670	2022	74,450
2001	50,100	2012	67,200 (Toll Increase July 2012)		
2002	53,760	2013	67,320		

TOLL RATE STRUCTURE

	E-PASS	CASH	PAY-BY-PLATE
2 Axles	\$.93	\$ 1.25	\$ 1.86
3 Axles	\$ 1.89	\$ 2.25	\$ 3.78
4 Axles	\$ 2.18	\$ 2.50	\$ 4.36
5 Axles or more	\$ 2.82	\$ 3.25	\$ 5.64

(Toll Rates Effective July 1, 2023)
 Note: In 2017, CFX instituted the Customer First Toll Policy.

LANES OF EQUIPMENT

- 4 Manned Booths (MB) with E-PASS
- 4 Booths with Automatic Coin Machines (ACM) and E-PASS
- 1 Reload Service Lane (RSL)
- 6 Open Road Tolling (ORT) E-PASS
- * Changeable Message Sign

LEGEND

- ① Lane Number
- Ⓐ Island Designation



Dean Mainline Toll Facility
 SR 408 (EAST-WEST EXPRESSWAY)

Mainline Toll Facilities (Beachline Expressway)





Approx. Scale: 1" = 200'
Aerial Date: 2021

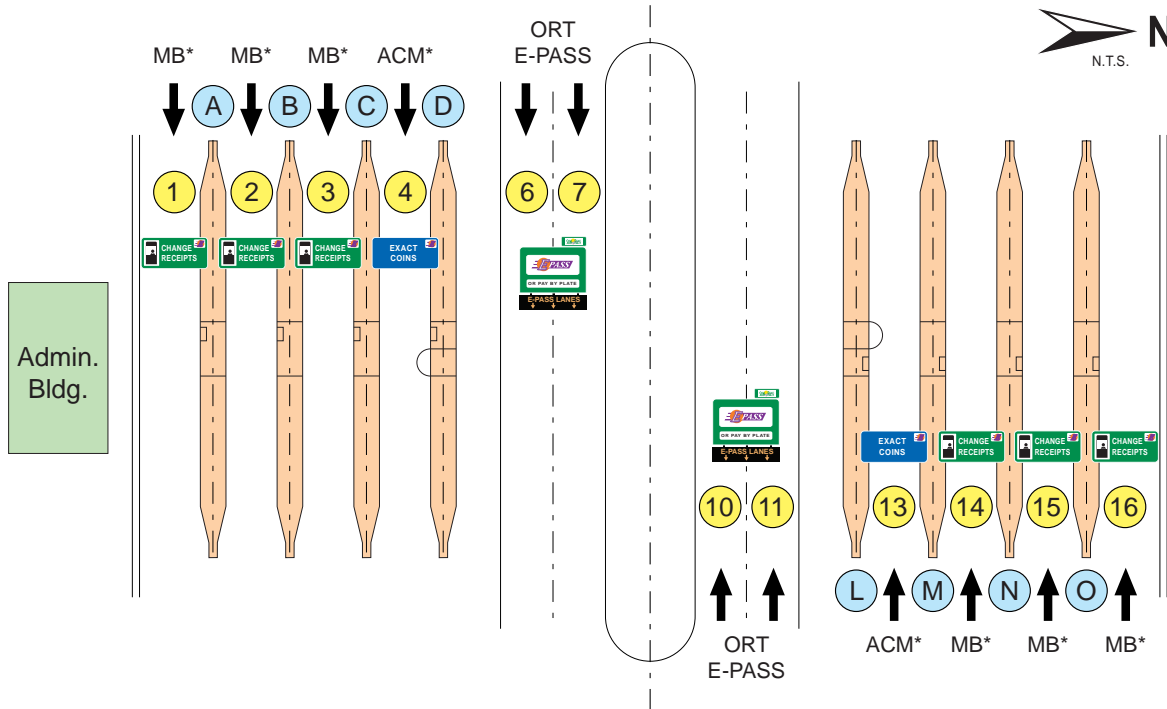

HISTORIC TRAFFIC - A.A.W.T.

1992	18,630 (Post Toll)	2003	39,940	2014	53,510
1993	21,090	2004	45,930	2015	56,120
1994	21,800	2005	46,000	2016	60,710
1995	22,130	2006	46,300	2017	65,540
1996	23,920	2007	47,700	2018	72,670 (Toll Increase July 2018)
1997	25,520	2008	42,500	2019	70,270
1998	29,420	2009	43,300 (Toll Increase April 2009)	2020	54,990
1999	29,970	2010	46,300	2021	63,240
2000	33,590	2011	46,880	2022	70,700
2001	34,590	2012	48,430 (Toll Increase July 2012)		
2002	36,760	2013	49,230		

TOLL RATE STRUCTURE

	E-PASS	CASH	PAY-BY-PLATE
2 Axles	\$.99	\$ 1.25	\$ 1.98
3 Axles	\$ 1.97	\$ 2.25	\$ 3.94
4 Axles	\$ 2.29	\$ 2.50	\$ 4.58
5 Axles or more	\$ 2.92	\$ 3.25	\$ 5.84

(Toll Rates Effective July 1, 2023)

Note: In 2017, CFX instituted the Customer First Toll Policy.

LANES OF EQUIPMENT

- 6 Manned Booths (MB) with E-PASS
- 2 Booths with Automatic Coin Machines (ACM) and E-PASS
- 4 Open Road Tolling (ORT) E-PASS
- * Changeable Message Sign
- ** \$0.25 of toll paid to FDOT for removed FDOT facility

LEGEND

- ① Lane Number
- Ⓐ Island Designation



Approx. Scale: 1" = 200'
Aerial Date: 2021

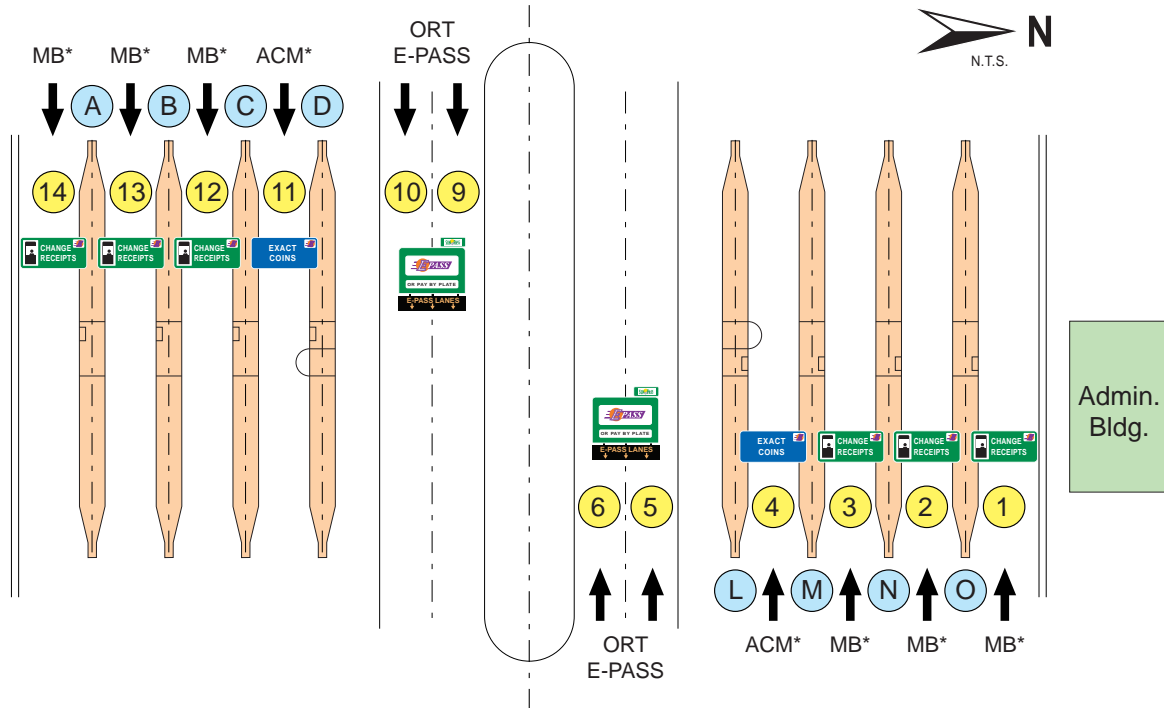

HISTORIC TRAFFIC - A.A.W.T.

2012	38,360	2016	46,880	2020	42,330
2013	39,190	2017	51,122	2021	52,180
2014	40,890	2018	57,230 <i>(Toll Increase July 2018)</i>	2022	57,630
2015	45,530	2019	55,040		

TOLL RATE STRUCTURE

	E-PASS	CASH	PAY-BY-PLATE
2 Axles	\$.84	\$ 1.50	\$ 1.91
3 Axles	\$ 1.12	\$ 1.75	\$ 2.47
4 Axles	\$ 1.41	\$ 2.00	\$ 3.05
5 Axles or more	\$ 1.41	\$ 2.00	\$ 3.05

(Toll Rates Effective July 1, 2023)

Note: In 2017, CFX instituted the Customer First Toll Policy.

Note: Toll rates shown reflect tolls collected by CFX and Florida's Turnpike Enterprise.

LANES OF EQUIPMENT

- 6 Manned Booths (MB) with E-PASS
- 2 Booths with Automatic Coin Machines (ACM) and E-PASS
- 4 Open Road Tolling (ORT) E-PASS
- * Changeable Message Sign

LEGEND

- ① Lane Number
- Ⓐ Island Designation

Mainline Toll Facilities (Central Florida GreeneWay)





Approx. Scale: 1" = 200'
Aerial Date: 2021

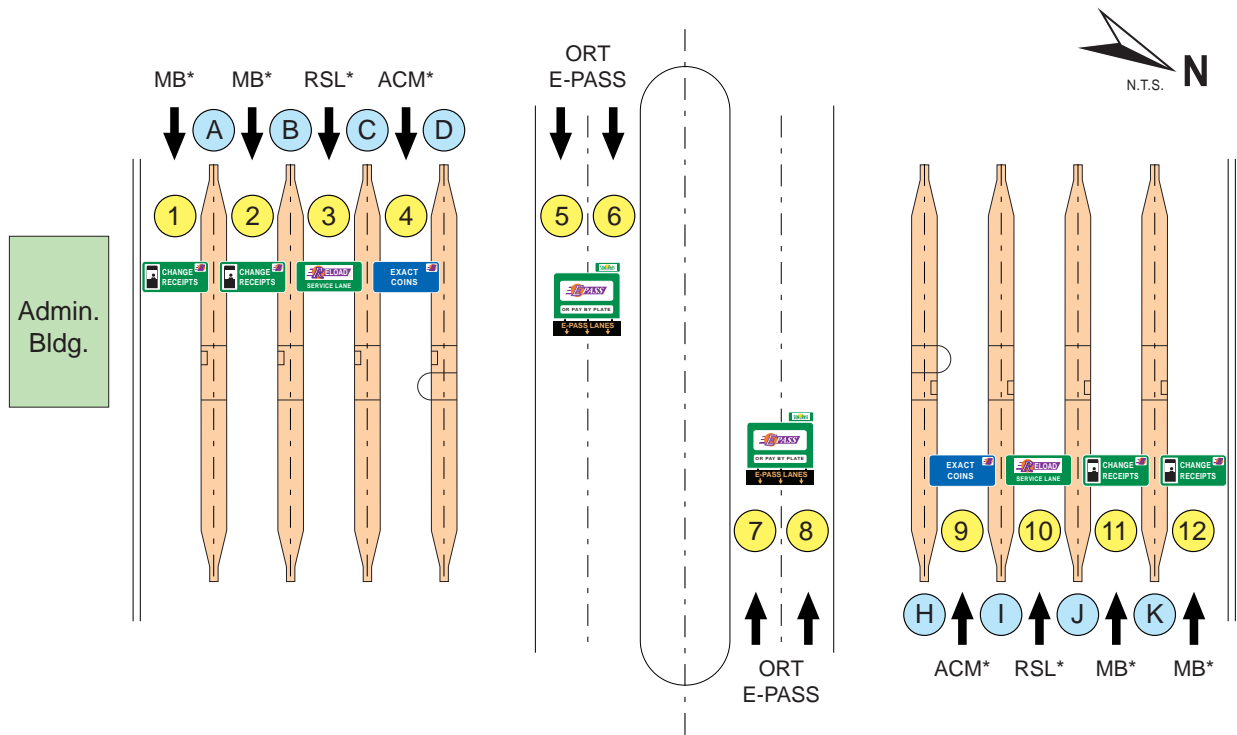

HISTORIC TRAFFIC - A.A.W.T.

1993	7,370	2003	33,240	2013	44,780
1994	11,370	2004	40,000	2014	44,780
1995	13,070	2005	40,500	2015	51,500
1996	17,520	2006	42,700	2016	62,150
1997	20,550	2007	45,800	2017	76,880
1998	22,660	2008	43,500	2018	83,600 <i>(Toll Increase July 2018)</i>
1999	25,630	2009	38,200 <i>(Toll Increase April 2009)</i>	2019	79,710
2000	28,660	2010	39,630	2020	47,650
2001	29,160	2011	41,400	2021	67,590
2002	32,020	2012	41,300 <i>(Toll Increase July 2012)</i>	2022	78,510

TOLL RATE STRUCTURE

	E-PASS	CASH	PAY-BY-PLATE
2 Axles	\$ 1.56	\$ 1.75	\$ 3.12
3 Axles	\$ 2.18	\$ 2.50	\$ 4.36
4 Axles	\$ 2.82	\$ 3.25	\$ 5.64
5 Axles or more	\$ 3.44	\$ 3.75	\$ 6.88

(Toll Rates Effective July 1, 2023)

Note: In 2017, CFX instituted the Customer First Toll Policy.

LANES OF EQUIPMENT

- 4 Manned Booths (MB) with E-PASS
- 2 Booths with Automatic Coin Machines (ACM) and E-PASS
- 2 Reload Service Lanes (RSL)
- 4 Open Road Tolling (ORT) E-PASS
- * Changeable Message Sign

LEGEND

- ① Lane Number
- Ⓐ Island Designation



Approx. Scale: 1" = 200'
Aerial Date: 2021

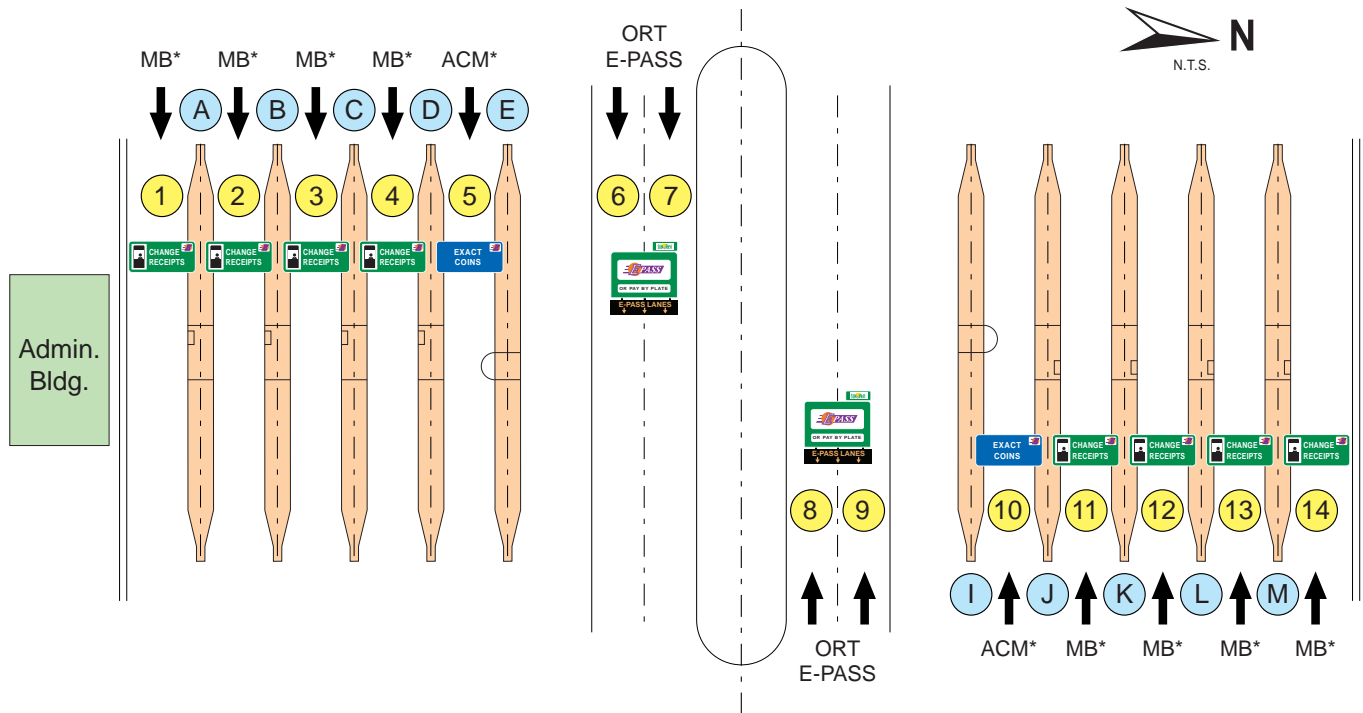

HISTORIC TRAFFIC - A.A.W.T.

1993	6,200	2003	30,190	2013	40,300
1994	10,750	2004	36,920	2014	44,880
1995	11,970	2005	37,900	2015	54,580
1996	15,780	2006	42,400	2016	66,700
1997	17,760	2007	44,800	2017	78,830
1998	20,400	2008	44,400	2018	87,570 (Toll Increase July 2018)
1999	22,440	2009	35,900 (Toll Increase April 2009)	2019	84,070
2000	24,380	2010	36,520	2020	57,680
2001	25,180	2011	38,300	2021	70,740
2002	28,120	2012	38,350 (Toll Increase July 2012)	2022	80,090

TOLL RATE STRUCTURE

	E-PASS	CASH	PAY-BY-PLATE
2 Axles	\$ 1.56	\$ 1.75	\$ 3.12
3 Axles	\$ 2.18	\$ 2.50	\$ 4.36
4 Axles	\$ 2.82	\$ 3.25	\$ 5.64
5 Axles or more	\$ 3.44	\$ 3.75	\$ 6.88

(Toll Rates Effective July 1, 2023)

Note: In 2017, CFX instituted the Customer First Toll Policy.

LANES OF EQUIPMENT

- 8 Manned Booths (MB) with E-PASS
- 2 Booths with Automatic Coin Machines (ACM) and E-PASS
- 4 Open Road Tolling (ORT) E-PASS
- * Changeable Message Sign

LEGEND

- ① Lane Number
- Ⓐ Island Designation



Approx. Scale: 1" = 200'
Aerial Date: 2021

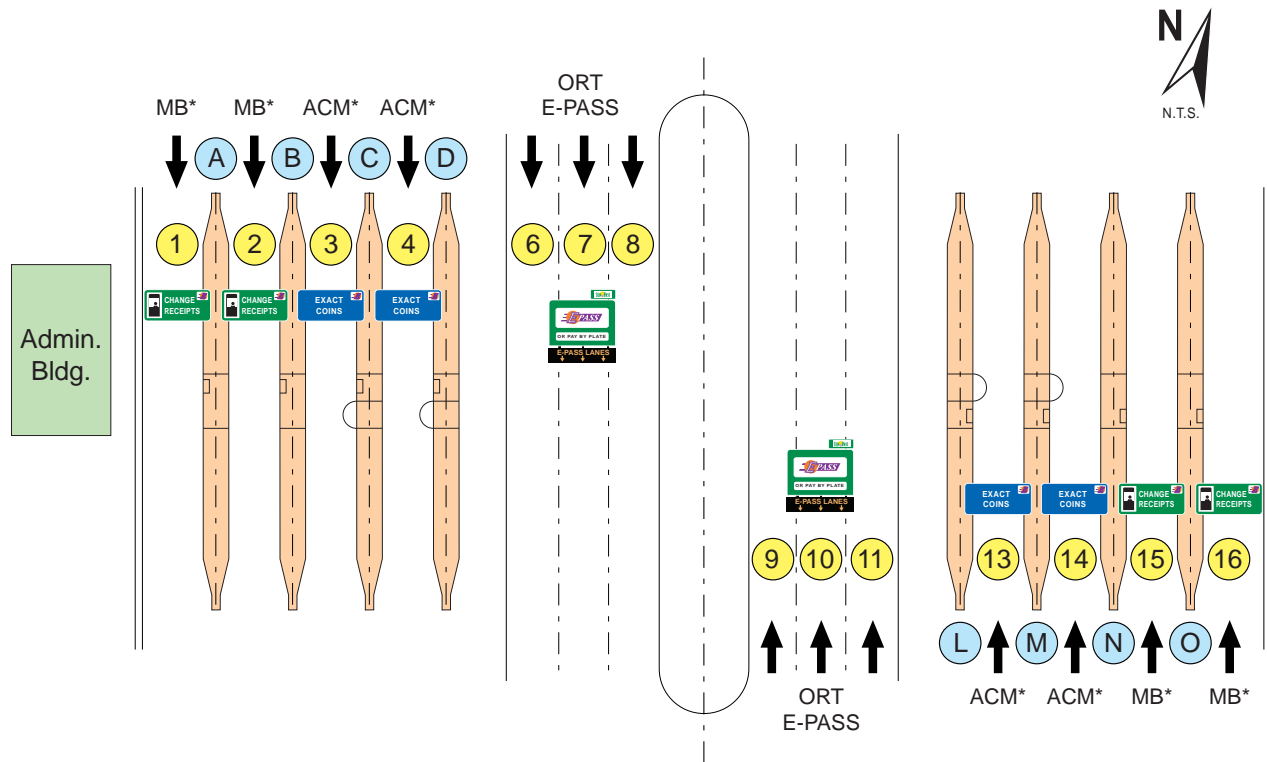

HISTORIC TRAFFIC - A.A.W.T.

1992	9,950 (Post Toll)	2003	54,760	2014	73,770
1993	13,550	2004	67,010	2015	86,030
1994	17,810	2005	69,900	2016	97,280
1995	21,810	2006	74,300	2017	105,660
1996	26,780	2007	76,100	2018	117,750 (Toll Increase July 2018)
1997	27,880	2008	68,900	2019	117,000
1998	33,530	2009	63,300 (Toll Increase April 2009)	2020	86,420
1999	39,270	2010	63,160	2021	96,810
2000	42,460	2011	62,530	2022	105,860
2001	44,290	2012	64,950 (Toll Increase July 2012)		
2002	50,200	2013	66,820		

TOLL RATE STRUCTURE

	<u>E-PASS</u>	<u>CASH</u>	<u>PAY-BY-PLATE</u>
2 Axles	\$.93	\$ 1.25	\$ 1.86
3 Axles	\$ 1.89	\$ 2.25	\$ 3.78
4 Axles	\$ 2.18	\$ 2.50	\$ 4.36
5 Axles or more	\$ 2.82	\$ 3.25	\$ 5.64

(Toll Rates Effective July 1, 2023)

Note: In 2017, CFX instituted the Customer First Toll Policy.

LANES OF EQUIPMENT

- 4 Manned Booths (MB) with E-PASS
- 4 Booths with Automatic Coin Machines (ACM) and E-PASS
- 6 Open Road Tolling (ORT) E-PASS
- * Changeable Message Sign

LEGEND

- ① Lane Number
- Ⓐ Island Designation



Approx. Scale: 1" = 200'
Aerial Date: 2021

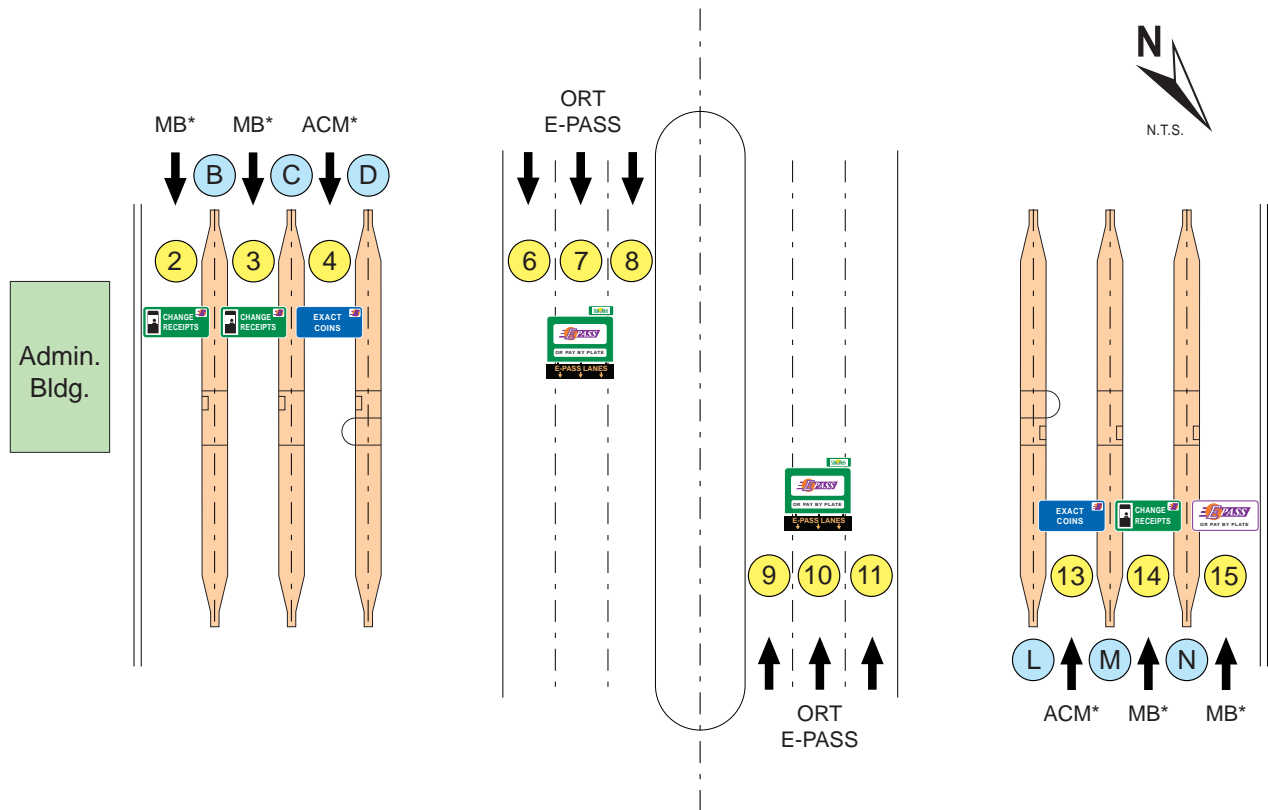

HISTORIC TRAFFIC - A.A.W.T.

1992	15,910 (Post Toll)	2003	68,590	2014	74,080
1993	19,370	2004	77,940	2015	86,650
1994	26,420	2005	79,700	2016	95,670
1995	31,500	2006	81,600	2017	103,030
1996	37,300	2007	82,800	2018	110,100 (Toll Increase July 2018)
1997	38,730	2008	75,600	2019	87,170
1998	44,610	2009	70,500 (Toll Increase April 2009)	2020	78,840
1999	49,900	2010	72,900	2021	87,450
2000	53,240	2011	74,900	2022	92,330
2001	56,370	2012	72,750 (Toll Increase July 2012)		
2002	60,650	2013	71,670		

TOLL RATE STRUCTURE

	<u>E-PASS</u>	<u>CASH</u>	<u>PAY-BY-PLATE</u>
2 Axles	\$.93	\$ 1.25	\$ 1.86
3 Axles	\$ 1.89	\$ 2.25	\$ 3.78
4 Axles	\$ 2.18	\$ 2.50	\$ 4.36
5 Axles or more	\$ 2.82	\$ 3.25	\$ 5.64

(Toll Rates Effective July 1, 2023)

Note: In 2017, CFX instituted the Customer First Toll Policy.

LANES OF EQUIPMENT

- 4 Manned Booths (MB) with E-PASS
- 4 Booths with Automatic Coin Machines (ACM) and E-PASS
- 6 Open Road Tolling (ORT) E-PASS
- * Changeable Message Sign

LEGEND

- ① Lane Number
- Ⓐ Island Designation

Mainline Toll Facilities (Western Beltway)





Approx. Scale: 1" = 200'
Aerial Date: 2021

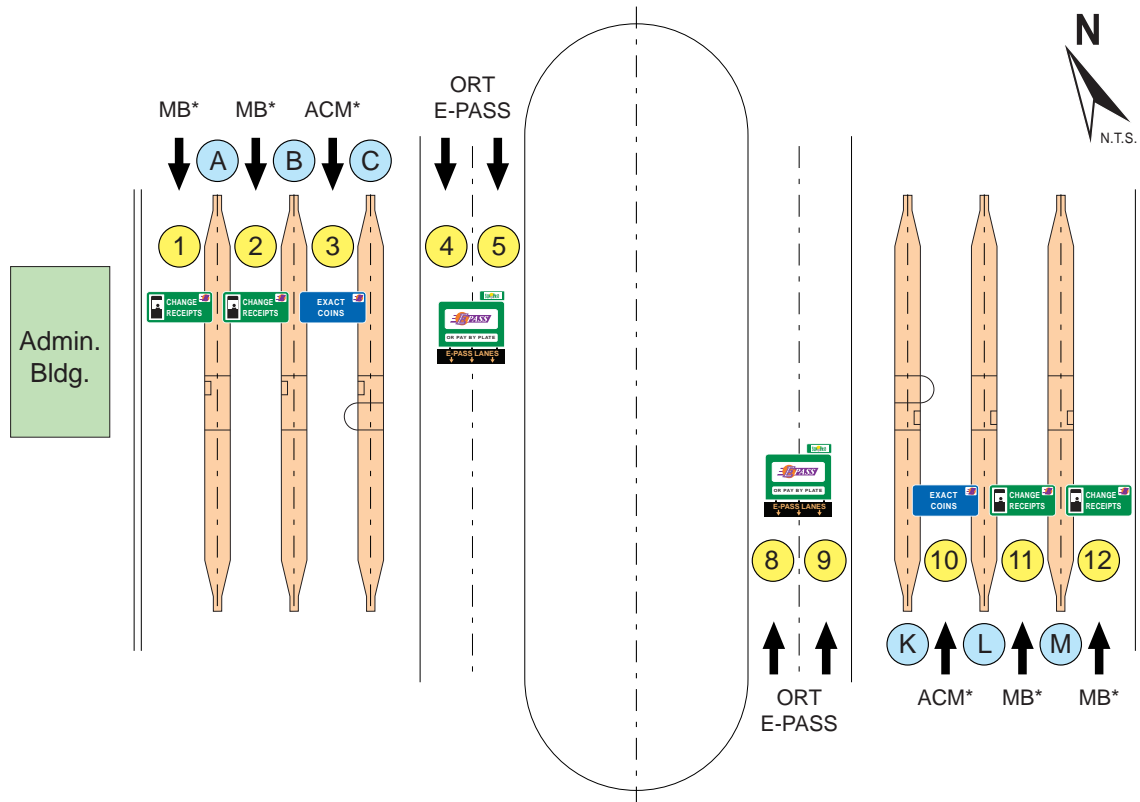

HISTORIC TRAFFIC - A.A.W.T.

2006	8,400	2012	15,930 (Toll Increase July 2012)	2018	49,150 (Toll Increase July 2018)
2007	14,000	2013	16,620	2019	52,650
2008	13,500	2014	19,520	2020	42,710
2009	12,500 (Toll Increase April 2009)	2015	26,200	2021	49,110
2010	13,700	2016	31,570	2022	57,490
2011	14,130	2017	41,260		

TOLL RATE STRUCTURE

	E-PASS	CASH	PAY-BY-PLATE
2 Axles	\$ 1.56	\$ 1.75	\$ 3.12
3 Axles	\$ 2.18	\$ 2.50	\$ 4.36
4 Axles	\$ 2.82	\$ 3.25	\$ 5.64
5 Axles or more	\$ 3.44	\$ 4.00	\$ 6.88

(Toll Rates Effective July 1, 2023)

Note: In 2017, CFX instituted the Customer First Toll Policy.

LANES OF EQUIPMENT

- 4 Manned Booths (MB) with E-PASS
- 2 Booths with Automatic Coin Machines (ACM) and E-PASS
- 4 Open Road Tolling (ORT) E-PASS
- * Changeable Message Sign

LEGEND

- ① Lane Number
- Ⓐ Island Designation



Approx. Scale: 1" = 200'
Aerial Date: 2021

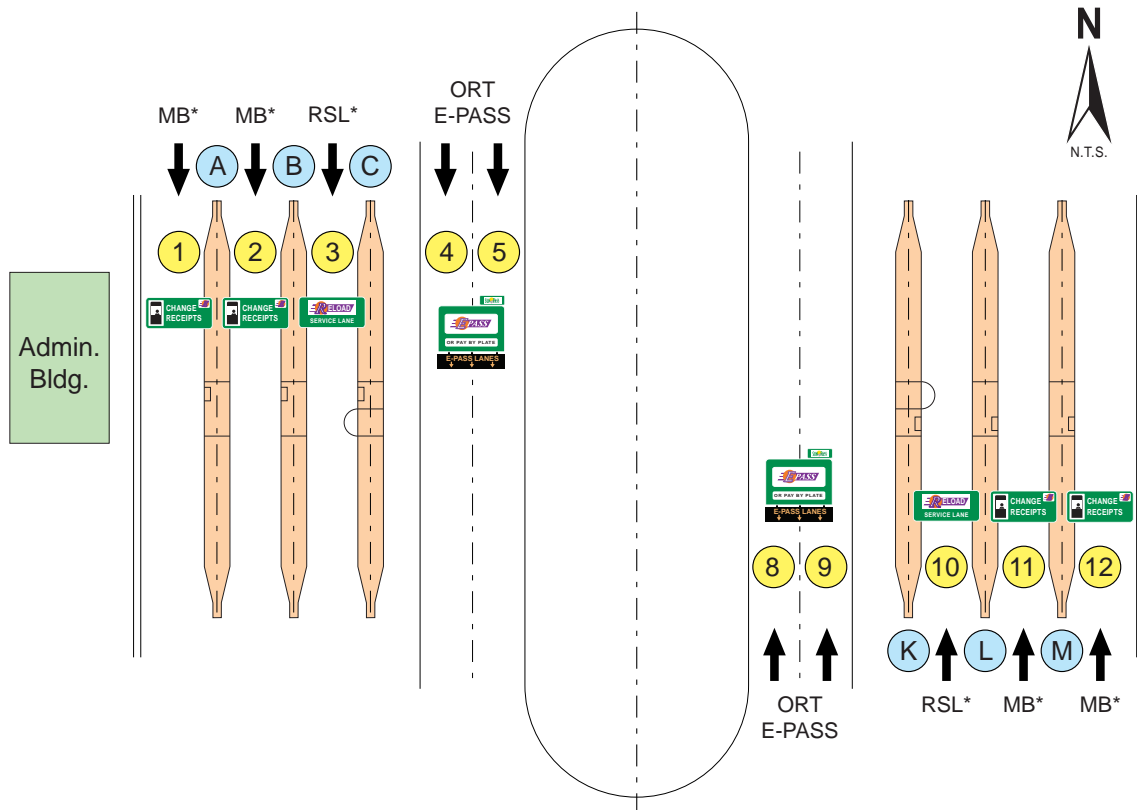

HISTORIC TRAFFIC - A.A.W.T.

2000	8,360	2008	27,000	2016	53,510
2001	13,620	2009	27,600 <i>(Toll Increase April 2009)</i>	2017	61,000
2002	16,940	2010	29,500	2018	66,700 <i>(Toll Increase July 2018)</i>
2003	20,140	2011	29,600	2019	66,280
2004	23,820	2012	31,650 <i>(Toll Increase July 2012)</i>	2020	59,680
2005	27,900	2013	34,430	2021	61,870
2006	29,200	2014	38,930	2022	64,550
2007	30,410	2015	46,360		

TOLL RATE STRUCTURE

	E-PASS	CASH	PAY-BY-PLATE
2 Axles	\$ 1.56	\$ 1.75	\$ 3.12
3 Axles	\$ 2.18	\$ 2.50	\$ 4.36
4 Axles	\$ 2.82	\$ 3.25	\$ 5.64
5 Axles or more	\$ 3.44	\$ 4.00	\$ 6.88

(Toll Rates Effective July 1, 2023)

Note: In 2017, CFX instituted the Customer First Toll Policy.

LANES OF EQUIPMENT

- 4 Manned Booths (MB) with E-PASS
- 2 Booths with Automatic Coin Machines (ACM) and E-PASS
- 4 Open Road Tolling (ORT) E-PASS
- * Changeable Message Sign

LEGEND

- ① Lane Number
- Ⓐ Island Designation



Approx. Scale: 1" = 100'
Aerial Date: 2021

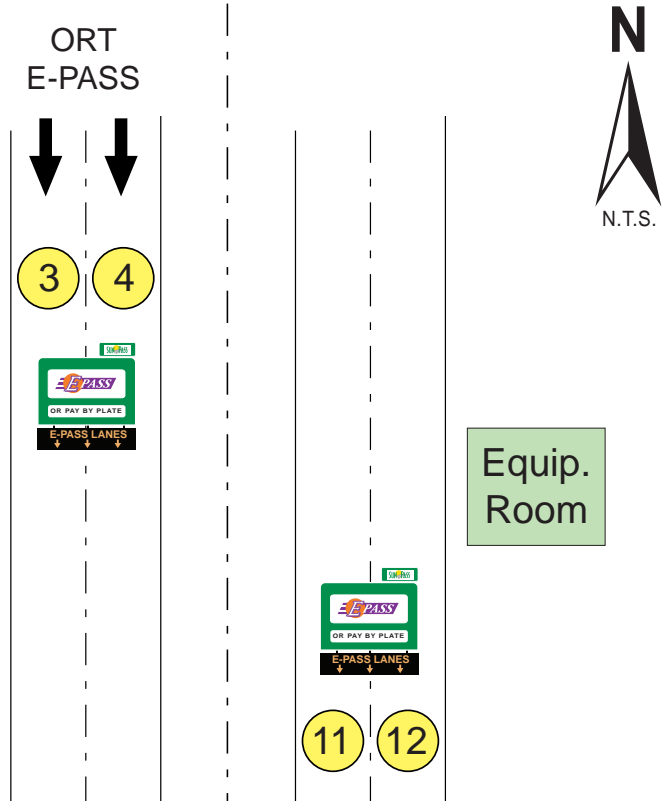

HISTORIC TRAFFIC - A.A.W.T.

2017	9,560*
2018	14,630 (Toll Increase July 2018)
2019	18,900
2020	18,530
2021	21,210
2022	23,760

TOLL RATE STRUCTURE

	<u>E-PASS</u>	<u>CASH</u>	<u>PAY-BY-PLATE</u>
2 Axles	\$.89	NA	\$ 1.78
3 Axles	\$ 1.35	NA	\$ 2.70
4 Axles	\$ 1.80	NA	\$ 3.60
5 Axles or more	\$ 2.24	NA	\$ 4.48

(Toll Rates Effective July 1, 2023)
 Note: In 2017, CFX instituted the Customer First Toll Policy.

* Opened to traffic July 28, 2017.

LANES OF EQUIPMENT

- 4 Open Road Tolling (ORT) E-PASS and Pay-by-Plate (PBP)

LEGEND

① Lane Number



Ponkan Toll Gantry Facility
 SR 429 (WEKIVA PARKWAY)



Approx. Scale: 1" = 100'
Aerial Date: 2021

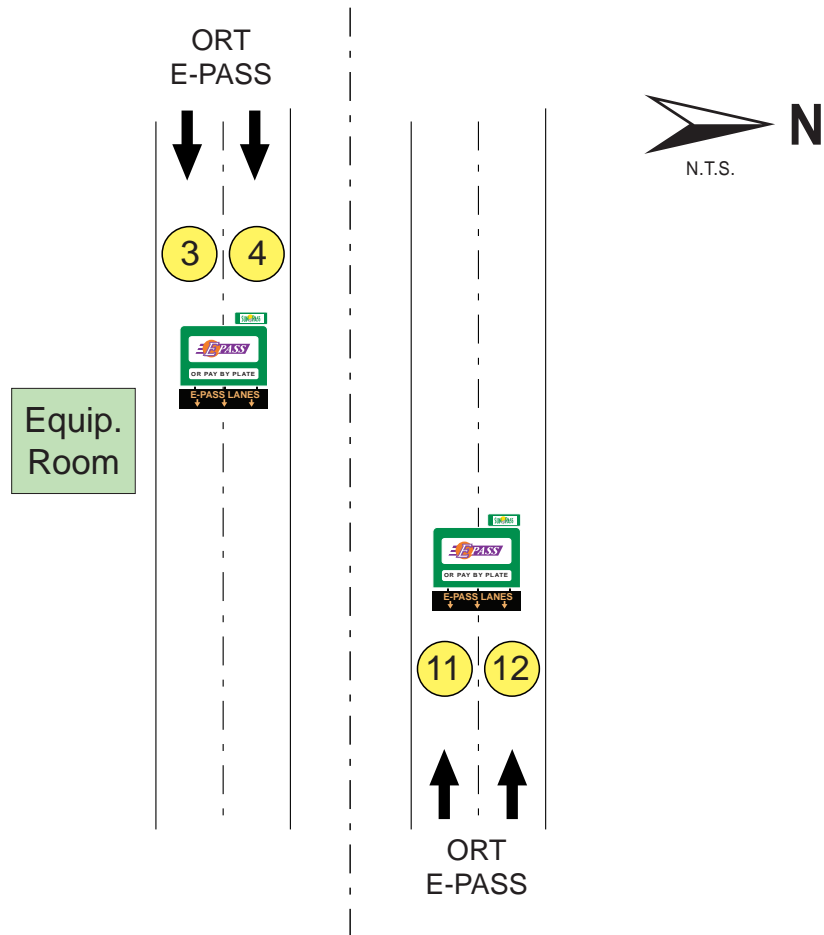

HISTORIC TRAFFIC - A.A.W.T.

2018	5,270* (Toll Increase July 2018)
2019	5,850
2020	4,690
2021	5,910
2022	8,930

TOLL RATE STRUCTURE

	<u>E-PASS</u>	<u>CASH</u>	<u>PAY-BY-PLATE</u>
2 Axles	\$.84	NA	\$ 1.68
3 Axles	\$ 1.28	NA	\$ 2.56
4 Axles	\$ 1.67	NA	\$ 3.34
5 Axles or more	\$ 2.11	NA	\$ 4.22

(Toll Rates Effective July 1, 2023)

Note: In 2017, CFX instituted the Customer First Toll Policy.

* Opened to traffic April 1, 2018

LANES OF EQUIPMENT

- 4 Open Road Tolling (ORT) E-PASS and Pay-by-Plate (PBP)

LEGEND

- ① Lane Number

Mainline Toll Facility (Apopka Expressway)





Approx. Scale: 1" = 200'
Aerial Date: 2021

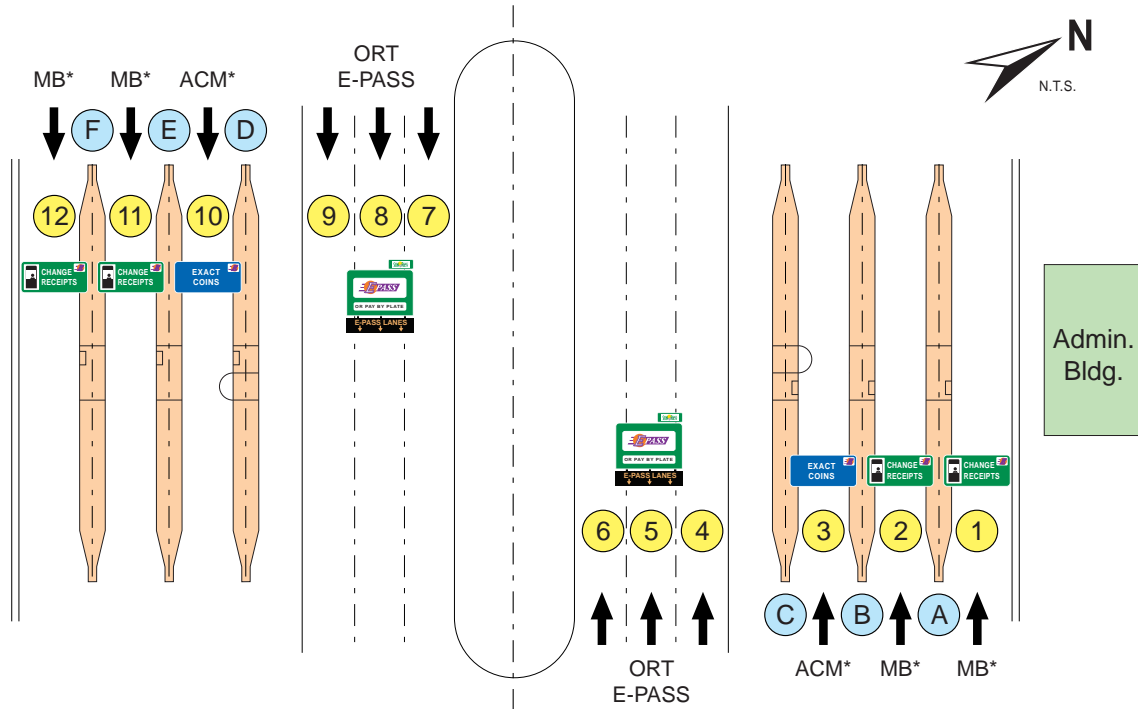

HISTORIC TRAFFIC - A.A.W.T.

2009	10,500	2014	24,120	2019	42,840
2010	13,025	2015	29,100	2020	37,360
2011	13,820	2016	33,900	2021	40,070
2012	16,320 (Toll Increase July 2012)	2017	36,930	2022	42,840
2013	20,870	2018	41,570 (Toll Increase July 2018)		

TOLL RATE STRUCTURE

	<u>E-PASS</u>	<u>CASH</u>	<u>PAY-BY-PLATE</u>
2 Axles	\$ 1.25	\$ 1.50	\$ 2.50
3 Axles	\$ 1.89	\$ 2.25	\$ 3.78
4 Axles	\$ 2.49	\$ 2.75	\$ 4.98
5 Axles or more	\$ 3.13	\$ 3.50	\$ 6.26

(Toll Rates Effective July 1, 2023)

Note: In 2017, CFX instituted the Customer First Toll Policy.

LANES OF EQUIPMENT

- 4 Manned Booths (MB) with E-PASS
- 2 Booths with Automatic Coin Machines (ACM) and E-PASS
- 6 Open Road Tolling (ORT) E-PASS
- * Changeable Message Sign

LEGEND

- ① Lane Number
- Ⓐ Island Designation

Mainline Toll Gantry Facility (SR 453)





Approx. Scale: 1" = 100'
Aerial Date: 2021

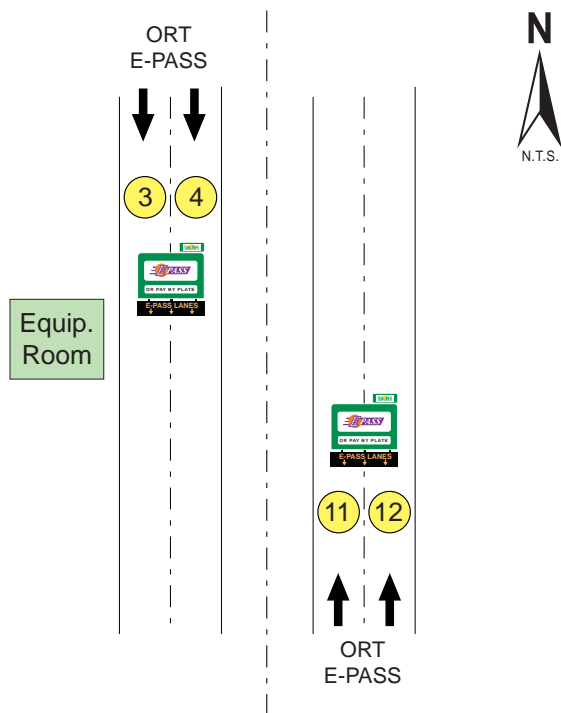

HISTORIC TRAFFIC - A.A.W.T.

2018	3,690* (Toll Increase July 2018)	2021	13,550
2019	9,320	2022	17,140
2020	11,210		

TOLL RATE STRUCTURE

	<u>E-PASS</u>	<u>CASH</u>	<u>PAY-BY-PLATE</u>
2 Axles	\$.72	NA	\$ 1.44
3 Axles	\$ 1.11	NA	\$ 2.22
4 Axles	\$ 1.46	NA	\$ 2.92
5 Axles or more	\$ 1.85	NA	\$ 3.70

(Toll Rates Effective July 1, 2023)

Note: In 2017, CFX instituted the Customer First Toll Policy.

* Opened to traffic April 1, 2018.

LANES OF EQUIPMENT

- 4 Open Road Tolling (ORT) E-PASS and Pay-by-Plate (PBP)

LEGEND

- ① Lane Number

Mainline Toll Gantry Facilities (Poinciana Parkway)



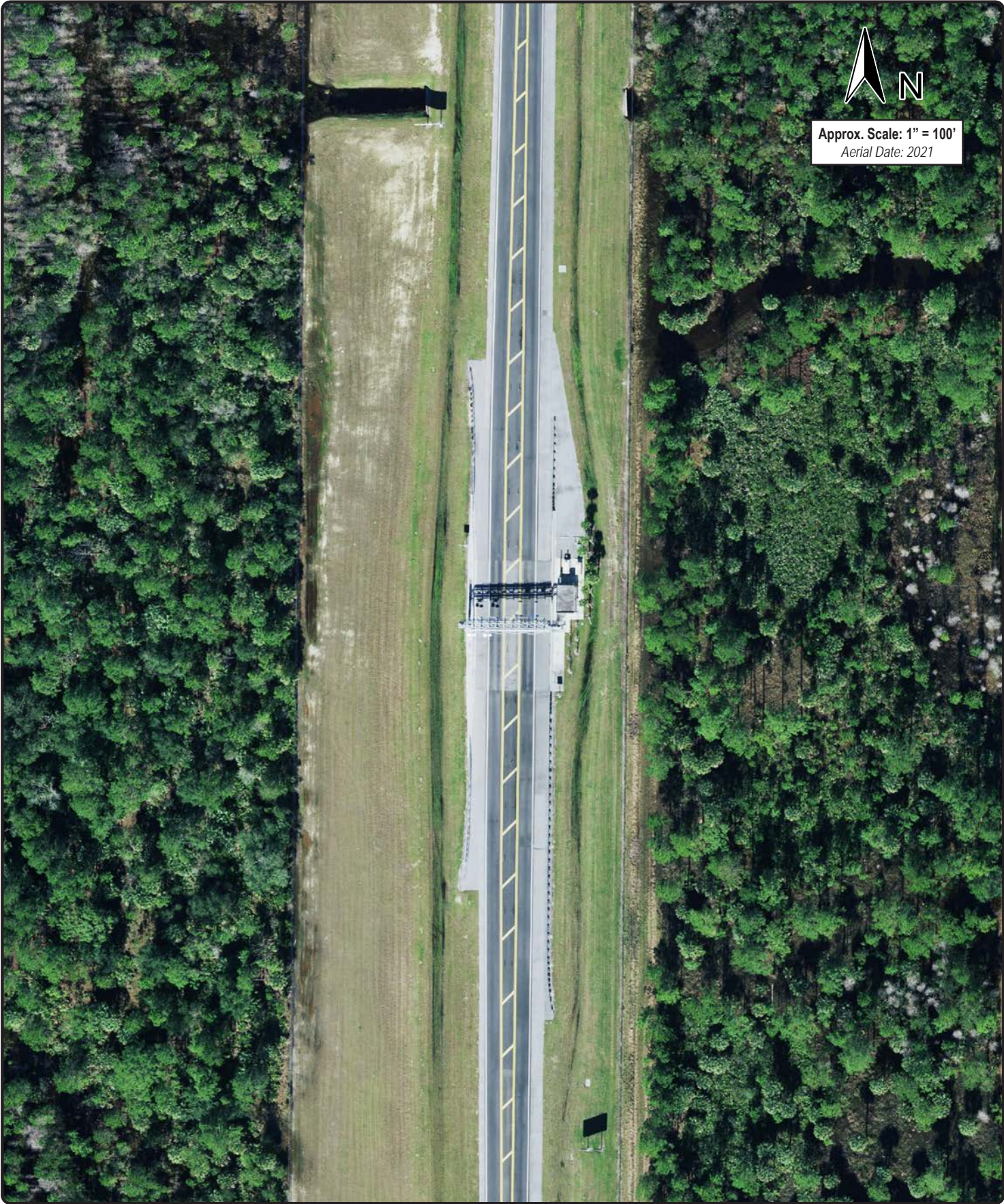

Approx. Scale: 1" = 100'
Aerial Date: 2021

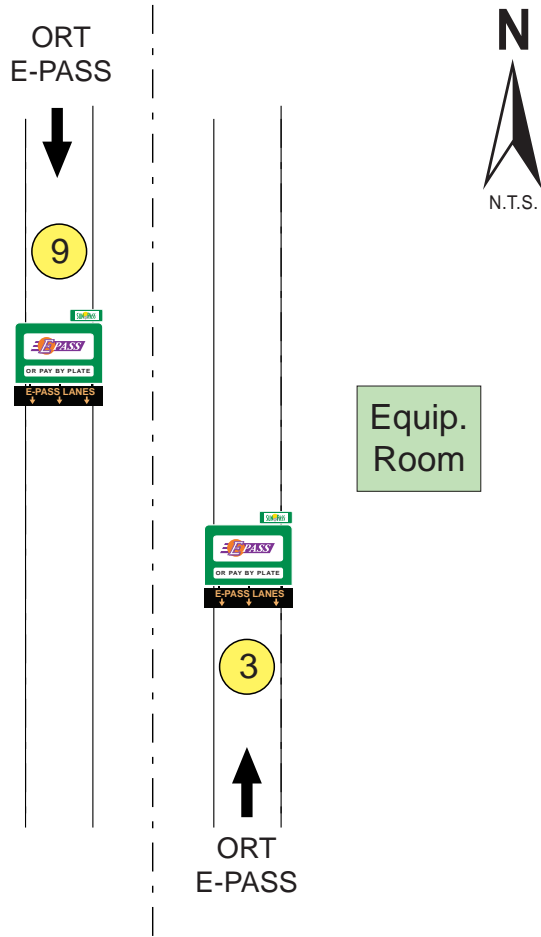

HISTORIC TRAFFIC - A.A.W.T.

2019	10,740	2022	14,830
2020	10,940		
2021	13,060		

TOLL RATE STRUCTURE

	<u>E-PASS</u>	<u>CASH</u>	<u>PAY-BY-PLATE</u>
2 Axles	\$ 2.22	NA	\$ 4.44
3 Axles	\$ 3.36	NA	\$ 6.72
4 Axles	\$ 4.43	NA	\$ 8.86
5 Axles or more	\$ 5.58	NA	\$11.16

(Toll Rates Effective July 1, 2023)

Note: In 2017, CFX instituted the Customer First Toll Policy.

** Opened to traffic April 2016.*

LANES OF EQUIPMENT

- 2 Open Road Tolling (ORT) E-PASS and Pay-by-Plate (PBP)

LEGEND

- ① Lane Number





Approx. Scale: 1" = 100'
Aerial Date: 2021

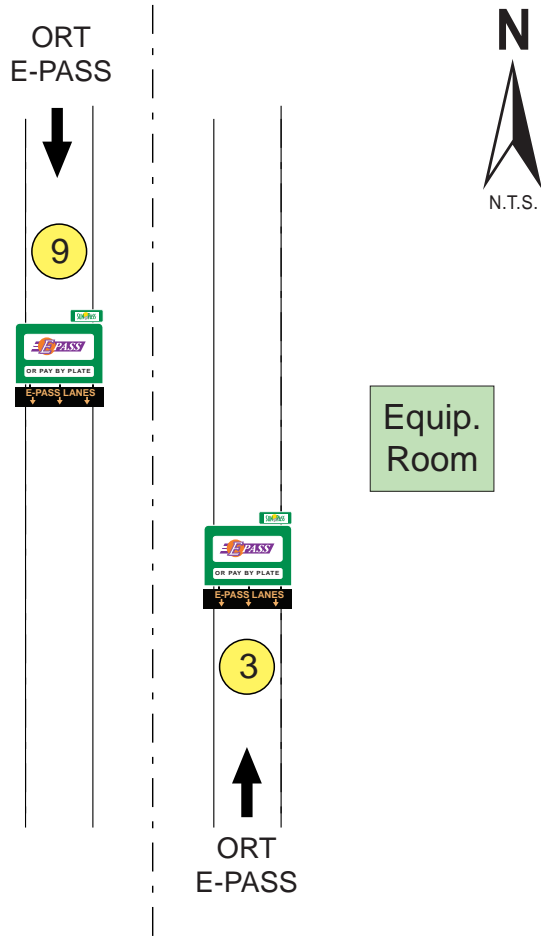

HISTORIC TRAFFIC - A.A.W.T.

2019	4,560	2022	7,560
2020	5,330		
2021	6,660		

TOLL RATE STRUCTURE

	<u>E-PASS</u>	<u>CASH</u>	<u>PAY-BY-PLATE</u>
2 Axles	\$.55	NA	\$ 1.10
3 Axles	\$.81	NA	\$ 1.62
4 Axles	\$ 1.09	NA	\$ 2.18
5 Axles or more	\$ 1.36	NA	\$ 2.72

(Toll Rates Effective July 1, 2023)

Note: In 2017, CFX instituted the Customer First Toll Policy.

** Opened to traffic November 2016.*

LANES OF EQUIPMENT

- 2 Open Road Tolling (ORT) E-PASS and Pay-by-Plate (PBP)

LEGEND

- ① Lane Number



Koa Mainline Toll Gantry Facility
SR 538 (POINCIANA PARKWAY)

Goldenrod Mainline Toll Facility (Goldenrod Road Extension)



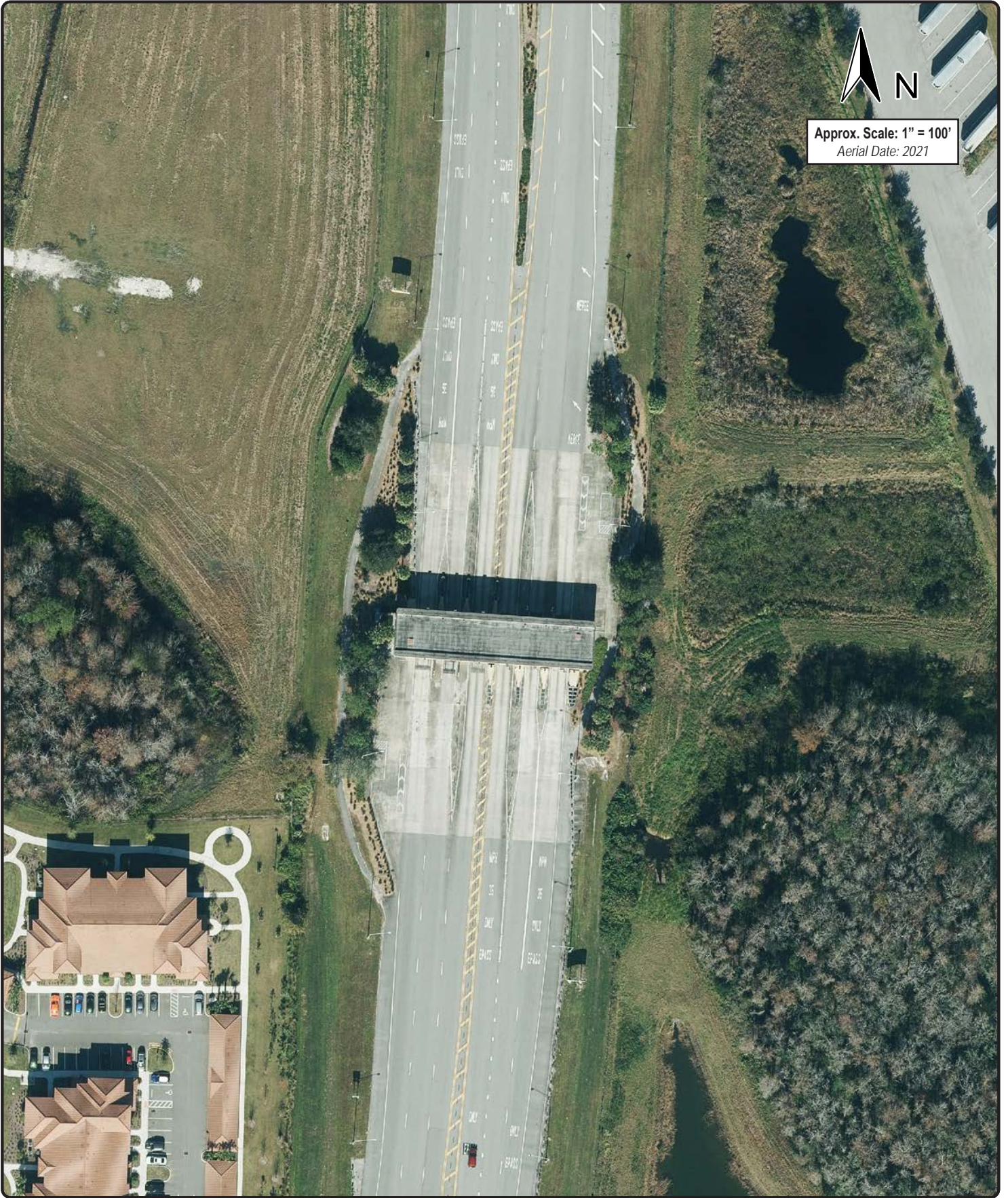

Approx. Scale: 1" = 100'
Aerial Date: 2021

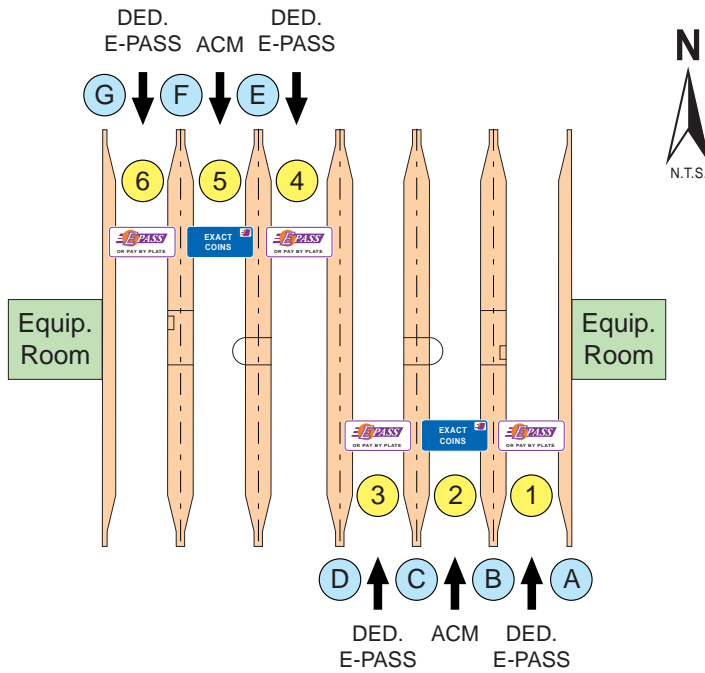

HISTORIC TRAFFIC - A.A.W.T.

2016	12,000	2020	No data
2017	13,510	2021	No data
2018	14,340 (Toll Increase July 2018)	2022	No data
2019	No data		

TOLL RATE STRUCTURE

	<u>E-PASS</u>	<u>CASH</u>	<u>PAY-BY-PLATE</u>
2 Axles	\$.50	\$.50	\$ 1.00
3 Axles	\$.50	\$.50	\$ 1.00
4 Axles	\$.50	\$.50	\$ 1.00
5 Axles or more	\$.50	\$.50	\$ 1.00

(Toll Rates Effective July 1, 2022)

Note: In 2017, CFX instituted the Customer First Toll Policy.

LANES OF EQUIPMENT

- 2 Booths with Automatic Coin Machines (ACM) and E-PASS
- 4 Dedicated E-PASS only

LEGEND

- ① Lane Number
- Ⓐ Island Designation

SECTION IV: Interchanges



EAST-WEST EXPRESSWAY



2022 Traffic Data and Statistics Manual
CENTRAL FLORIDA EXPRESSWAY AUTHORITY

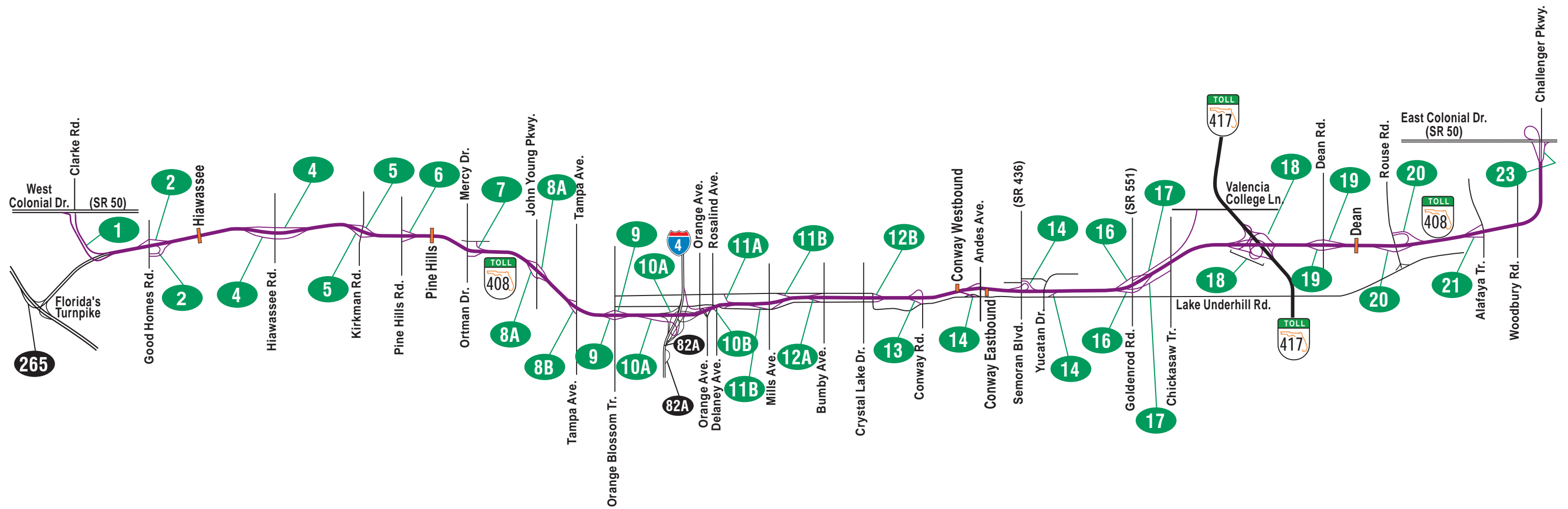

LEGEND

- Exit Number
- Existing SR 408
- Mainline Toll Plaza

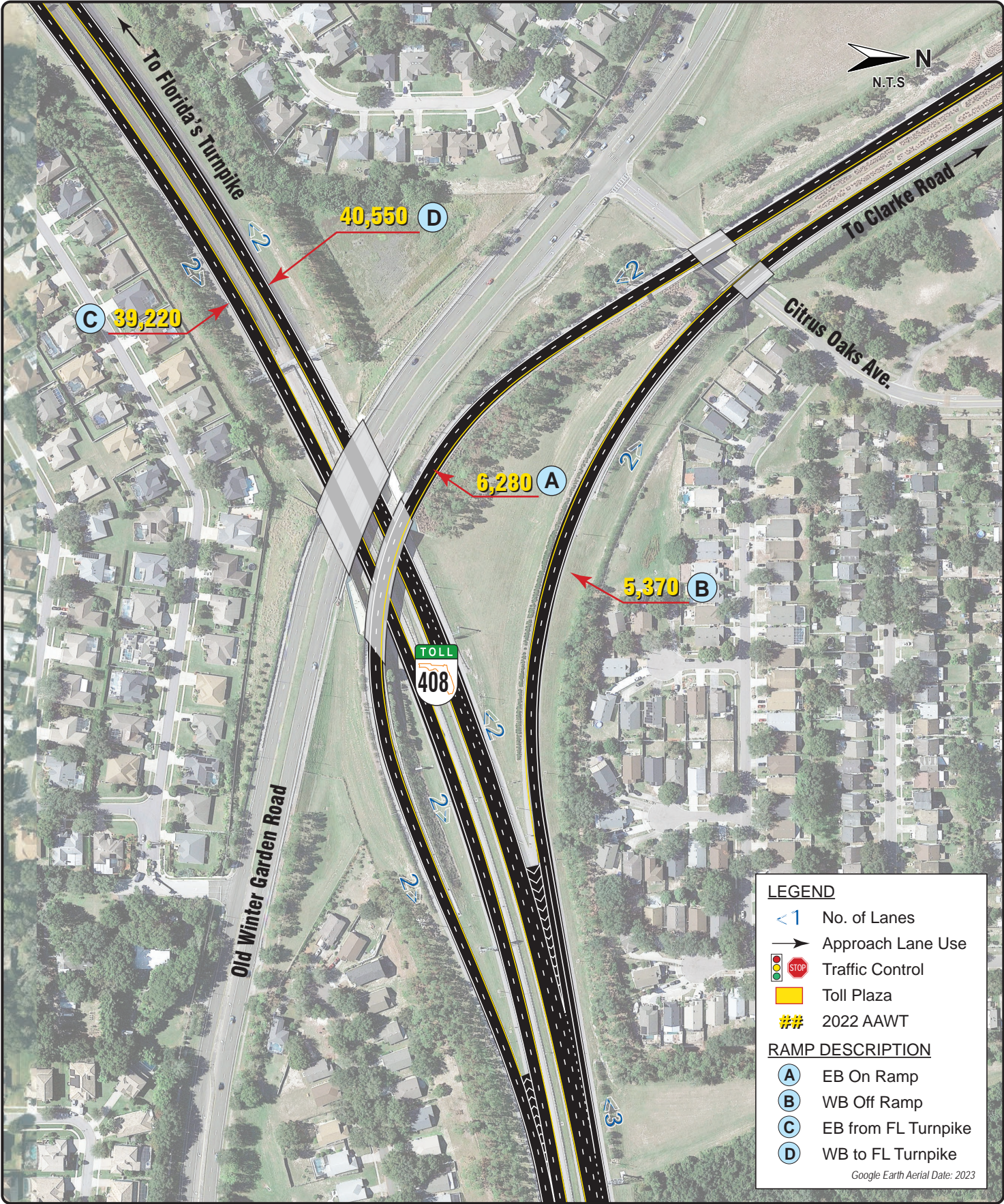

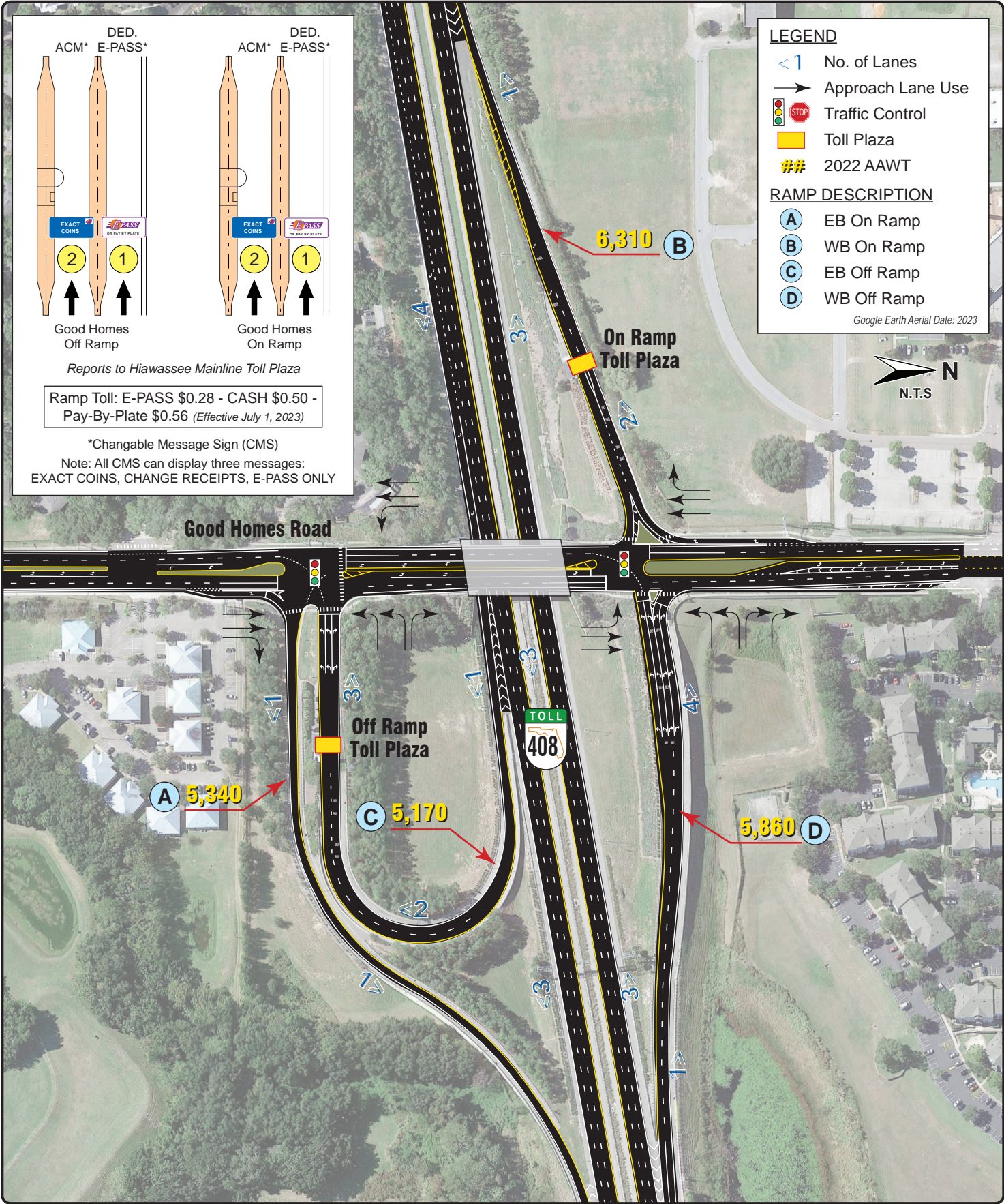

LEGEND

- <1 No. of Lanes
- Approach Lane Use
- 🚦 Traffic Control
- 🟡 Toll Plaza
- ## 2022 AAWT

RAMP DESCRIPTION

- (A) EB On Ramp
- (B) WB On Ramp
- (C) EB Off Ramp
- (D) WB Off Ramp

Google Earth Aerial Date: 2023



DED. ACM* E-PASS*

Good Homes Off Ramp

DED. ACM* E-PASS*

Good Homes On Ramp

Reports to Hiwassee Mainline Toll Plaza

Ramp Toll: E-PASS \$0.28 - CASH \$0.50 - Pay-By-Plate \$0.56 (Effective July 1, 2023)

*Changable Message Sign (CMS)
 Note: All CMS can display three messages: EXACT COINS, CHANGE RECEIPTS, E-PASS ONLY

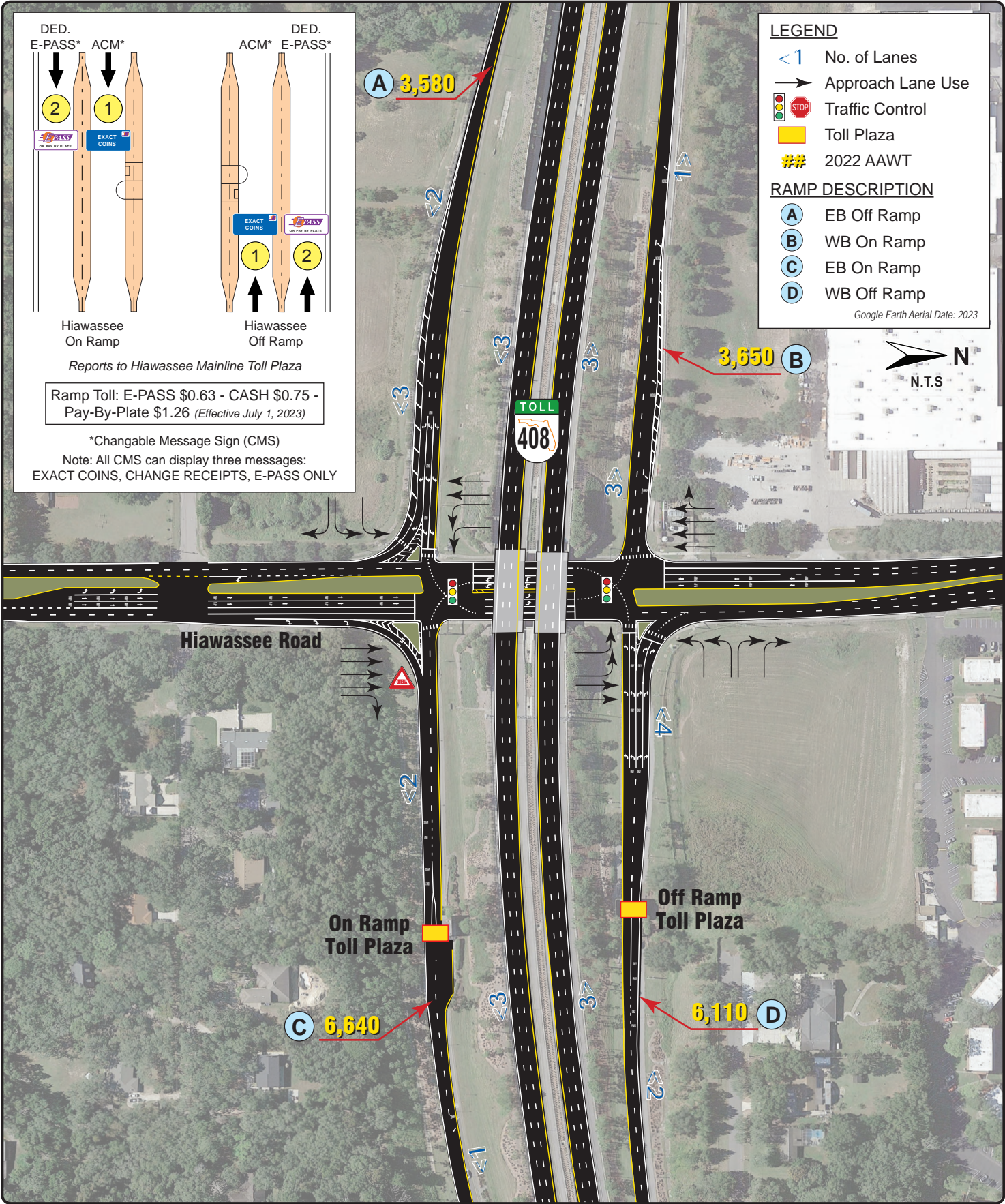

LEGEND

- <1 No. of Lanes
- Approach Lane Use
- STOP Traffic Control
- Yellow Box Toll Plaza
- ## 2022 AAWT

RAMP DESCRIPTION

- (A) EB Off Ramp
- (B) WB On Ramp
- (C) EB On Ramp
- (D) WB Off Ramp

Google Earth Aerial Date: 2023

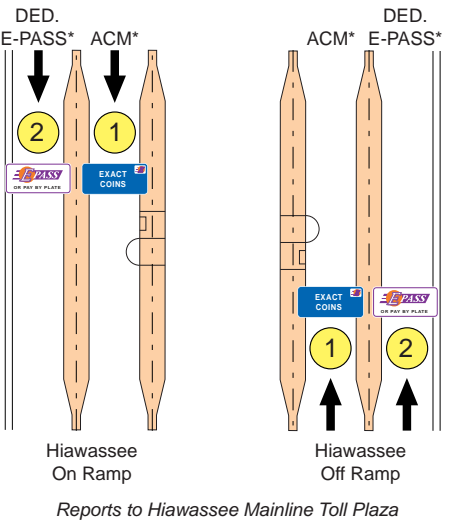

Ramp Toll: E-PASS \$0.63 - CASH \$0.75 - Pay-By-Plate \$1.26 (Effective July 1, 2023)

*Changable Message Sign (CMS)

Note: All CMS can display three messages: EXACT COINS, CHANGE RECEIPTS, E-PASS ONLY

LEGEND

- <1 No. of Lanes
- Approach Lane Use
- STOP Traffic Control
- Toll Plaza
- ## 2022 AAWT

RAMP DESCRIPTION

- A EB Off Ramp
- B WB On Ramp
- C EB On Ramp
- D WB Off Ramp

Google Earth Aerial Date: 2023

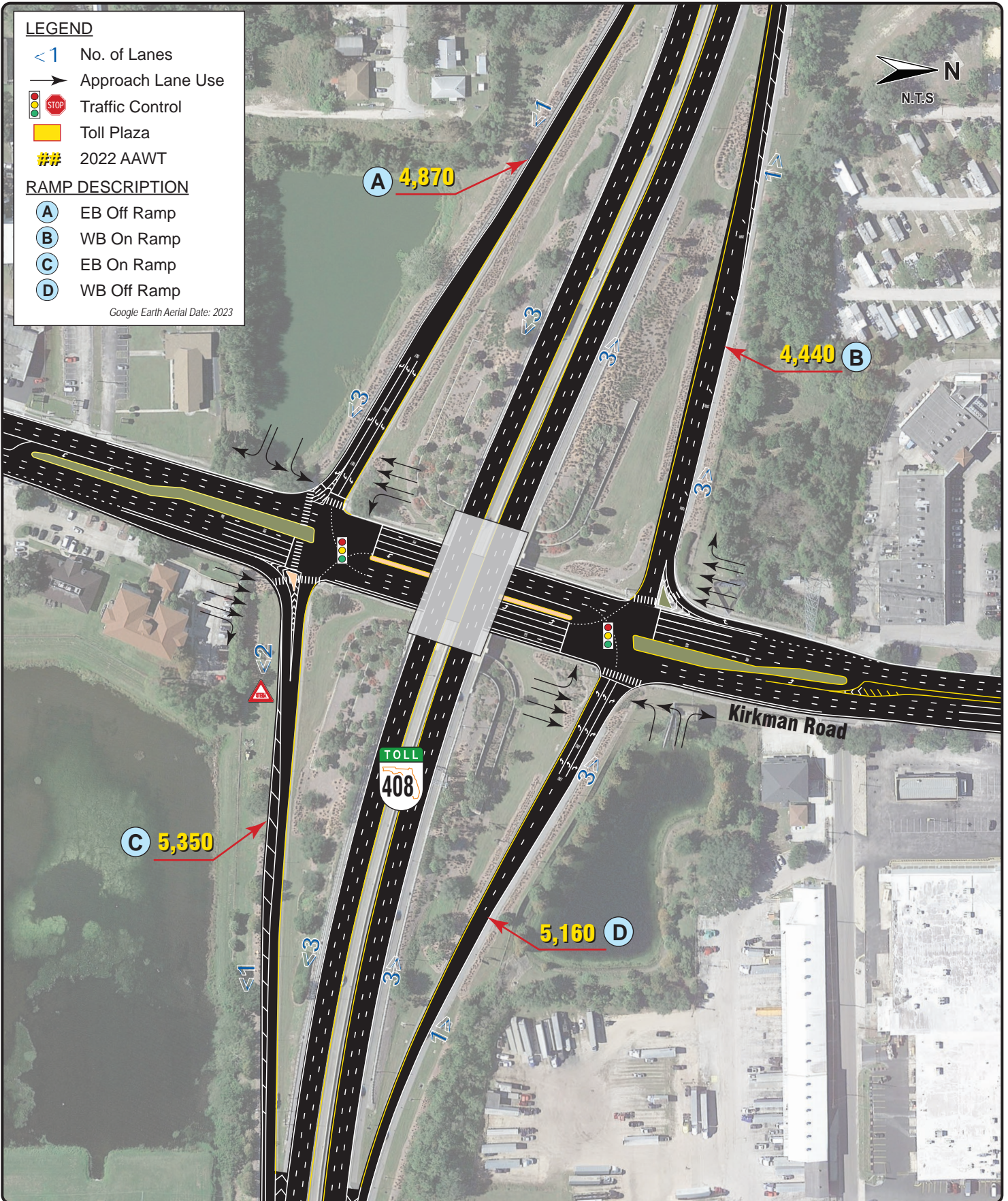

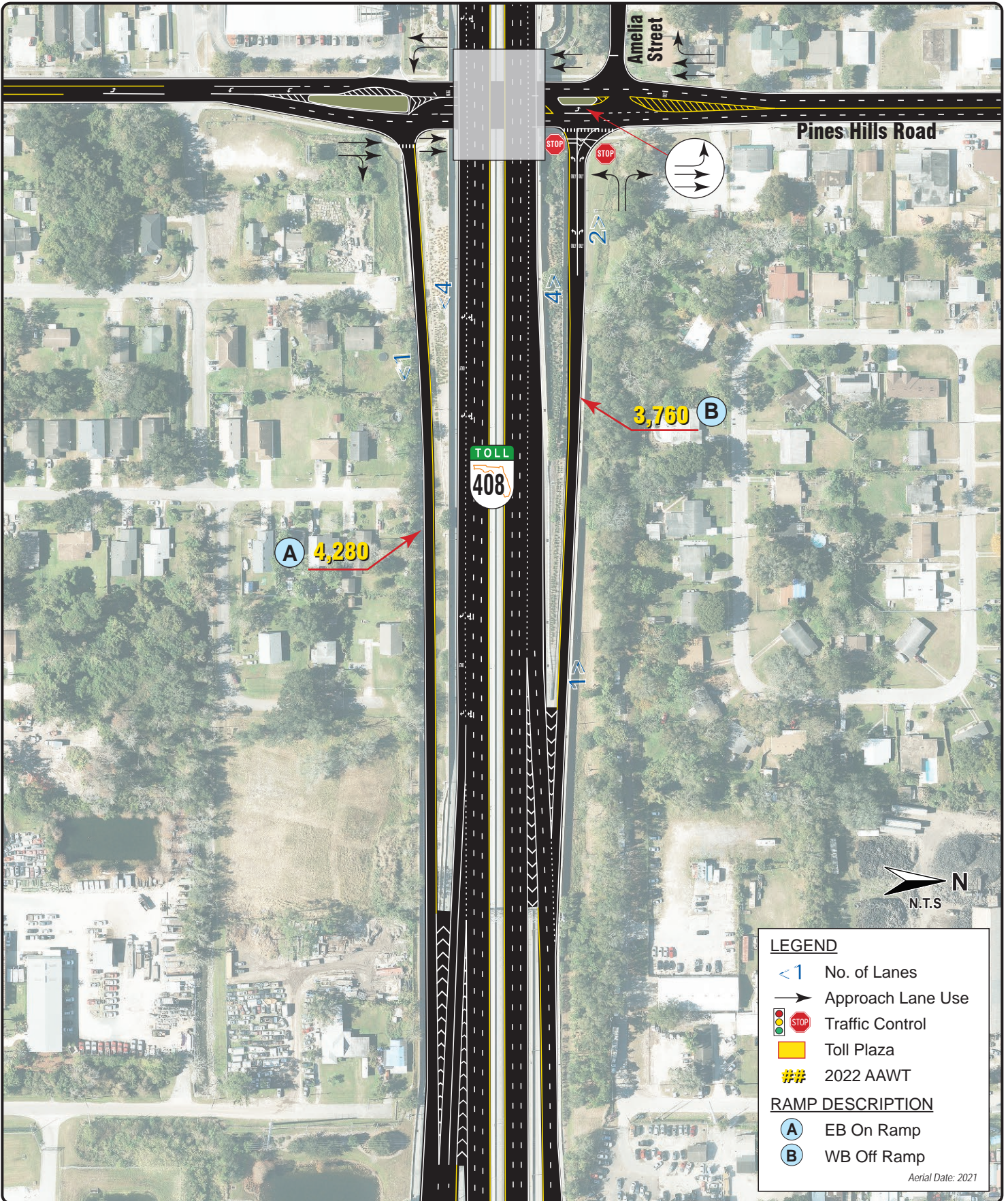

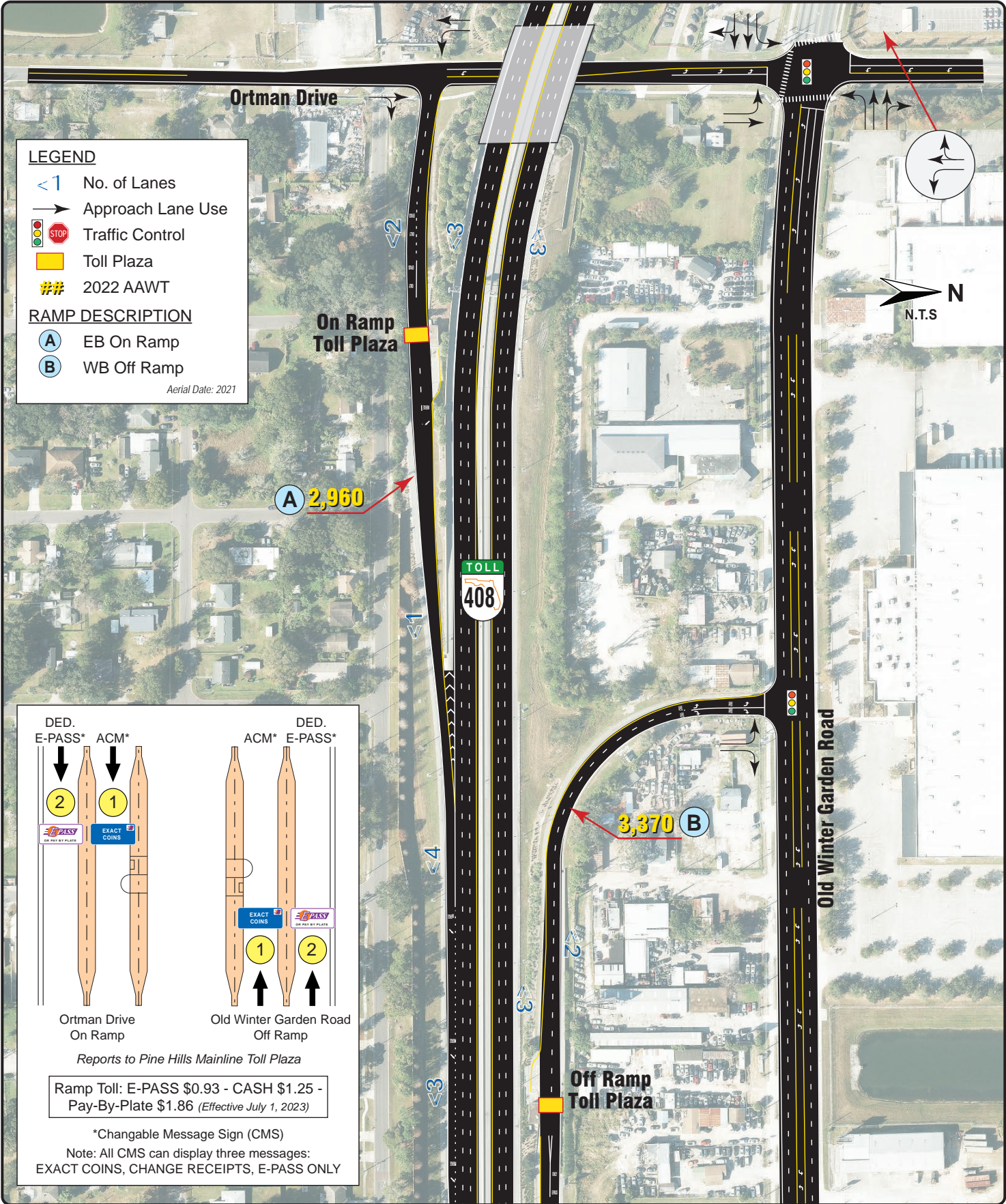

LEGEND

- <1 No. of Lanes
- ➔ Approach Lane Use
- Traffic Control
- Toll Plaza
- ## 2022 AAWT

RAMP DESCRIPTION

- A** EB Off Ramp
- B** WB On Ramp
- C** EB On Ramp
- D** WB Off Ramp

Aerial Date: 2021

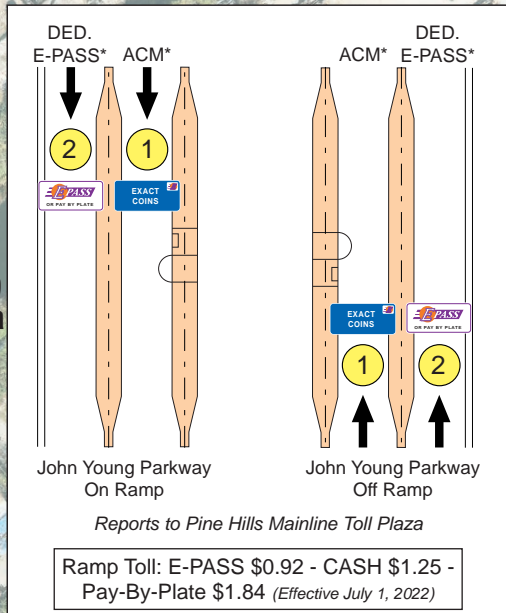
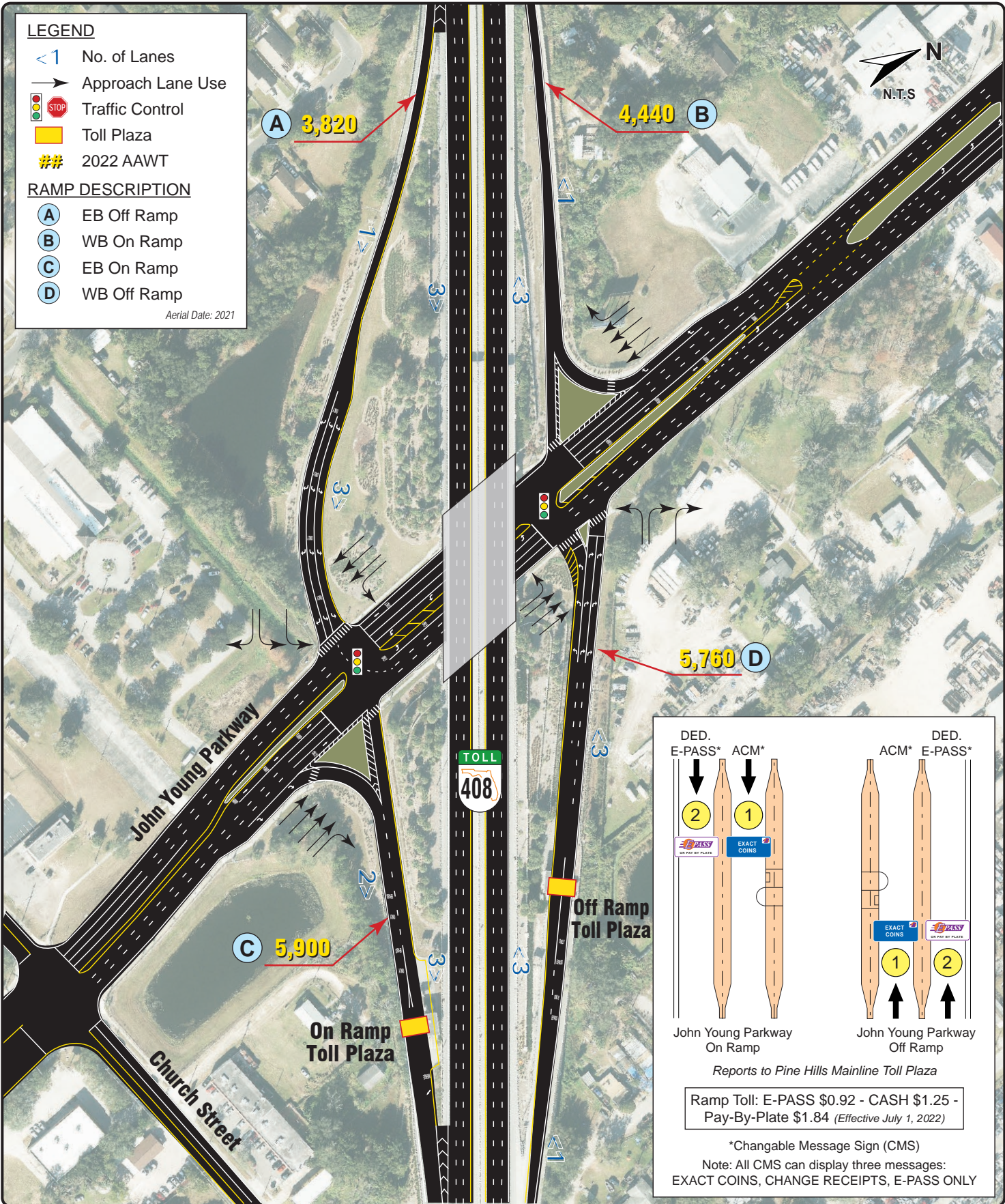

*Changable Message Sign (CMS)
 Note: All CMS can display three messages:
 EXACT COINS, CHANGE RECEIPTS, E-PASS ONLY



Exit 8A - John Young Parkway
 SR 408 (EAST-WEST EXPRESSWAY)

SECTION IV

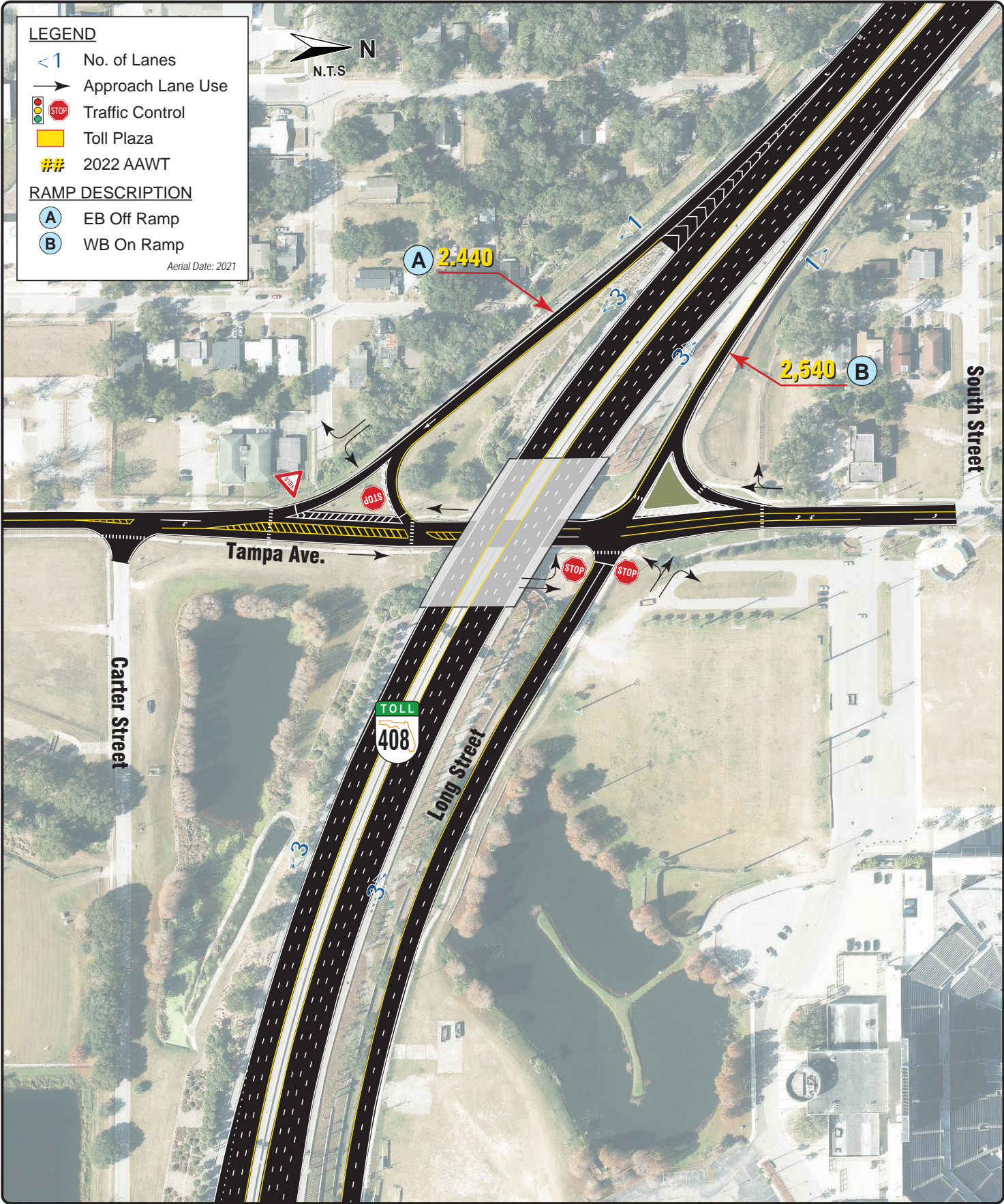

LEGEND

- <1 No. of Lanes
- Approach Lane Use
- STOP Traffic Control
- Toll Plaza
- ## 2022 AAWT

RAMP DESCRIPTION

- A EB Off Ramp
- B WB On Ramp

Aerial Date: 2021

LEGEND

- <1 No. of Lanes
- Approach Lane Use
- STOP Traffic Control
- Yellow Box Toll Plaza
- ## 2021 AAWT

RAMP DESCRIPTION

- A EB Off Ramp
- B WB On Ramp
- C EB On Ramp
- D WB Off Ramp

Aerial Date: 2021

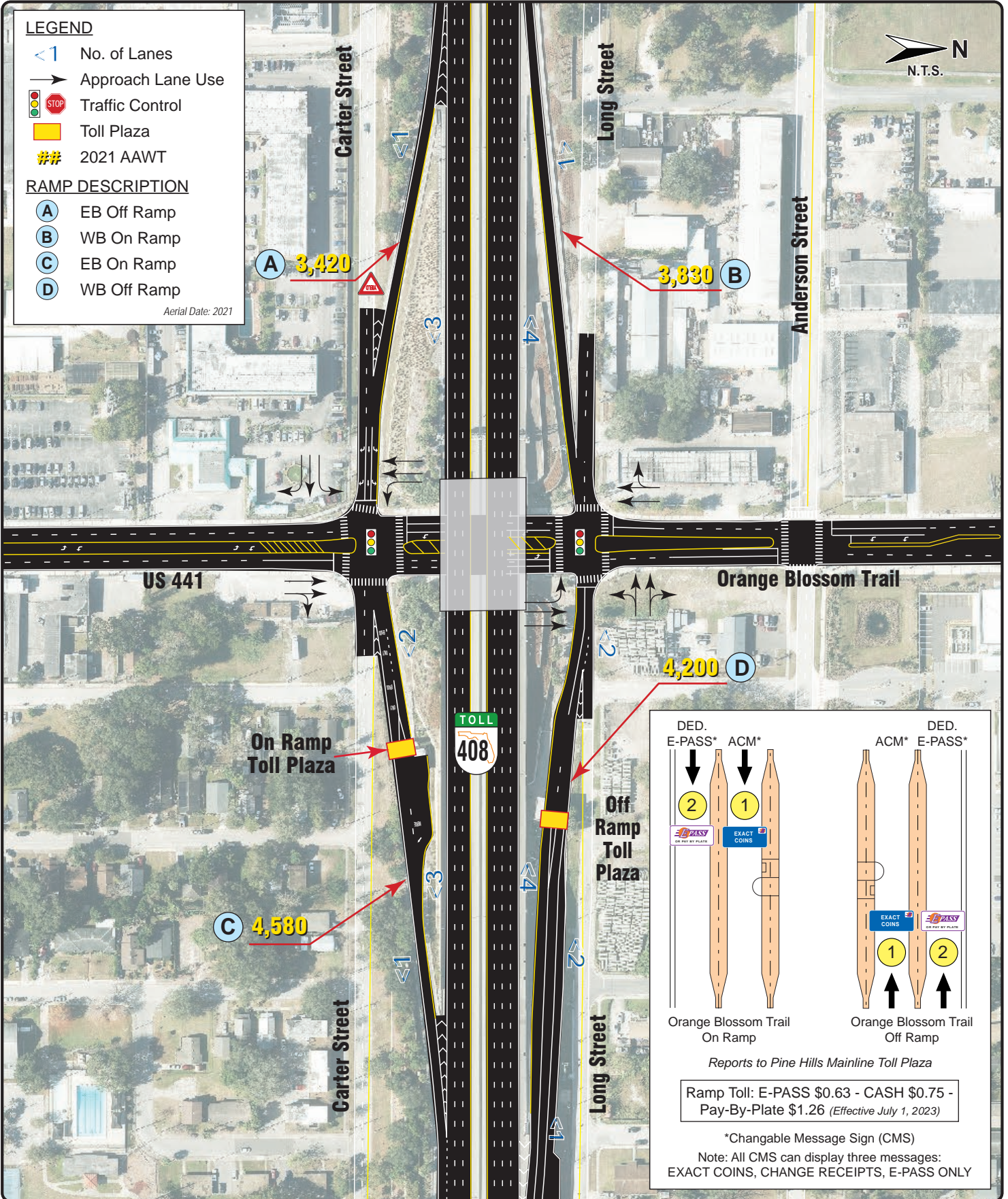

DED. E-PASS*	ACM*	DED. ACM*	E-PASS*
 Orange Blossom Trail On Ramp	 Orange Blossom Trail On Ramp	 Orange Blossom Trail Off Ramp	 Orange Blossom Trail Off Ramp
Reports to Pine Hills Mainline Toll Plaza			
Ramp Toll: E-PASS \$0.63 - CASH \$0.75 - Pay-By-Plate \$1.26 (Effective July 1, 2023)			

*Changeable Message Sign (CMS)
 Note: All CMS can display three messages:
 EXACT COINS, CHANGE RECEIPTS, E-PASS ONLY



Exit 9 - Orange Blossom Trail (US 441)
 SR 408 (EAST-WEST EXPRESSWAY)

SECTION IV

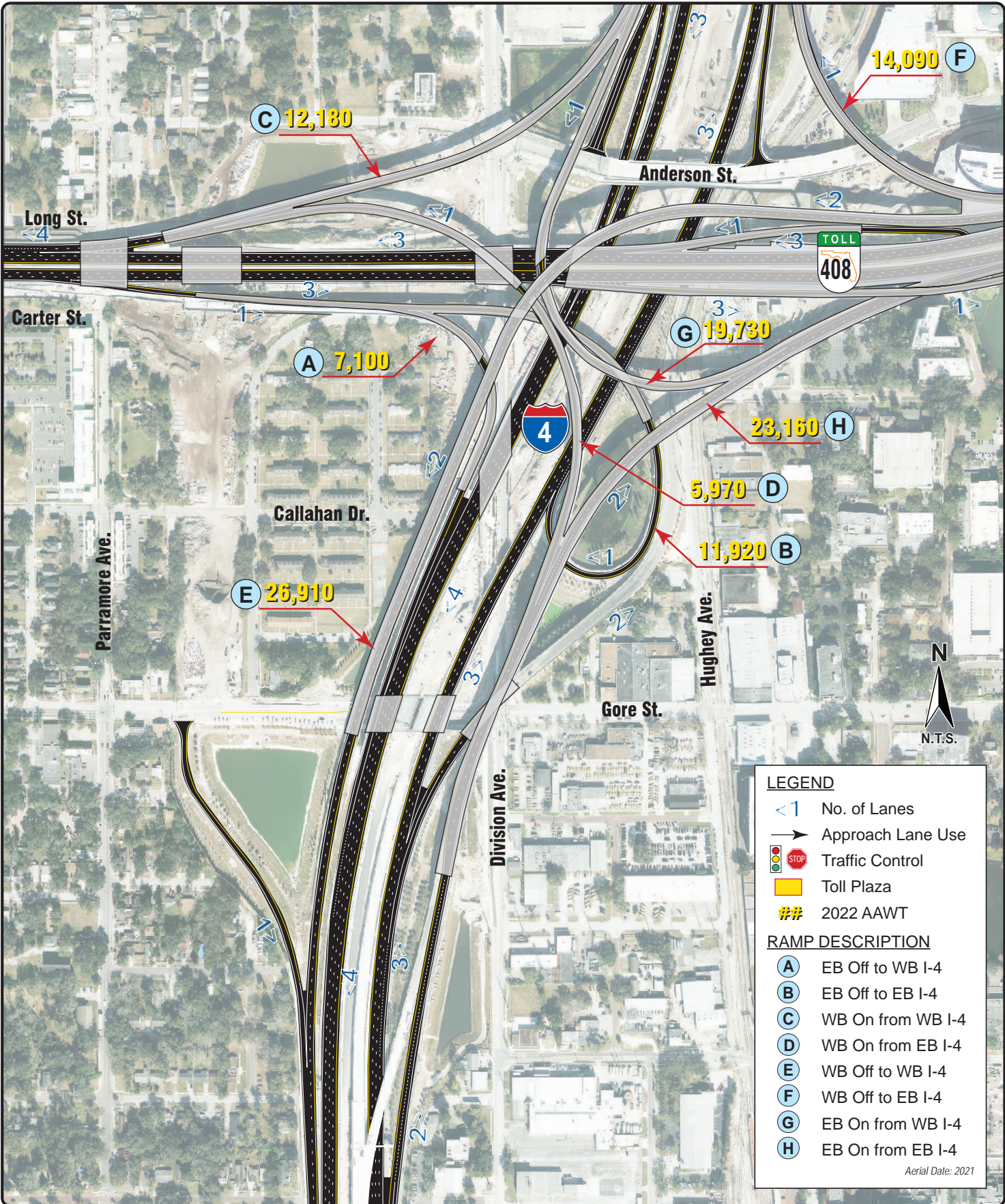



LEGEND

- < 1 No. of Lanes
- Approach Lane Use
- 🚦 STOP Traffic Control
- 🟡 Toll Plaza
- ## 2022 AAWT



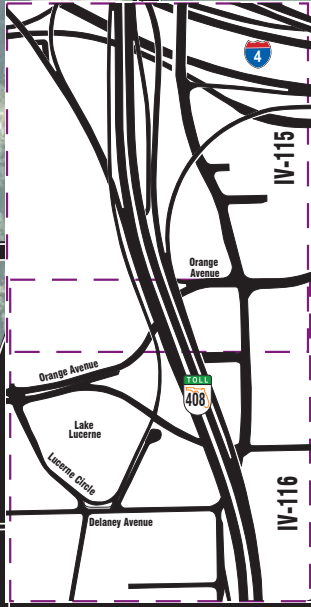

RAMP DESCRIPTION

- Ⓐ EB off Ramp
- Ⓑ WB on Ramp

Aerial Date: 2021



LEGEND

-  No. of Lanes
-  Approach Lane Use
-  Traffic Control
-  Toll Plaza
-  2022 AAWT

RAMP DESCRIPTION



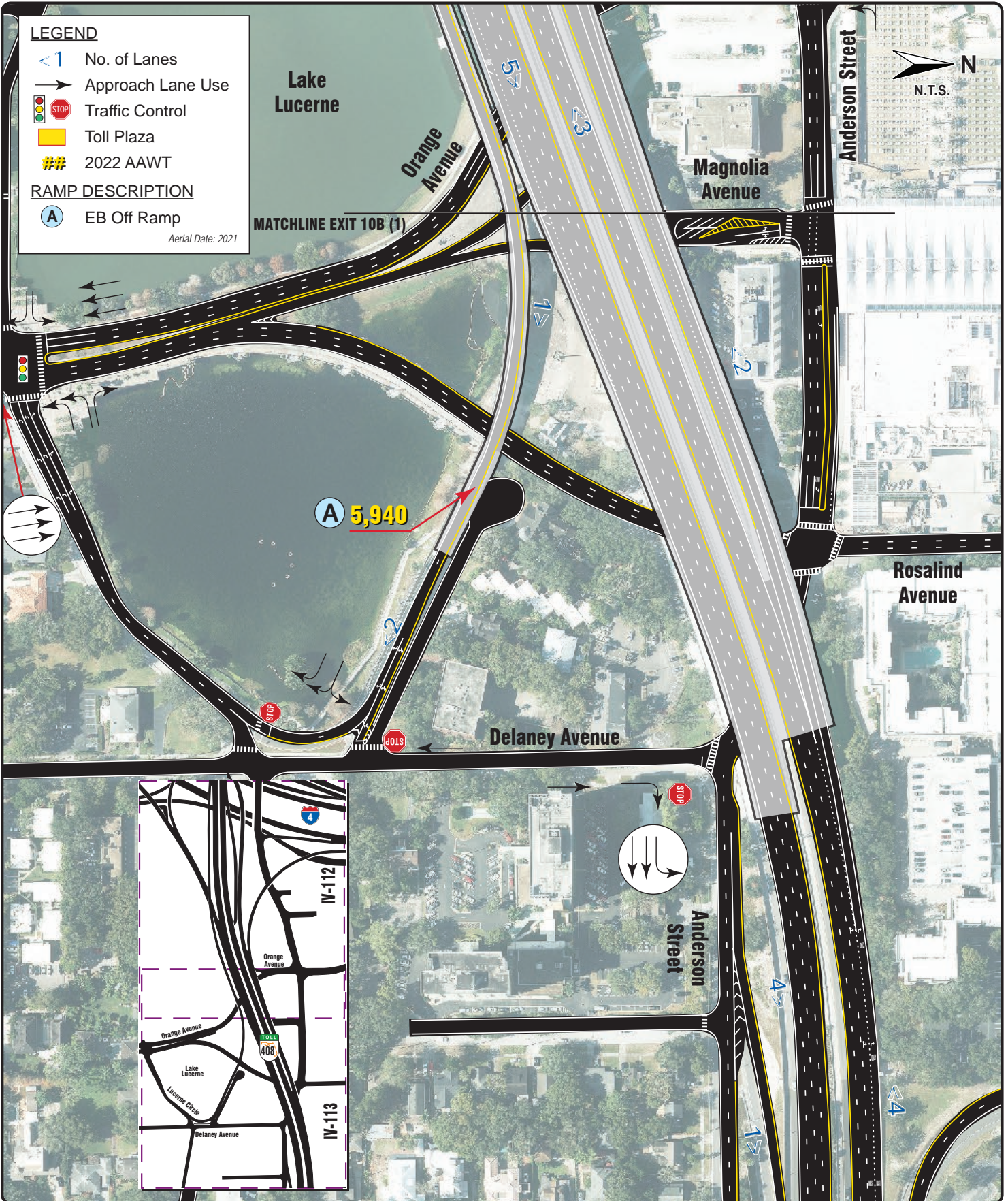

-  EB Off Ramp

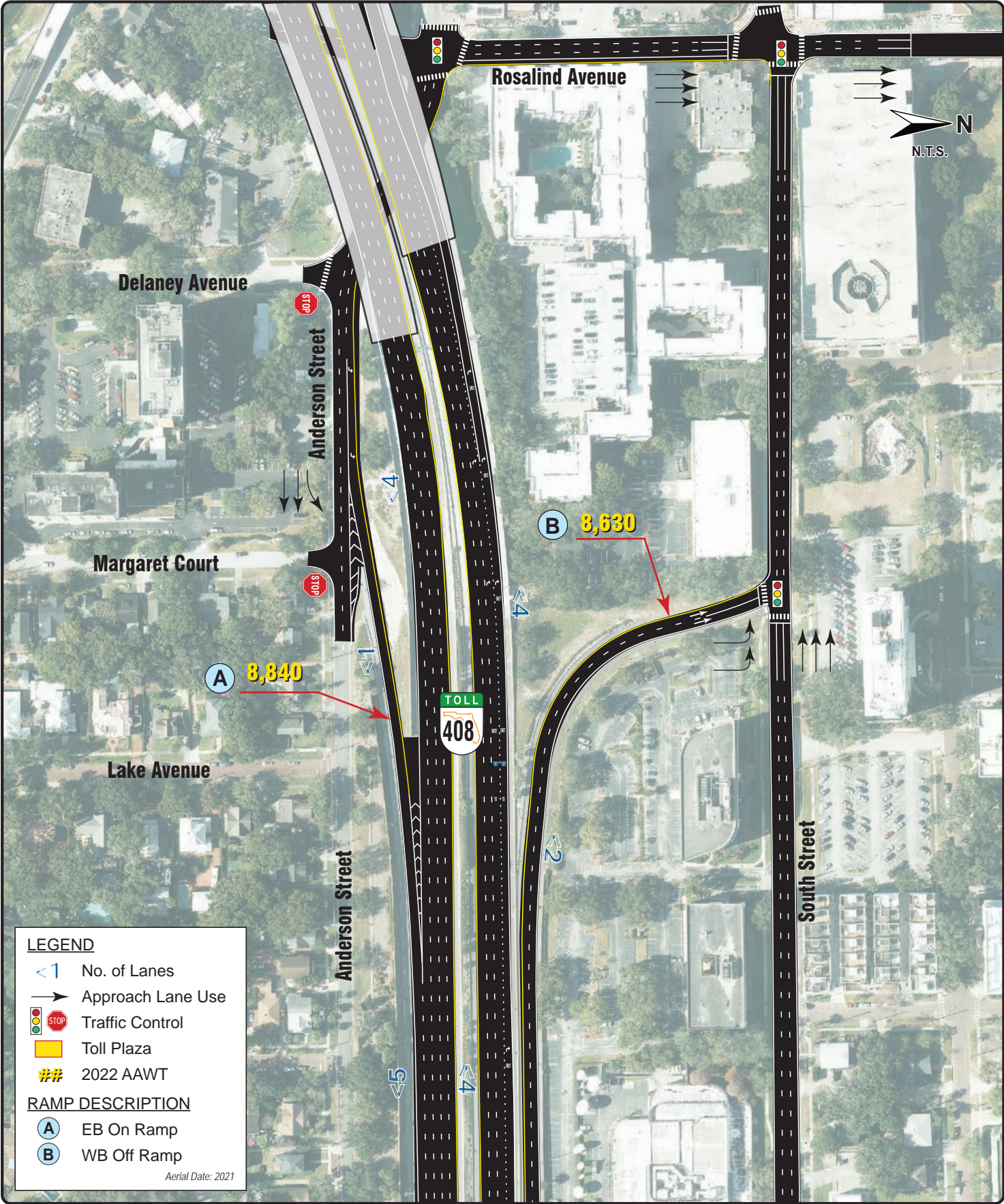
Aerial Date: 2021







LEGEND

-  No. of Lanes
-  Approach Lane Use
-  Traffic Control
-  Toll Plaza
-  2022 AAWT

RAMP DESCRIPTION

-  EB Off Ramp
-  EB On Ramp
-  WB Off Ramp

Aerial Date: 2021

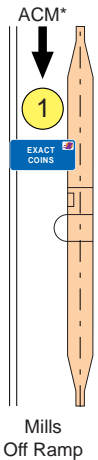

Reports to Pine Hills Mainline Toll Plaza

Ramp Toll: E-PASS \$0.63 - CASH \$0.75 - Pay-By-Plate \$1.26 (Effective July 1, 2023)

*Changable Message Sign (CMS)

Note: All CMS can display three messages: EXACT COINS, CHANGE RECEIPTS, E-PASS ONLY

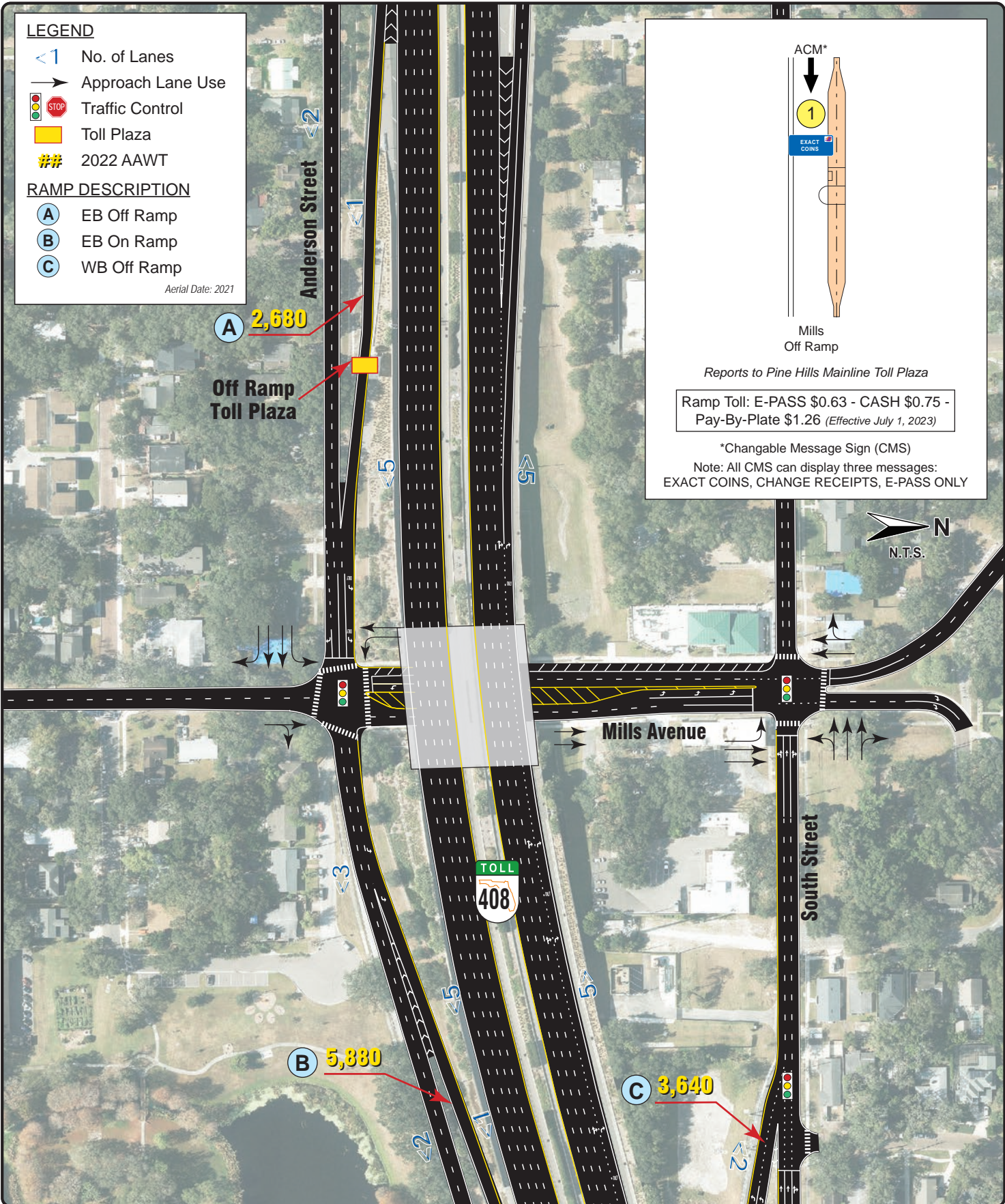

LEGEND

- <1 No. of Lanes
- ➔ Approach Lane Use
- 🚦 Traffic Control
- 🟡 Toll Plaza
- ## 2022 AAWT

RAMP DESCRIPTION

- A** EB Off Ramp
- B** WB On Ramp

Aerial Date: 2021

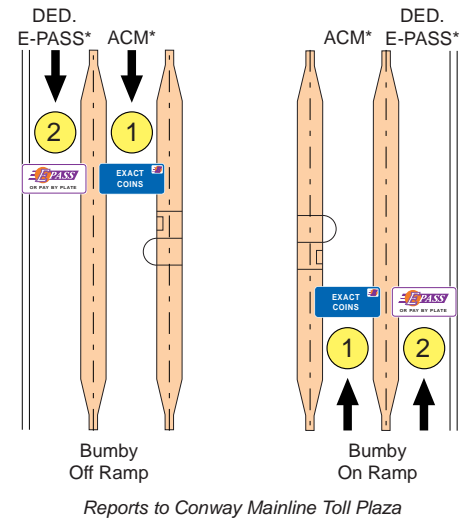

Ramp Toll: E-PASS \$0.63 - CASH \$0.75 - Pay-By-Plate \$1.26 (Effective July 1, 2023)

*Changable Message Sign (CMS)
 Note: All CMS can display three messages: EXACT COINS, CHANGE RECEIPTS, E-PASS ONLY

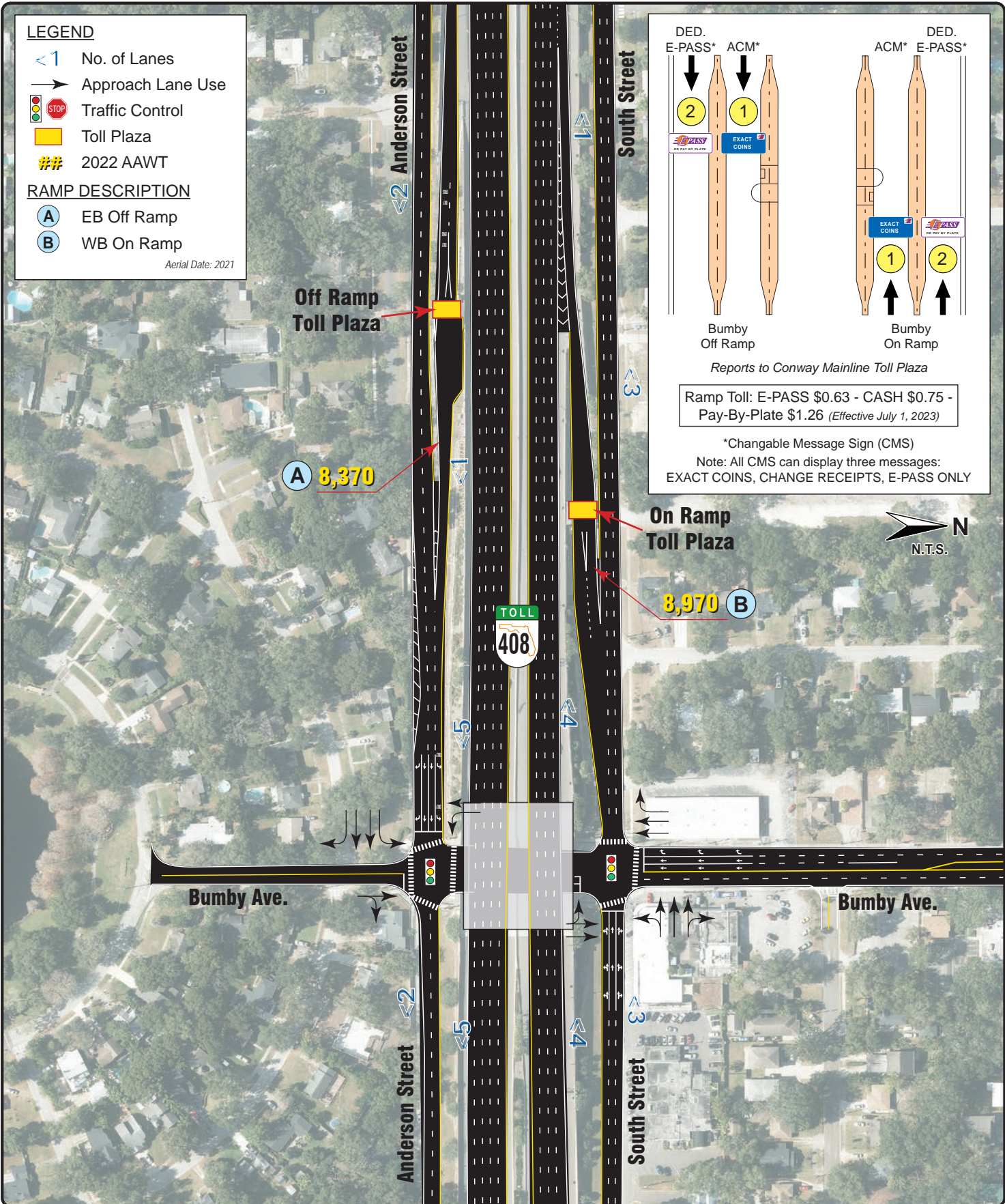



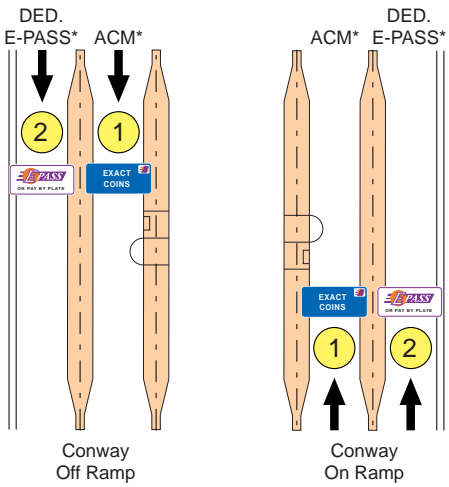

Reports to Conway Mainline Toll Plaza

Ramp Toll: E-PASS \$0.93 - CASH \$1.25 - Pay-By-Plate \$1.86 (Effective July 1, 2023)

*Changable Message Sign (CMS)

Note: All CMS can display three messages: EXACT COINS, CHANGE RECEIPTS, E-PASS ONLY

LEGEND

- <1 No. of Lanes
- Approach Lane Use
- STOP Traffic Control
- Yellow Box Toll Plaza
- ## 2022 AAWT

RAMP DESCRIPTION

- (A) EB Off Ramp
- (B) WB On Ramp

Aerial Date: 2021





Exit 13 - Conway Road
SR 408 (EAST-WEST EXPRESSWAY)

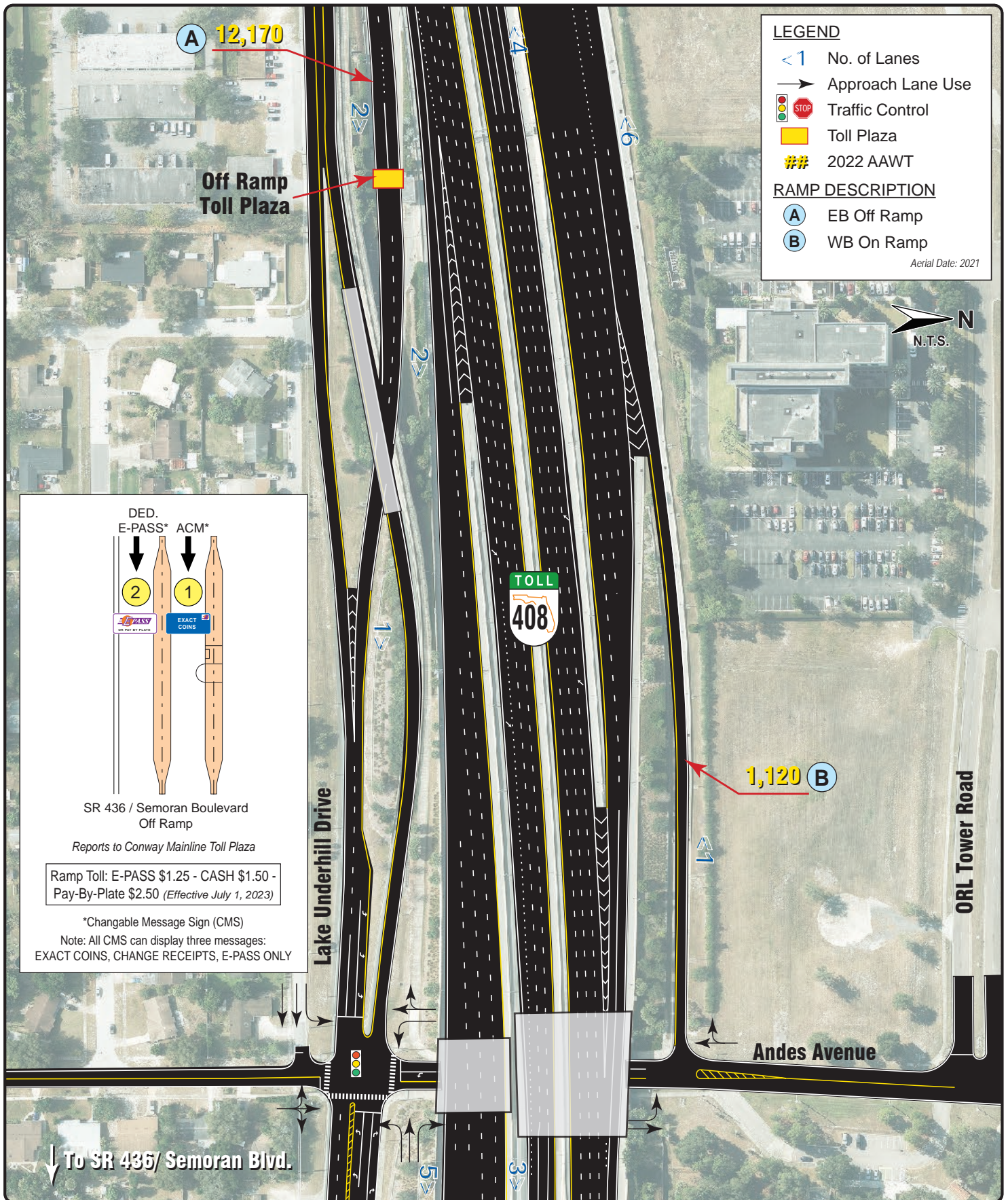

SECTION IV



LEGEND

- <1 No. of Lanes
- Approach Lane Use
-  Traffic Control
-  Toll Plaza
- ## 2022 AAWT

RAMP DESCRIPTION

-  WB On Ramp
-  WB On Loop Ramp
-  WB Off Ramp

Aerial Date: 2021

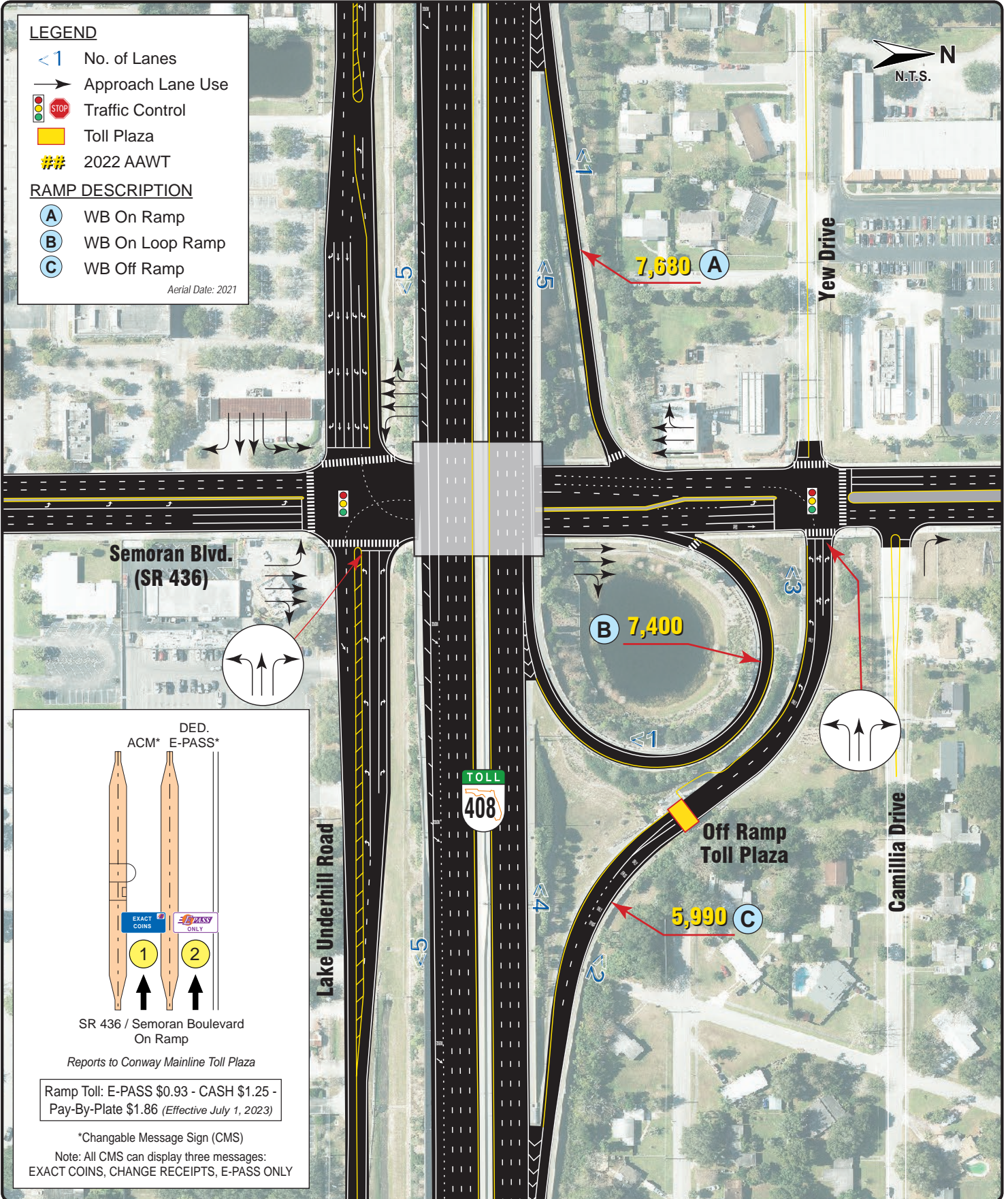

**Semoran Blvd.
(SR 436)**

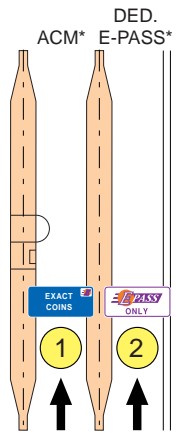
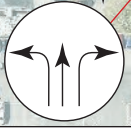

SR 436 / Semoran Boulevard
On Ramp

Reports to Conway Mainline Toll Plaza

Ramp Toll: E-PASS \$0.93 - CASH \$1.25 -
Pay-By-Plate \$1.86 (Effective July 1, 2023)

*Changable Message Sign (CMS)

Note: All CMS can display three messages:
EXACT COINS, CHANGE RECEIPTS, E-PASS ONLY



Exit 14 - Semoran Boulevard (SR 436)
SR 408 (EAST-WEST EXPRESSWAY)

SECTION IV

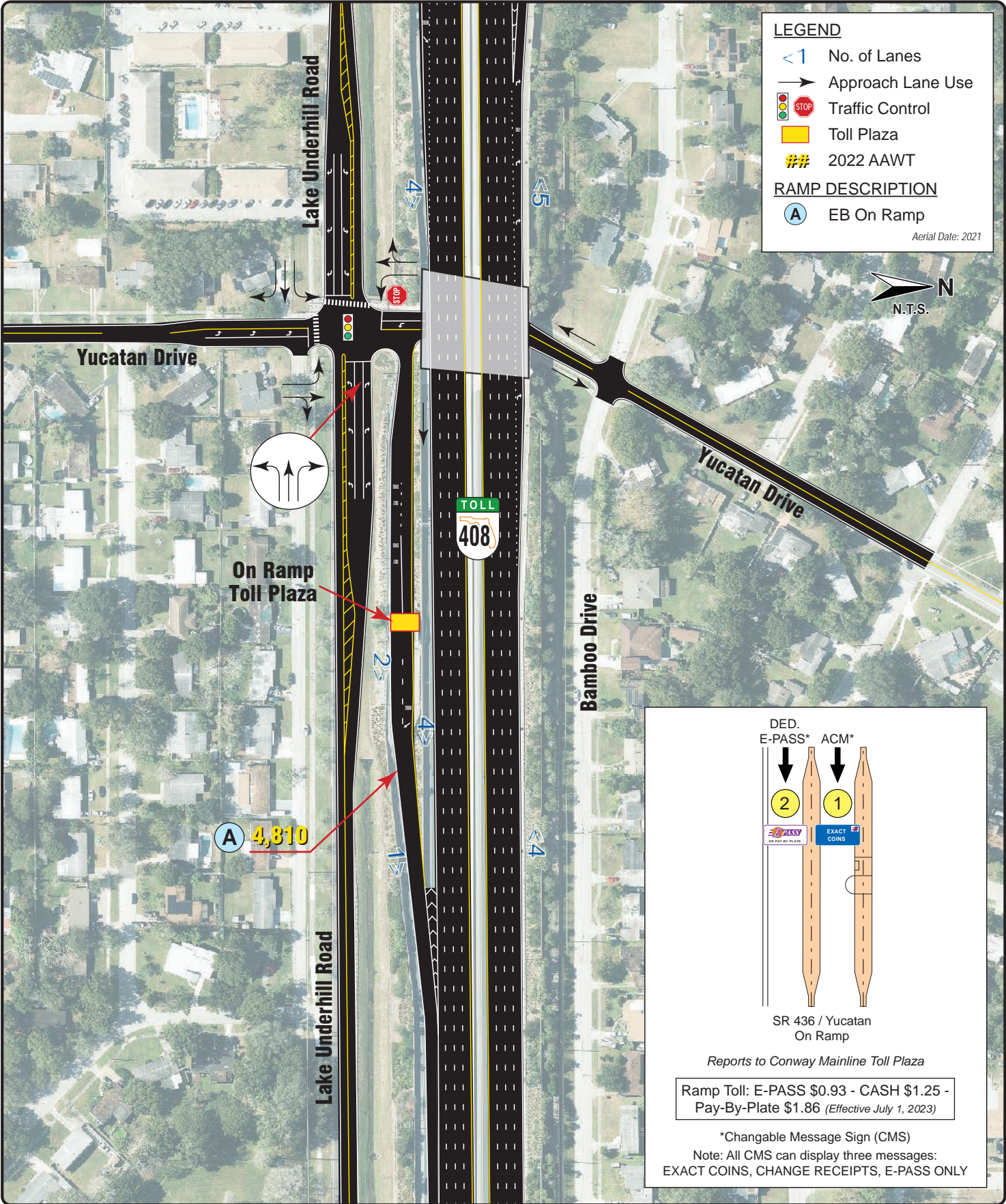

LEGEND

- <1 No. of Lanes
- Approach Lane Use
- STOP Traffic Control
- Yellow Box Toll Plaza
- ## 2022 AAWT

RAMP DESCRIPTION

- (A) EB On Ramp

Aerial Date: 2021

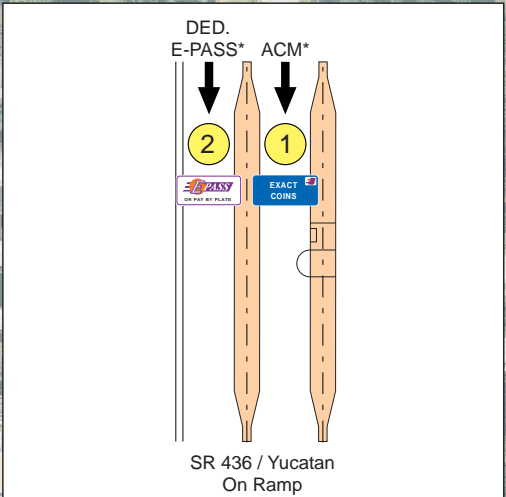

Reports to Conway Mainline Toll Plaza

Ramp Toll: E-PASS \$0.93 - CASH \$1.25 - Pay-By-Plate \$1.86 (Effective July 1, 2023)

*Changable Message Sign (CMS)
 Note: All CMS can display three messages: EXACT COINS, CHANGE RECEIPTS, E-PASS ONLY

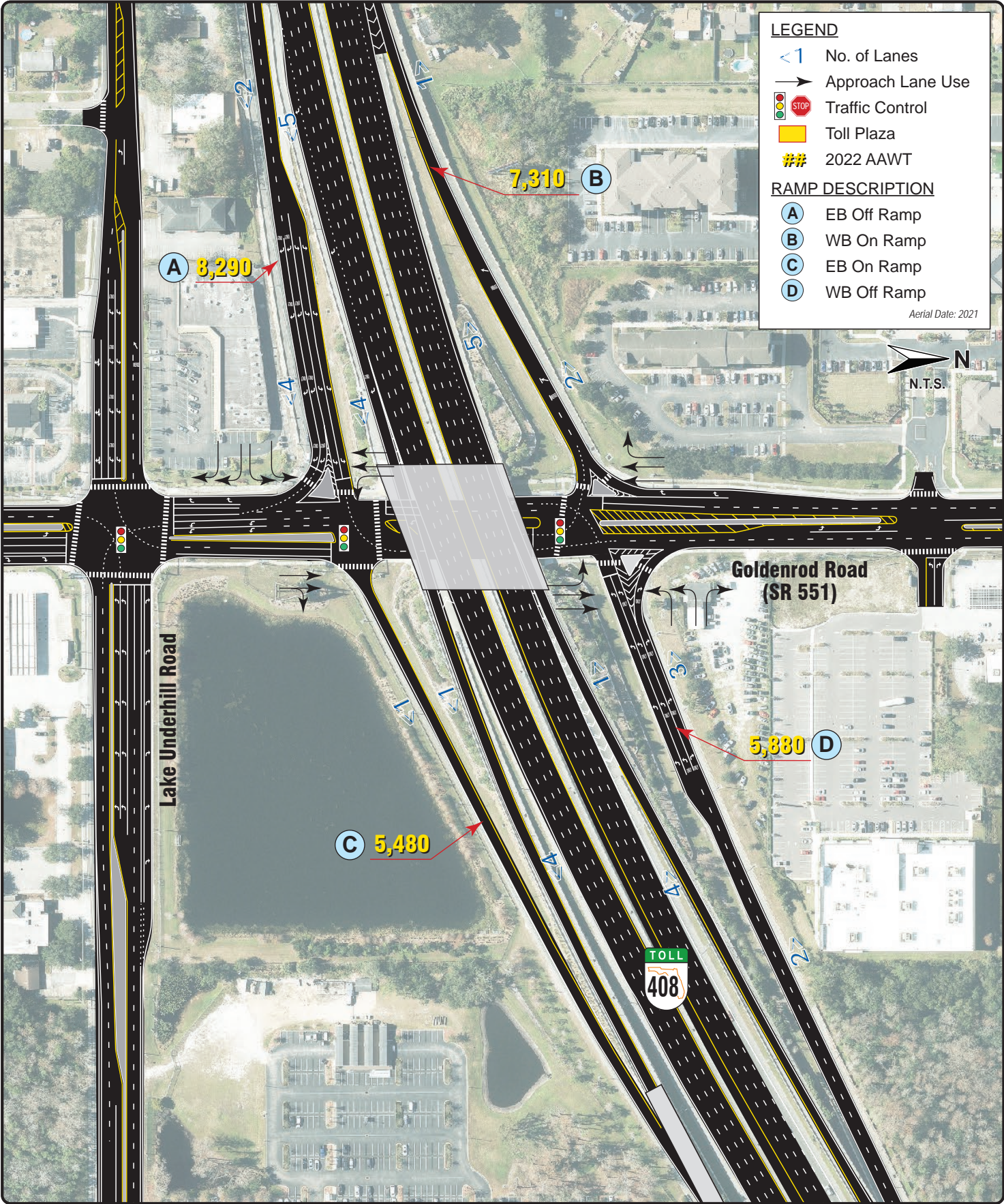

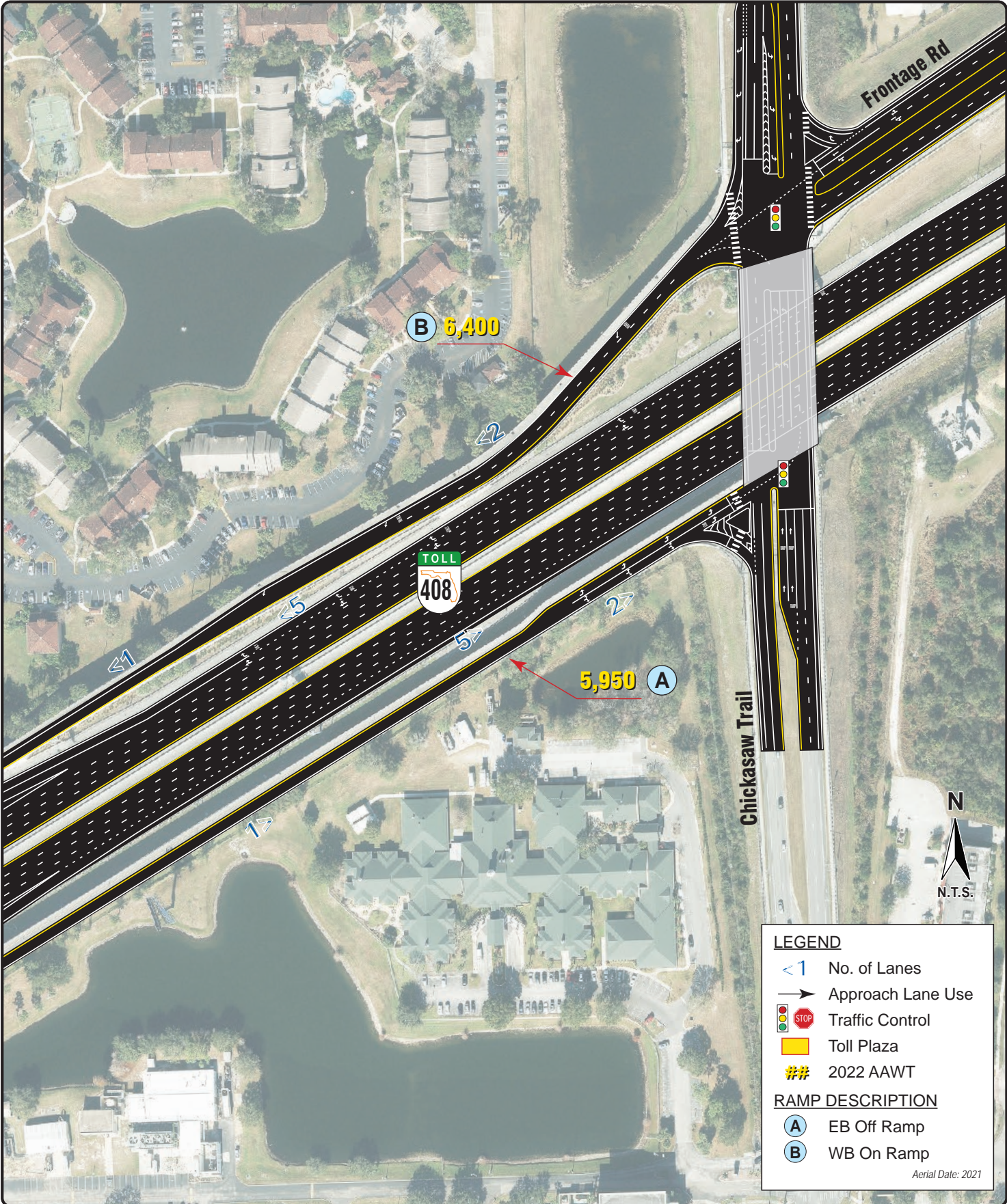

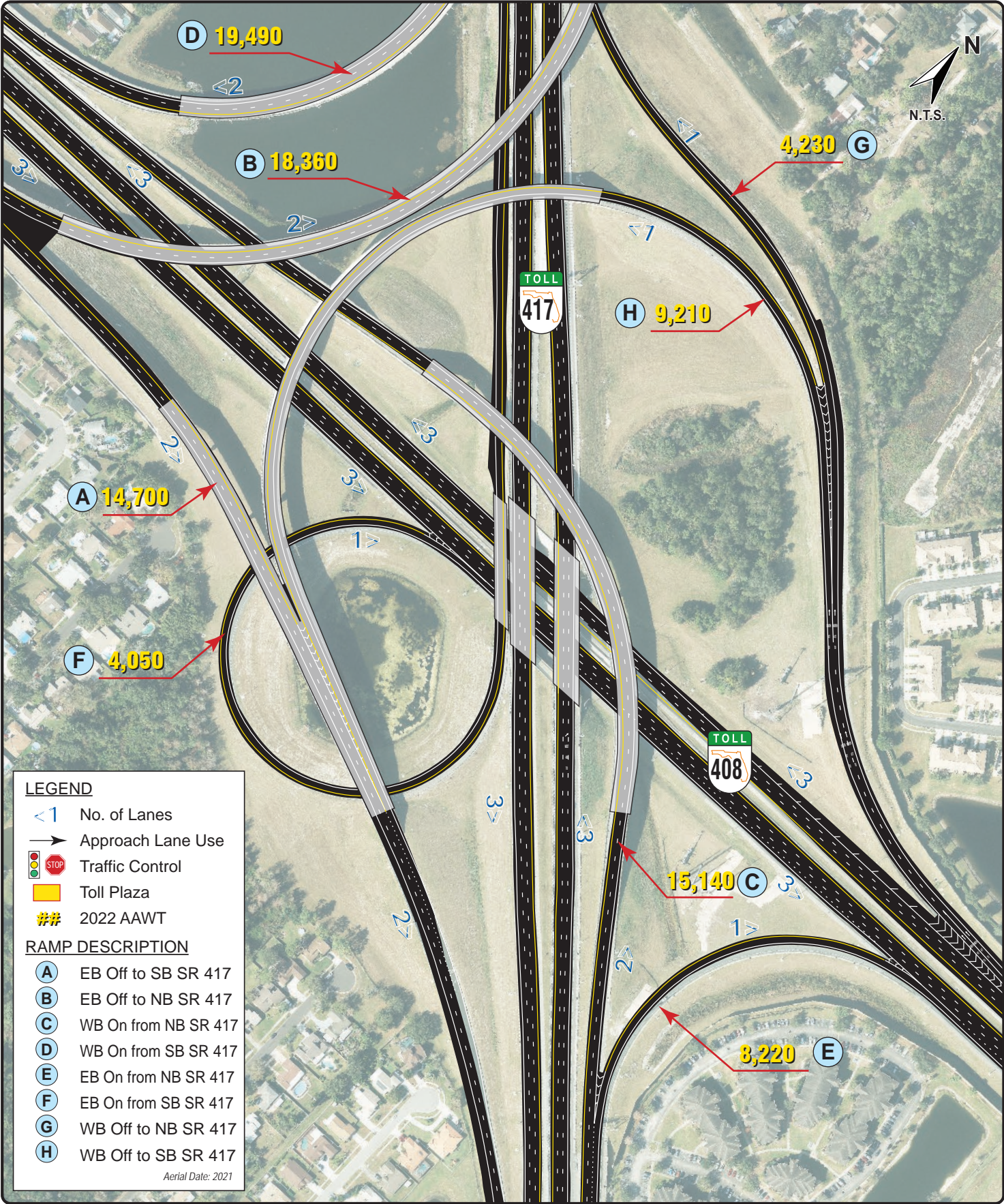



LEGEND

- <1 No. of Lanes
- Approach Lane Use
- Traffic Control
- Toll Plaza
- ## 2021 AAWT

RAMP DESCRIPTION

- A** EB Off Ramp
- B** WB On Ramp
- C** EB On Ramp
- D** WB Off Ramp

Aerial Date: 2021

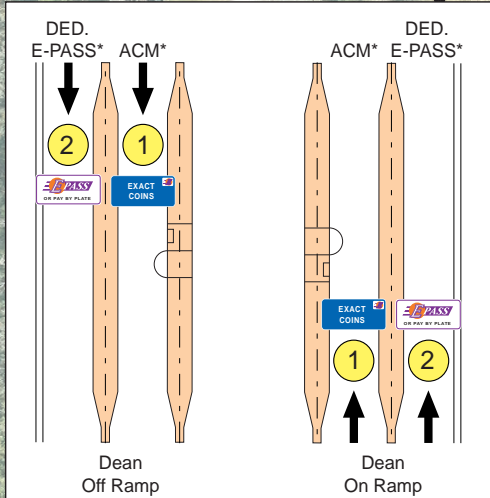
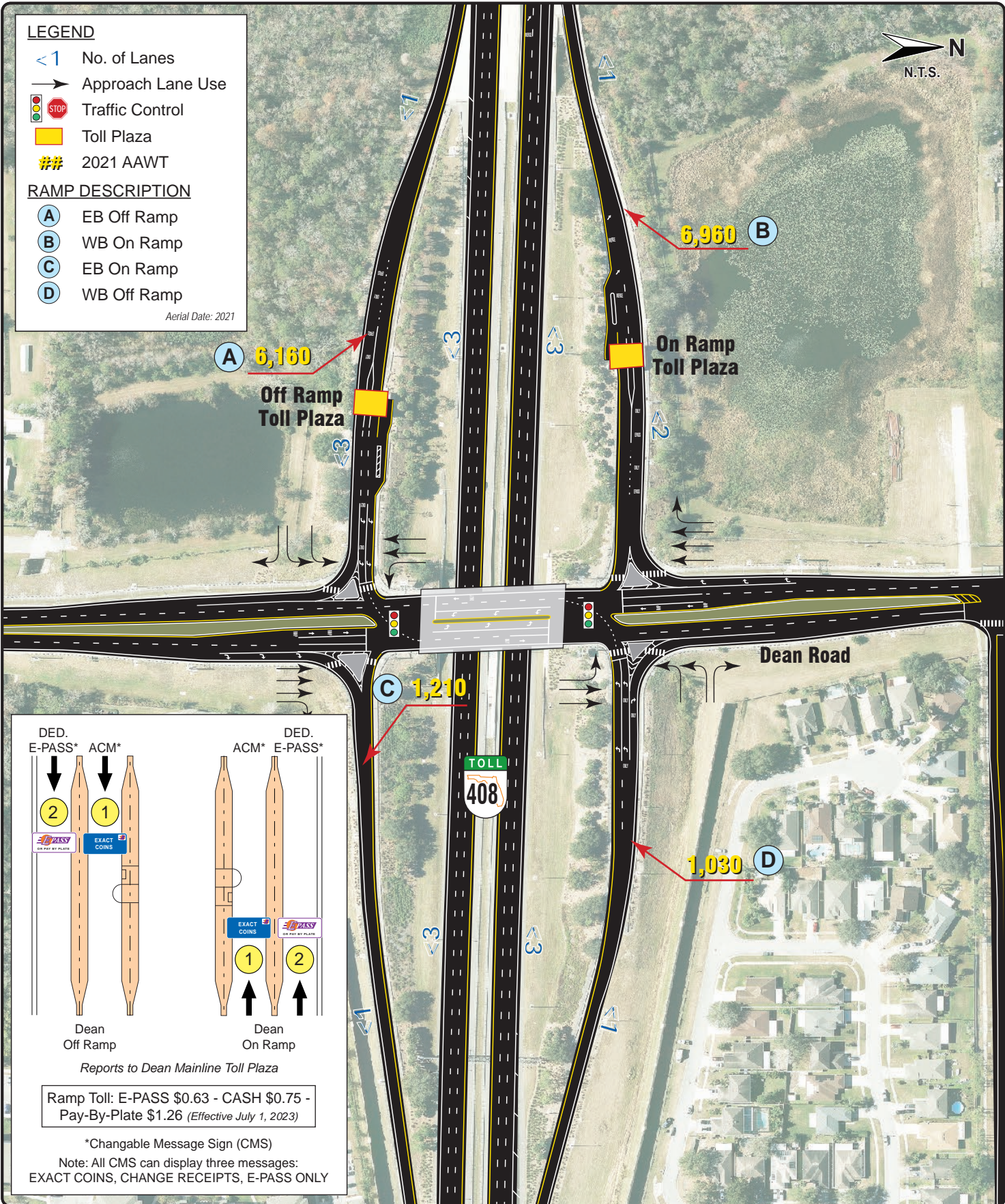

Reports to Dean Mainline Toll Plaza

Ramp Toll: E-PASS \$0.63 - CASH \$0.75 - Pay-By-Plate \$1.26 (Effective July 1, 2023)

*Changable Message Sign (CMS)

Note: All CMS can display three messages: EXACT COINS, CHANGE RECEIPTS, E-PASS ONLY



Exit 19 - Dean Road
SR 408 (EAST-WEST EXPRESSWAY)

SECTION IV

125

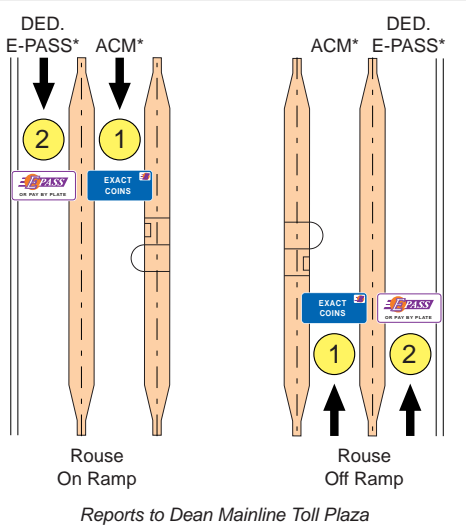

Ramp Toll: E-PASS \$0.63 - CASH \$.075 - Pay-By-Plate \$1.26 (Effective July 1, 2023)

*Changable Message Sign (CMS)

Note: All CMS can display three messages: EXACT COINS, CHANGE RECEIPTS, E-PASS ONLY

A 5,190

B 4,150

C 500

530 D

LEGEND

- <1 No. of Lanes
- Approach Lane Use
- STOP Traffic Control
- Yellow Box Toll Plaza
- ## 2022 AAWT

RAMP DESCRIPTION

- A** EB Off Ramp
- B** WB On Ramp
- C** EB On Ramp
- D** WB Off Ramp

Aerial Date: 2021

On Ramp Toll Plaza

Off Ramp Toll Plaza

TOLL 408



Exit 20 - Rouse Road
SR 408 (EAST-WEST EXPRESSWAY)

SECTION IV



LEGEND

- No. of Lanes
- Approach Lane Use
- Traffic Control
- Toll Plaza
- 2022 AAWT

RAMP DESCRIPTION

- EB Off Ramp
- WB On Ramp

Aerial Date: 2021



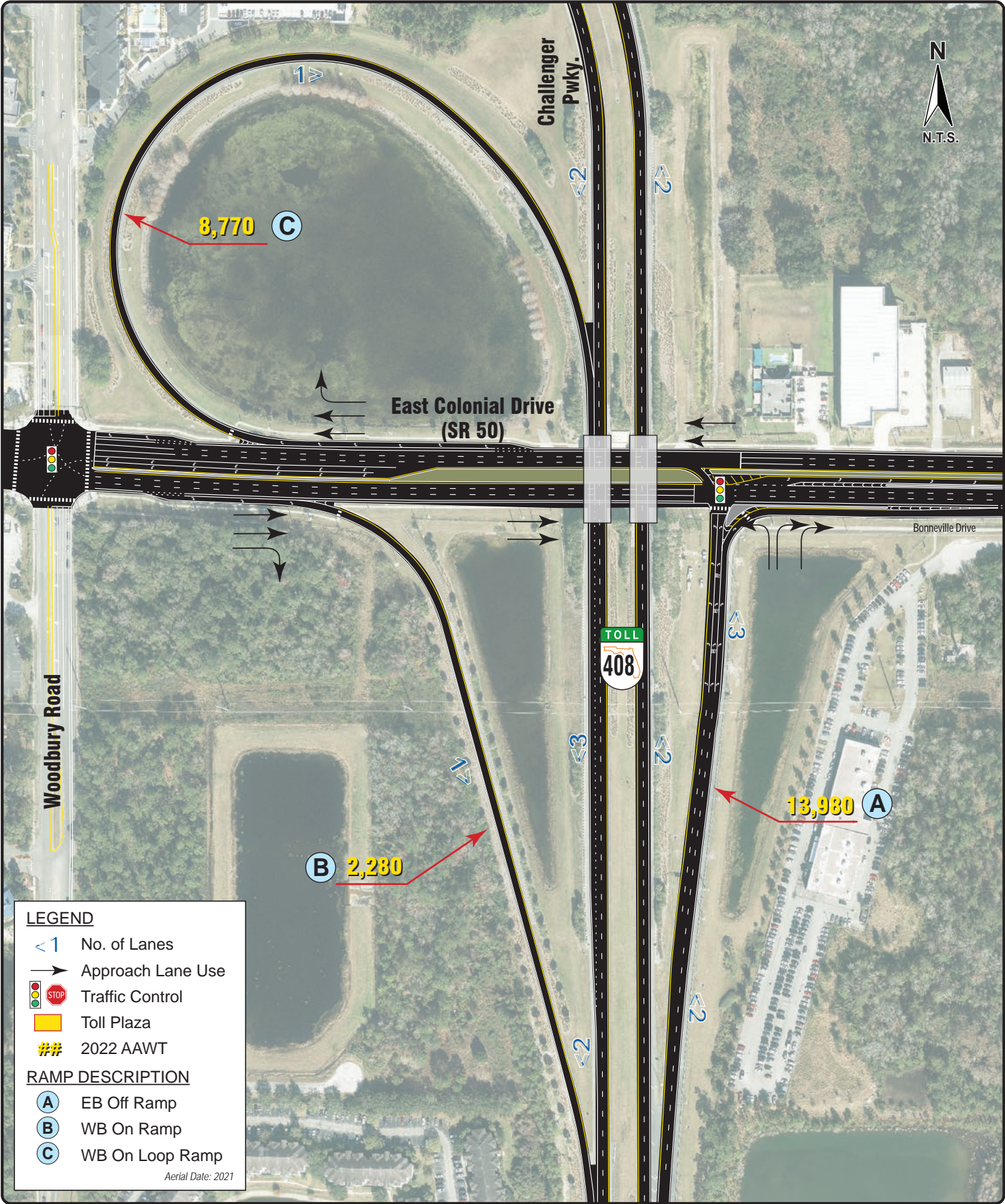

LEGEND

- < 1 No. of Lanes
- Approach Lane Use
- 🚦 Traffic Control
- 🟡 Toll Plaza
- ## 2022 AAWT

RAMP DESCRIPTION

- (A) EB Off Ramp
- (B) WB On Ramp
- (C) WB On Loop Ramp

Aerial Date: 2021

BEACHLINE EXPRESSWAY



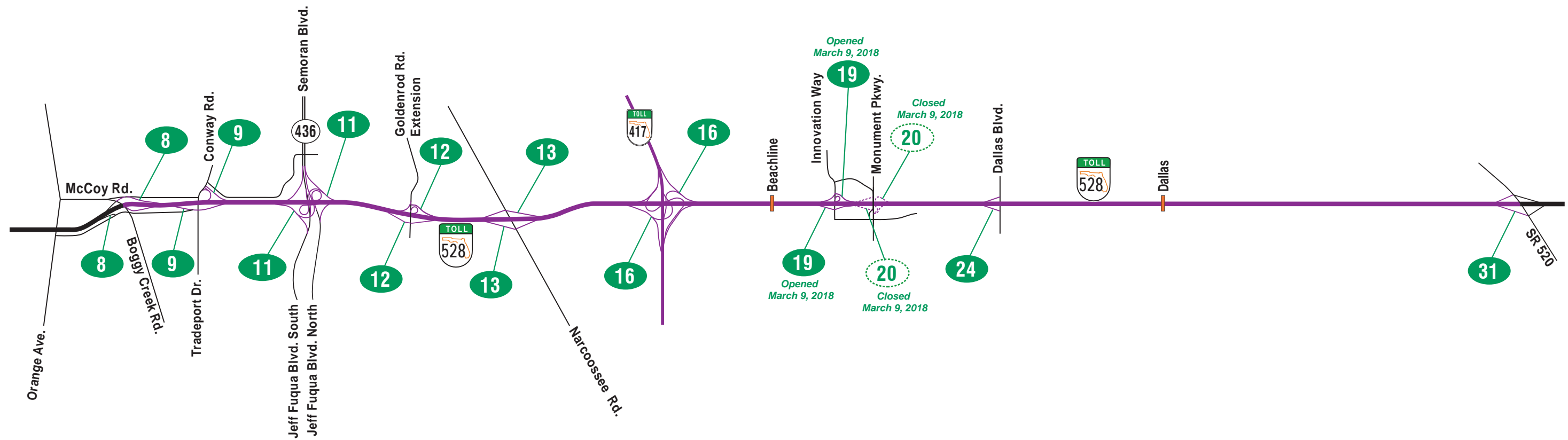

LEGEND

- Exit Number
- Existing SR 528
- Mainline Toll Plaza

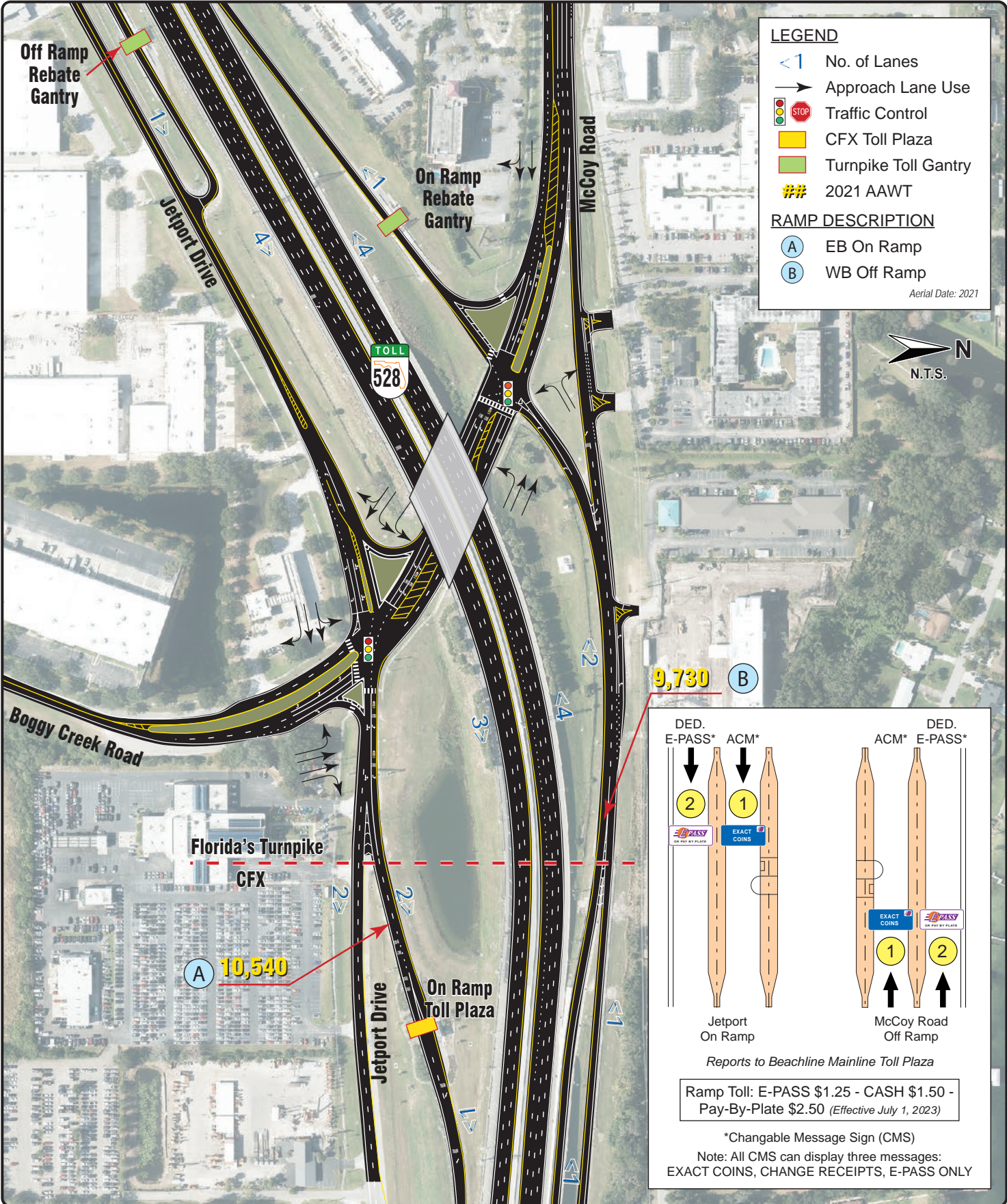

LEGEND

- <1 No. of Lanes
- Approach Lane Use
- 🚦 Traffic Control
- 🟡 CFX Toll Plaza
- 🟢 Turnpike Toll Gantry
- ## 2021 AAWT

RAMP DESCRIPTION

- (A) EB On Ramp
- (B) WB Off Ramp

Aerial Date: 2021



9,730 (B)

DED. E-PASS*	ACM*	DED. ACM*	E-PASS*
2	1	1	2

Jetport On Ramp

McCoy Road Off Ramp

Reports to Beachline Mainline Toll Plaza

Ramp Toll: E-PASS \$1.25 - CASH \$1.50 - Pay-By-Plate \$2.50 (Effective July 1, 2023)

*Changable Message Sign (CMS)

Note: All CMS can display three messages: EXACT COINS, CHANGE RECEIPTS, E-PASS ONLY

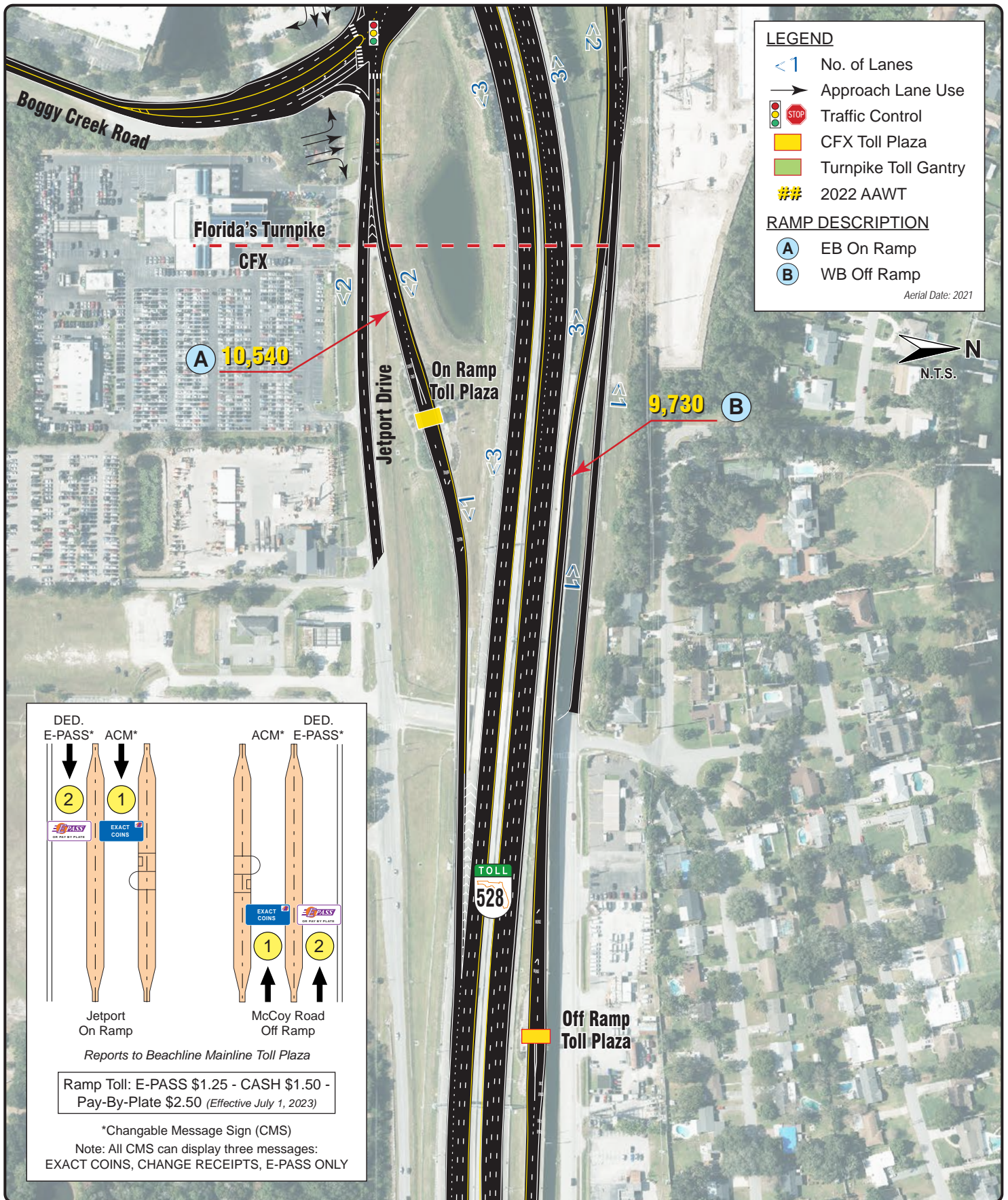

LEGEND

- <1 No. of Lanes
- Approach Lane Use
- STOP Traffic Control
- CFX Toll Plaza
- Turnpike Toll Gantry
- ## 2022 AAWT

RAMP DESCRIPTION

- (A) EB On Ramp
- (B) WB Off Ramp

Aerial Date: 2021



DED. E-PASS*	ACM*	DED. ACM*	DED. E-PASS*
↓	↓		
2	1	1	2
EXACT COINS	EXACT COINS	EXACT COINS	EXACT COINS
↑	↑	↑	↑
Jetport On Ramp		McCoy Road Off Ramp	
Reports to Beachline Mainline Toll Plaza			
Ramp Toll: E-PASS \$1.25 - CASH \$1.50 - Pay-By-Plate \$2.50 (Effective July 1, 2023)			
*Changable Message Sign (CMS)			
Note: All CMS can display three messages: EXACT COINS, CHANGE RECEIPTS, E-PASS ONLY			

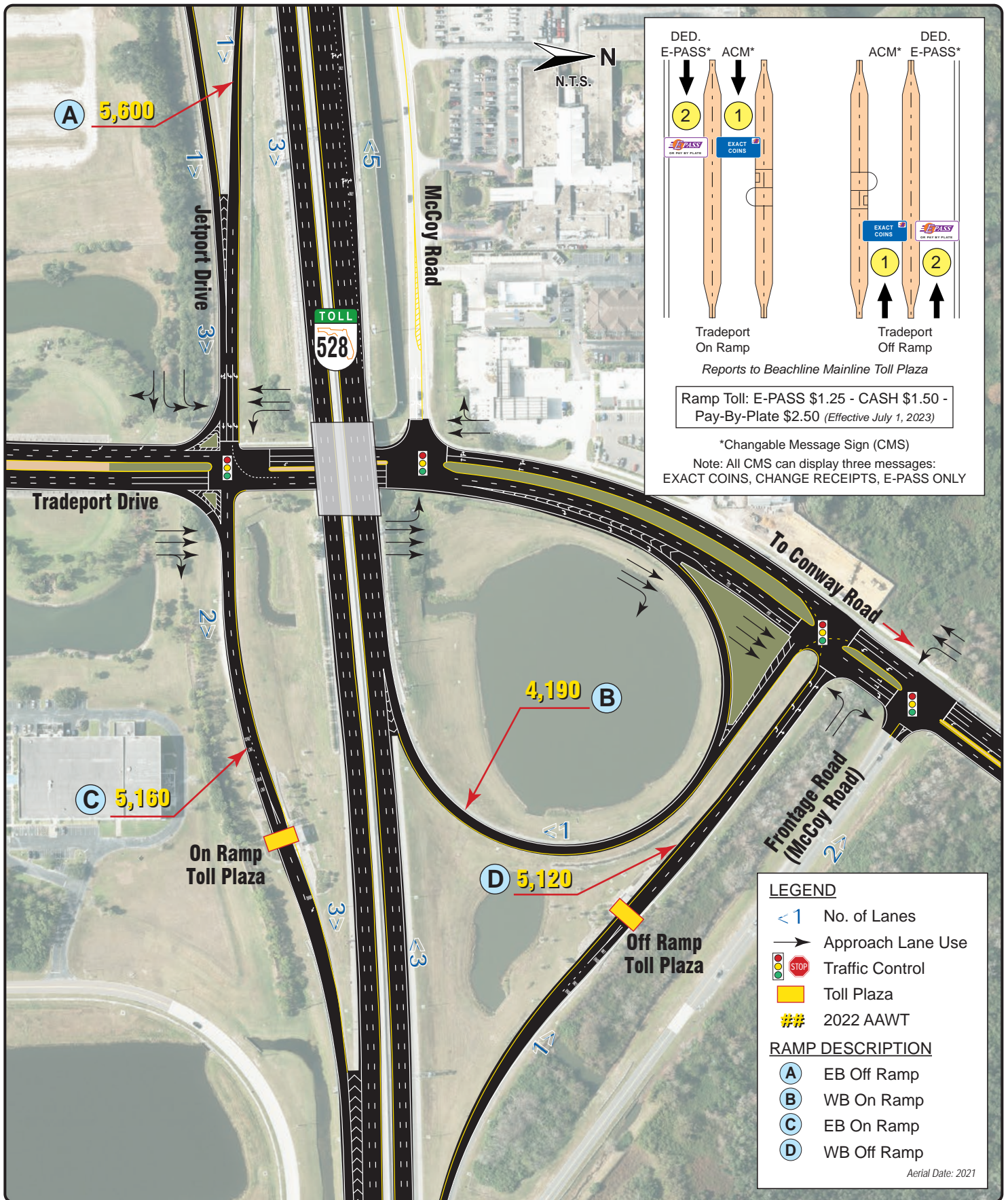

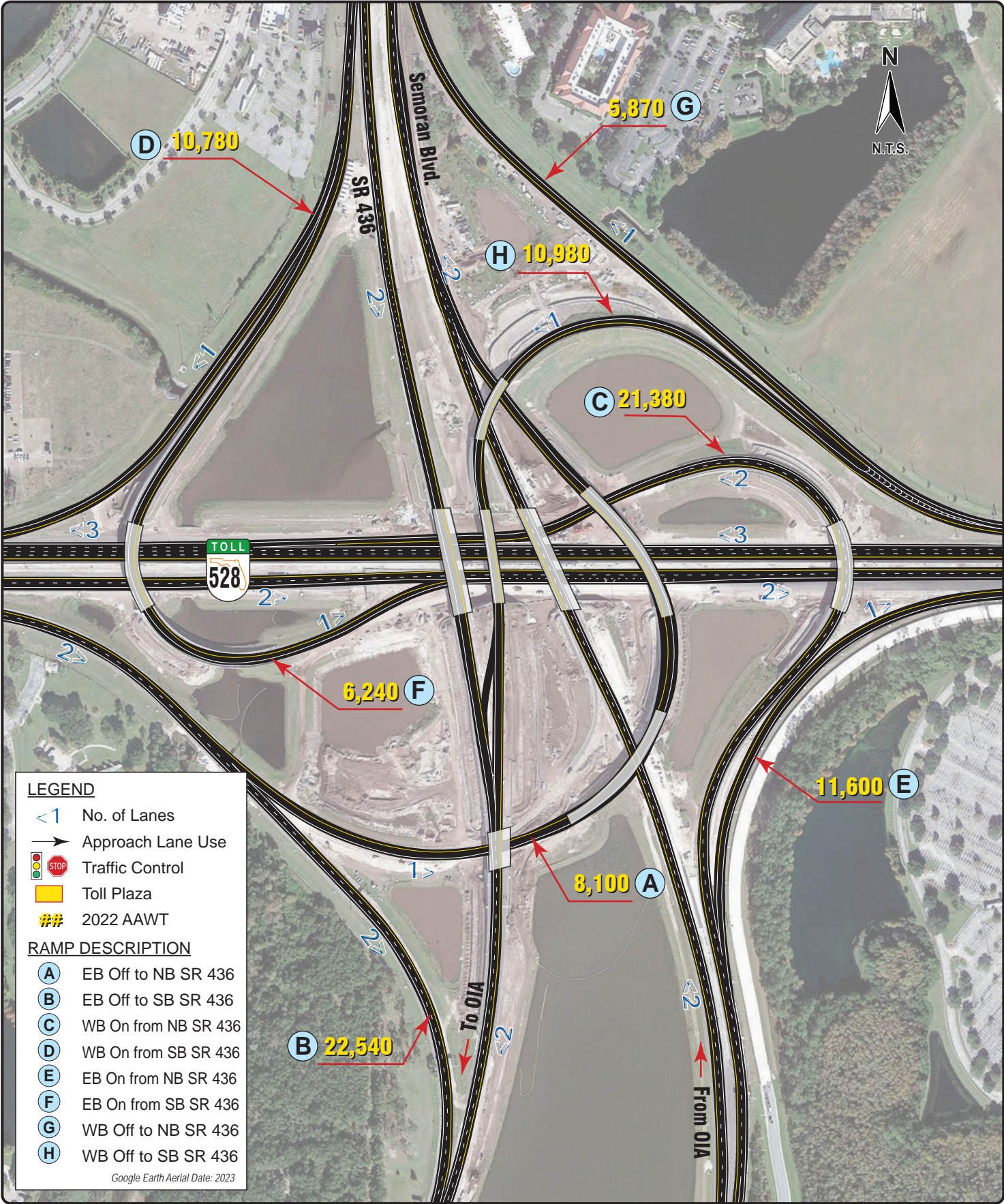

LEGEND

- <1 No. of Lanes
- ➔ Approach Lane Use
- 🚦🛑 Traffic Control
- 🟡 Toll Plaza
- ## 2022 AAWT

RAMP DESCRIPTION

- Ⓐ EB Off to NB SR 436
- Ⓑ EB Off to SB SR 436
- Ⓒ WB On from NB SR 436
- Ⓓ WB On from SB SR 436
- Ⓔ EB On from NB SR 436
- Ⓕ EB On from SB SR 436
- Ⓖ WB Off to NB SR 436
- Ⓗ WB Off to SB SR 436



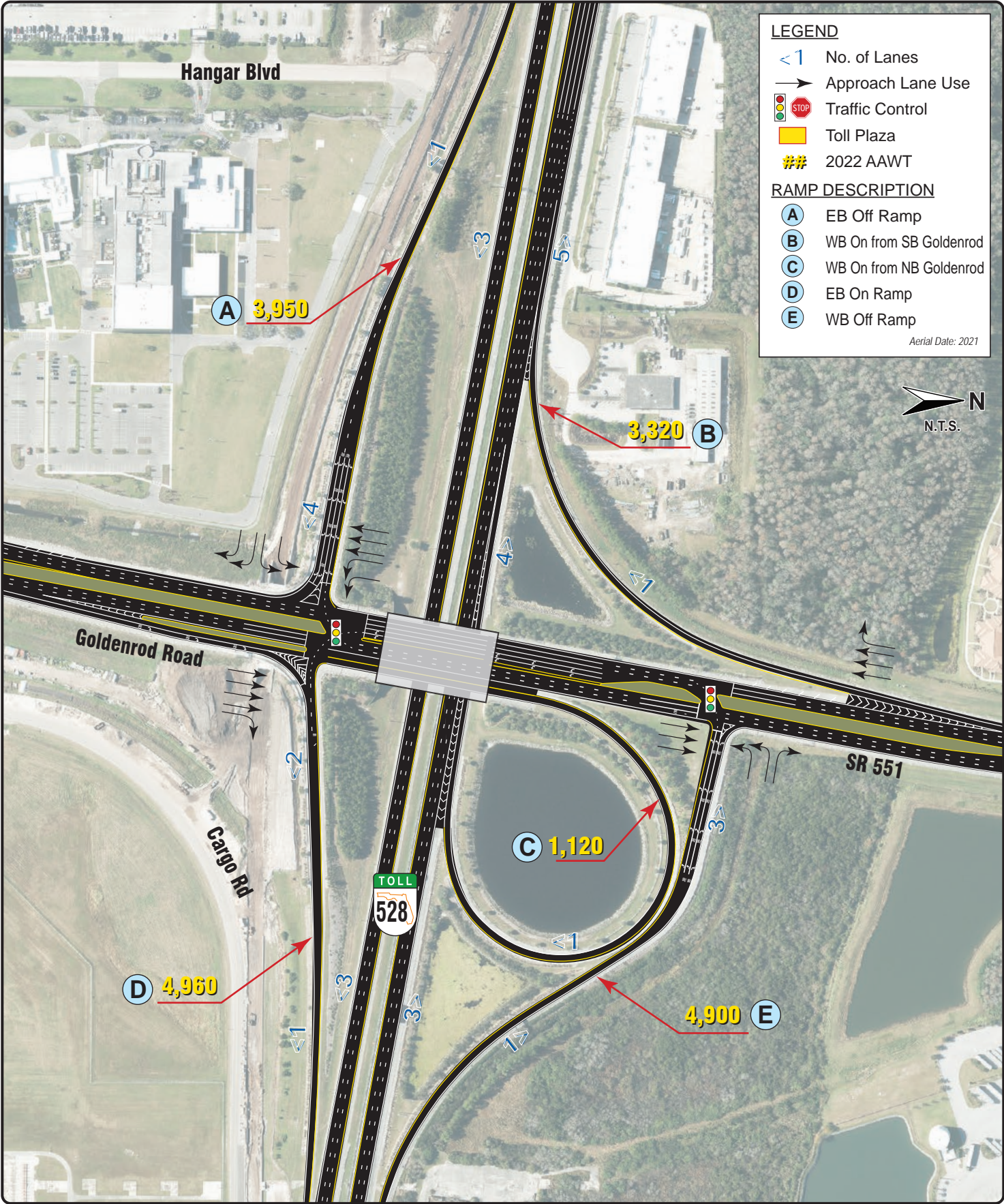

Google Earth Aerial Date: 2023



LEGEND

- < 1 No. of Lanes
- Approach Lane Use
-  Traffic Control
-  Toll Plaza
-  2022 AAWT

RAMP DESCRIPTION

-  EB Off Ramp
-  WB On Ramp
-  EB On Ramp
-  WB Off Ramp

Aerial Date: 2021

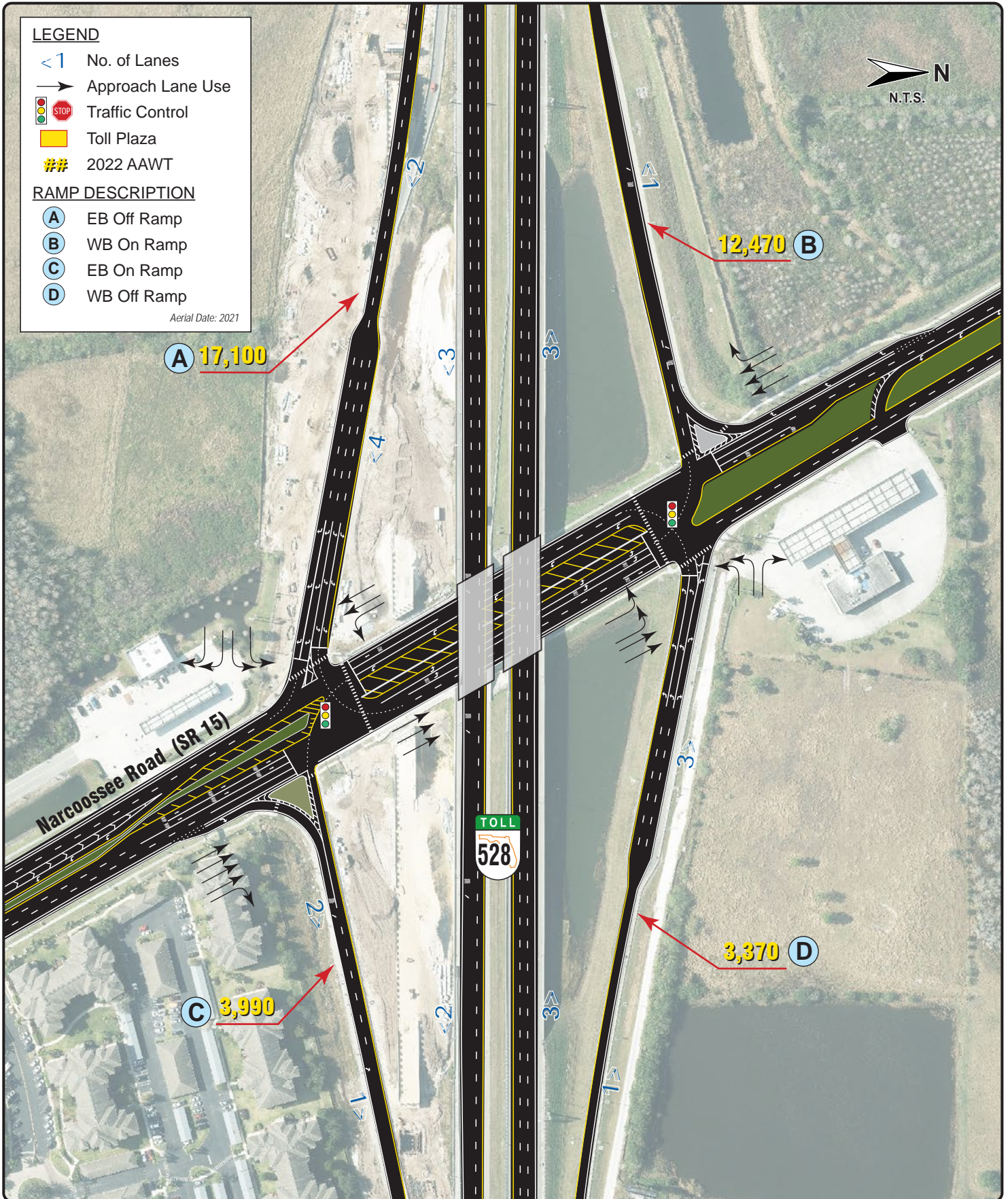

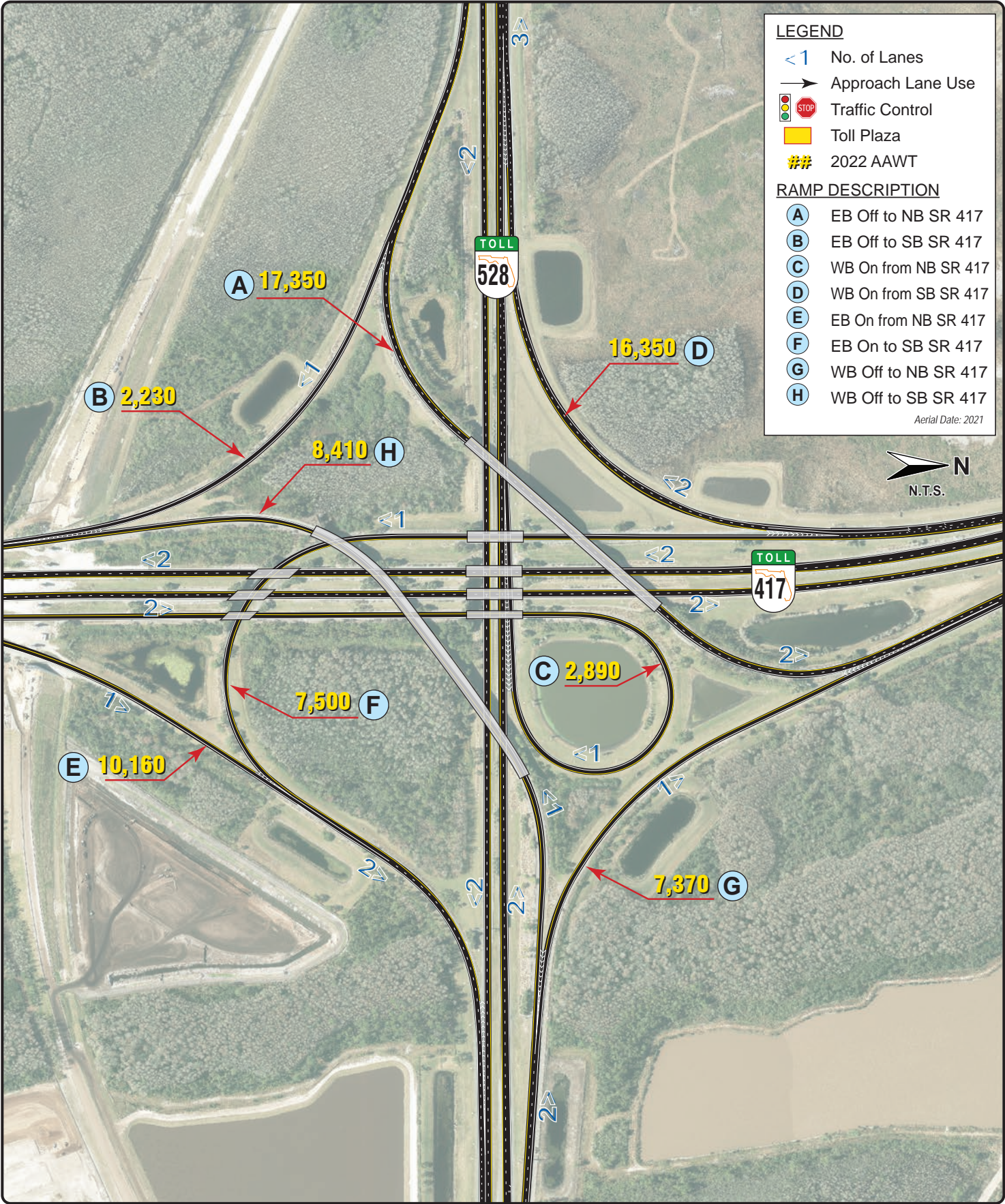

LEGEND

- <1 No. of Lanes
- Approach Lane Use
- Traffic Control
- Toll Plaza
- ##** 2022 AAWT

RAMP DESCRIPTION

- (A)** EB Off Ramp
- (B)** WB On Ramp
- (C)** WB On-Loop Ramp
- (D)** EB On Ramp
- (E)** WB Off Ramp

Aerial Date: 2021

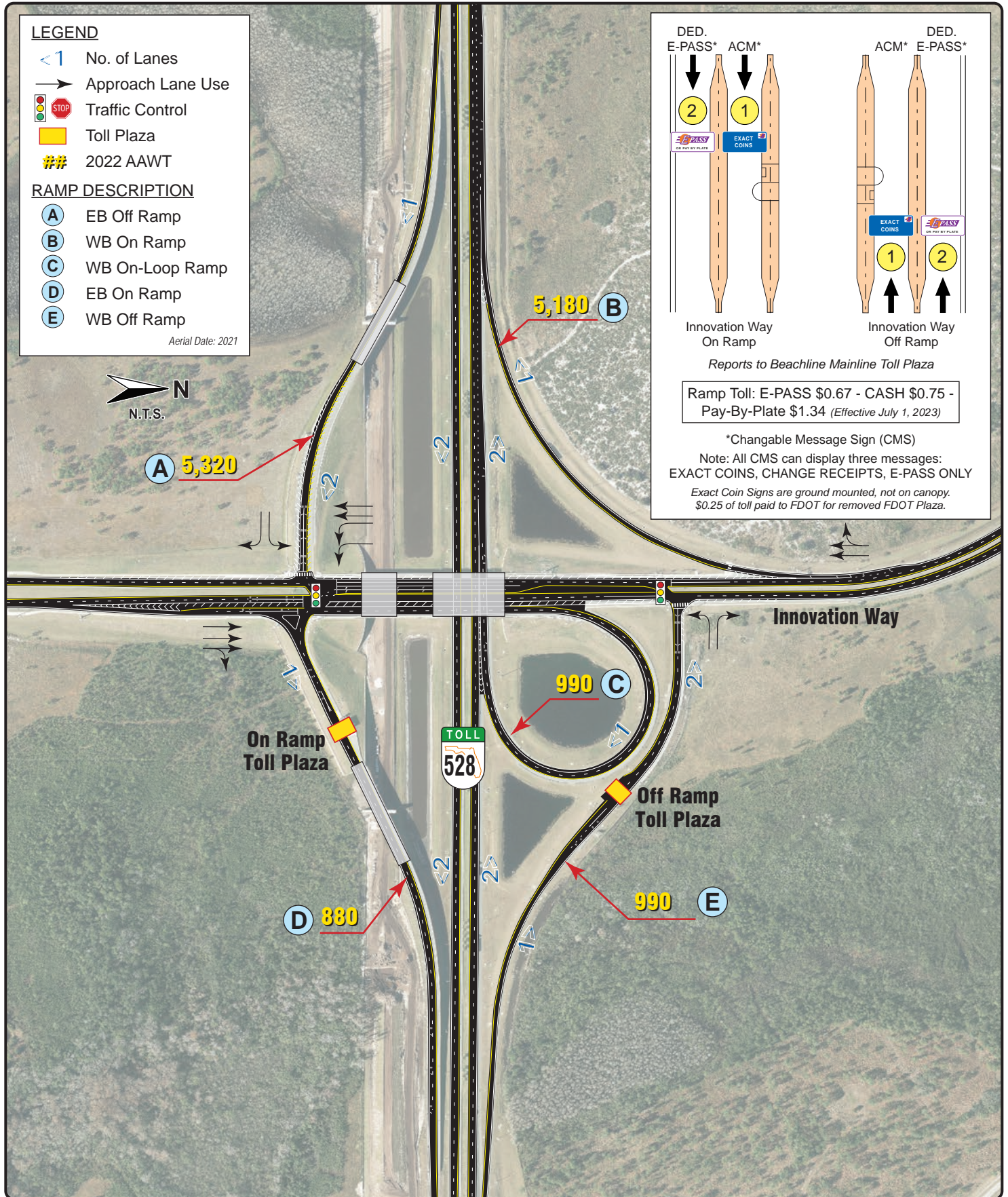

DED. E-PASS* ACM* DED. ACM* E-PASS*

Innovation Way On Ramp Innovation Way Off Ramp

Reports to Beachline Mainline Toll Plaza

Ramp Toll: E-PASS \$0.67 - CASH \$0.75 - Pay-By-Plate \$1.34 (Effective July 1, 2023)

*Changable Message Sign (CMS)
 Note: All CMS can display three messages: EXACT COINS, CHANGE RECEIPTS, E-PASS ONLY
 Exact Coin Signs are ground mounted, not on canopy.
 \$0.25 of toll paid to FDOT for removed FDOT Plaza.

LEGEND

- <1 No. of Lanes
- Approach Lane Use
- Traffic Control
- Toll Plaza
- ## 2022 AAWT



RAMP DESCRIPTION

- A** EB Off Ramp
- B** WB On Ramp

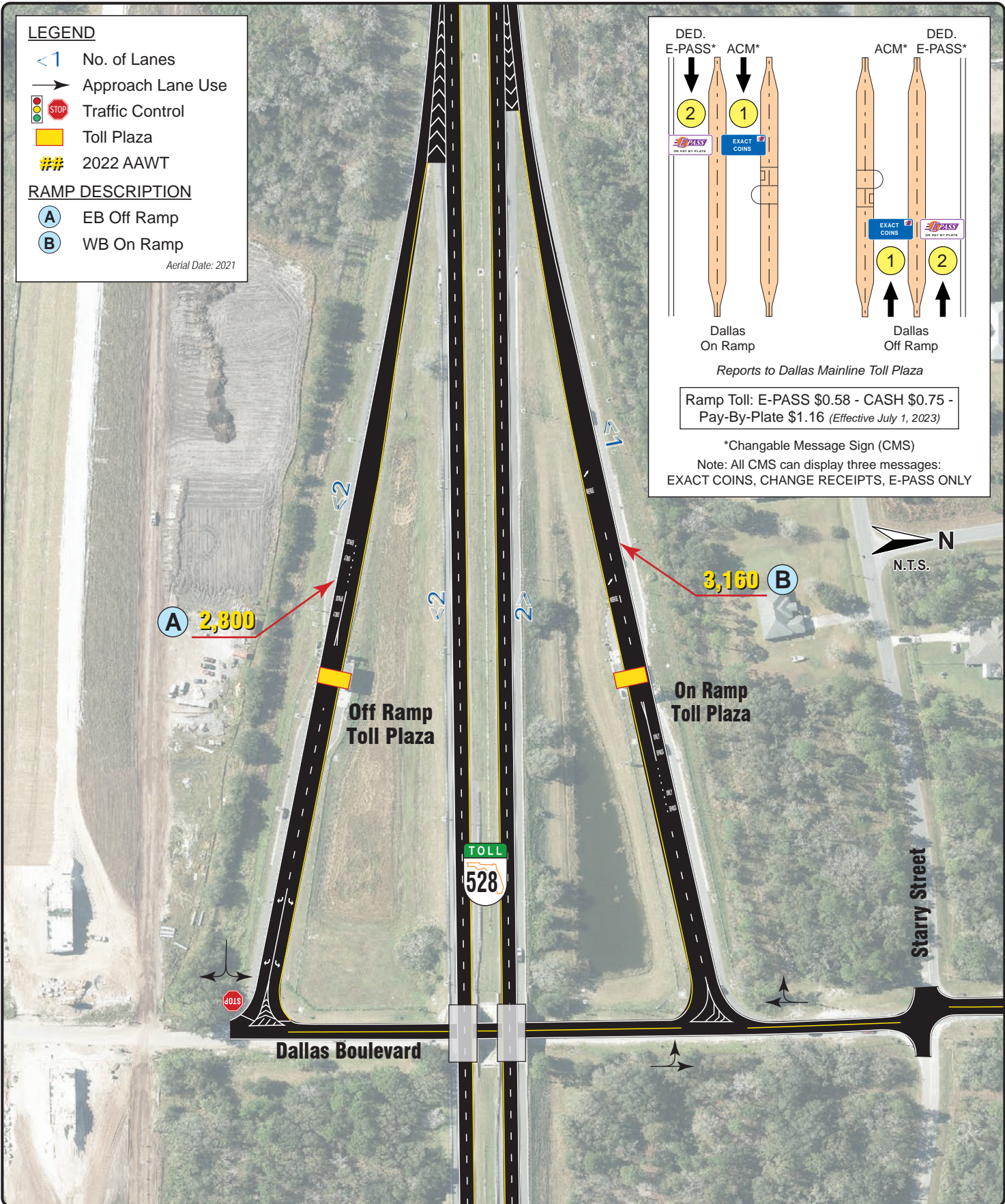
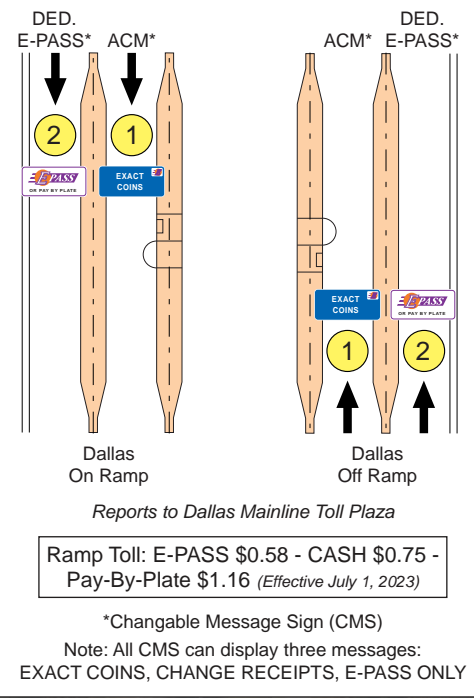

Aerial Date: 2021



LEGEND

- <1 No. of Lanes
- Approach Lane Use
-  Traffic Control
-  Toll Plaza
- ## 2022 AAWT

RAMP DESCRIPTION

-  EB Off Ramp
-  WB On Ramp

Aerial Date: 2021

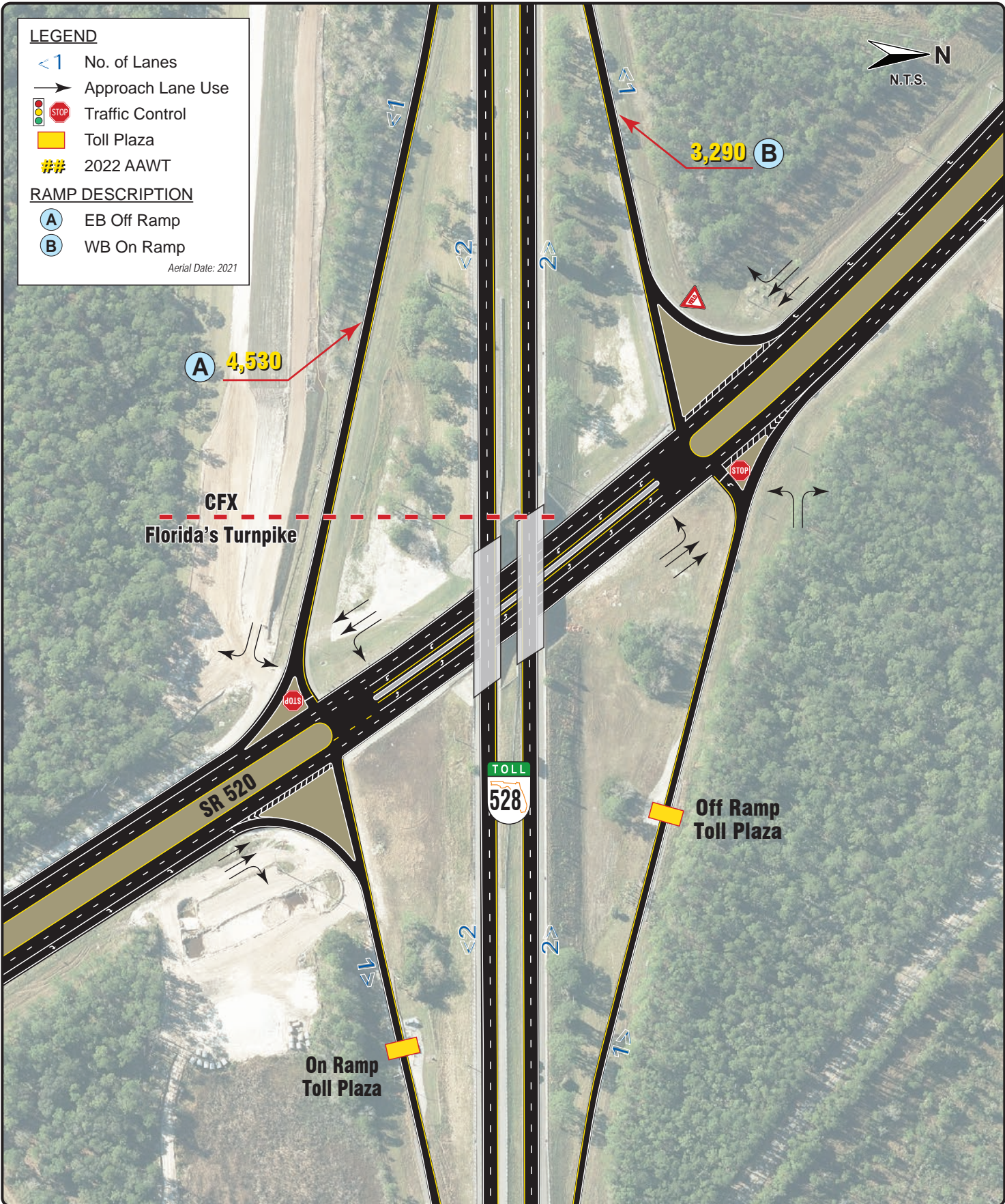

Exit 31 - SR 520
SR 528 (BEACHLINE EXPRESSWAY)

SECTION IV

140

CENTRAL FLORIDA GREENEWAY



2022 Traffic Data and Statistics Manual
CENTRAL FLORIDA EXPRESSWAY AUTHORITY



LEGEND

- Exit Number
- Existing SR 417
- Mainline Toll Plaza

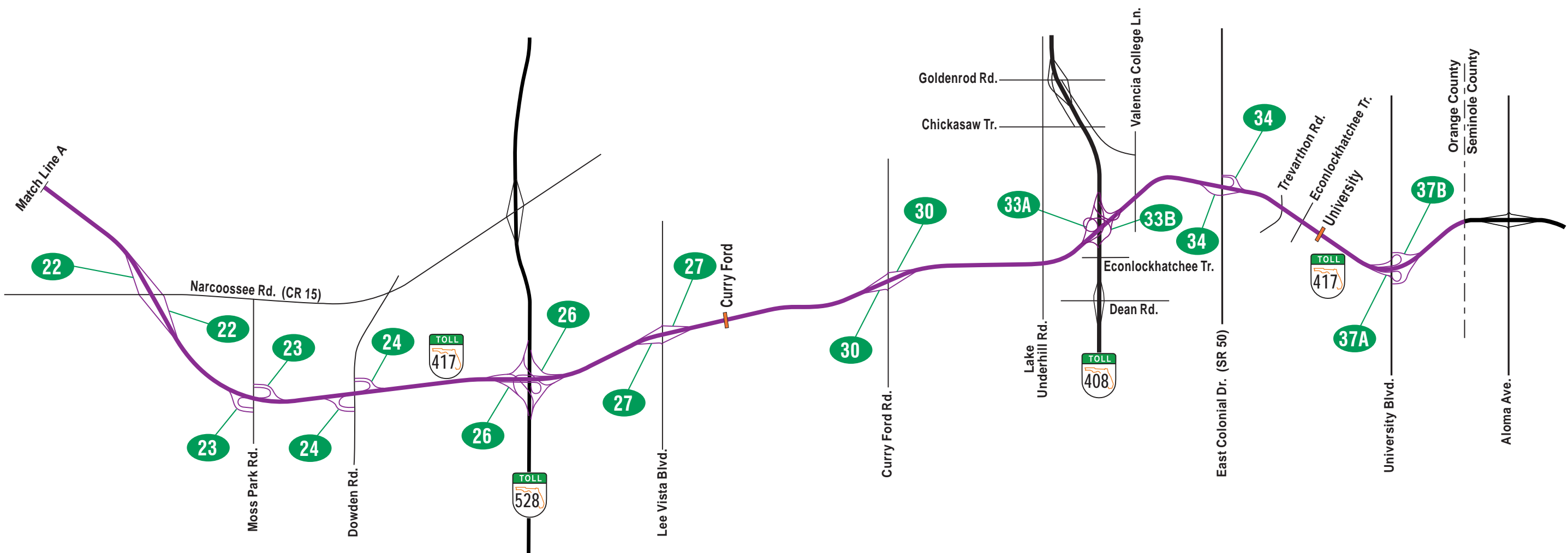

LEGEND

- Exit Number
- Existing SR 417
- Mainline Toll Plaza



Exit Numbers
SR 417 - CENTRAL FLORIDA GREENEWAY (2)

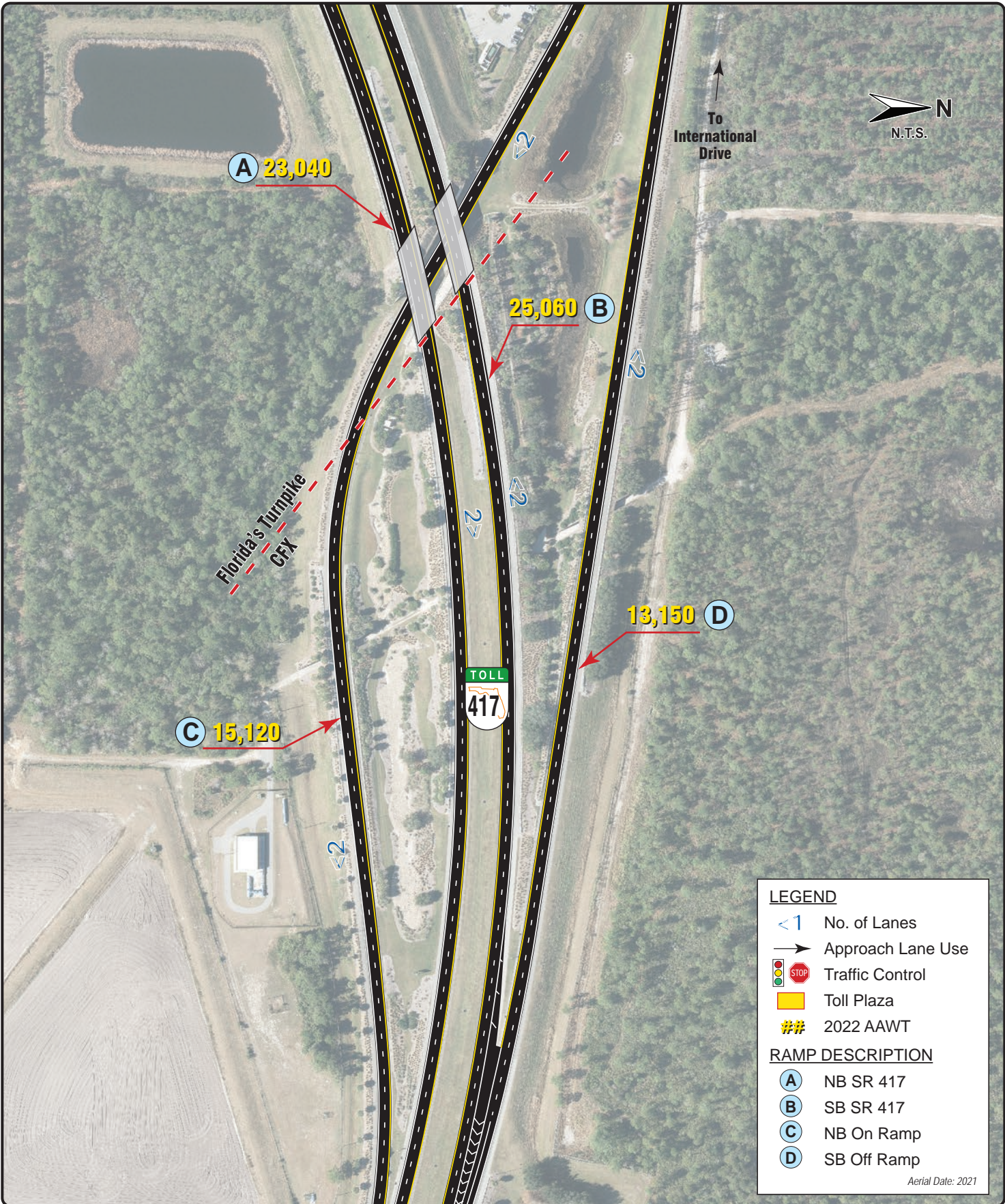

LEGEND

- <1 No. of Lanes
- Approach Lane Use
- 🚦 Traffic Control
- 🟡 Toll Plaza
- ## 2022 AAWT

RAMP DESCRIPTION

- (A) NB SR 417
- (B) SB SR 417
- (C) NB On Ramp
- (D) SB Off Ramp

Aerial Date: 2021

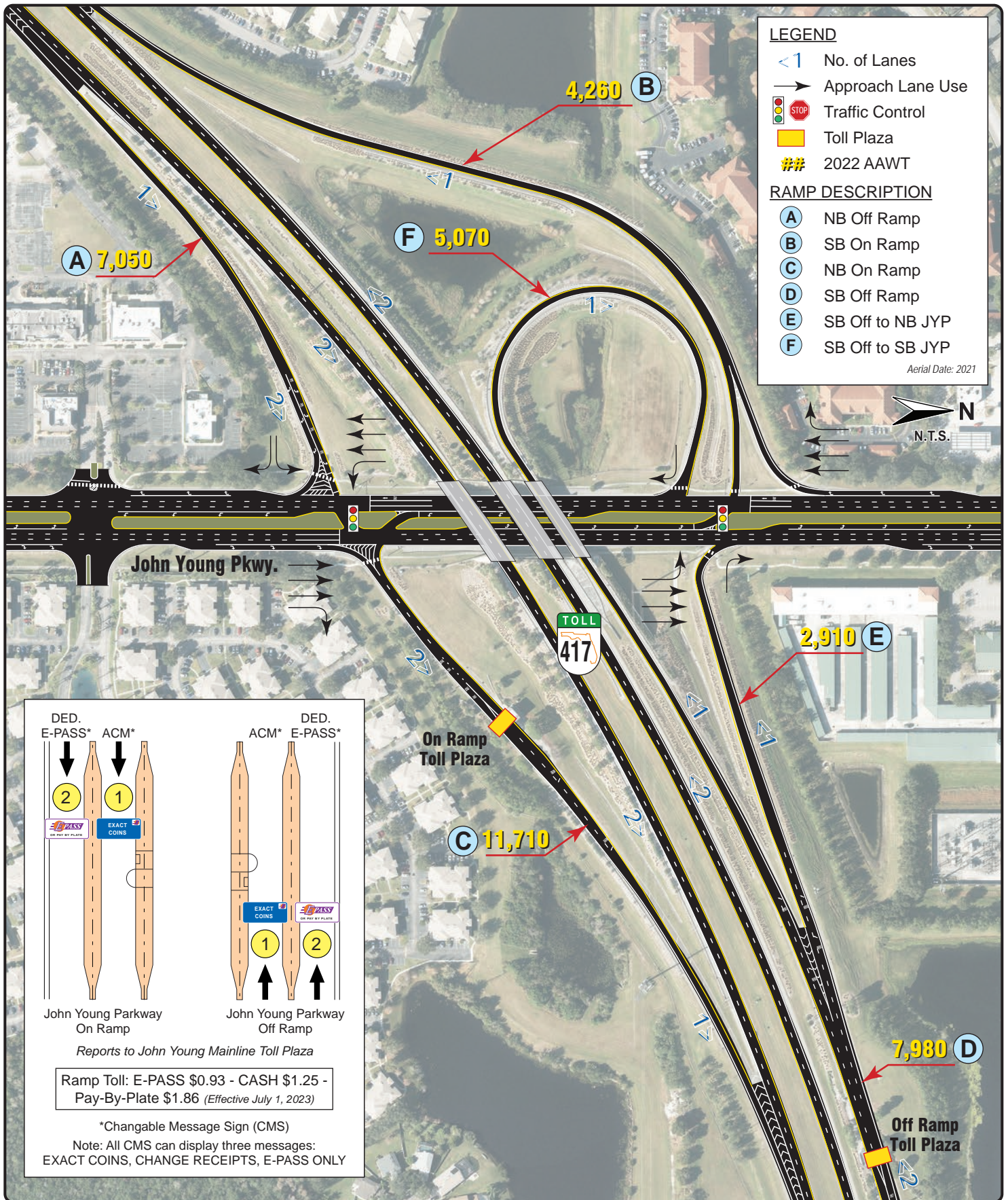

DED. E-PASS*	ACM*	DED. ACM*	E-PASS*
2	1	1	2
John Young Parkway On Ramp		John Young Parkway Off Ramp	
Reports to John Young Mainline Toll Plaza			
Ramp Toll: E-PASS \$0.93 - CASH \$1.25 - Pay-By-Plate \$1.86 (Effective July 1, 2023)			
*Changable Message Sign (CMS)			
Note: All CMS can display three messages: EXACT COINS, CHANGE RECEIPTS, E-PASS ONLY			

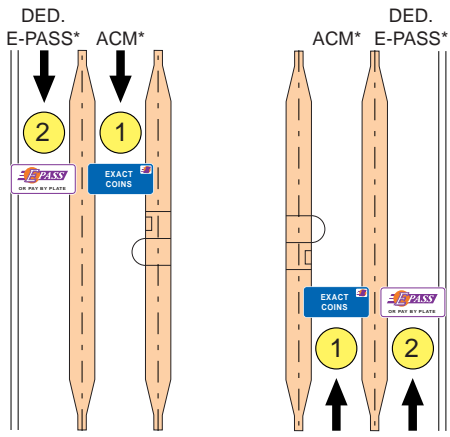

Orange Blossom Trail On Ramp
Orange Blossom Trail Off Ramp

Reports to John Young Mainline Toll Plaza

Ramp Toll: E-PASS \$0.63 - CASH \$0.75 - Pay-By-Plate \$1.25 (Effective July 1, 2023)

*Changable Message Sign (CMS)

Note: All CMS can display three messages: EXACT COINS, CHANGE RECEIPTS, E-PASS ONLY



LEGEND

- <1 No. of Lanes
- Approach Lane Use
- STOP Traffic Control
- Toll Plaza
- ## 2022 AAWT

RAMP DESCRIPTION

- (A) NB Off Ramp
- (B) SB On Ramp
- (C) NB On Ramp
- (D) SB Off Ramp

Aerial Date: 2021

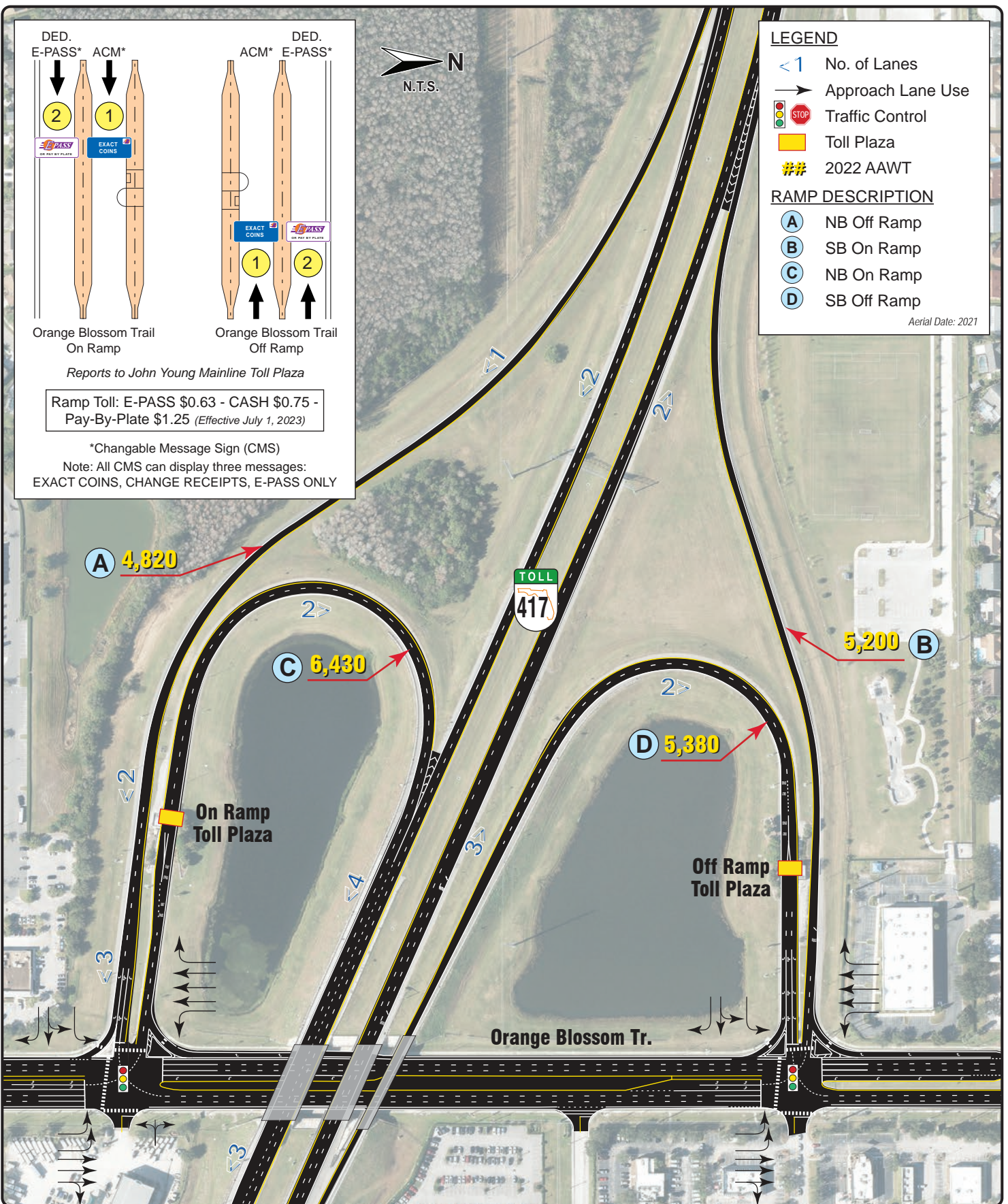



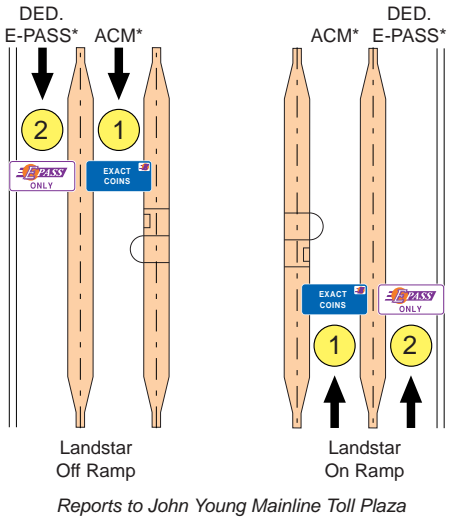

Ramp Toll: E-PASS \$0.50 - CASH \$0.50 - Pay-By-Plate \$1.00 (Effective July 1, 2023)

*Changable Message Sign (CMS)

Note: All CMS can display three messages: EXACT COINS, CHANGE RECEIPTS, E-PASS ONLY

Off Ramp Toll Plaza

On Ramp Toll Plaza

7,430 A

10,550 B

4,240 C

4,160 D

Landstar Blvd.



LEGEND

- <1 No. of Lanes
- ➔ Approach Lane Use
- 🚦 Traffic Control
- 🟡 Toll Plaza
- ## 2022 AAWT

RAMP DESCRIPTION

- A NB Off Ramp
- B SB On Ramp
- C NB On Ramp
- D SB Off Ramp

Aerial Date: 2021



Exit 14 - Landstar Boulevard
SR 417 (CENTRAL FLORIDA GREENEWAY)

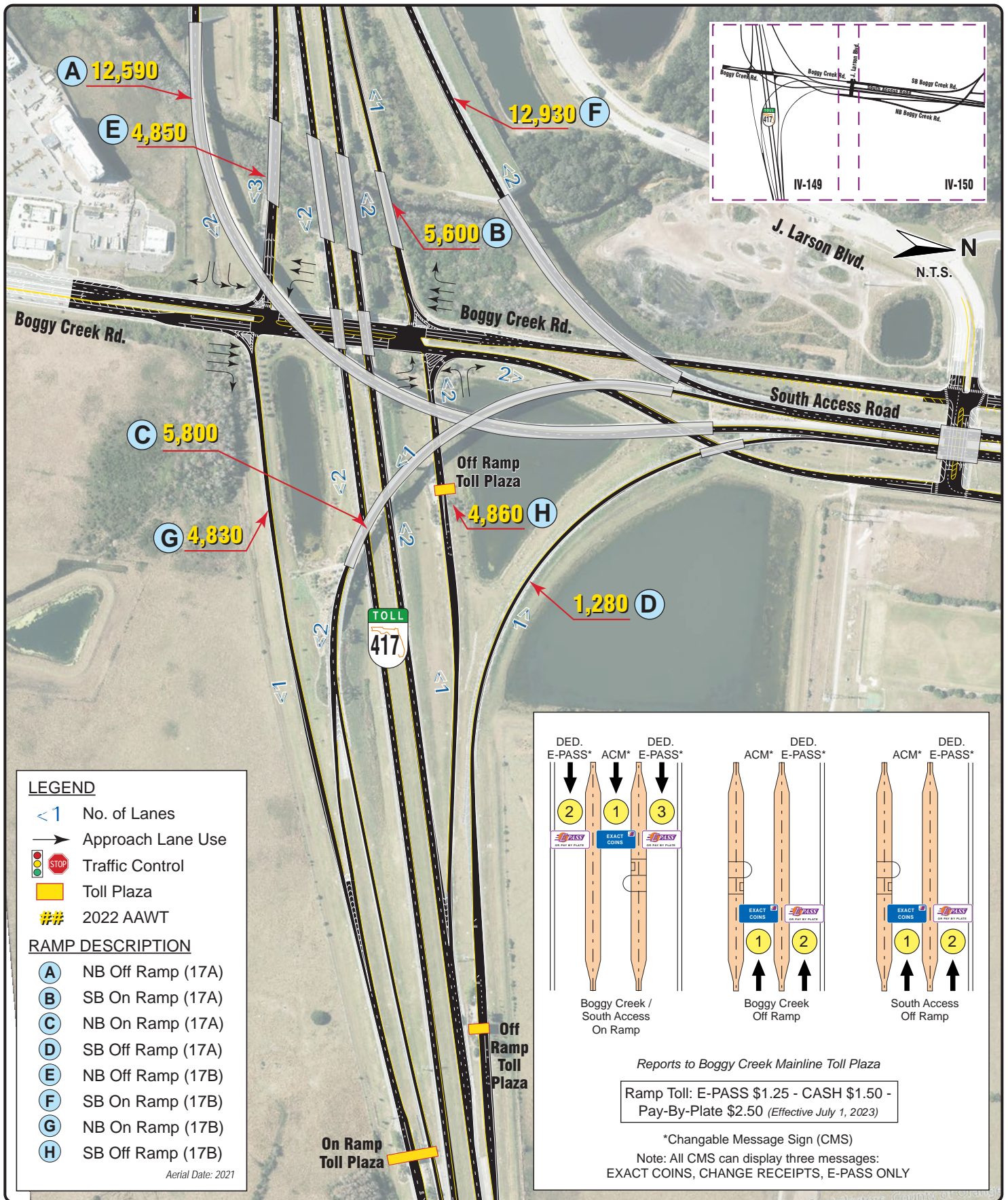

LEGEND

- <1 No. of Lanes
- Approach Lane Use
- Traffic Control
- Toll Plaza
- ## 2022 AAWT

RAMP DESCRIPTION

- A** NB Off Ramp (17A)
- B** SB On Ramp (17A)
- C** NB On Ramp (17A)
- D** SB Off Ramp (17A)
- E** NB Off Ramp (17B)
- F** SB On Ramp (17B)
- G** NB On Ramp (17B)
- H** SB Off Ramp (17B)

Aerial Date: 2021

DED. E-PASS* ACM* DED. E-PASS* DED. ACM* DED. E-PASS* DED. ACM* DED. E-PASS*

Boggy Creek / South Access On Ramp Boggy Creek Off Ramp South Access Off Ramp

Reports to Boggy Creek Mainline Toll Plaza

Ramp Toll: E-PASS \$1.25 - CASH \$1.50 - Pay-By-Plate \$2.50 (Effective July 1, 2023)

*Changable Message Sign (CMS)
Note: All CMS can display three messages: EXACT COINS, CHANGE RECEIPTS, E-PASS ONLY



Exit 17A&B - Boggy Creek Road and South Access Road (1)
SR 417 (CENTRAL FLORIDA GREENEWAY)

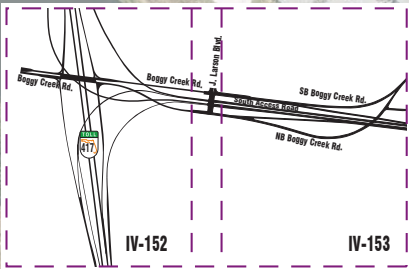

10,300 **B**

9,800 **A**

LEGEND

- <1 No. of Lanes
- Approach Lane Use
- ⬆️ STOP Traffic Control
- 🟡 Toll Plaza
- ## 2022 AAWT

RAMP DESCRIPTION

- A** NB Ramp from BCR to SAR
- B** SB Ramp from RCR to SAR

Aerial Date: 2021



Exit 17A&B - Boggy Creek Road and South Access Road (2)
 SR 417 (CENTRAL FLORIDA GREENEWAY)

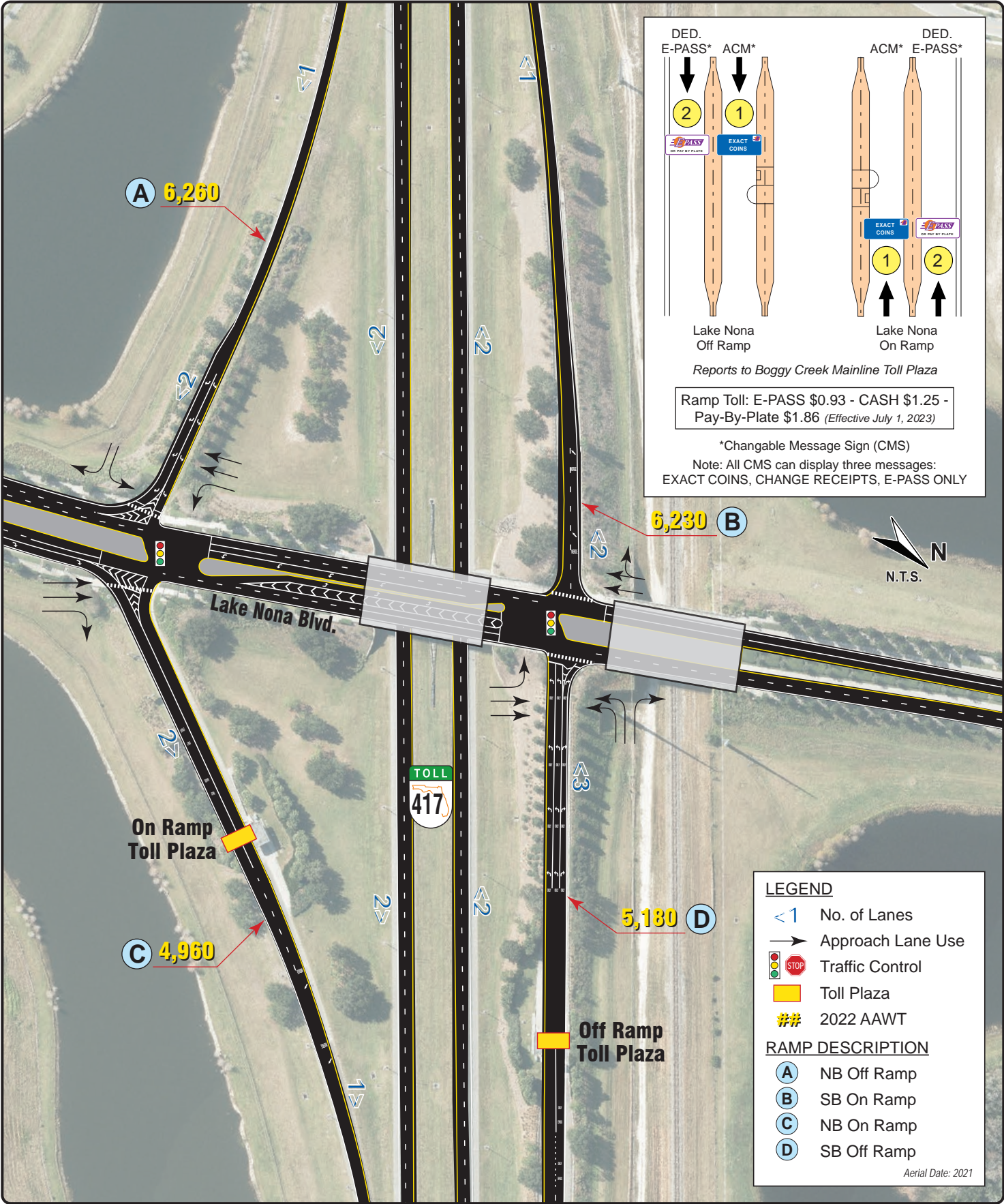

LEGEND

- No. of Lanes
- Approach Lane Use
- Traffic Control
- Toll Plaza
- 2022 AAWT

RAMP DESCRIPTION

- (A)** NB Off Ramp
- (B)** SB On Ramp
- (C)** NB On Ramp
- (D)** SB Off Ramp

Aerial Date: 2021

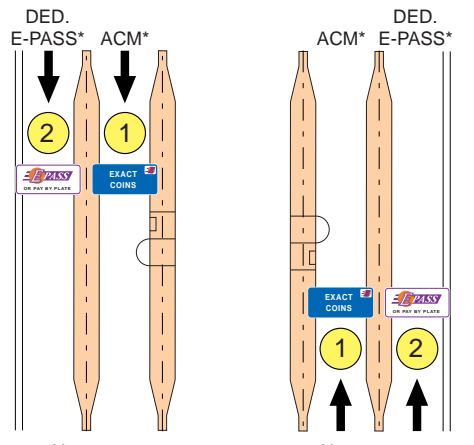
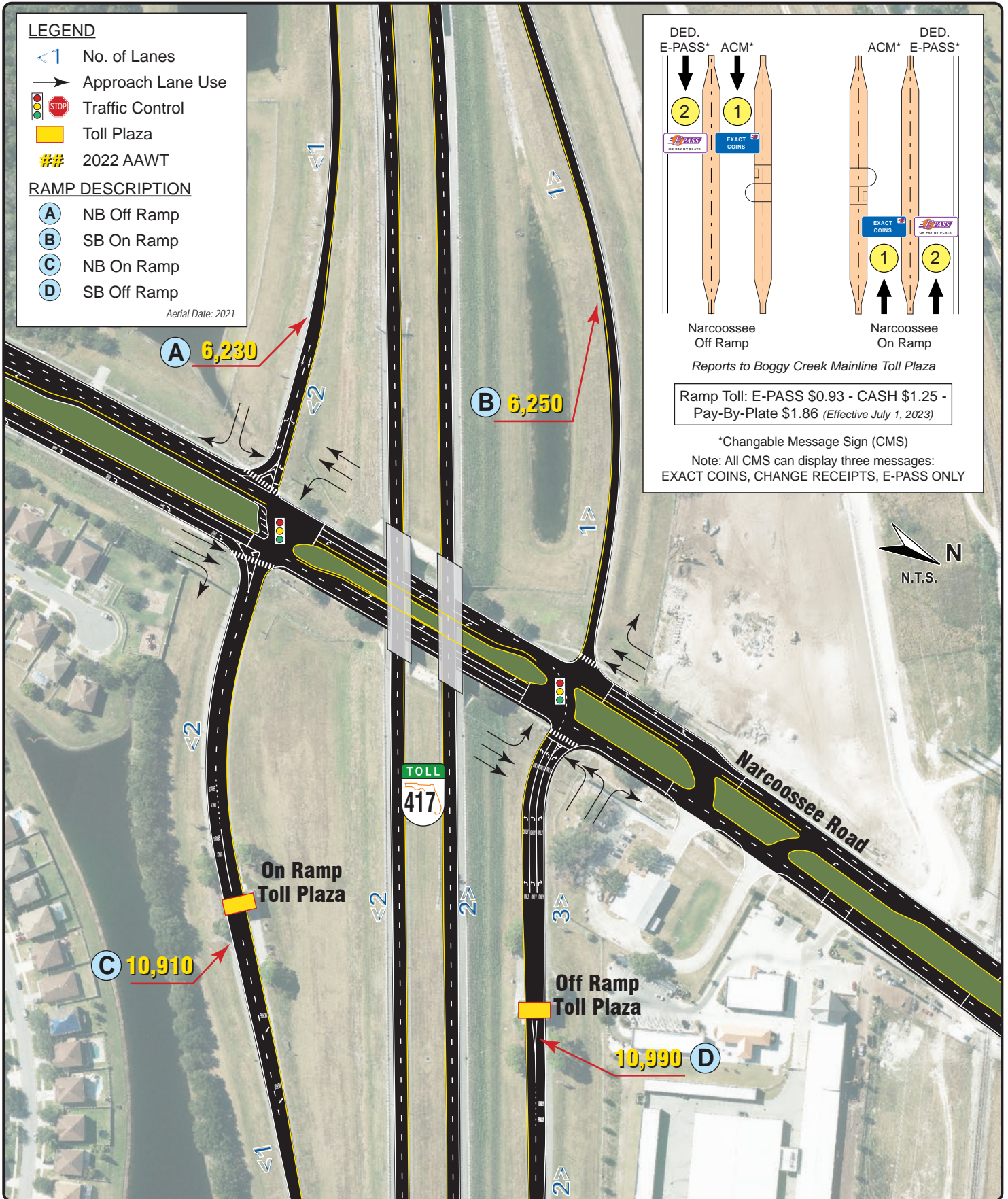

Narcoossee Off Ramp
Narcoossee On Ramp
Reports to Boggy Creek Mainline Toll Plaza

Ramp Toll: E-PASS \$0.93 - CASH \$1.25 - Pay-By-Plate \$1.86 (Effective July 1, 2023)

*Changable Message Sign (CMS)
Note: All CMS can display three messages: EXACT COINS, CHANGE RECEIPTS, E-PASS ONLY



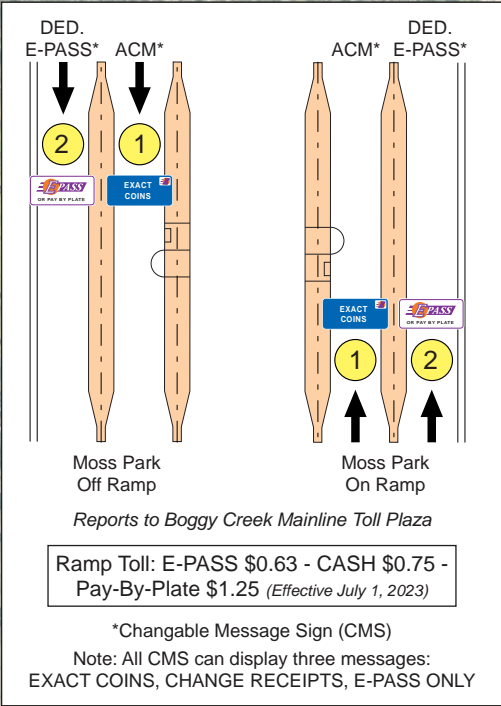
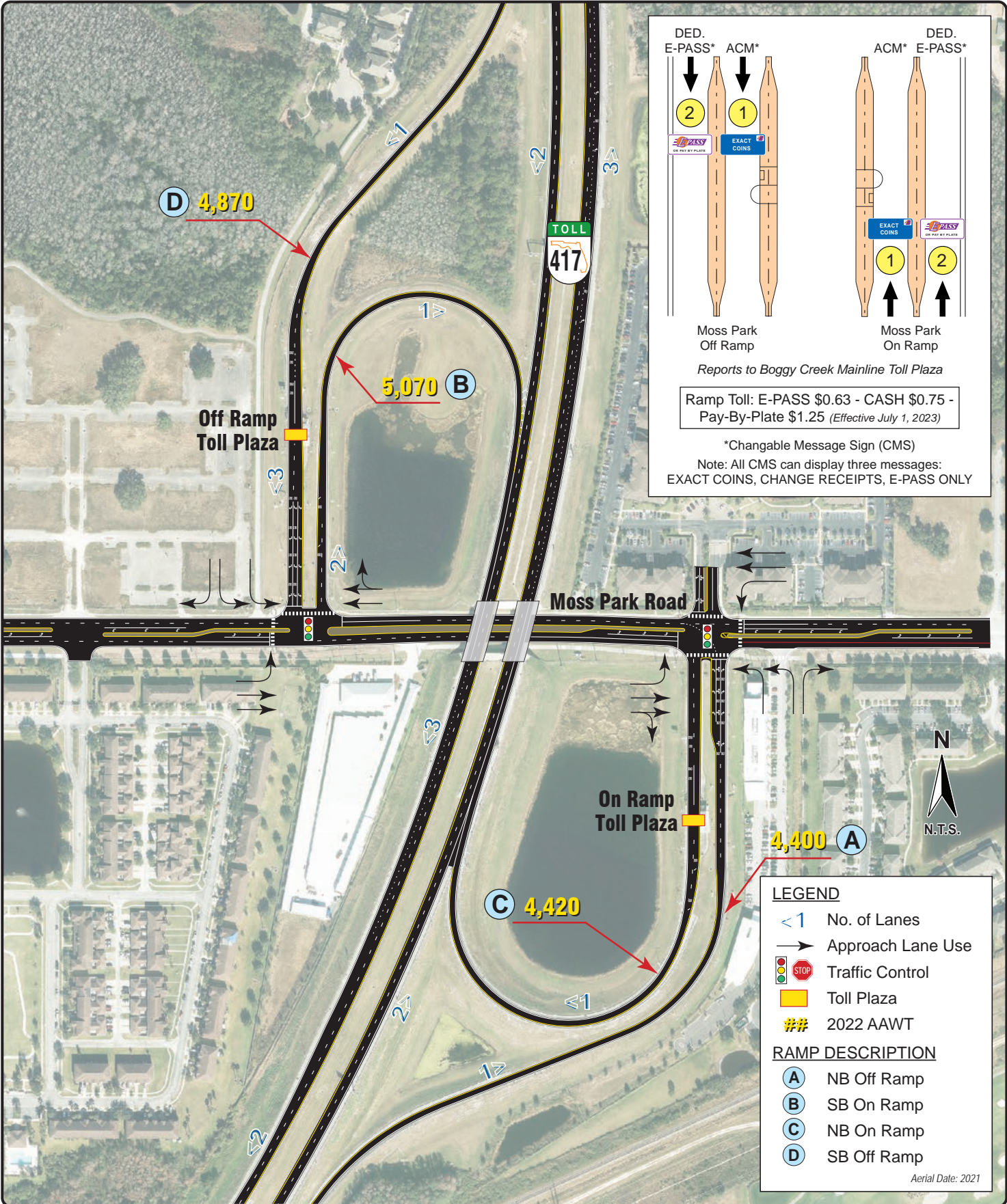

LEGEND

- <1 No. of Lanes
- Approach Lane Use
- STOP Traffic Control
- Toll Plaza
- ## 2022 AAWT

RAMP DESCRIPTION

- (A) NB Off Ramp
- (B) SB On Ramp
- (C) NB On Ramp
- (D) SB Off Ramp

Aerial Date: 2021

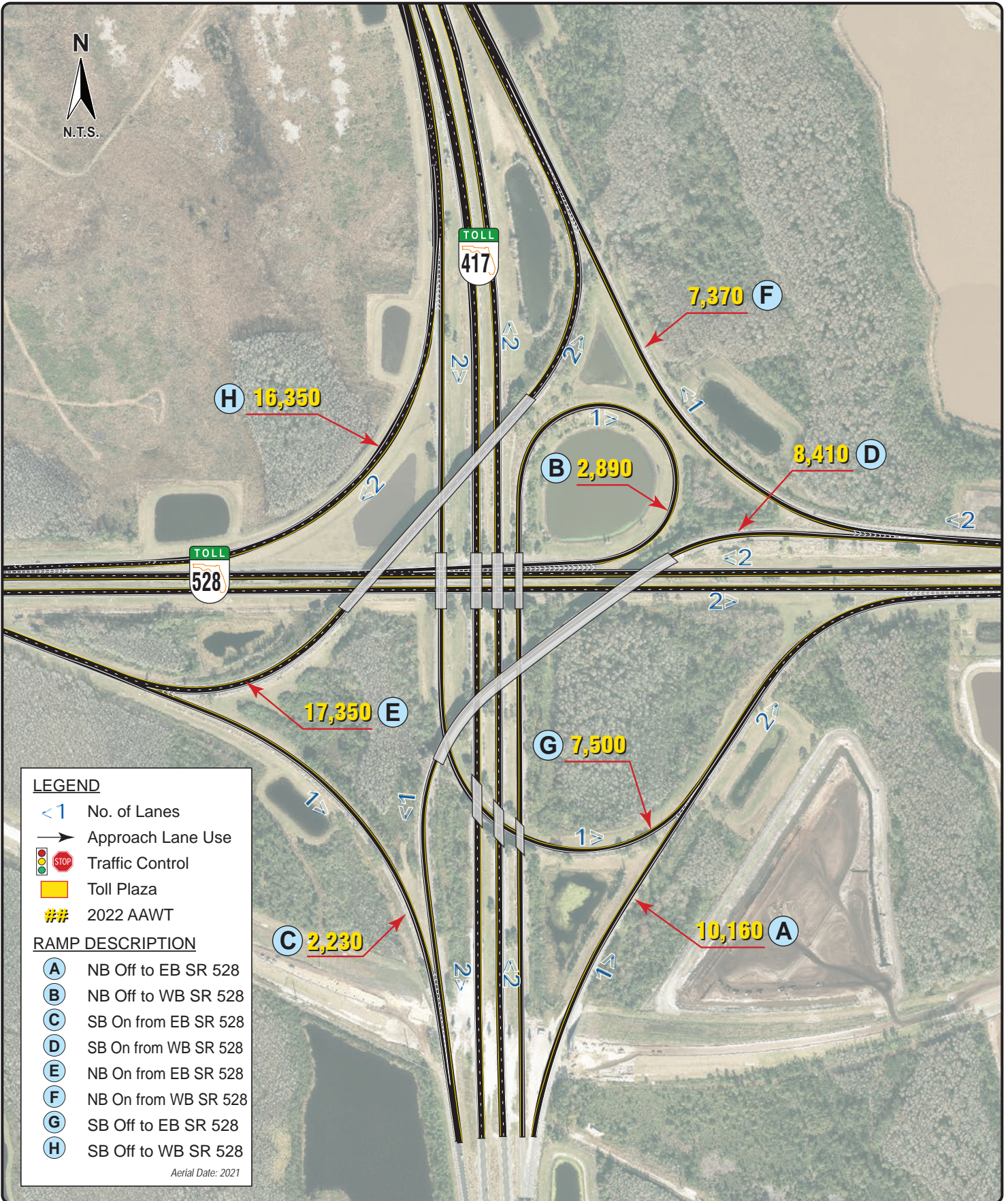

LEGEND

- <1 No. of Lanes
- Approach Lane Use
- Traffic Control
- Toll Plaza
- ## 2022 AAWT

RAMP DESCRIPTION

- A** NB Off to EB SR 528
- B** NB Off to WB SR 528
- C** SB On from EB SR 528
- D** SB On from WB SR 528
- E** NB On from EB SR 528
- F** NB On from WB SR 528
- G** SB Off to EB SR 528
- H** SB Off to WB SR 528

Aerial Date: 2021

LEGEND

- <1 No. of Lanes
- Approach Lane Use
- STOP Traffic Control
- Toll Plaza
- ## 2022 AAWT

RAMP DESCRIPTION

- (A) NB Off Ramp
- (B) SB On Ramp
- (C) NB On Ramp
- (D) SB Off Ramp

Aerial Date: 2021

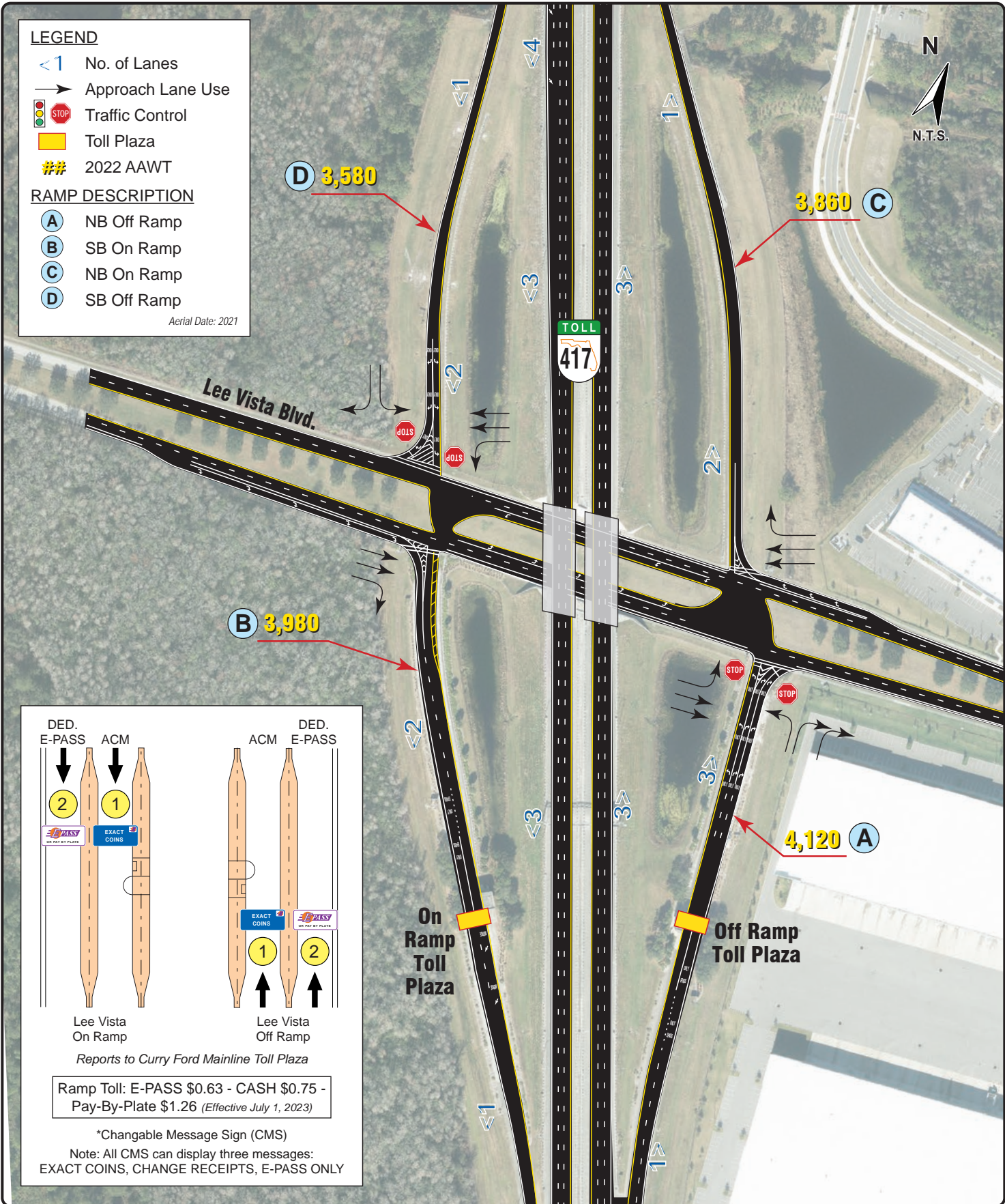

DED. E-PASS	ACM	DED. ACM	E-PASS
Lee Vista On Ramp	Lee Vista On Ramp	Lee Vista Off Ramp	Lee Vista Off Ramp

Reports to Curry Ford Mainline Toll Plaza

Ramp Toll: E-PASS \$0.63 - CASH \$0.75 - Pay-By-Plate \$1.26 (Effective July 1, 2023)

*Changable Message Sign (CMS)
 Note: All CMS can display three messages: EXACT COINS, CHANGE RECEIPTS, E-PASS ONLY

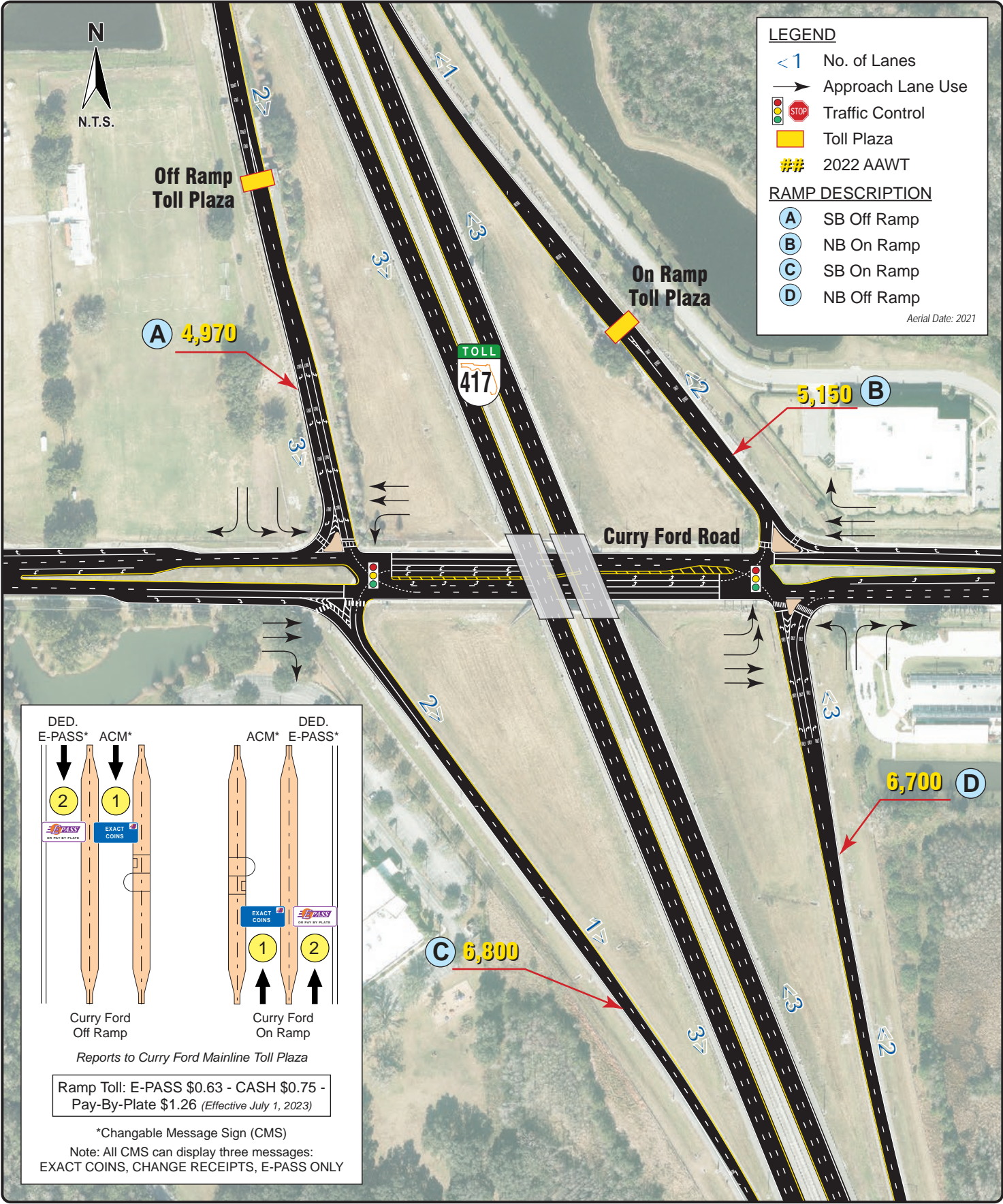

LEGEND

- < 1 No. of Lanes
- Approach Lane Use
- STOP Traffic Control
- Toll Plaza
- ## 2022 AAWT

RAMP DESCRIPTION

- (A) SB Off Ramp
- (B) NB On Ramp
- (C) SB On Ramp
- (D) NB Off Ramp

Aerial Date: 2021

DED. E-PASS*	ACM*	DED. ACM*	E-PASS*
2	1	1	2
Curry Ford Off Ramp		Curry Ford On Ramp	
Reports to Curry Ford Mainline Toll Plaza			
Ramp Toll: E-PASS \$0.63 - CASH \$0.75 - Pay-By-Plate \$1.26 (Effective July 1, 2023)			
*Changable Message Sign (CMS)			
Note: All CMS can display three messages: EXACT COINS, CHANGE RECEIPTS, E-PASS ONLY			

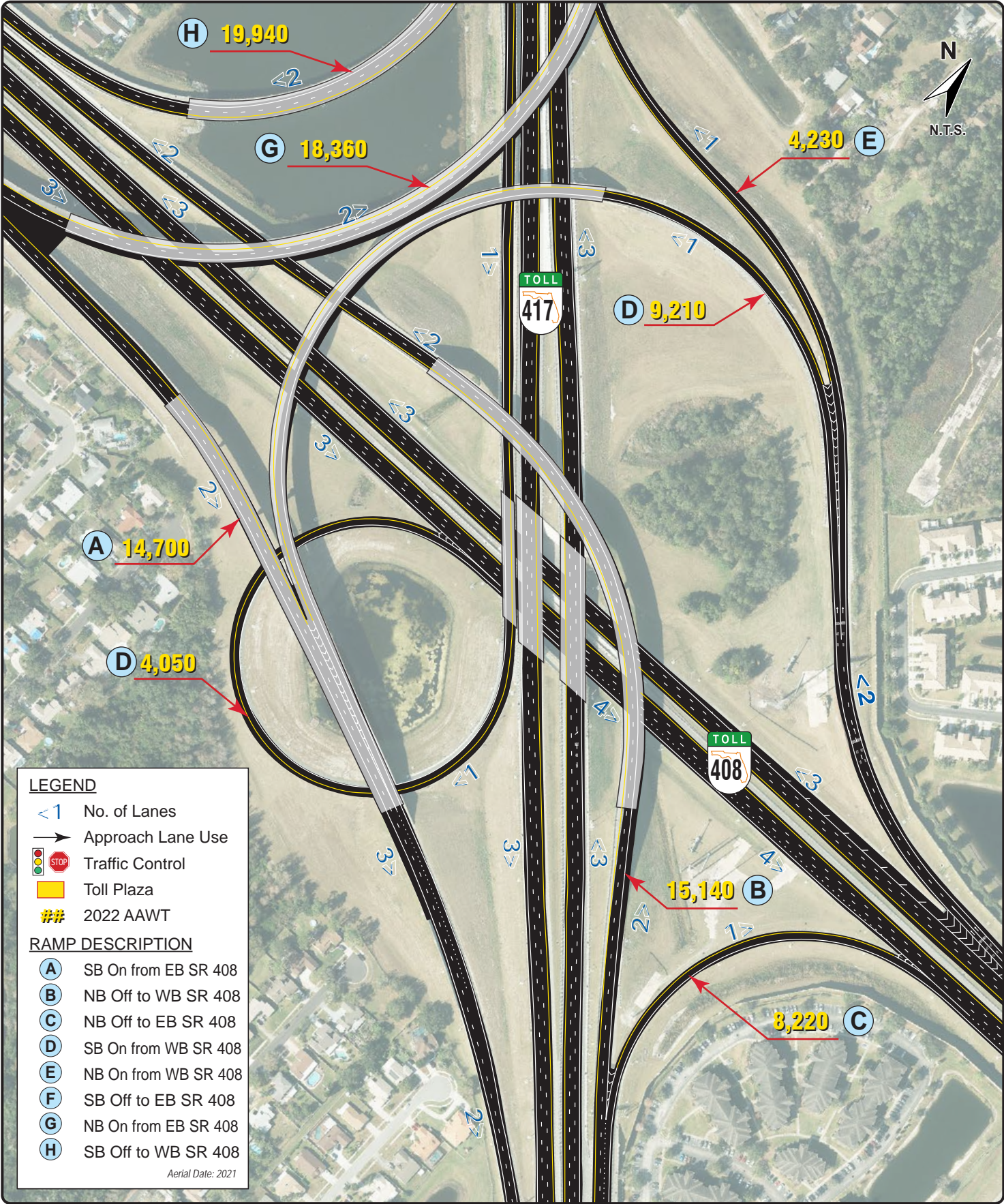

LEGEND

- <1 No. of Lanes
- Approach Lane Use
- Traffic Control
- Toll Plaza
- ## 2022 AAWT

RAMP DESCRIPTION

- A** SB On from EB SR 408
- B** NB Off to WB SR 408
- C** NB Off to EB SR 408
- D** SB On from WB SR 408
- E** NB On from WB SR 408
- F** SB Off to EB SR 408
- G** NB On from EB SR 408
- H** SB Off to WB SR 408

Aerial Date: 2021

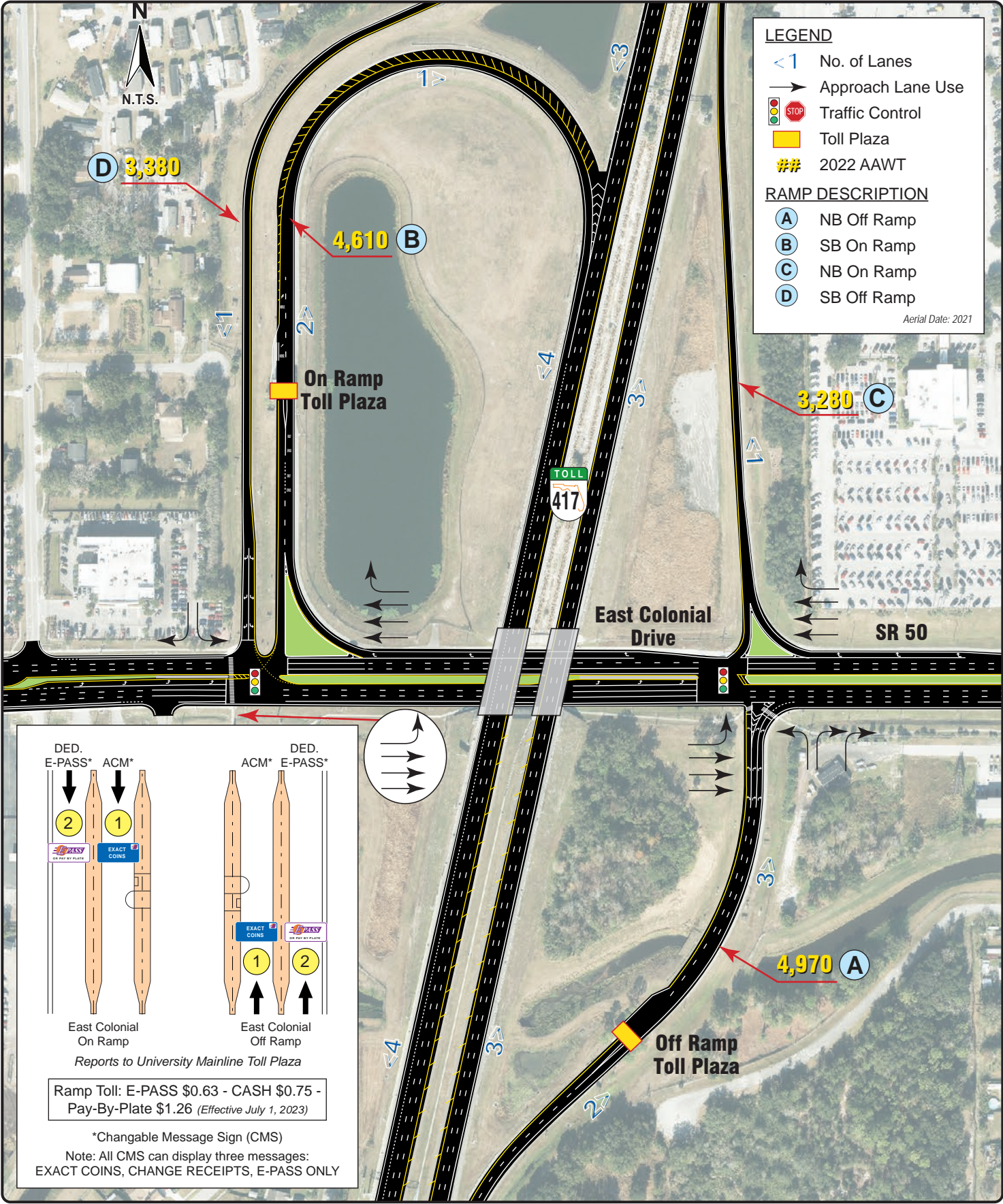

LEGEND

- < 1 No. of Lanes
- Approach Lane Use
- 🚦 STOP Traffic Control
- 🟡 Toll Plaza
- ## 2022 AAWT

RAMP DESCRIPTION

- (A) NB Off Ramp
- (B) SB On Ramp
- (C) NB On Ramp
- (D) SB Off Ramp

Aerial Date: 2021

DED.
E-PASS* ACM*

East Colonial
On Ramp

DED.
ACM* E-PASS*

East Colonial
Off Ramp

Reports to University Mainline Toll Plaza

Ramp Toll: E-PASS \$0.63 - CASH \$0.75 - Pay-By-Plate \$1.26 (Effective July 1, 2023)

*Changable Message Sign (CMS)
Note: All CMS can display three messages:
EXACT COINS, CHANGE RECEIPTS, E-PASS ONLY

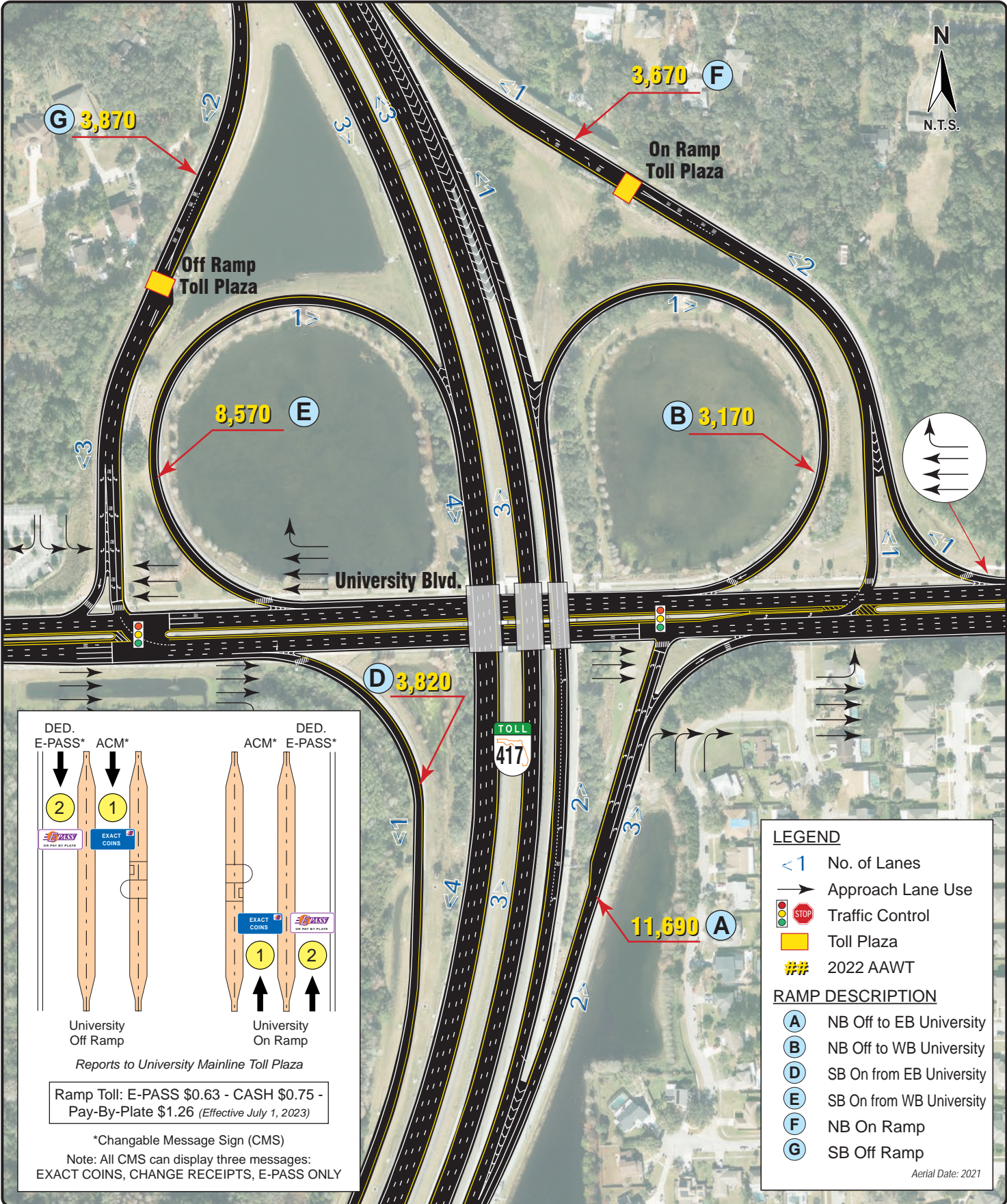

LEGEND

- <1 No. of Lanes
- ➔ Approach Lane Use
- 🚦 STOP Traffic Control
- 🟡 Toll Plaza
- ## 2022 AAWT

RAMP DESCRIPTION

- A** NB Off to EB University
- B** NB Off to WB University
- D** SB On from EB University
- E** SB On from WB University
- F** NB On Ramp
- G** SB Off Ramp

Aerial Date: 2021

DED. E-PASS*	ACM*	DED. ACM*	E-PASS*
2	1	1	2
University Off Ramp		University On Ramp	
Reports to University Mainline Toll Plaza			
Ramp Toll: E-PASS \$0.63 - CASH \$0.75 - Pay-By-Plate \$1.26 (Effective July 1, 2023)			
*Changable Message Sign (CMS)			
Note: All CMS can display three messages: EXACT COINS, CHANGE RECEIPTS, E-PASS ONLY			

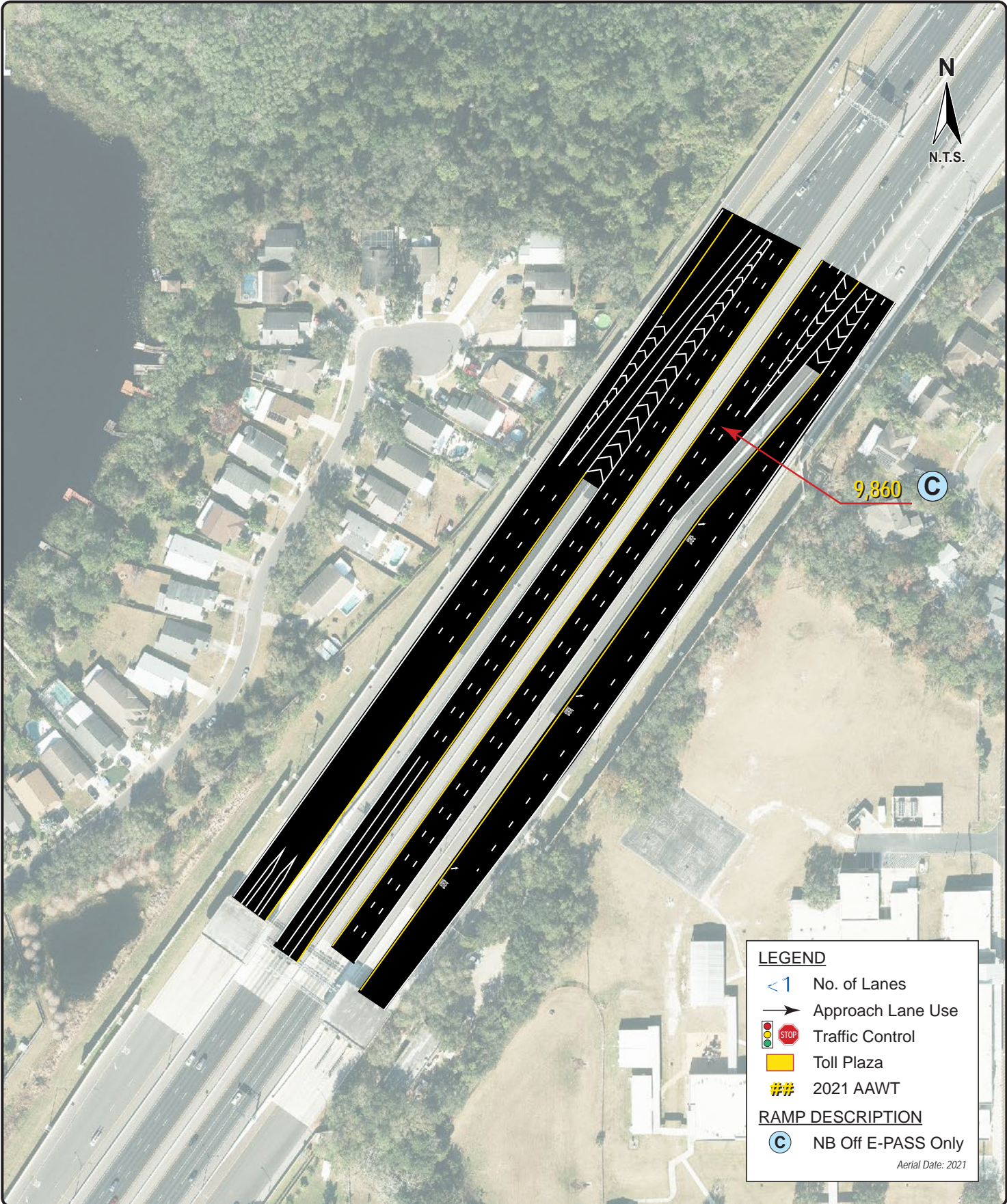

9,860 C

LEGEND

- <1 No. of Lanes
- Approach Lane Use
- 🚦 STOP Traffic Control
- 🟡 Toll Plaza
- ## 2021 AAWT

RAMP DESCRIPTION

- C NB Off E-PASS Only

Aerial Date: 2021

WESTERN BELTWAY AND WEKIVA PARKWAY







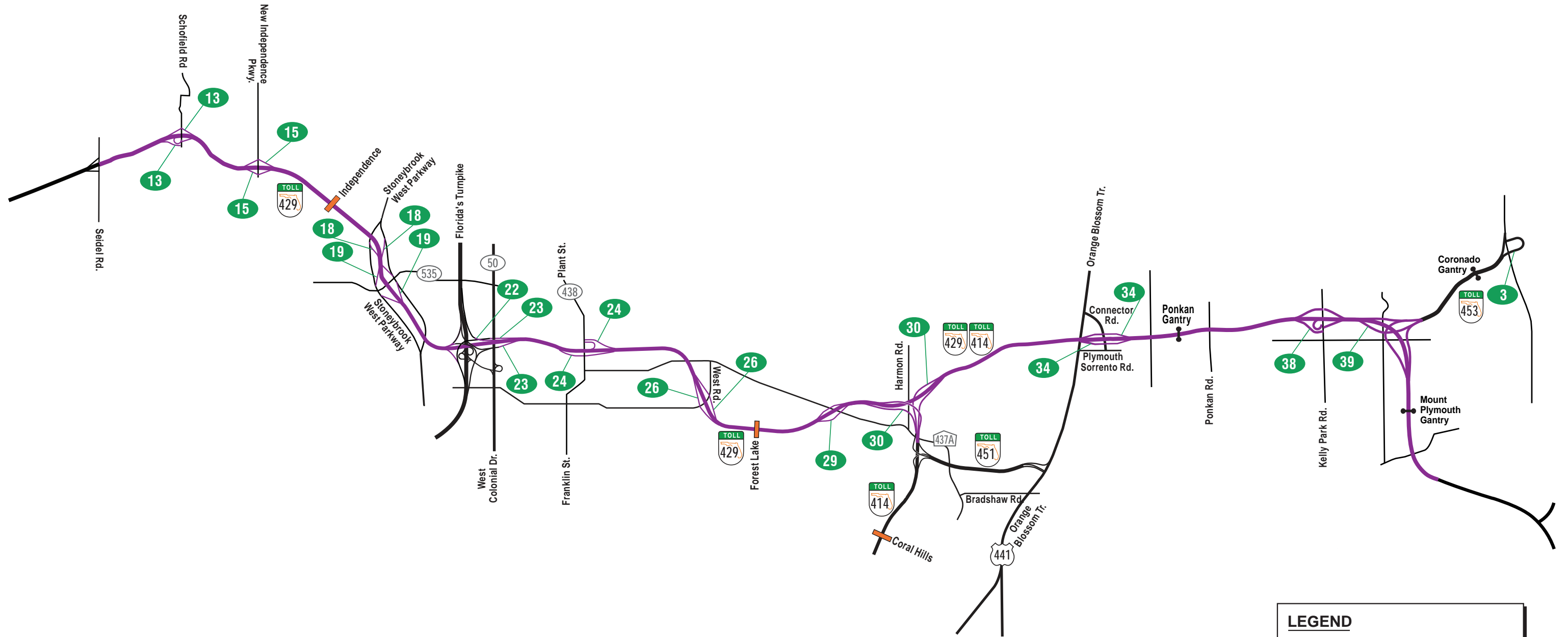

Western Beltway

Wekiva Parkway



LEGEND

-  Exit Number
-  Existing SR 429
-  Mainline Toll Plaza
-  Mainline Toll Gantry



Exit Numbers
 SR 429 - WESTERN BELTWAY AND WEKIVA PARKWAY

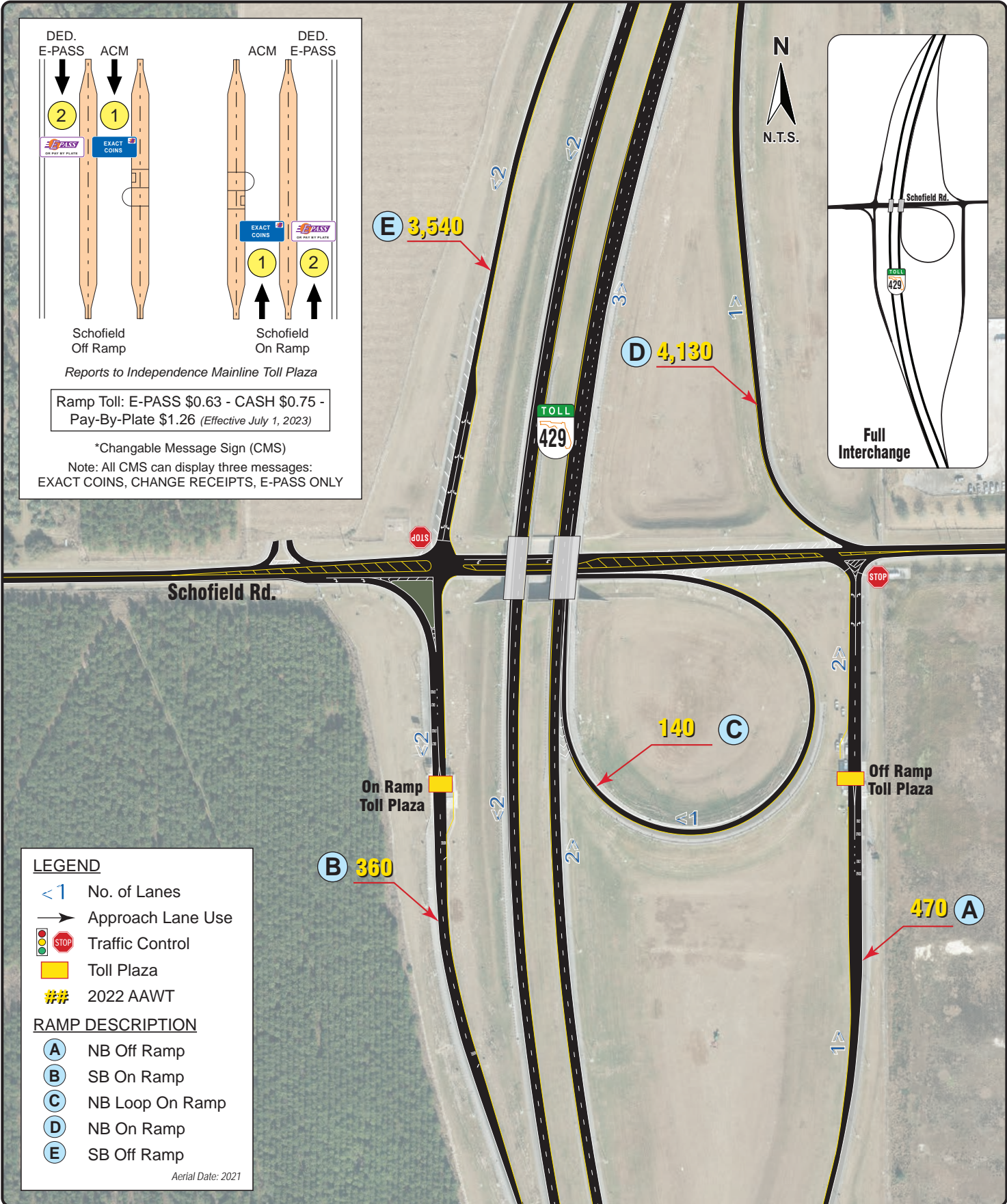
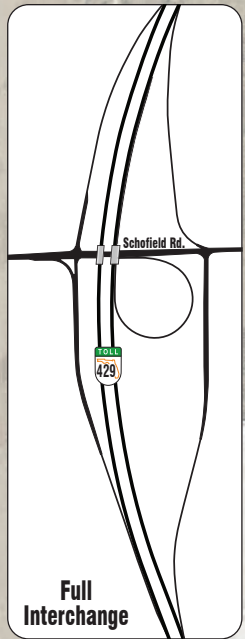
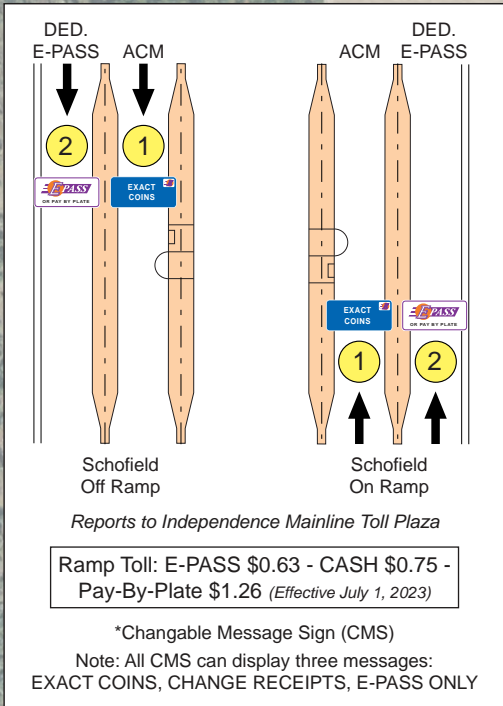

LEGEND

- <1 No. of Lanes
- Approach Lane Use
- STOP Traffic Control
- Yellow Rectangle Toll Plaza
- ## 2022 AAWT

RAMP DESCRIPTION

- (A) NB Off Ramp
- (B) SB On Ramp
- (C) NB Loop On Ramp
- (D) NB On Ramp
- (E) SB Off Ramp

Aerial Date: 2021

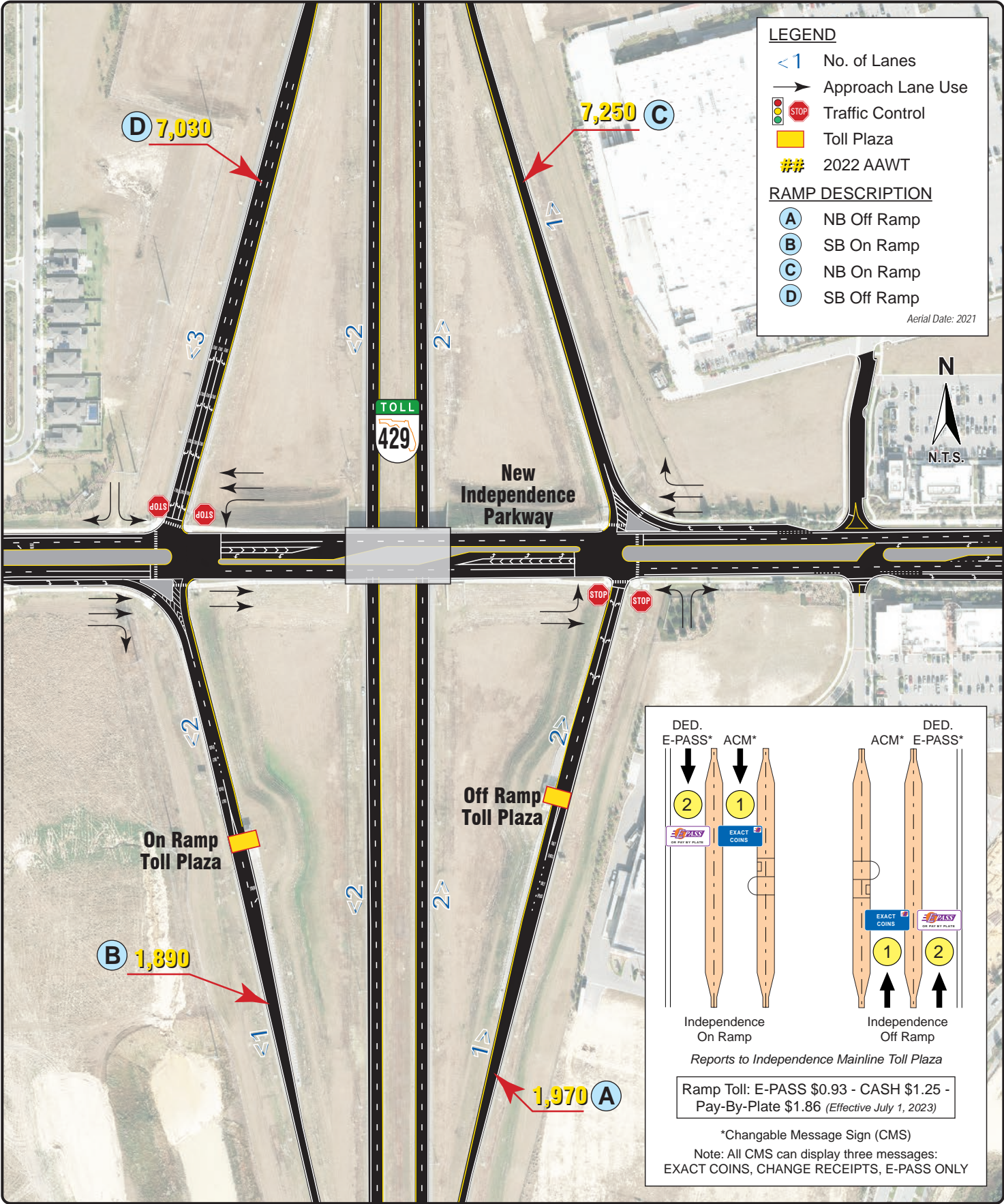

LEGEND

- <1 No. of Lanes
- Approach Lane Use
- STOP Traffic Control
- Toll Plaza
- ## 2022 AAWT

RAMP DESCRIPTION

- A NB Off Ramp
- B SB On Ramp
- C NB On Ramp
- D SB Off Ramp

Aerial Date: 2021

DED. E-PASS*	ACM*	DED. ACM*	E-PASS*
2	1	1	2
INDEPENDENCE ON RAMP	INDEPENDENCE ON RAMP	INDEPENDENCE OFF RAMP	INDEPENDENCE OFF RAMP

Reports to Independence Mainline Toll Plaza

Ramp Toll: E-PASS \$0.93 - CASH \$1.25 - Pay-By-Plate \$1.86 (Effective July 1, 2023)

*Changable Message Sign (CMS)
 Note: All CMS can display three messages: EXACT COINS, CHANGE RECEIPTS, E-PASS ONLY

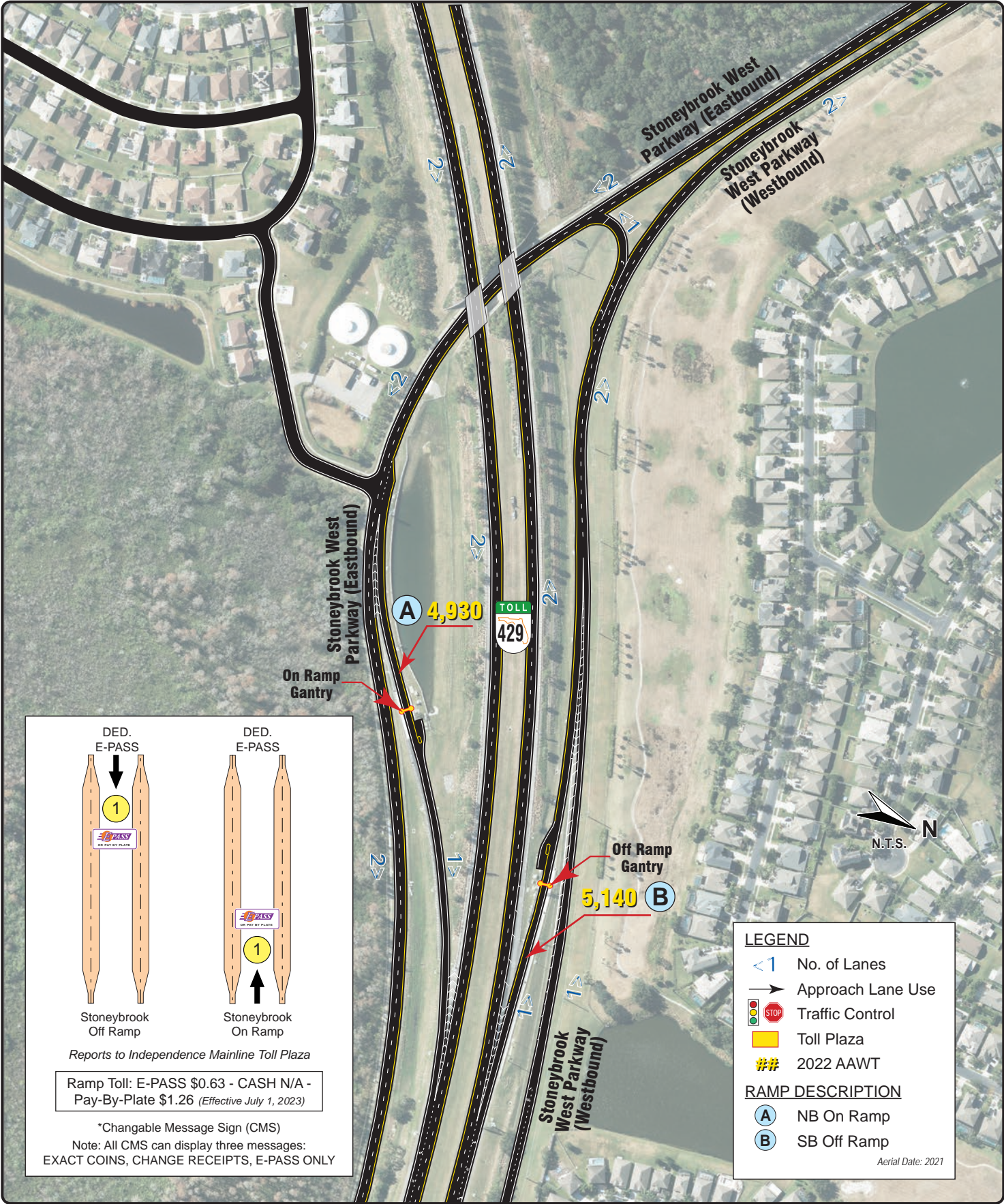

DED. E-PASS

Stoneybrook Off Ramp

DED. E-PASS

Stoneybrook On Ramp

Reports to Independence Mainline Toll Plaza

Ramp Toll: E-PASS \$0.63 - CASH N/A - Pay-By-Plate \$1.26 (Effective July 1, 2023)

*Changable Message Sign (CMS)
Note: All CMS can display three messages: EXACT COINS, CHANGE RECEIPTS, E-PASS ONLY

LEGEND

- < 1 No. of Lanes
- Approach Lane Use
- Traffic Control
- Toll Plaza
- ## 2022 AAWT

RAMP DESCRIPTION

- (A) NB On Ramp
- (B) SB Off Ramp

Aerial Date: 2021

LEGEND

- <1 No. of Lanes
- ➔ Approach Lane Use
- 🚦 STOP Traffic Control
- 🟡 Toll Plaza
- ## 2022 AAWT

RAMP DESCRIPTION

- Ⓐ NB Off Ramp
- Ⓑ SB On Ramp
- Ⓒ NB On Ramp
- Ⓓ SB Off Ramp

Aerial Date: 2021

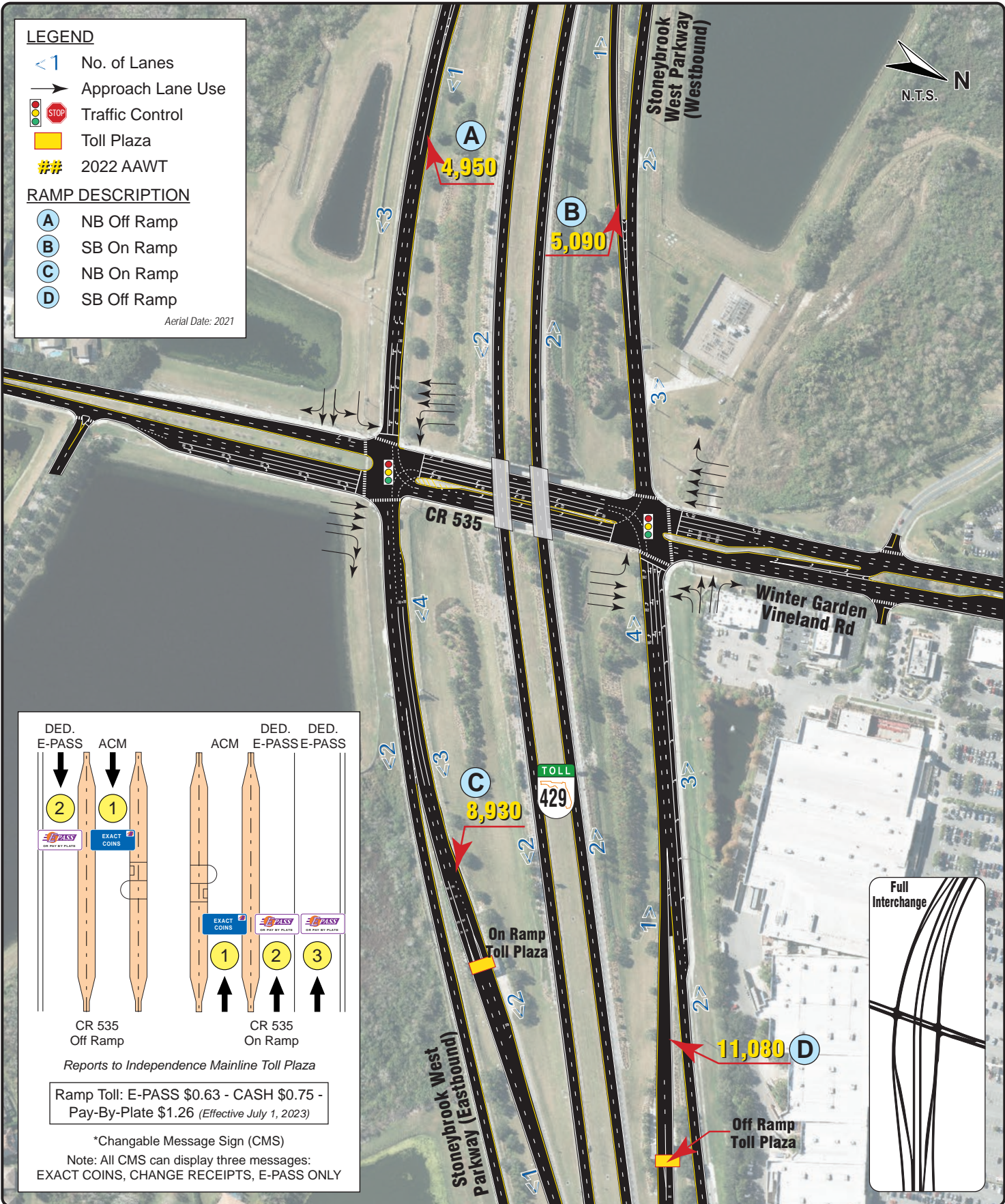



DED. E-PASS	ACM	DED. ACM	DED. E-PASS	DED. E-PASS
2	1	1	2	3
CR 535 Off Ramp		CR 535 On Ramp		

Reports to Independence Mainline Toll Plaza

Ramp Toll: E-PASS \$0.63 - CASH \$0.75 - Pay-By-Plate \$1.26 (Effective July 1, 2023)

*Changeable Message Sign (CMS)
 Note: All CMS can display three messages: EXACT COINS, CHANGE RECEIPTS, E-PASS ONLY

LEGEND

- <1 No. of Lanes
- Approach Lane Use
-  Traffic Control
-  Toll Plaza
- ## 2022 AAWT

RAMP DESCRIPTION

- A** NB On from SR 50
- B** SB Off to SR 50
- C** NB Off to NB Turnpike
- D** NB Off to SB Turnpike
- E** SB On from NB Turnpike
- F** SB On from SB Turnpike
- G** NB Off to SR 50
- H** SB On from SR 50
- I** NB On from NB Turnpike
- J** NB On from SB Turnpike
- K** SB Off to NB Turnpike
- L** SB Off to SB Turnpike

Aerial Date: 2021

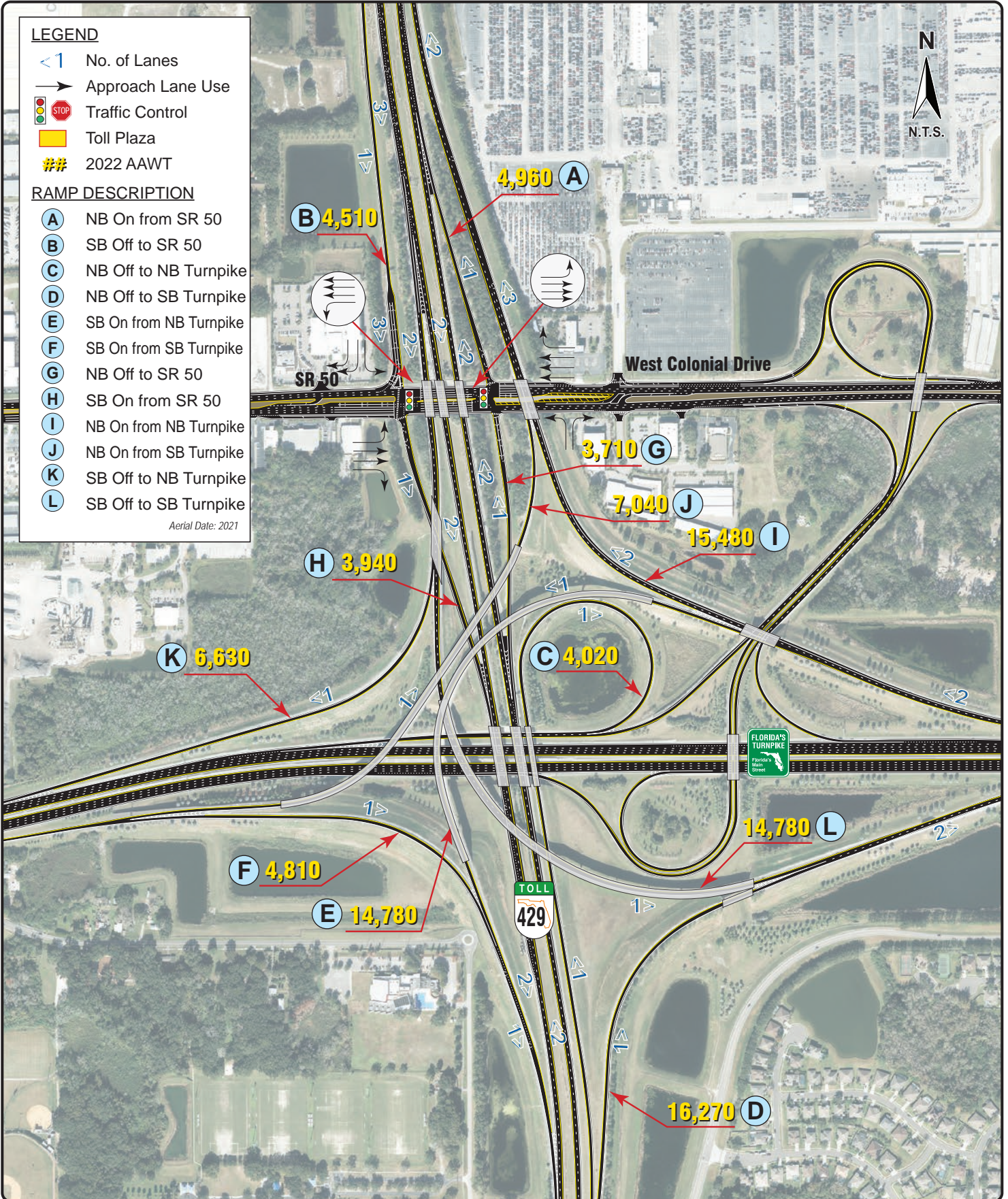

LEGEND

- <1 No. of Lanes
- ➔ Approach Lane Use
- 🚦 Traffic Control
- 🟡 Toll Plaza
- ## 2022 AAWT

RAMP DESCRIPTION

- Ⓐ NB Off Ramp
- Ⓑ SB On Ramp
- Ⓒ NB On Ramp
- Ⓓ SB Off Ramp

Aerial Date: 2021

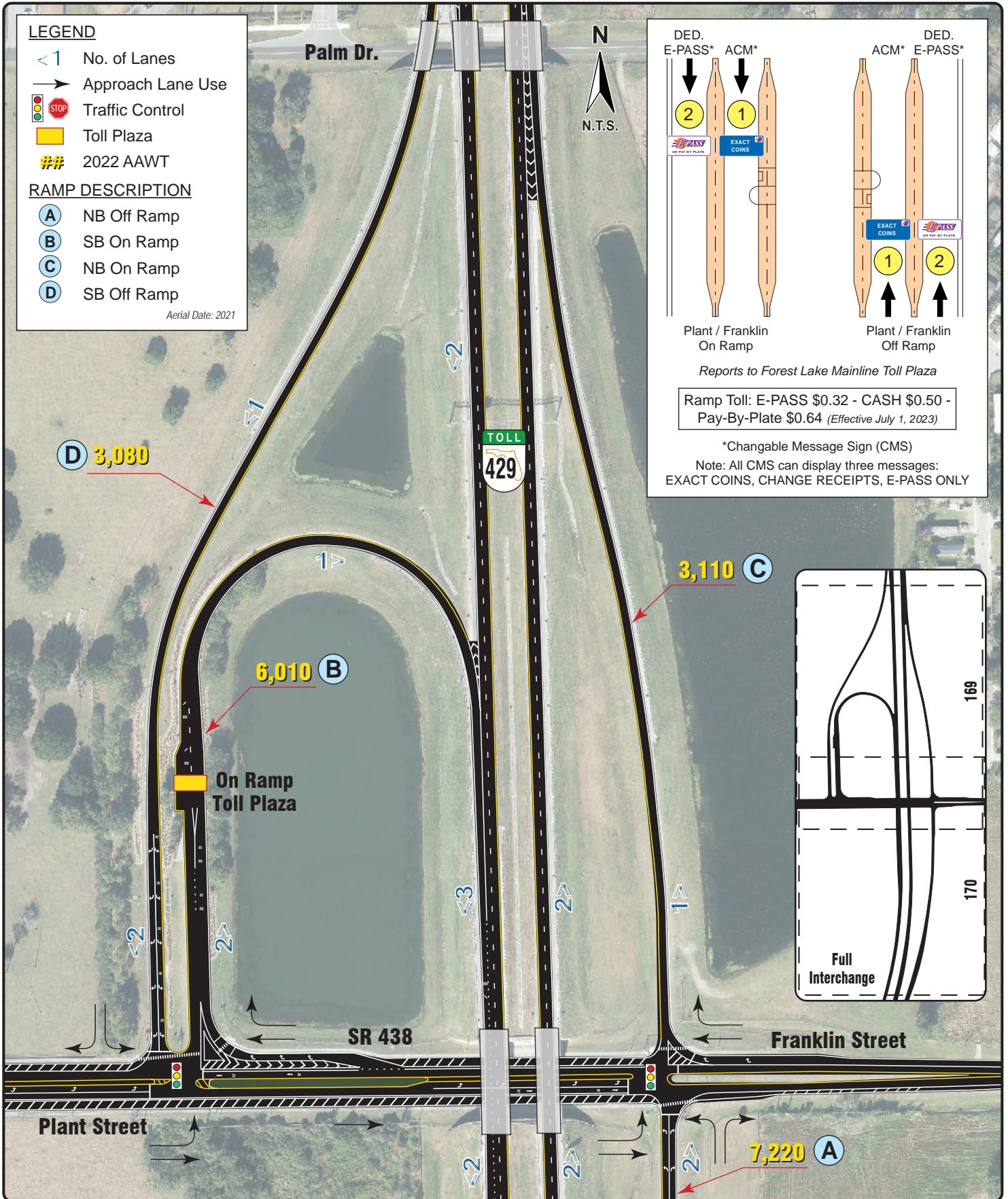

DED. E-PASS* ACM* DED. ACM* E-PASS*

2 1 1 2

Plant / Franklin On Ramp Plant / Franklin Off Ramp

Reports to Forest Lake Mainline Toll Plaza

Ramp Toll: E-PASS \$0.32 - CASH \$0.50 - Pay-By-Plate \$0.64 (Effective July 1, 2023)

*Changable Message Sign (CMS)
Note: All CMS can display three messages: EXACT COINS, CHANGE RECEIPTS, E-PASS ONLY

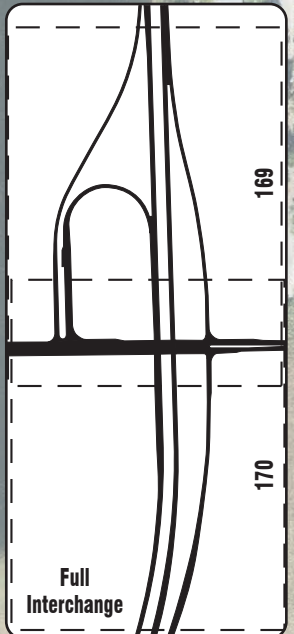

Exit 24 - Plant Street/Franklin Street (SR 438)
SR 429 (WESTERN BELTWAY)

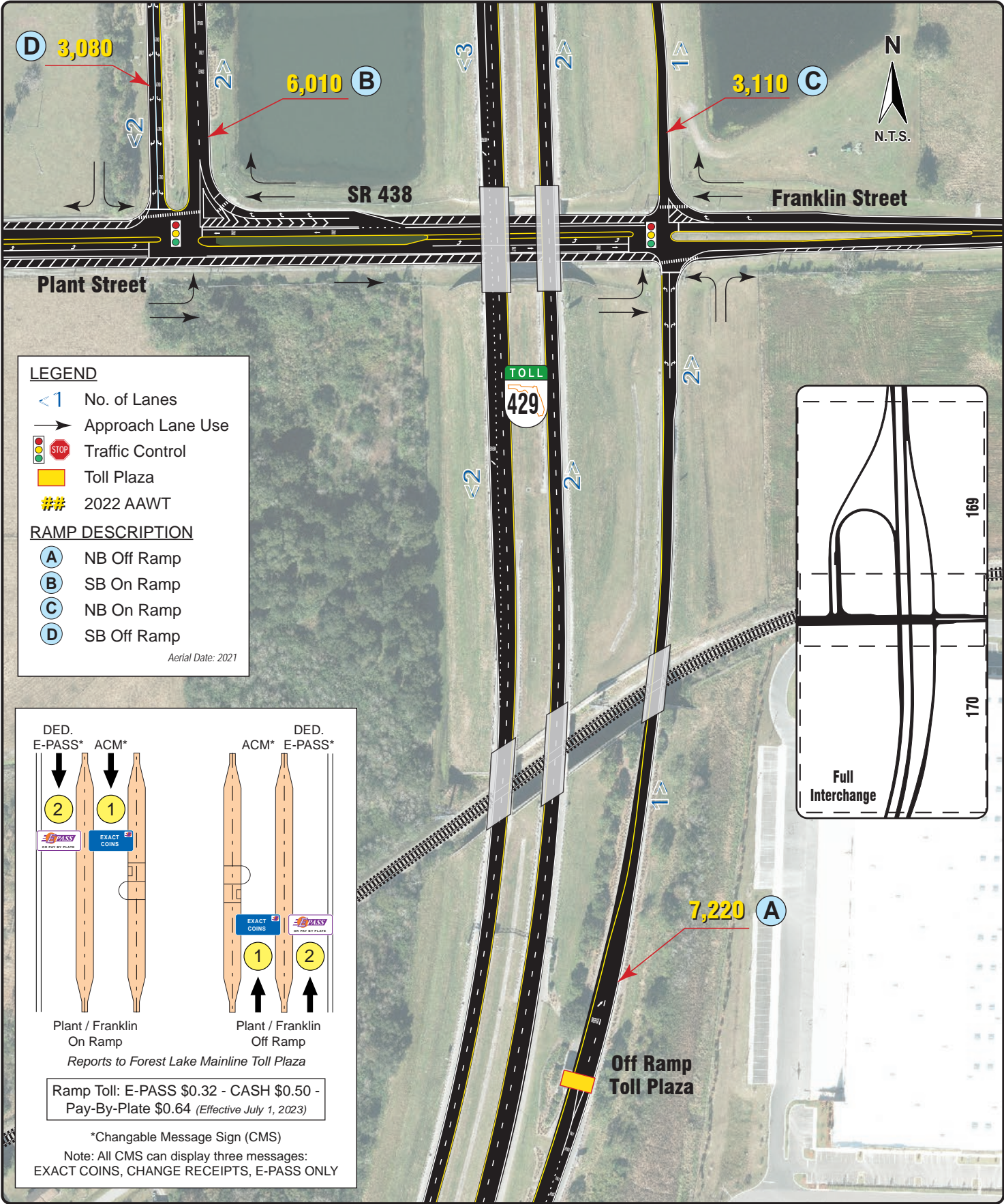

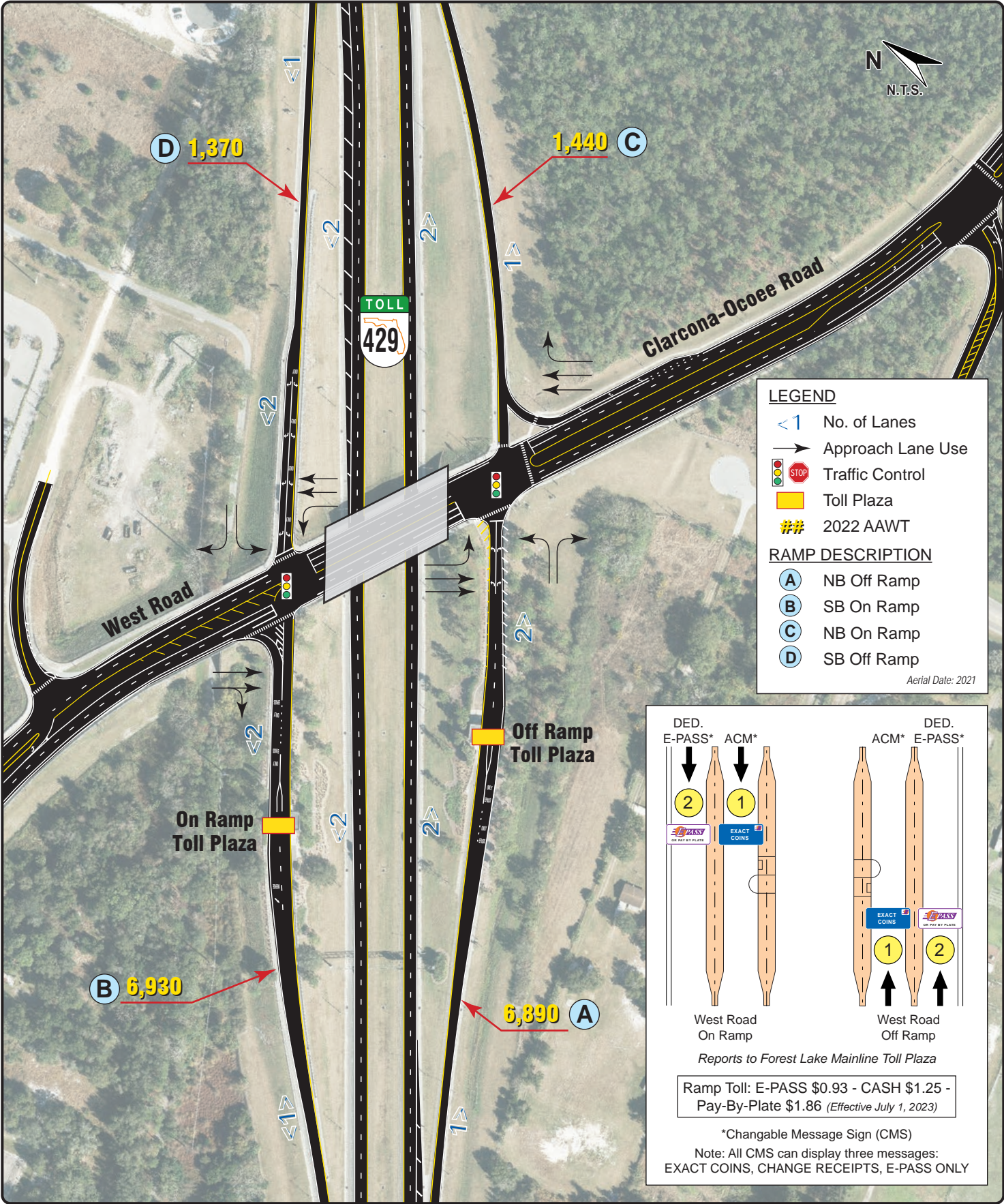

LEGEND

- <1 No. of Lanes
- Approach Lane Use
- Traffic Control
- Toll Plaza
- ## 2022 AAWT

RAMP DESCRIPTION

- (A)** NB Off Ramp
- (B)** SB On Ramp
- (C)** NB On Ramp
- (D)** SB Off Ramp

Aerial Date: 2021

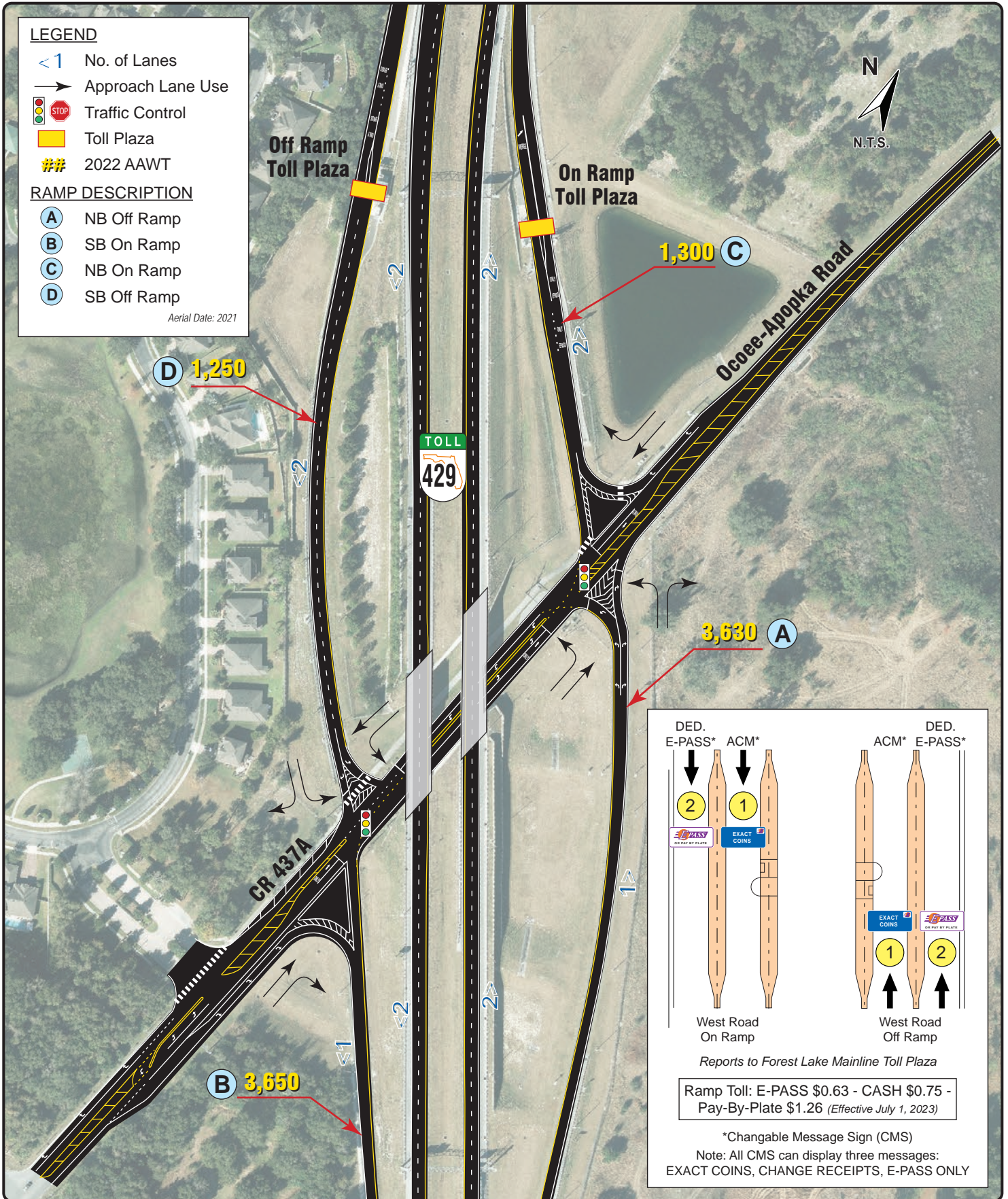

DED. E-PASS*	ACM*	DED. ACM*	E-PASS*
West Road On Ramp		West Road Off Ramp	

Reports to Forest Lake Mainline Toll Plaza

Ramp Toll: E-PASS \$0.63 - CASH \$0.75 - Pay-By-Plate \$1.26 (Effective July 1, 2023)

*Changable Message Sign (CMS)
 Note: All CMS can display three messages: EXACT COINS, CHANGE RECEIPTS, E-PASS ONLY

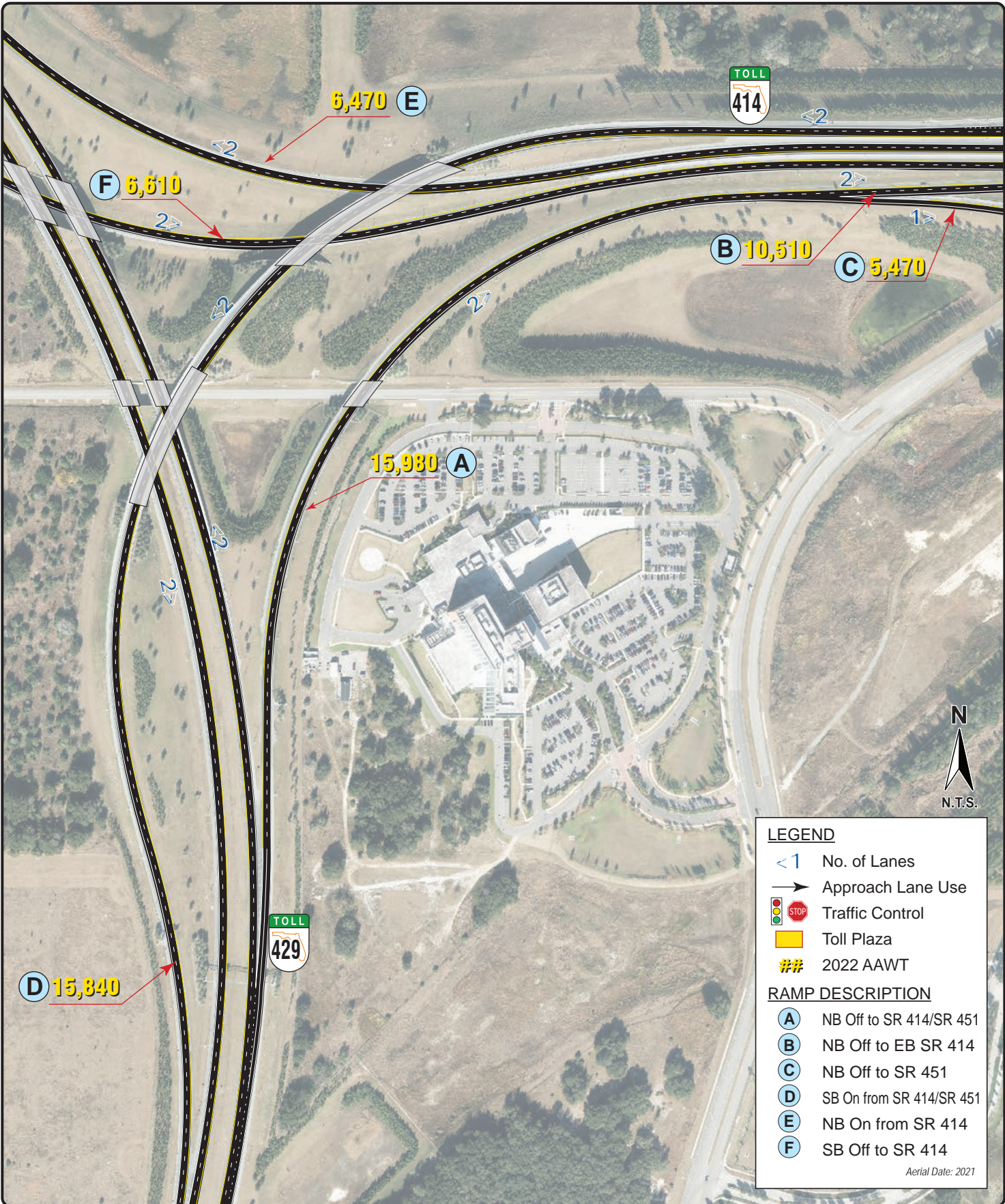

LEGEND

- <1> No. of Lanes
- Approach Lane Use
- 🚦 STOP Traffic Control
- 🟡 Toll Plaza
- ## 2022 AAWT

RAMP DESCRIPTION

- Ⓐ NB Off to SR 414/SR 451
- Ⓑ NB Off to EB SR 414
- Ⓒ NB Off to SR 451
- Ⓓ SB On from SR 414/SR 451
- Ⓔ NB On from SR 414
- Ⓕ SB Off to SR 414

Aerial Date: 2021



LEGEND

- <1> No. of Lanes
- ➔ Approach Lane Use
- 🚦 Traffic Control
- 🟡 Toll Plaza
- ## 2022 AAWT

RAMP DESCRIPTION

- Ⓐ NB Off Ramp
- Ⓑ SB On Ramp
- Ⓒ NB On Ramp
- Ⓓ SB Off Ramp

Aerial Date: 2021

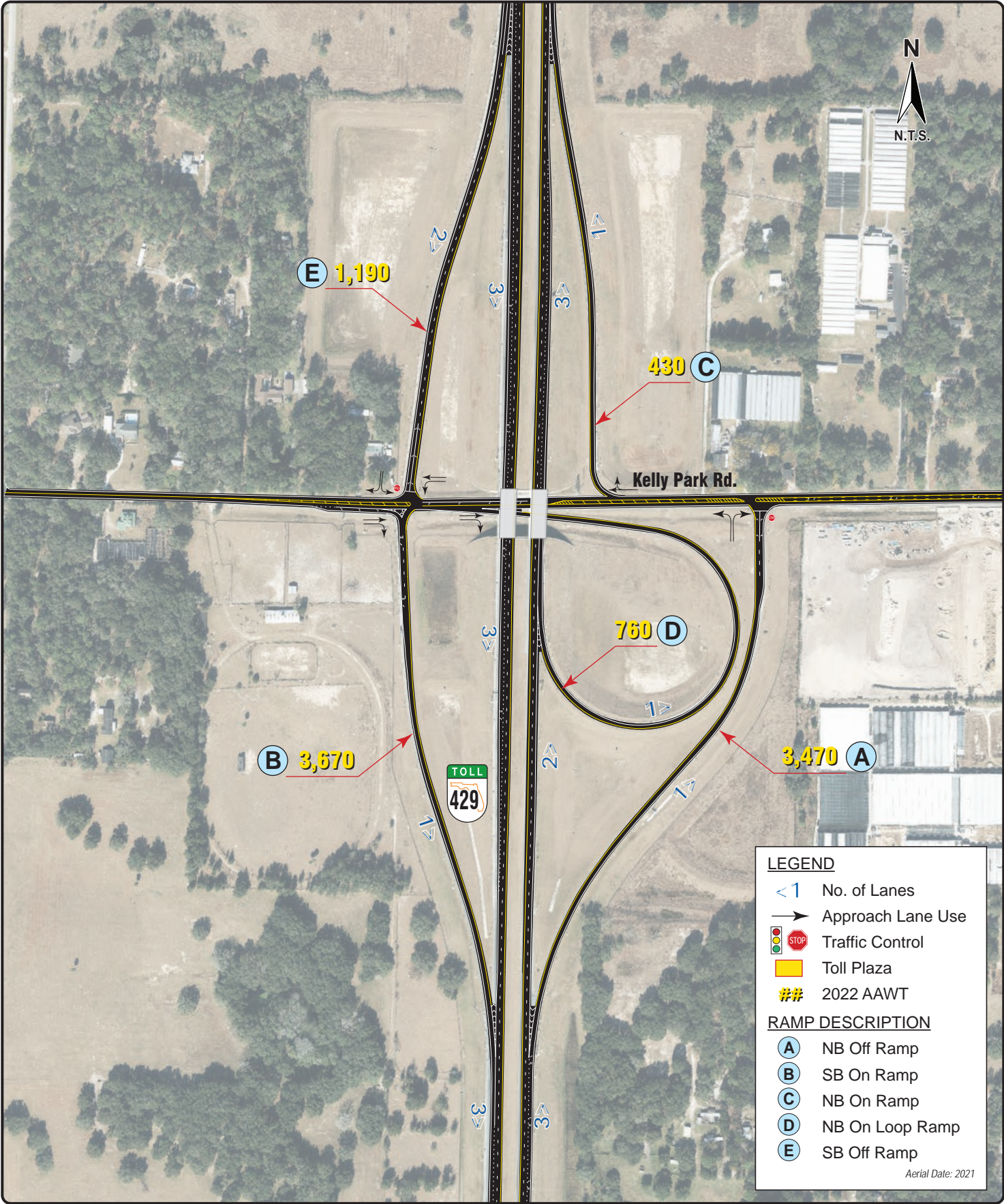

LEGEND

- < 1 No. of Lanes
- Approach Lane Use
- 🚦 STOP Traffic Control
- 🟡 Toll Plaza
- ## 2022 AAWT

RAMP DESCRIPTION

ⓐ	NB Off Ramp
ⓑ	SB On Ramp
ⓒ	NB On Ramp
ⓓ	NB On Loop Ramp
ⓔ	SB Off Ramp

Aerial Date: 2021

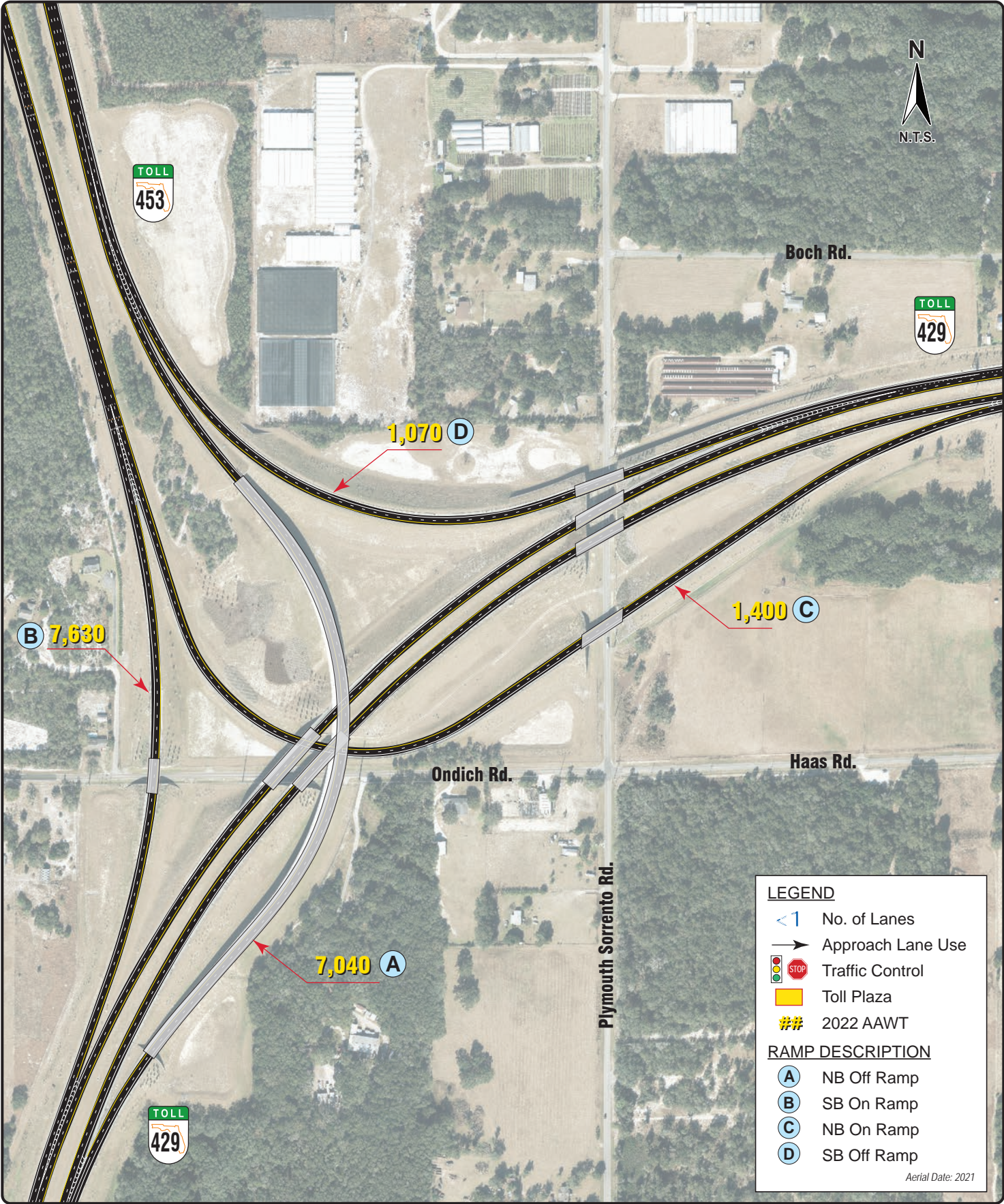

APOPKA EXPRESSWAY



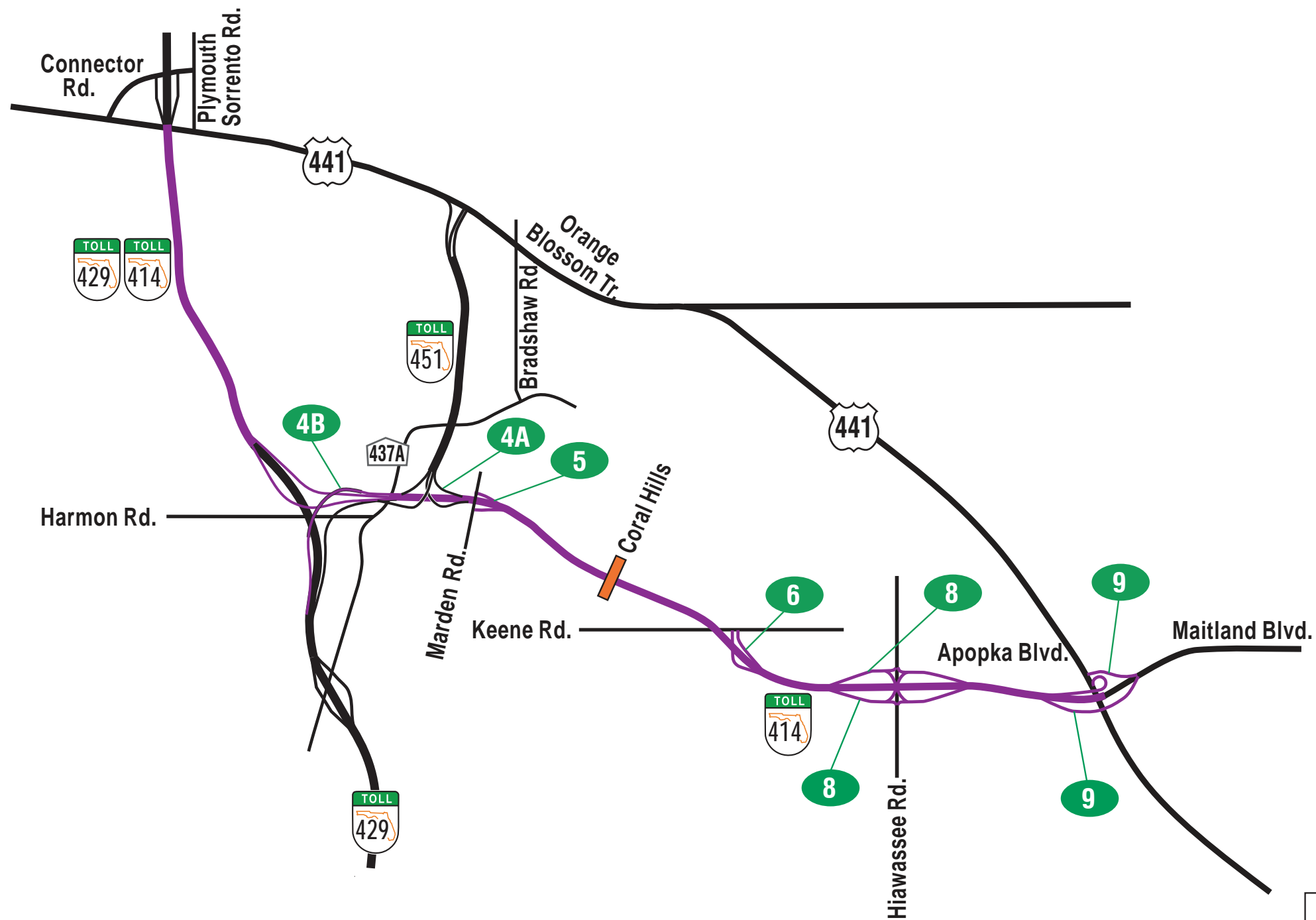



LEGEND

- Exit Number
- Existing SR 414
- Mainline Toll Plaza

LEGEND

- <1 No. of Lanes
- Approach Lane Use
-  Traffic Control
-  Toll Plaza
-  2022 AAWT

RAMP DESCRIPTION

- (A)** SB Off to EB SR 414
- (B)** WB On from SB SR 414
- (C)** NB On from SR 429
- (D)** SB Off to SR 429
- (E)** EB On from NB SR 429
- (F)** WB Off to SB SR 429

Aerial Date: 2021

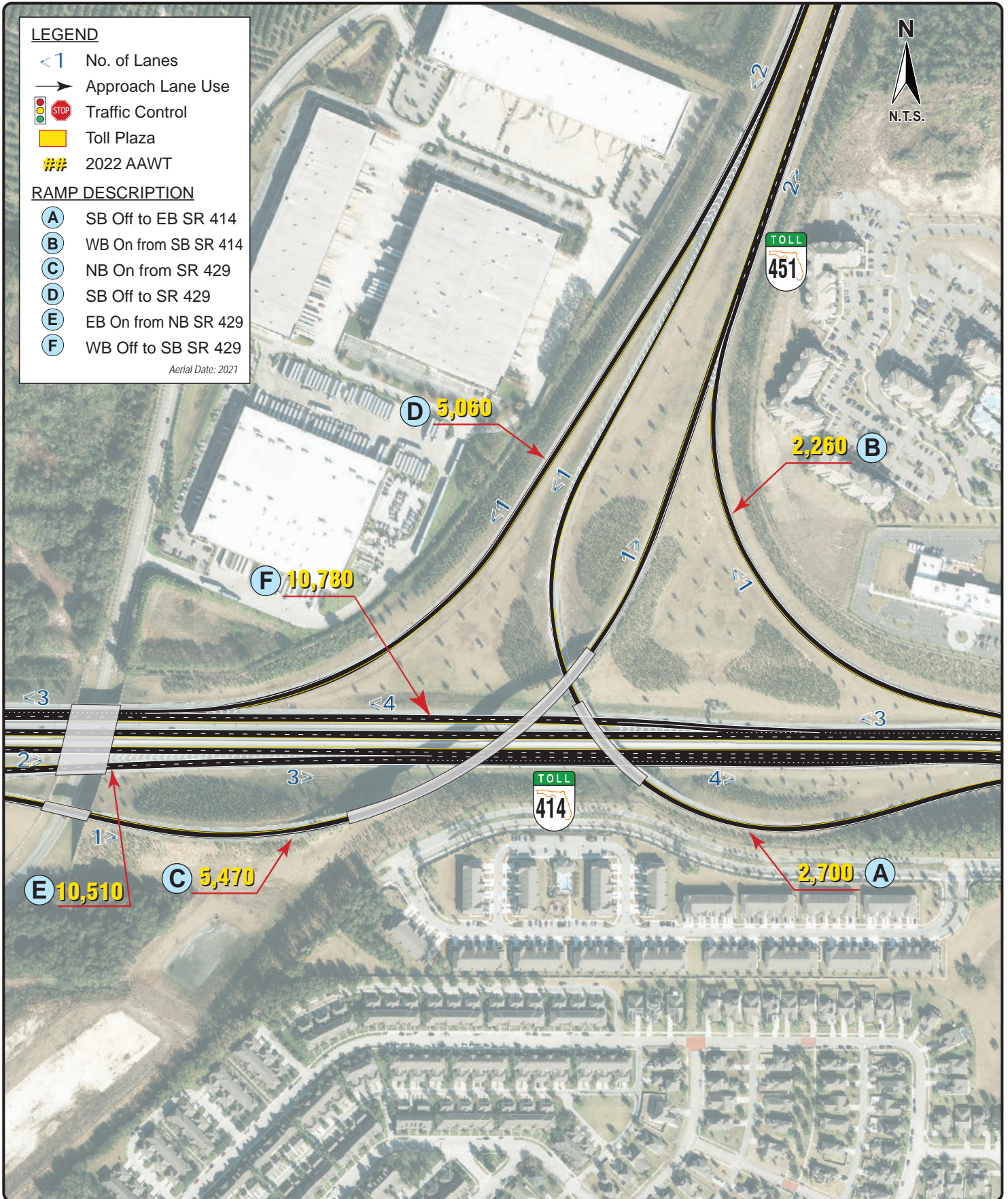

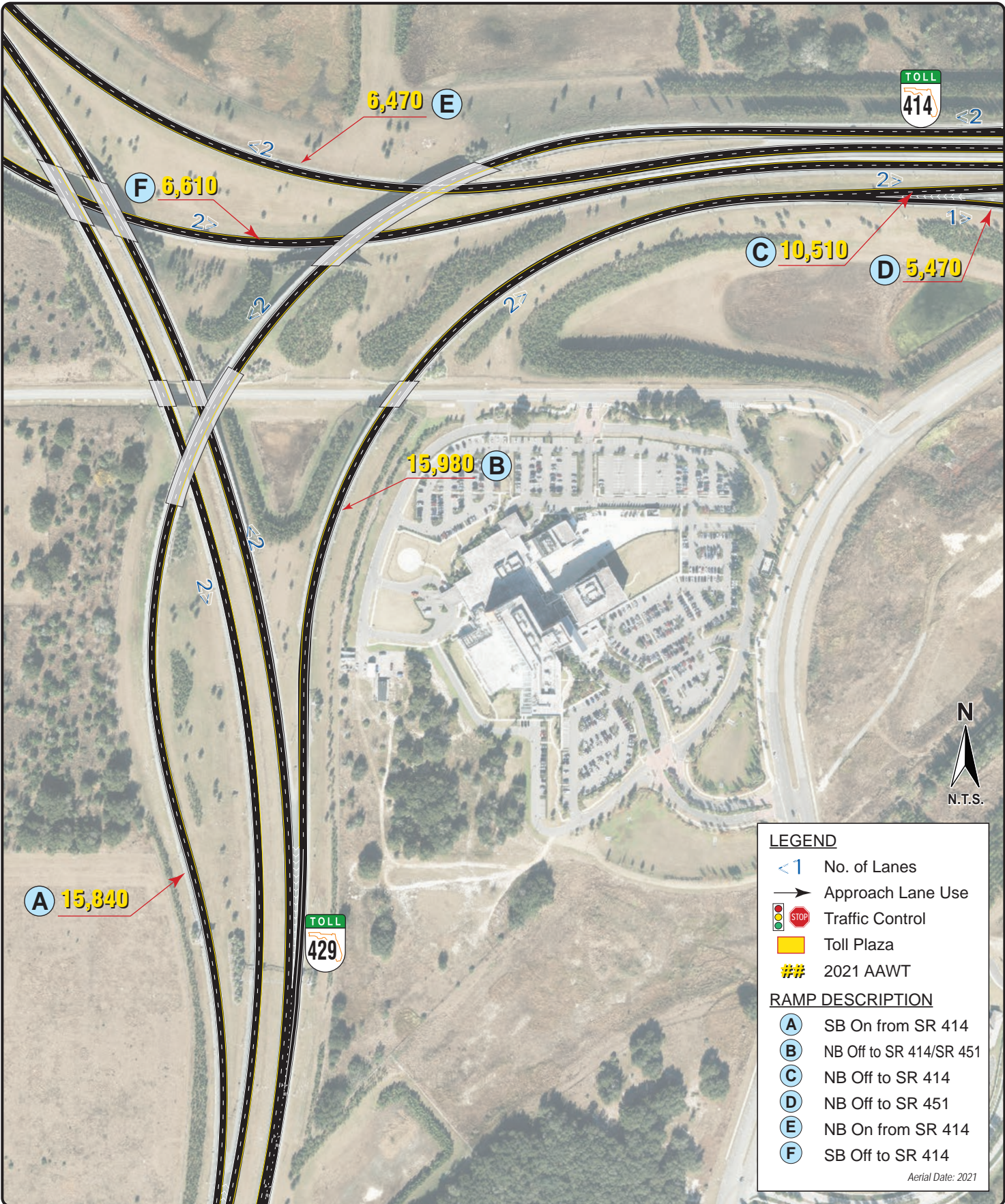

LEGEND

- <1 No. of Lanes
- Approach Lane Use
- STOP Traffic Control
- Yellow Box Toll Plaza
- ## 2021 AAWT

RAMP DESCRIPTION

- (A) SB On from SR 414
- (B) NB Off to SR 414/SR 451
- (C) NB Off to SR 414
- (D) NB Off to SR 451
- (E) NB On from SR 414
- (F) SB Off to SR 414

Aerial Date: 2021

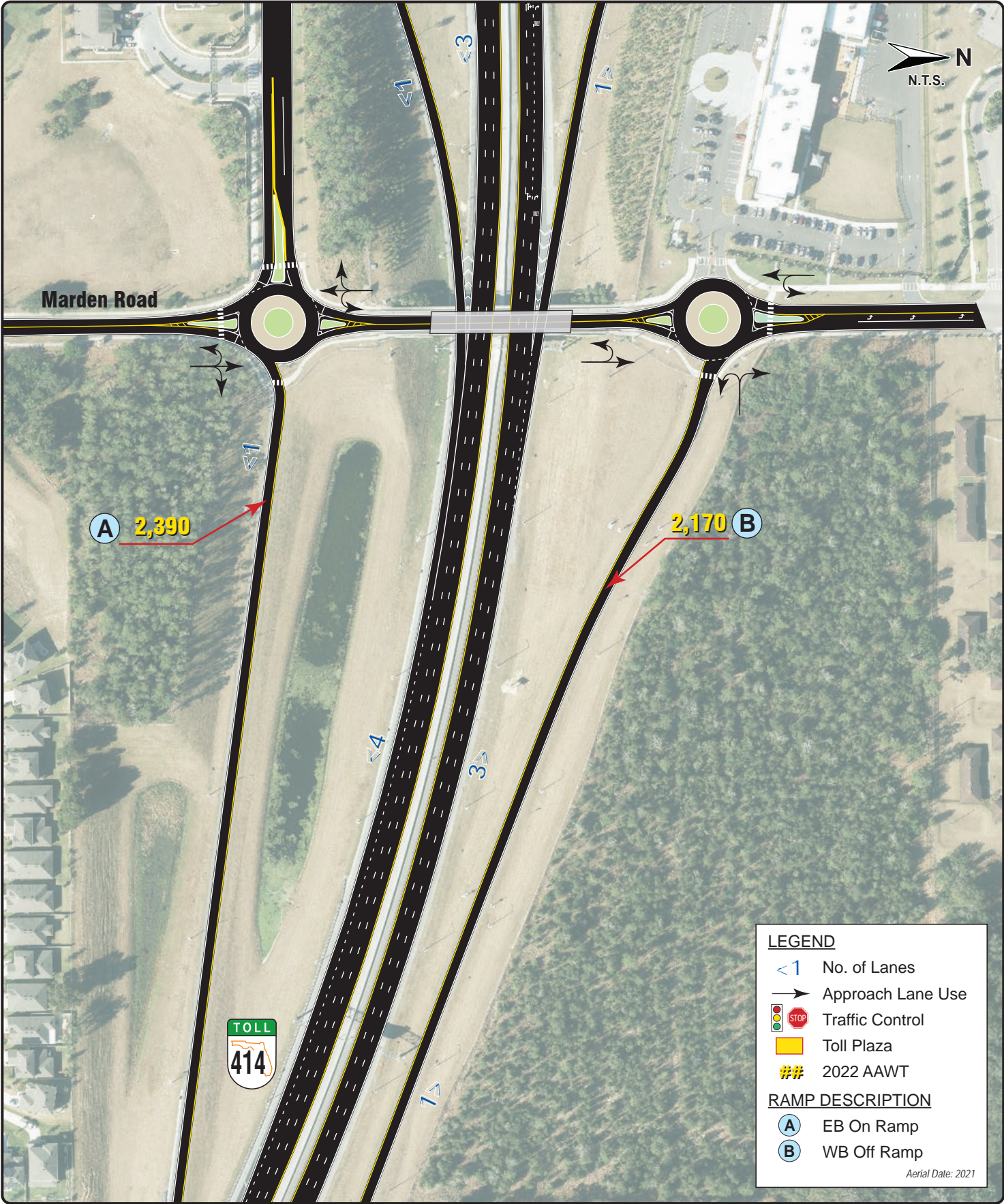

LEGEND

- <1 No. of Lanes
- Approach Lane Use
- ⚡ STOP Traffic Control
- Toll Plaza
- ## 2022 AAWT

RAMP DESCRIPTION

- Ⓐ EB On Ramp
- Ⓑ WB Off Ramp

Aerial Date: 2021

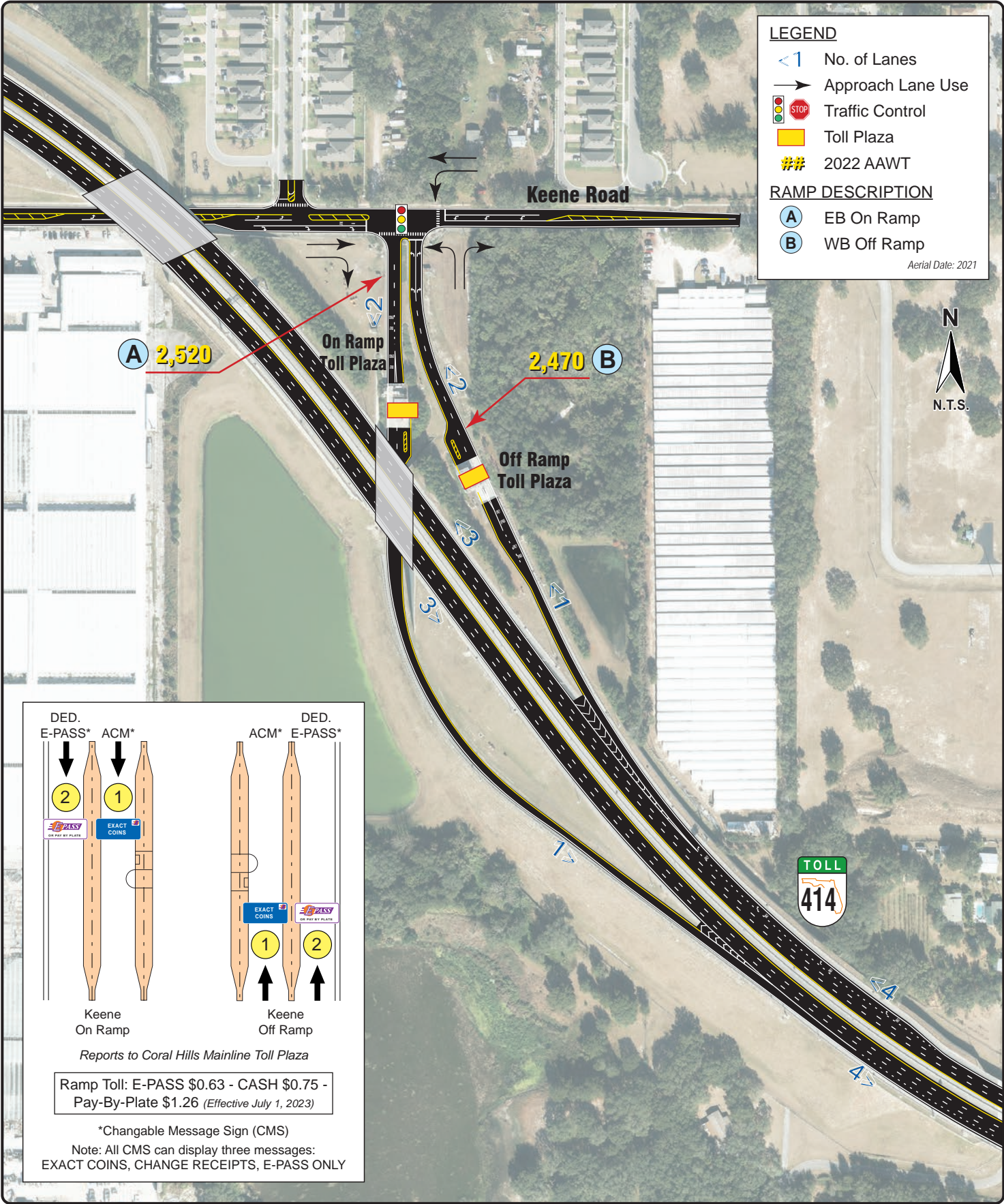

LEGEND

- No. of Lanes
- Approach Lane Use
- Traffic Control
- Toll Plaza
- 2022 AAWT

RAMP DESCRIPTION

- EB On Ramp
- WB Off Ramp

Aerial Date: 2021



DED. E-PASS*	ACM*	DED. E-PASS*	ACM*
Keene On Ramp		Keene Off Ramp	
Reports to Coral Hills Mainline Toll Plaza			
Ramp Toll: E-PASS \$0.63 - CASH \$0.75 - Pay-By-Plate \$1.26 (Effective July 1, 2023)			
*Changable Message Sign (CMS)			
Note: All CMS can display three messages: EXACT COINS, CHANGE RECEIPTS, E-PASS ONLY			

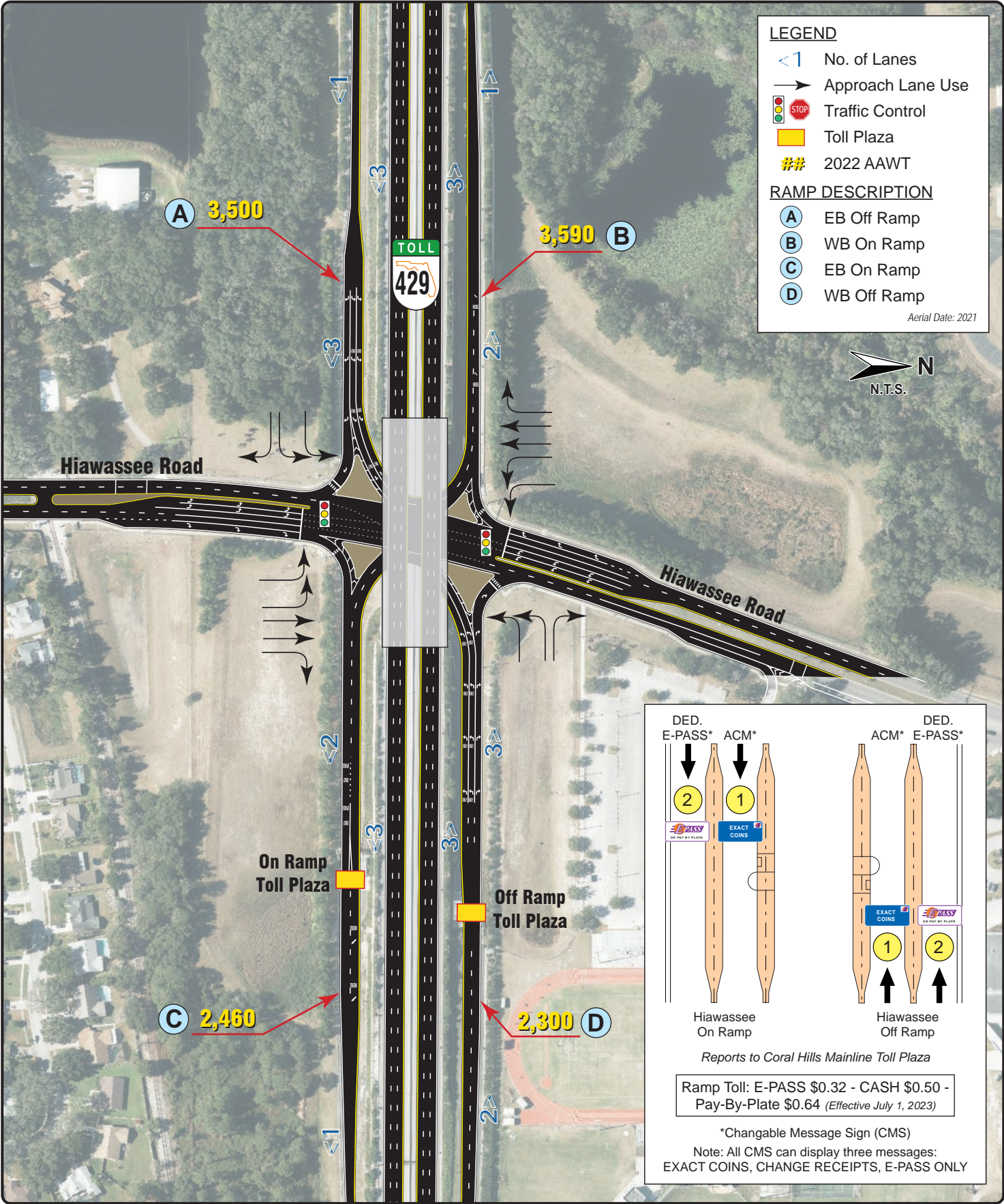

LEGEND

- < 1 No. of Lanes
- Approach Lane Use
- 🚦 STOP Traffic Control
- 🟡 Toll Plaza
- ## 2022 AAWT

RAMP DESCRIPTION

- Ⓐ EB Off Ramp
- Ⓑ WB On Ramp
- Ⓒ EB On Ramp
- Ⓓ WB Off Ramp

Aerial Date: 2021



DED. E-PASS*	ACM*	DED. ACM*	DED. E-PASS*
2	1	1	2
Hiwassee On Ramp	Hiwassee On Ramp	Hiwassee Off Ramp	Hiwassee Off Ramp

Reports to Coral Hills Mainline Toll Plaza

Ramp Toll: E-PASS \$0.32 - CASH \$0.50 - Pay-By-Plate \$0.64 (Effective July 1, 2023)

*Changable Message Sign (CMS)
 Note: All CMS can display three messages: EXACT COINS, CHANGE RECEIPTS, E-PASS ONLY

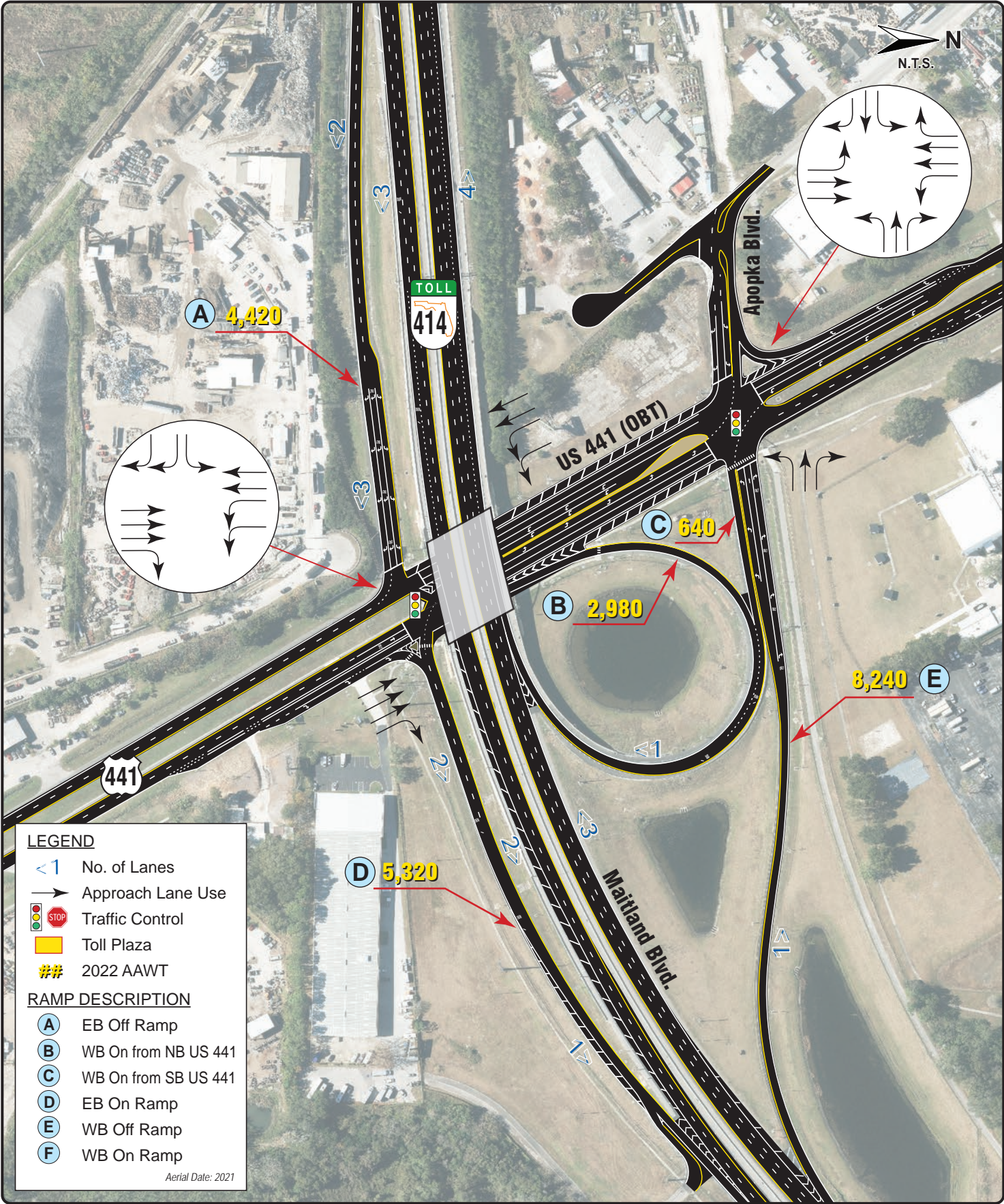

LEGEND

- < 1 No. of Lanes
- Approach Lane Use
- Traffic Control
- Toll Plaza
- ## 2022 AAWT

RAMP DESCRIPTION

- (A) EB Off Ramp
- (B) WB On from NB US 441
- (C) WB On from SB US 441
- (D) EB On Ramp
- (E) WB Off Ramp
- (F) WB On Ramp

Aerial Date: 2021

WESTERN BELTWAY CONNECTOR ROAD



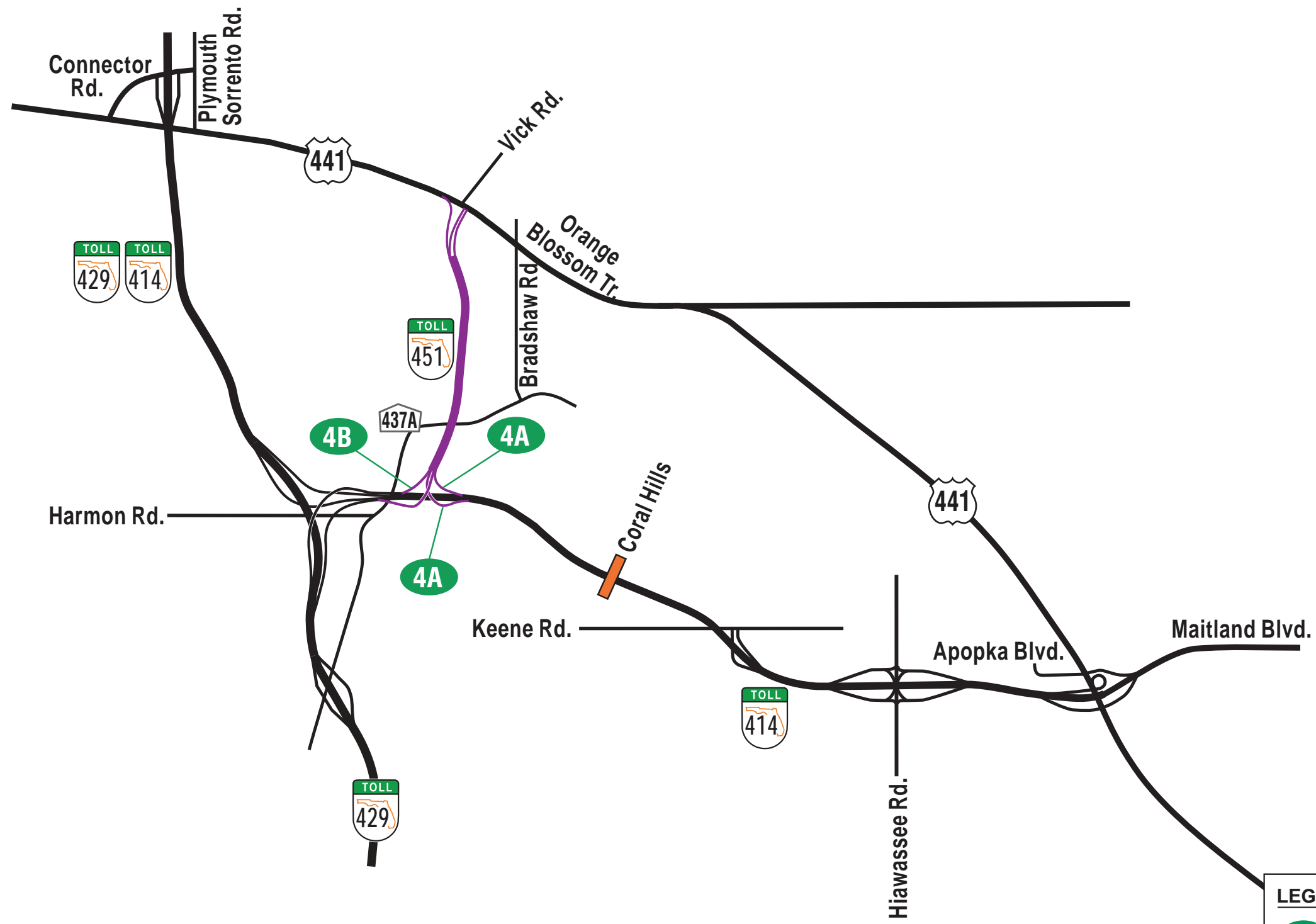



LEGEND

- Exit Number
- Existing SR 451
- Mainline Toll Plaza

LEGEND

- <1 No. of Lanes
- Approach Lane Use
-  Traffic Control
-  Toll Plaza
- ## 2022 AAWT

RAMP DESCRIPTION

- (A)** NB On from SR 429
- (B)** SB Off to SR 429
- (C)** NB On from WB SR 414
- (D)** SB Off to EB SR 414
- (E)** EB On from NB SR 429
- (F)** WB Off to SB SR 429

Aerial Date: 2021

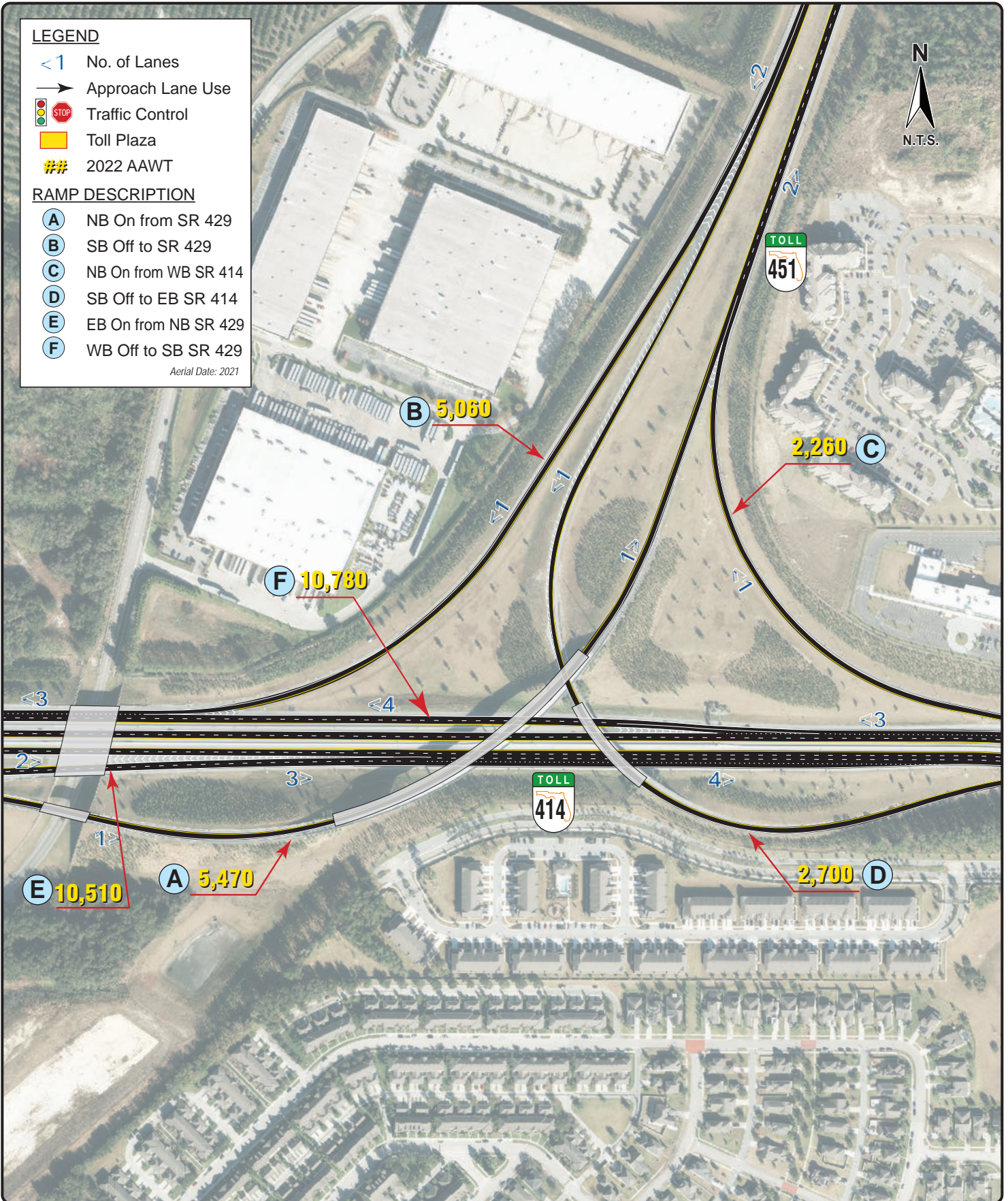

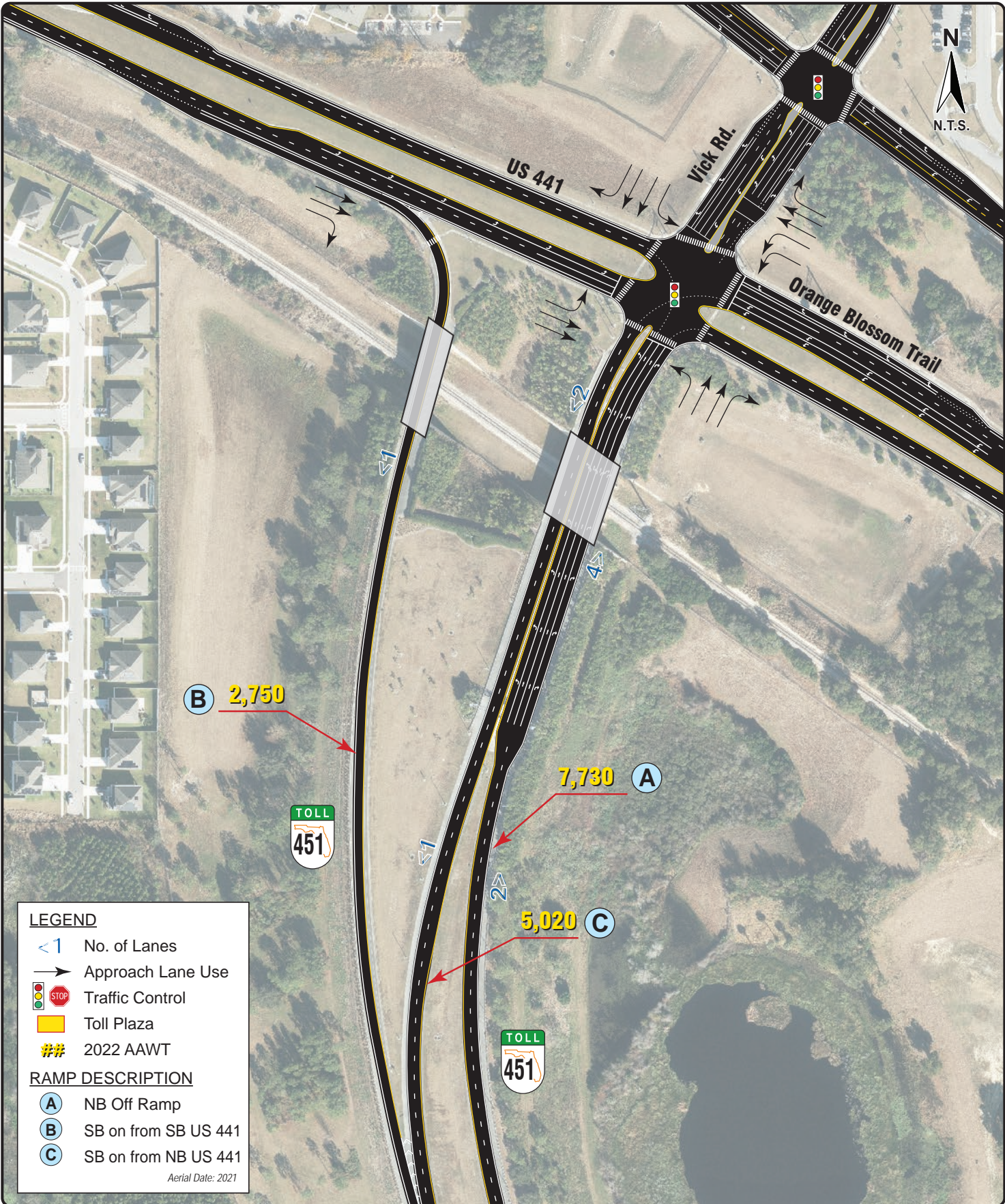

SR 453



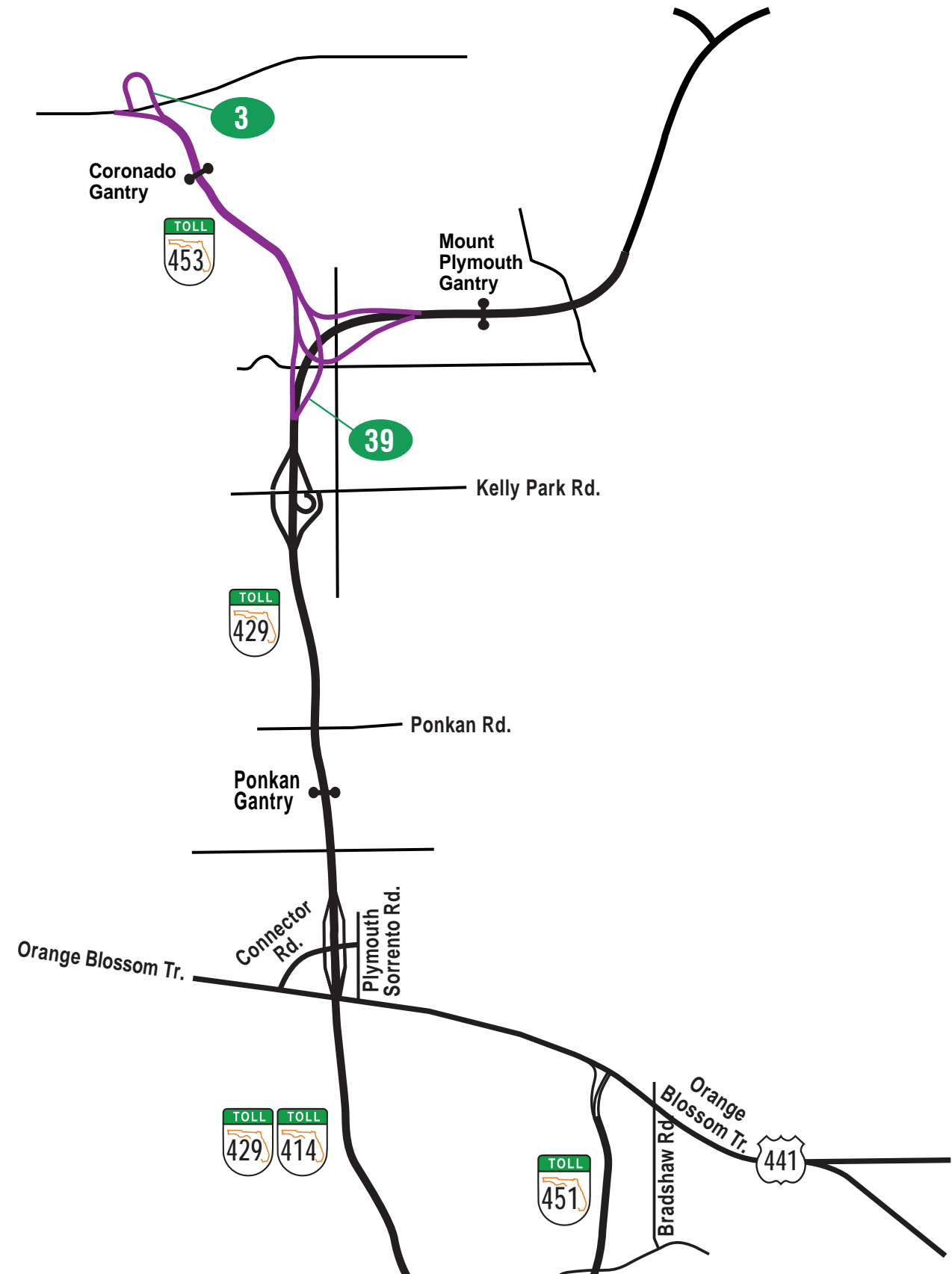

LEGEND

- Exit Number
- Existing SR 453
- Mainline Toll Plaza
- Mainline Toll Gantry

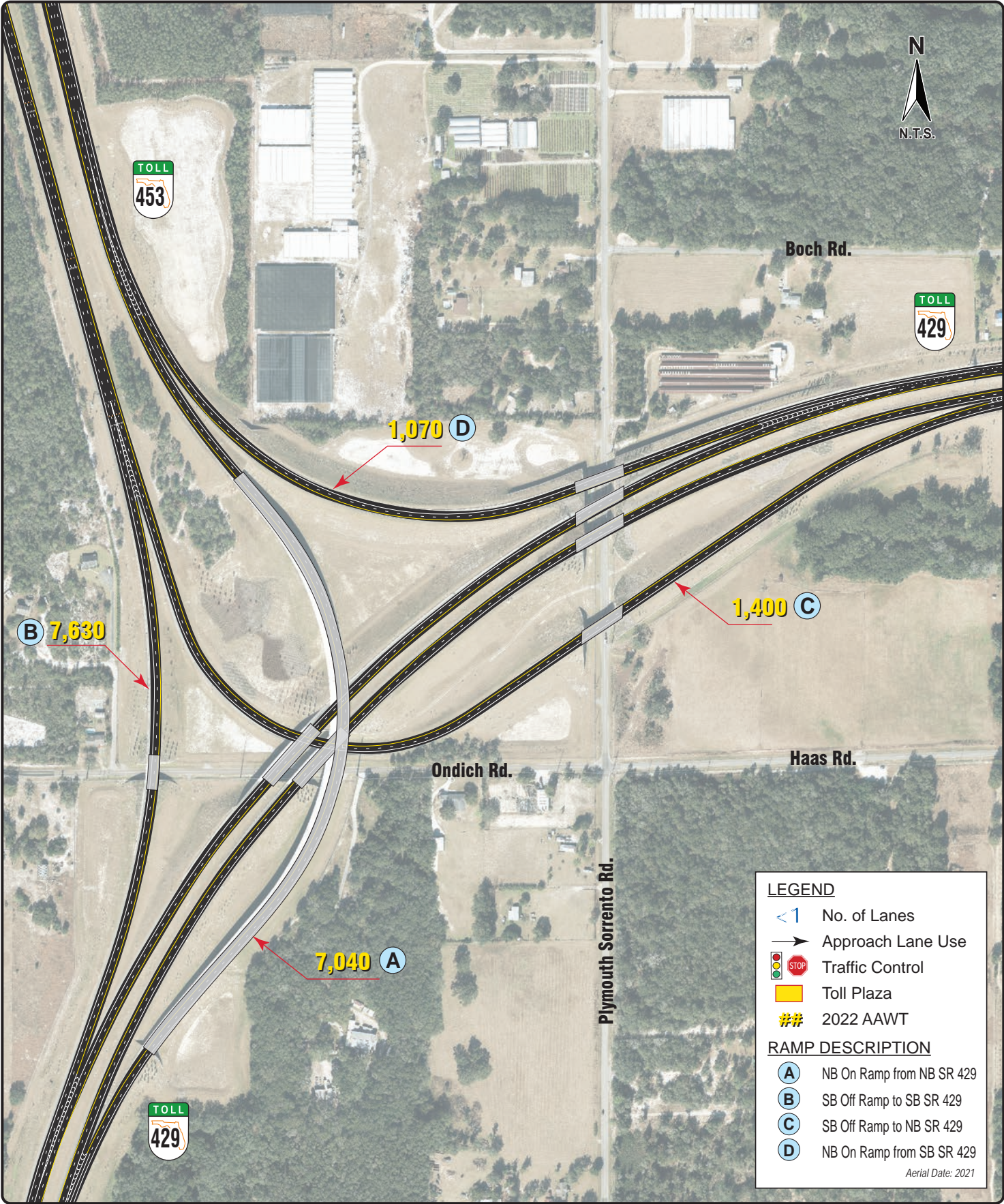

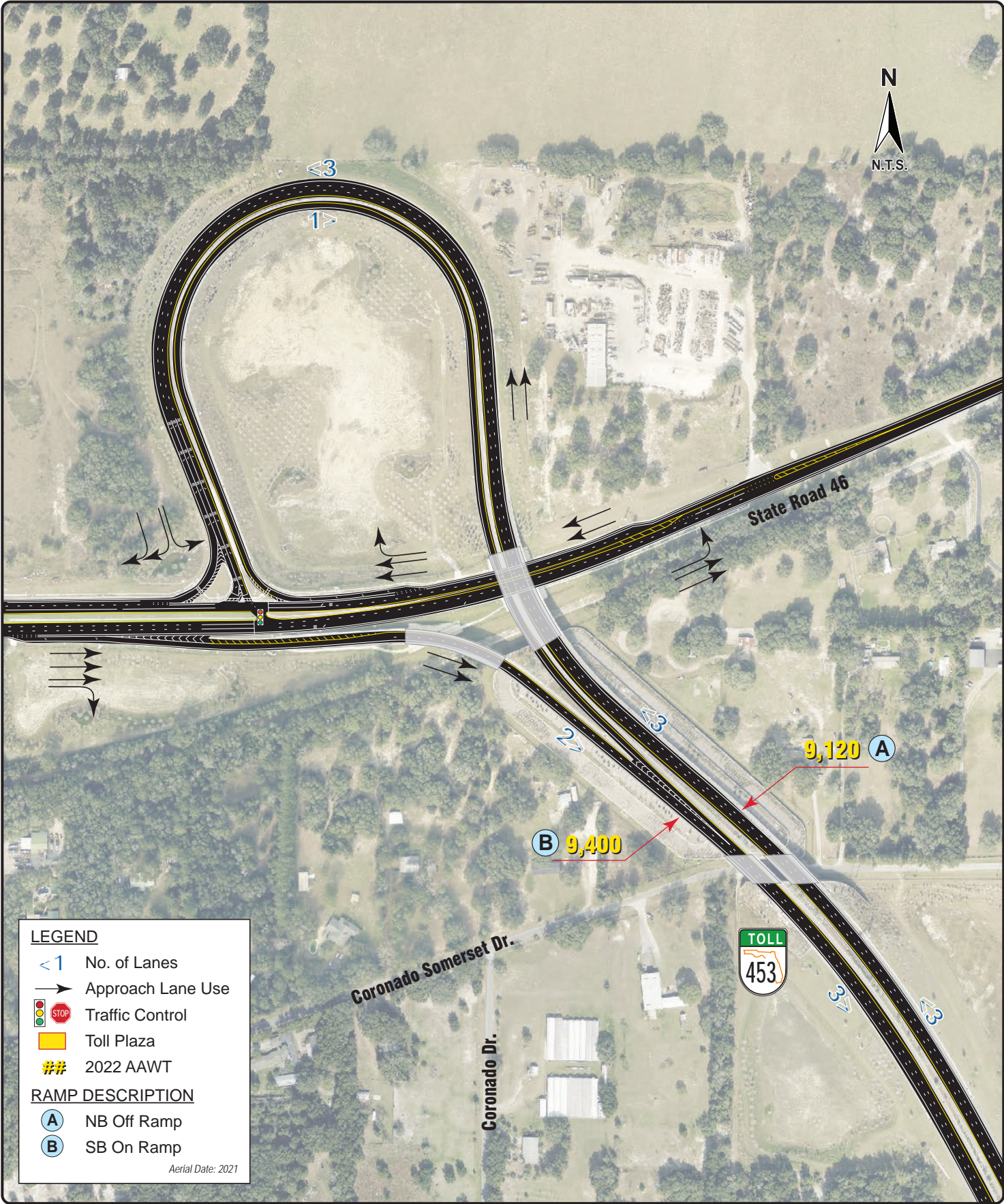

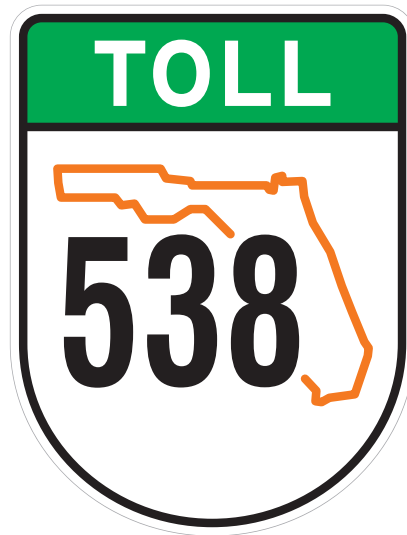

POINCIANA PARKWAY





LEGEND

-  Exit Number
-  Existing SR 538
-  Mainline Toll Gantry



B 3,490

3,770 A



E. Bourne Road

Marigold Avenue

LEGEND

- <1 No. of Lanes
- Approach Lane Use
- 🚦 STOP Traffic Control
- 🟡 Toll Plaza
- ## 2022 AAWT

RAMP DESCRIPTION

- Ⓐ NB On Ramp
- Ⓑ SB Off Ramp

Aerial Date: 2021

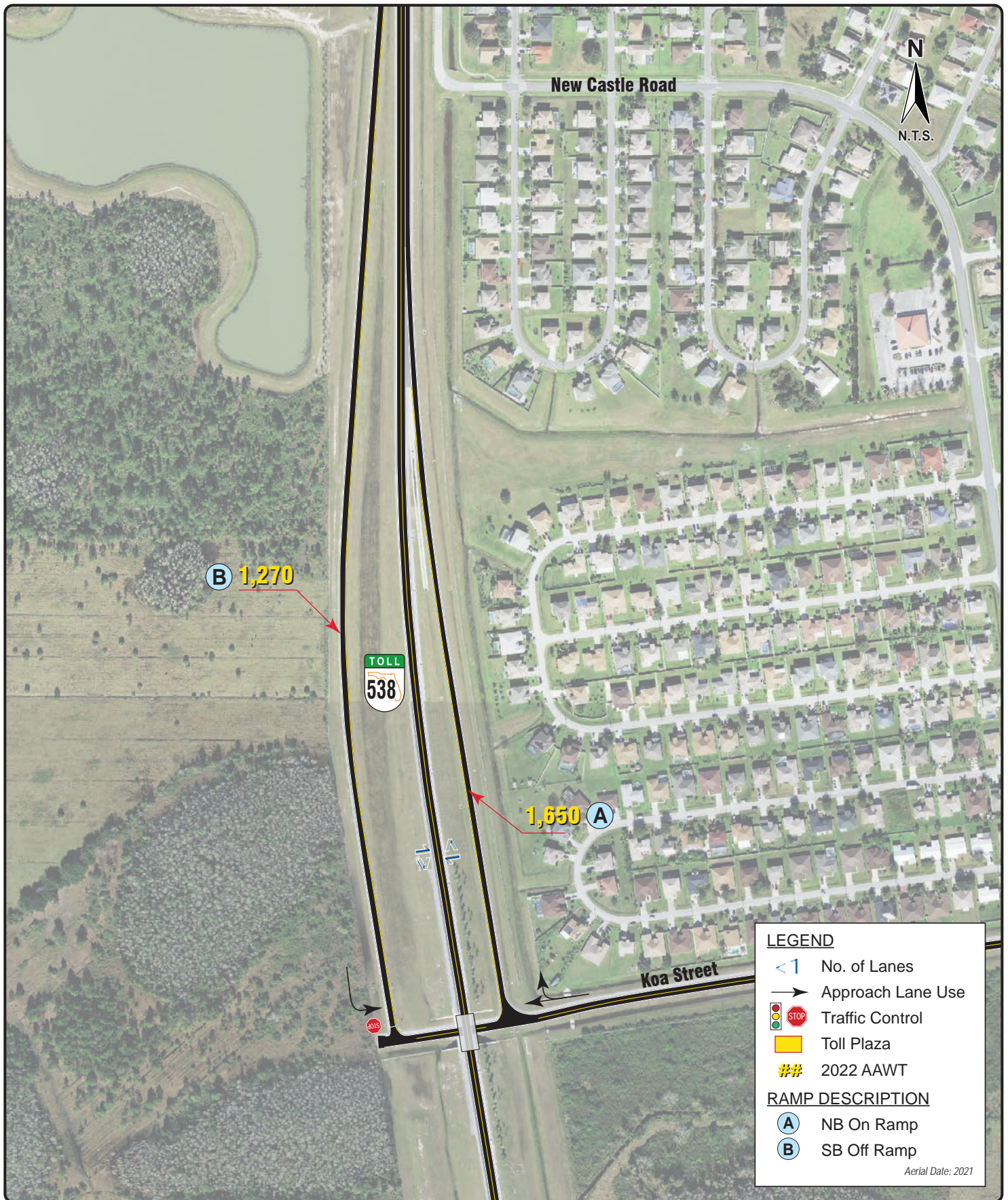

LEGEND

- < 1 No. of Lanes
- Approach Lane Use
- ⬆️ ⬆️ ⬆️ STOP Traffic Control
- 🟡 Toll Plaza
- ## 2022 AAWT

RAMP DESCRIPTION

- Ⓐ NB On Ramp
- Ⓑ SB Off Ramp

Aerial Date: 2021



SECTION V: General Statistics

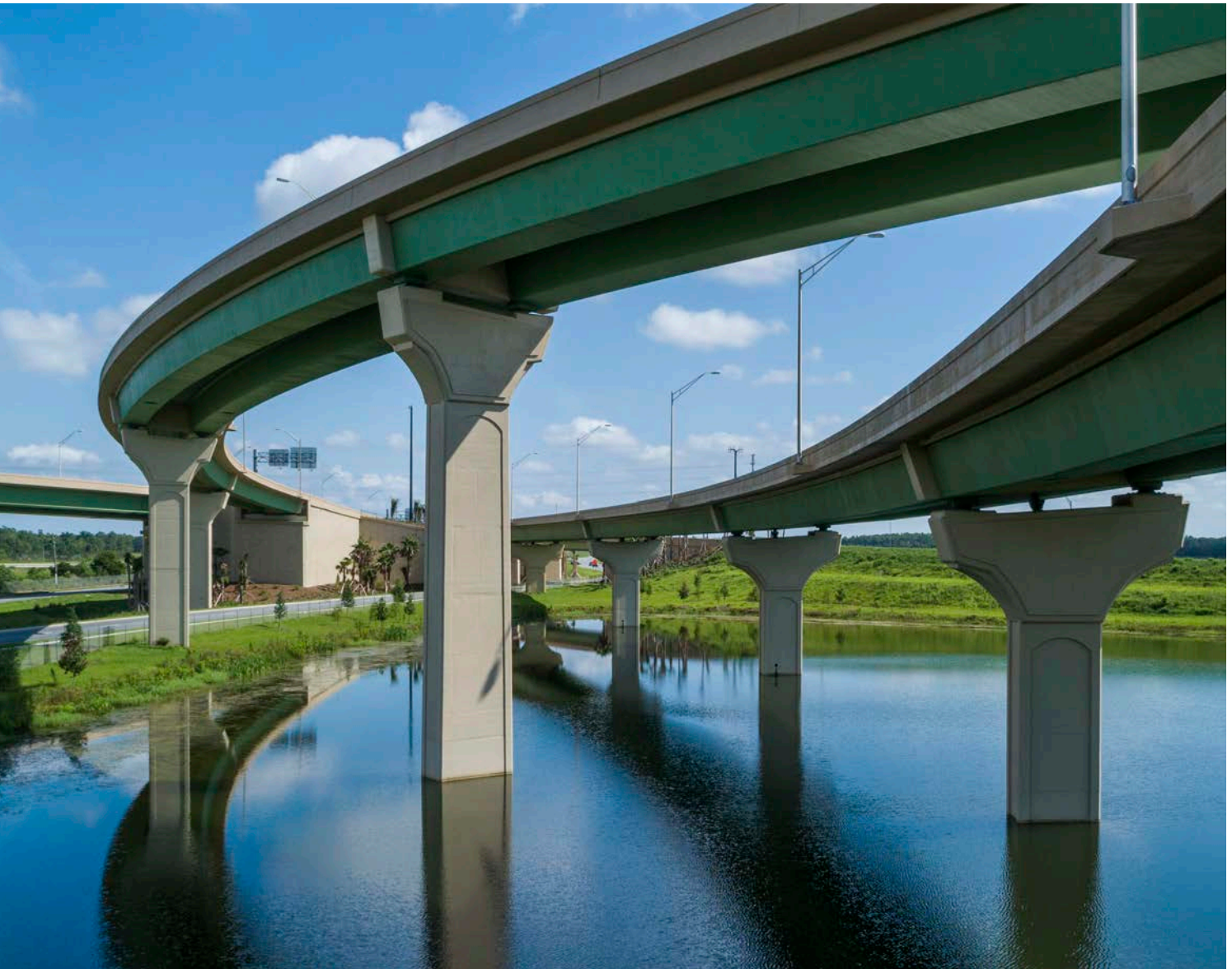

2022 Traffic Data and Statistics Manual
CENTRAL FLORIDA EXPRESSWAY AUTHORITY

General Statistics

This section of the manual is a summary of the general statistics of the Central Florida Expressway Authority's expressway system. Data is included for SR 408 (East-West Expressway), SR 528 (Beachline Expressway), SR 417 (Central Florida GreeneWay), SR 429 (Daniel Webster Western Beltway and Wekiva Parkway), SR 451 (Western Connector), SR 414 (Apopka Expressway), SR 453, SR 538 (Poinciana Parkway) and the non-system Goldenrod Extension.

The information contained in this section is shown below:

- Expressway Total Centerline Mileage and Total Lane Miles for SR 408, SR 528, SR 417, SR 429, SR 451, SR 414, SR 453, SR 538 and the Goldenrod Extension.
- Toll Facility Lane Summary for SR 408, SR 528, SR 417, SR 429, SR 414, SR 453, SR 538 and the Goldenrod Extension.
- Toll Rate Schedule for all mainline and ramp toll facilities based on the number of axles.
- Distance between interchanges for SR 408, SR 528, SR 417, SR 429, SR 414, SR 453 and SR 538 (Centerline of Crossroad to Centerline of Crossroad).
- Toll Rates and/or Toll Costs between interchanges on SR 408, SR 528, SR 417, SR 429, SR 414, SR 453 and SR 538.
- Toll Cost per Mile between interchanges on SR 408, SR 528, SR 417, SR 429, SR 414, SR 453 and SR 538.

Expressway Mileage, Lane Miles, Toll Facility Lanes and Toll Rate Schedules



2022 Traffic Data and Statistics Manual
CENTRAL FLORIDA EXPRESSWAY AUTHORITY

Central Florida Expressway Authority (CFX)

Expressway Mileage (as of December 31, 2022)

CFX Expressway Facility	Rounded Miles	Total Length ⁽¹⁾	
		Miles	Kilometers
Central Florida Expressway System			
SR 408 (East-West Expressway)	22	21.477	34.564
SR 528 (Beachline Expressway)	23	22.405	36.057
SR 417 (Central Florida GreeneWay)	32	31.613	50.876
SR 429 (Western Beltway and Wekiva Parkway)	31	30.848	49.645
SR 451 (Western Beltway Connector Road)	2	1.670	2.688
SR 414 (Apopka Expressway)	6	6.024	9.695
SR 453	2	1.983	3.191
SR 538 (Poinciana Parkway)	7	7.194	11.578
Total CFX System	125	123.214	198.294
Central Florida Expressway Non-system			
Goldenrod Extension ⁽⁴⁾	2	1.970	3.170

Total Lane Miles (as of December 31, 2022)

CFX Expressway Facility	Lane Mile Summary	
	Mainline	Ramps
Central Florida Expressway System		
SR 408 (East-West Expressway)	174.586	44.005
SR 528 (Beachline Expressway)	120.985	21.817
SR 417 (Central Florida GreeneWay)	183.620	53.880
SR 429 (Western Beltway and Wekiva Parkway)	143.393	34.701
SR 451 (Western Beltway Connector Road)	7.172	0.403
SR 414 (Apopka Expressway)	40.954	17.142
SR 453	7.617	3.420
SR 538 (Poinciana Parkway)	14.913	1.549
Total CFX System	693.240	176.917
Central Florida Expressway Non-system		
Goldenrod Extension ⁽⁴⁾	9.590	0.000

Notes:

1. Measured along the centerline of the expressway facilities.
2. SR 429 Western Beltway includes Wekiva Parkway Phase II (Completed March 2018). Shown for informational purposes only.
3. SR 538 (Poinciana Parkway) became a CFX system facility in December 2019.
4. Goldenrod Extension is not considered part of the CFX system. Shown for informational purposes only.

Central Florida Expressway Authority (CFX)

Toll Facilities Lane Summary (as of December 31, 2022)

CFX Expressway Facility	Number of Tolled Lanes
SR 408 (East-West Expressway)	
Hiwassee Mainline Toll Facility	14
Good Homes Road Ramp Toll Facilities	4
Hiwassee Road Ramp Toll Facilities	4
SUBTOTAL	22
Pine Hills Mainline Toll Facility	14
Old Winter Garden/Ortman Drive Ramp Toll Facilities	4
John Young Ramp Toll Facilities	4
Orange Blossom Trail Ramp Toll Facilities	4
SUBTOTAL	26
Conway East and West Mainline Toll Facilities	19
Mills Avenue Ramp Toll Facilities	1
Bumby Avenue Ramp Toll Facilities	4
Conway Road Ramp Toll Facilities	4
Andes Avenue - To SR 436 Ramp Toll Facilities	2
SR 436 (Semoran Boulevard) Ramp Toll Facilities	2
Yucatan Drive/SR 436 Ramp Toll Facilities	2
SUBTOTAL	34
Dean Mainline Toll Facility	14
Dean Road Ramp Toll Facilities	4
Rouse Road Ramp Toll Facilities	4
SUBTOTAL	22
SR 408 TOTAL	104
SR 528 (Beachline Expressway)	
Airport Mainline Toll Facility	0
Boggy Creek Road/McCoy Road	6
Conway Road/Tradeport Drive	4
SUBTOTAL	10
Beachline Mainline Toll Plaza	12
Innovation Way Ramp Toll Facilities	4
SUB-TOTAL	16

Notes:

1. SR 538 (Poinciana Parkway) became a CFX system project in December 2019.
2. SR 429 / Stoneybrook West Parkway Interchange opened to traffic in November 2020.
3. Goldenrod Extension is not considered part of the CFX system. Shown for informational purposes only.

Central Florida Expressway Authority (CFX)

Toll Facilities Lane Summary (as of December 31, 2022) - Continued

CFX Expressway Facility	Number of Toll Lanes and Equipment
SR 528 (Beachline Expressway) - continued	
Dallas Mainline Toll Facility	12
Dallas Boulevard Ramp Toll Facilities	4
SUBTOTAL	16
SR 528 TOTAL	42
SR 417 (Central Florida GreeneWay)	
John Young Mainline Toll Facility	12
John Young Parkway Ramp Toll Facilities	4
Orange Blossom Trail Ramp Toll Facilities	4
Landstar Boulevard Ramp Toll Facilities	4
SUBTOTAL	24
Boggy Creek Mainline Toll Facility	14
South Access Road Ramp Toll Facility and Gantry	3
Boggy Creek Road Ramp Toll Facilities	4
Lake Nona Boulevard Ramp Toll Facilities	4
Narcoossee Road Ramp Toll Facilities	4
Moss Park Road Ramp Toll Facilities	4
Dowden Road Ramp Toll Facilities	4
SUBTOTAL	37
Curry Ford Mainline Toll Facility	14
Lee Vista Boulevard Ramp Toll Facilities	4
Curry Ford Road Ramp Toll Facilities	4
SUBTOTAL	22
University Mainline Toll Facility	12
SR 50/Colonial Drive Ramp Toll Facilities	4
University Boulevard Ramp Toll Facilities	4
SUBTOTAL	20
SR 417 TOTAL	103

Notes:

1. SR 538 (Poinciana Parkway) became a CFX system project in December 2019.
2. SR 429 / Stoneybrook West Parkway Interchange opened to traffic in November 2020.
3. Goldenrod Extension is not considered part of the CFX system. Shown for informational purposes only.

Central Florida Expressway Authority (CFX)

Toll Facilities Lane Summary (as of December 31, 2022) - Continued

CFX Expressway Facility	Number of Toll Lanes and Equipment
SR 429 (Western Expressway and Wekiva Parkway)	
Independence Mainline Toll Facility	10
Schofield Road Ramp Facilities	4
New Independence Parkway Ramp Toll Facilities	4
Stoneybrook West Parkway Ramp Toll Gantry Facilities ⁽²⁾	2
CR 535 (Winter Garden Vineland Road) Ramp Toll Facilities ⁽²⁾	5
SUBTOTAL	25
Forest Lake Mainline Toll Facility	10
Plant Street/Franklin Street/SR 438 Ramp Toll Facilities	4
West Road Ramp Toll Facilities	4
CR 437A (Ocoee-Apopka Road) Ramp Toll Facilities	4
SUBTOTAL	22
Ponkan Mainline Toll Gantry Facilities	4
Mount Plymouth Mainline Toll Gantry Facilities	4
SUBTOTAL	8
SR 429 TOTAL	55
SR 414 (Apopka Expressway)	
Coral Hills Mainline Toll Facility	12
Keene Road Ramp Toll Facilities	4
Hiawassee Road Ramp Toll Facilities	4
SUBTOTAL	20
SR 414 TOTAL	20
SR 453	
Coronado Mainline Toll Facility	4
SR 453 TOTAL	4
SR 538 (Poinciana Parkway) ⁽¹⁾	
Marigold Mainline Toll Gantry Facilities	2
Koa Mainline Toll Gantry Facilities	2
SR 538 TOTAL	4
SYSTEM GRAND TOTAL	332
SR 551 (Goldenrod Extension) ⁽³⁾	
Goldenrod Mainline Toll Facility	6

Notes:

1. SR 538 (Poinciana Parkway) became a CFX system project in December 2019.
2. SR 429 / Stoneybrook West Parkway Interchange opened to traffic in November 2020.
3. Goldenrod Extension is not considered part of the CFX system. Shown for informational purposes only.

CFX Expressway	Motorcycle & 2 Axles			3 Axles			4 Axles			5 or More Axles		
	E-PASS	CASH	Pay-By-Plate ⁽⁴⁾	E-PASS	CASH	Pay-By-Plate ⁽⁴⁾	E-PASS	CASH	Pay-By-Plate ⁽⁴⁾	E-PASS	CASH	Pay-By-Plate ⁽⁴⁾
SR 408 (East-West Expressway)												
Hiawassee Mainline Toll Facility	\$0.93	\$1.25	\$1.86	\$1.89	\$2.25	\$3.78	\$2.18	\$2.50	\$4.36	\$2.82	\$3.25	\$5.64
Good Homes Road	\$0.28	\$0.50	\$0.56	\$0.28	\$0.50	\$0.56	\$0.28	\$0.50	\$0.56	\$0.28	\$0.50	\$0.56
Hiawassee Road	\$0.63	\$0.75	\$1.26	\$0.63	\$0.75	\$1.26	\$0.63	\$0.75	\$1.26	\$0.63	\$0.75	\$1.26
Pine Hills Mainline Toll Facility	\$1.25	\$1.50	\$2.50	\$1.89	\$2.25	\$3.78	\$2.18	\$2.50	\$4.36	\$2.82	\$3.25	\$5.64
Old Winter Garden Road/ Ortman Drive	\$0.93	\$1.25	\$1.86	\$0.93	\$1.25	\$1.86	\$0.93	\$1.25	\$1.86	\$0.93	\$1.25	\$1.86
John Young Parkway	\$0.93	\$1.25	\$1.86	\$0.93	\$1.25	\$1.86	\$0.93	\$1.25	\$1.86	\$0.93	\$1.25	\$1.86
Orange Blossom Trail	\$0.63	\$0.75	\$1.26	\$0.63	\$0.75	\$1.26	\$0.63	\$0.75	\$1.26	\$0.63	\$0.75	\$1.26
Mills Avenue	\$0.63	\$0.75	\$1.26	\$0.63	\$0.75	\$1.26	\$0.63	\$0.75	\$1.26	\$0.63	\$0.75	\$1.26
Conway East-West Mainline Toll Facility	\$1.25	\$1.50	\$2.50	\$1.89	\$2.25	\$3.78	\$2.18	\$2.50	\$4.36	\$2.82	\$3.25	\$5.64
Bumby Avenue	\$0.63	\$0.75	\$1.26	\$0.63	\$0.75	\$1.26	\$0.63	\$0.75	\$1.26	\$0.63	\$0.75	\$1.26
Conway Road	\$0.93	\$1.25	\$1.86	\$0.93	\$1.25	\$1.86	\$0.93	\$1.25	\$1.86	\$0.93	\$1.25	\$1.86
Andes Avenue/SR 436 (Semoran Boulevard)	\$1.25	\$1.50	\$2.50	\$1.25	\$1.50	\$2.50	\$1.25	\$1.50	\$2.50	\$1.25	\$1.50	\$2.50
SR 436 (Semoran Boulevard)/Yucatan Drive	\$0.93	\$1.25	\$1.86	\$0.93	\$1.25	\$1.86	\$0.93	\$1.25	\$1.86	\$0.93	\$1.25	\$1.86
Dean Mainline Toll Facility	\$0.93	\$1.25	\$1.86	\$1.89	\$2.25	\$3.78	\$2.18	\$2.50	\$4.36	\$2.82	\$3.25	\$5.64
Dean Road	\$0.63	\$0.75	\$1.26	\$0.63	\$0.75	\$1.26	\$0.63	\$0.75	\$1.26	\$0.63	\$0.75	\$1.26
Rouse Road	\$0.63	\$0.75	\$1.26	\$0.63	\$0.75	\$1.26	\$0.63	\$0.75	\$1.26	\$0.63	\$0.75	\$1.26
SR 528 (Beachline Expressway)												
Boggy Creek Road/McCoy Road	\$1.25	\$1.50	\$2.50	\$1.25	\$1.50	\$2.50	\$1.25	\$1.50	\$2.50	\$1.25	\$1.50	\$2.50
Conway Road/Tradeport Drive	\$1.25	\$1.50	\$2.50	\$1.25	\$1.50	\$2.50	\$1.25	\$1.50	\$2.50	\$1.25	\$1.50	\$2.50
Beachline Mainline Toll Facility ⁽¹⁾	\$0.99	\$1.25	\$1.98	\$1.97	\$2.25	\$3.94	\$2.29	\$2.75	\$4.58	\$2.92	\$3.25	\$5.84
Innovation Way	\$0.67	\$0.75	\$1.34	\$0.67	\$0.75	\$1.34	\$0.67	\$0.75	\$1.34	\$0.67	\$0.75	\$1.34
Dallas Mainline Toll Facility ⁽²⁾	\$0.86	\$1.75	\$2.16	\$1.14	\$2.00	\$2.72	\$1.43	\$2.50	\$3.30	\$1.43	\$2.50	\$3.30
Dallas Boulevard	\$0.58	\$0.75	\$1.16	\$0.58	\$0.75	\$1.16	\$0.58	\$0.75	\$1.16	\$0.58	\$0.75	\$1.16
SR 417 (Central Florida GreeneWay)												
John Young Mainline Toll Facility	\$1.56	\$1.75	\$3.12	\$2.18	\$2.50	\$4.36	\$2.82	\$3.25	\$5.64	\$3.44	\$4.00	\$6.88
John Young Parkway	\$0.93	\$1.25	\$1.86	\$0.93	\$1.25	\$1.86	\$0.93	\$1.25	\$1.86	\$0.93	\$1.25	\$1.86
Orange Blossom Trail	\$0.63	\$0.75	\$1.26	\$0.63	\$0.75	\$1.26	\$0.63	\$0.75	\$1.26	\$0.63	\$0.75	\$1.26
Landstar Boulevard	\$0.50	\$0.50	\$1.00	\$0.50	\$0.50	\$1.00	\$0.50	\$0.50	\$1.00	\$0.50	\$0.50	\$1.00

Notes:

- Incremental increase due to the CFX July 2012 toll rate adjustment is applied at the Beachline Mainline Toll Facility, Innovation Way ramps and to preserve toll equity along SR 528.
- Toll rates shown for the Dallas Mainline Toll Facility include a \$0.26 EPASS and \$0.75 Cash toll charge regardless of the number of axles that is allocated to the FDOT.

- Added Ponkan Toll Gantry Facility for the opening of SR 429 Wekiva Parkway Section A (July 2017).
- FDOT toll rate increase of \$0.25 for cash payment at Dallas Mainline Toll Facility October 2017.
- Added Mount Plymouth and Coronado Mainline Toll Gantry Facilities for the opening of SR 429 Wekiva Parkway Section B and SR 453 (March 2018).
- SR 538 (Poinciana Parkway) became a CFX system facility in December 2019.



Toll Rate Schedule

CFX Expressway	Motorcycle & 2 Axles			3 Axles			4 Axles			5 or More Axles		
	E-PASS	CASH	Pay-By-Plate ⁽⁴⁾	E-PASS	CASH	Pay-By-Plate ⁽⁴⁾	E-PASS	CASH	Pay-By-Plate ⁽⁴⁾	E-PASS	CASH	Pay-By-Plate ⁽⁴⁾
SR 417 (Central Florida GreeneWay) - continued												
Boggy Creek Mainline Toll Facility	\$1.56	\$1.75	\$3.12	\$2.18	\$2.50	\$4.36	\$2.82	\$3.25	\$5.64	\$3.44	\$4.00	\$6.88
South Access Road/ International Airport	\$1.25	\$1.50	\$2.50	\$1.25	\$1.50	\$2.50	\$1.25	\$1.50	\$2.50	\$1.25	\$1.50	\$2.50
Boggy Creek Road	\$1.25	\$1.50	\$2.50	\$1.25	\$1.50	\$2.50	\$1.25	\$1.50	\$2.50	\$1.25	\$1.50	\$2.50
Lake Nona Boulevard	\$0.93	\$1.25	\$1.86	\$0.93	\$1.25	\$1.86	\$0.93	\$1.25	\$1.86	\$0.93	\$1.25	\$1.86
Narcoossee Road	\$0.93	\$1.25	\$1.86	\$0.93	\$1.25	\$1.86	\$0.93	\$1.25	\$1.86	\$0.93	\$1.25	\$1.86
Moss Park Road	\$0.63	\$0.75	\$1.26	\$0.63	\$0.75	\$1.26	\$0.63	\$0.75	\$1.26	\$0.63	\$0.75	\$1.26
Innovation Way/Dowden Road	\$0.63	\$0.75	\$1.26	\$0.63	\$0.75	\$1.26	\$0.63	\$0.75	\$1.26	\$0.63	\$0.75	\$1.26
Curry Ford Mainline Toll Facility	\$0.93	\$1.25	\$1.86	\$1.89	\$2.25	\$3.78	\$2.18	\$2.50	\$4.36	\$2.82	\$3.25	\$5.64
Lee Vista Boulevard	\$0.63	\$0.75	\$1.26	\$0.63	\$0.75	\$1.26	\$0.63	\$0.75	\$1.26	\$0.63	\$0.75	\$1.26
Curry Ford Road	\$0.63	\$0.75	\$1.26	\$0.63	\$0.75	\$1.26	\$0.63	\$0.75	\$1.26	\$0.63	\$0.75	\$1.26
University Mainline Toll Facility	\$0.93	\$1.25	\$1.86	\$1.89	\$2.25	\$3.78	\$2.18	\$2.50	\$4.36	\$2.82	\$3.25	\$5.64
SR 50 (Colonial Drive)	\$0.63	\$0.75	\$1.26	\$0.63	\$0.75	\$1.26	\$0.63	\$0.75	\$1.26	\$0.63	\$0.75	\$1.26
University Boulevard	\$0.63	\$0.75	\$1.26	\$0.63	\$0.75	\$1.26	\$0.63	\$0.75	\$1.26	\$0.63	\$0.75	\$1.26
SR 429 (Western Beltway)												
Independence Mainline Toll Facility	\$1.56	\$1.75	\$3.12	\$2.18	\$2.50	\$4.36	\$2.82	\$3.25	\$5.64	\$3.44	\$4.00	\$6.88
CR 535 (Winter Garden Vineland Road)	\$0.63	\$0.75	\$1.26	\$0.63	\$0.75	\$1.26	\$0.63	\$0.75	\$1.26	\$0.63	\$0.75	\$1.26
Stoneybrook West Parkway	\$0.63	NA	\$1.26	\$0.63	NA	\$1.26	\$0.63	NA	\$1.26	\$0.63	NA	\$1.26
New Independence Parkway	\$0.93	\$1.25	\$1.86	\$0.93	\$1.25	\$1.86	\$0.93	\$1.25	\$1.86	\$0.93	\$1.25	\$1.86
Schofield Road	\$0.63	\$0.75	\$1.26	\$0.63	\$0.75	\$1.26	\$0.63	\$0.75	\$1.26	\$0.63	\$0.75	\$1.26
Forest Lake Mainline Toll Facility	\$1.56	\$1.75	\$3.12	\$2.18	\$2.50	\$4.36	\$2.82	\$3.25	\$5.64	\$3.44	\$4.00	\$6.88
CR 437A (Ocoee-Apopka Road)	\$0.63	\$0.75	\$1.26	\$0.63	\$0.75	\$1.26	\$0.63	\$0.75	\$1.26	\$0.63	\$0.75	\$1.26
West Road	\$0.93	\$1.25	\$1.86	\$0.93	\$1.25	\$1.86	\$0.93	\$1.25	\$1.86	\$0.93	\$1.25	\$1.86
Plant Street/Franklin Street/ SR 438	\$0.32	\$0.50	\$0.64	\$0.32	\$0.50	\$0.64	\$0.32	\$0.50	\$0.64	\$0.32	\$0.50	\$0.64
Ponkan Mainline Toll Gantry Facility	\$0.89	NA	\$1.78	\$1.35	NA	\$2.70	\$1.80	NA	\$3.60	\$2.24	NA	\$4.48
Mount Plymouth Mainline Toll Gantry Facility	\$0.84	NA	\$1.68	\$1.28	NA	\$2.56	\$1.67	NA	\$3.34	\$2.11	NA	\$4.22

Notes:

- Incremental increase due to the CFX July 2012 toll rate adjustment is applied at the Beachline Mainline Toll Facility, Innovation Way ramps and to preserve toll equity along SR 528.
- Toll rates shown for the Dallas Mainline Toll Facility include a \$0.26 EPASS and \$0.75 Cash toll charge regardless of the number of axles that is allocated to the FDOT.
- Added Ponkan Toll Gantry Facility for the opening of SR 429 Wekiva Parkway Section A (July 2017).
- FDOT toll rate increase of \$0.25 for cash payment at Dallas Mainline Toll Facility October 2017.
- Added Mount Plymouth and Coronado Mainline Toll Gantry Facilities for the opening of SR 429 Wekiva Parkway Section B and SR 453 (March 2018).
- SR 538 (Poinciana Parkway) became a CFX system facility in December 2019.

CFX Expressway	Motorcycle & 2 Axles			3 Axles			4 Axles			5 or More Axles		
	E-PASS	CASH	Pay-By-Plate ⁽⁴⁾	E-PASS	CASH	Pay-By-Plate ⁽⁴⁾	E-PASS	CASH	Pay-By-Plate ⁽⁴⁾	E-PASS	CASH	Pay-By-Plate ⁽⁴⁾
SR 453												
Coronado Mainline Toll Gantry Facility	\$0.71	NA	\$1.42	\$1.09	NA	\$2.18	\$1.44	NA	\$2.88	\$1.82	NA	\$3.64
SR 414 (Apopka Expressway)												
Coral Hills Mainline Toll Facility	\$0.84	\$0.00	\$1.68	\$1.28	\$0.00	\$2.56	\$1.67	\$0.00	\$3.34	\$2.11	\$0.00	\$4.22
Keene Road	\$0.62	\$0.75	\$1.24	\$0.62	\$0.75	\$1.24	\$0.62	\$0.75	\$1.24	\$0.62	\$0.75	\$1.24
Hiawassee Road	\$0.32	\$0.50	\$0.64	\$0.32	\$0.50	\$0.64	\$0.32	\$0.50	\$0.64	\$0.32	\$0.50	\$0.64
SR 538 (Poinciana Parkway)												
Marigold Mainline Toll Gantry Facility	\$2.22	NA	\$4.44	\$3.36	NA	\$6.72	\$4.43	NA	\$8.86	\$5.58	NA	\$11.16
Koa Mainline Toll Gantry Facility	\$0.55	NA	\$1.10	\$0.81	NA	\$1.62	\$1.09	NA	\$2.18	\$1.36	NA	\$2.72
Goldenrod Road Extension - Non System												
Goldenrod Mainline Toll Facility	\$0.50	\$0.50	\$1.00	\$0.50	\$0.50	\$1.00	\$0.50	\$0.50	\$1.00	\$0.50	\$0.50	\$1.00

Notes:

- Incremental increase due to the CFX July 2012 toll rate adjustment is applied at the Beachline Mainline Toll Facility, Innovation Way ramps and to preserve toll equity along SR 528.
- Toll rates shown for the Dallas Mainline Toll Facility include a \$0.26 EPASS and \$0.75 Cash toll charge regardless of the number of axles that is allocated to the FDOT.
- Added Ponkan Toll Gantry Facility for the opening of SR 429 Wekiva Parkway Section A (July 2017).
- FDOT toll rate increase of \$0.25 for cash payment at Dallas Mainline Toll Facility October 2017.
- Added Mount Plymouth and Coronado Mainline Toll Gantry Facilities for the opening of SR 429 Wekiva Parkway Section B and SR 453 (March 2018).
- SR 538 (Poinciana Parkway) became a CFX system facility in December 2019.



Toll Rate Schedule

Distance Between Interchanges



2022 Traffic Data and Statistics Manual
CENTRAL FLORIDA EXPRESSWAY AUTHORITY

Distance From	Distance To		
	Florida's Turnpike <i>Distance (miles)</i>	SR 50/Clarke Road <i>Distance (miles)</i>	Good Homes Road <i>Distance (miles)</i>
Florida's Turnpike	-----	-----	1.555
SR 50/Clarke Road	-----	-----	0.716
Good Homes Road	1.555	0.716	-----
Hiwassee Road	3.336	2.497	1.781
Kirkman Road	4.485	3.646	2.930
Pine Hills Road	-----	-----	-----
Old Winter Garden/Mercy-Ortman Drive	-----	-----	-----
John Young Parkway	7.239	6.400	5.684
Tampa Avenue	7.904	7.065	6.349
Orange Blossom Trail	8.415	7.576	6.860
Interstate 4 (I-4)	9.481	8.642	7.926
Orange Avenue	9.659	8.820	8.104
Rosalind Avenue	-----	-----	-----
Mills Avenue	-----	-----	-----
Bumby Avenue	11.199	10.360	9.644
Crystal Lake Drive	-----	-----	-----
Conway Road	12.445	11.606	10.890
Andes Avenue	13.188	12.349	11.633
Semoran Boulevard (SR 436)	13.719	12.880	12.164
Yucatan Drive	-----	-----	-----
Goldenrod Road	15.235	14.396	13.680
Chickasaw Trail	15.807	14.968	14.252
SR 417 (GreeneWay)	17.035	16.196	15.480
Dean Road	17.859	17.020	16.304
Rouse Road	19.134	18.295	17.579
Alafaya Trail	20.335	19.496	18.780
SR 50 (East Colonial Drive)	21.954	21.115	20.399

Distance From	Distance To		
	Hiawassee Road <i>Distance (miles)</i>	Kirkman Road <i>Distance (miles)</i>	Pine Hills Road <i>Distance (miles)</i>
Florida's Turnpike	3.336	4.485	-----
SR 50/Clarke Road	2.497	3.646	-----
Good Homes Road	1.781	2.930	-----
Hiawassee Road	-----	1.149	-----
Kirkman Road	1.149	-----	-----
Pine Hills Road	-----	-----	-----
Old Winter Garden/Mercy-Ortman Drive	-----	-----	-----
John Young Parkway	3.903	2.754	2.162
Tampa Avenue	4.568	3.419	2.827
Orange Blossom Trail	5.079	3.930	3.338
Interstate 4 (I-4)	6.145	4.996	4.404
Orange Avenue	6.324	5.175	4.583
Rosalind Avenue	-----	-----	-----
Mills Avenue	-----	-----	-----
Bumby Avenue	7.864	6.715	6.123
Crystal Lake Drive	-----	-----	-----
Conway Road	9.110	7.961	7.369
Andes Avenue	9.853	8.704	8.112
Semoran Boulevard (SR 436)	10.384	9.235	8.643
Yucatan Drive	-----	-----	-----
Goldenrod Road	11.899	10.750	10.158
Chickasaw Trail	12.471	11.322	10.730
SR 417 (GreeneWay)	13.699	12.550	11.958
Dean Road	14.524	13.375	12.783
Rouse Road	15.798	14.649	14.057
Alafaya Trail	16.999	15.850	15.258
SR 50 (East Colonial Drive)	18.619	17.470	16.878

Distance From	Distance To		
	OWG/Mercy/Ortman Distance (miles)	John Young Parkway Distance (miles)	Tampa Avenue Distance (miles)
Florida's Turnpike	-----	7.239	7.904
SR 50/Clarke Road	-----	6.400	7.065
Good Homes Road	-----	5.684	6.349
Hiwassee Road	-----	3.903	4.568
Kirkman Road	-----	2.754	3.419
Pine Hills Road	-----	2.162	2.827
Old Winter Garden/Mercy-Ortman Drive	-----	1.077	1.742
John Young Parkway	1.077	-----	0.665
Tampa Avenue	1.742	0.665	-----
Orange Blossom Trail	2.253	1.176	-----
Interstate 4 (I-4)	3.319	2.242	-----
Orange Avenue	3.498	2.421	-----
Rosalind Avenue	-----	-----	-----
Mills Avenue	-----	-----	-----
Bumby Avenue	5.038	3.961	-----
Crystal Lake Drive	-----	-----	-----
Conway Road	6.284	5.207	-----
Andes Avenue	7.027	5.950	-----
Semoran Boulevard (SR 436)	7.558	6.481	-----
Yucatan Drive	-----	-----	-----
Goldenrod Road	9.073	7.996	-----
Chickasaw Trail	9.645	8.568	-----
SR 417 (GreeneWay)	10.873	9.796	-----
Dean Road	11.698	10.621	-----
Rouse Road	12.972	11.895	-----
Alafaya Trail	14.173	13.096	-----
SR 50 (East Colonial Drive)	15.793	14.716	-----

Distance From	Distance To		
	Orange Blossom Trail <i>Distance (miles)</i>	Interstate 4 (I-4) <i>Distance (miles)</i>	Orange Avenue <i>Distance (miles)</i>
Florida's Turnpike	8.415	9.481	9.659
SR 50/Clarke Road	7.576	8.642	8.820
Good Homes Road	6.860	7.926	8.104
Hiwassee Road	5.079	6.145	6.324
Kirkman Road	3.930	4.996	5.175
Pine Hills Road	3.338	4.404	4.583
Old Winter Garden/Mercy-Ortman Drive	2.253	3.319	3.498
John Young Parkway	1.176	2.242	2.421
Tampa Avenue	-----	-----	-----
Orange Blossom Trail	-----	1.066	1.245
Interstate 4 (I-4)	1.066	-----	-----
Orange Avenue	1.245	-----	-----
Rosalind Avenue	-----	-----	-----
Mills Avenue	-----	-----	-----
Bumby Avenue	2.785	1.718	-----
Crystal Lake Drive	-----	-----	-----
Conway Road	4.031	2.964	-----
Andes Avenue	4.774	3.707	-----
Semoran Boulevard (SR 436)	5.305	4.238	-----
Yucatan Drive	-----	-----	-----
Goldenrod Road	6.820	5.754	-----
Chickasaw Trail	7.392	6.326	-----
SR 417 (GreeneWay)	8.620	7.554	-----
Dean Road	9.445	8.378	-----
Rouse Road	10.719	9.653	-----
Alafaya Trail	11.920	10.854	-----
SR 50 (East Colonial Drive)	13.540	12.473	-----

Distance From	Distance To		
	Rosalind Avenue <i>Distance (miles)</i>	Mills Avenue <i>Distance (miles)</i>	Bumby Avenue <i>Distance (miles)</i>
Florida's Turnpike	-----	10.438	11.199
SR 50/Clarke Road	-----	9.599	10.360
Good Homes Road	-----	8.883	9.644
Hiwassee Road	-----	7.102	7.864
Kirkman Road	-----	5.953	6.715
Pine Hills Road	-----	5.361	6.123
Old Winter Garden/Mercy-Ortman Drive	-----	4.276	5.038
John Young Parkway	-----	3.199	3.961
Tampa Avenue	-----	-----	-----
Orange Blossom Trail	-----	2.023	2.785
Interstate 4 (I-4)	-----	0.957	1.718
Orange Avenue	-----	-----	-----
Rosalind Avenue	-----	0.494	1.256
Mills Avenue	-----	-----	0.762
Bumby Avenue	1.256	0.762	-----
Crystal Lake Drive	-----	-----	-----
Conway Road	2.502	2.008	-----
Andes Avenue	3.245	2.751	-----
Semoran Boulevard (SR 436)	3.776	3.282	-----
Yucatan Drive	-----	-----	-----
Goldenrod Road	5.292	4.797	-----
Chickasaw Trail	5.864	5.369	-----
SR 417 (GreeneWay)	7.092	6.597	-----
Dean Road	7.916	7.422	-----
Rouse Road	9.191	8.696	-----
Alafaya Trail	10.392	9.897	-----
SR 50 (East Colonial Drive)	12.011	11.517	-----

Distance From	Distance To		
	Crystal Lake Drive <i>Distance (miles)</i>	Conway Road <i>Distance (miles)</i>	Andes Avenue <i>Distance (miles)</i>
Florida's Turnpike	-----	12.445	13.188
SR 50/Clarke Road	-----	11.606	12.349
Good Homes Road	-----	10.890	11.633
Hiawassee Road	-----	9.110	9.853
Kirkman Road	-----	7.961	8.704
Pine Hills Road	-----	7.369	8.112
Old Winter Garden/Mercy-Ortman Drive	-----	6.284	7.027
John Young Parkway	-----	5.207	5.950
Tampa Avenue	-----	-----	-----
Orange Blossom Trail	-----	4.031	4.774
Interstate 4 (I-4)	-----	2.964	3.707
Orange Avenue	-----	-----	-----
Rosalind Avenue	-----	2.502	3.245
Mills Avenue	-----	2.008	2.751
Bumby Avenue	-----	-----	-----
Crystal Lake Drive	-----	0.743	1.487
Conway Road	0.743	-----	-----
Andes Avenue	1.487	-----	-----
Semoran Boulevard (SR 436)	2.018	-----	-----
Yucatan Drive	-----	-----	-----
Goldenrod Road	3.533	-----	-----
Chickasaw Trail	4.105	-----	-----
SR 417 (GreeneWay)	5.333	-----	-----
Dean Road	6.158	-----	-----
Rouse Road	7.432	-----	-----
Alafaya Trail	8.633	-----	-----
SR 50 (East Colonial Drive)	10.253	-----	-----

Distance From	Distance To		
	Semoran Boulevard <i>Distance (miles)</i>	Yucatan Drive <i>Distance (miles)</i>	Goldenrod Road <i>Distance (miles)</i>
Florida's Turnpike	-----	-----	15.235
SR 50/Clarke Road	-----	-----	14.396
Good Homes Road	-----	-----	13.680
Hiwassee Road	-----	-----	11.899
Kirkman Road	-----	-----	10.750
Pine Hills Road	-----	-----	10.158
Old Winter Garden/Mercy-Ortman Drive	-----	-----	9.073
John Young Parkway	-----	-----	7.996
Tampa Avenue	-----	-----	-----
Orange Blossom Trail	-----	-----	6.820
Interstate 4 (I-4)	-----	-----	5.754
Orange Avenue	-----	-----	-----
Rosalind Avenue	-----	-----	5.292
Mills Avenue	-----	-----	4.797
Bumby Avenue	-----	-----	-----
Crystal Lake Drive	-----	-----	3.533
Conway Road	-----	-----	-----
Andes Avenue	-----	-----	-----
Semoran Boulevard (SR 436)	-----	-----	-----
Yucatan Drive	-----	-----	1.234
Goldenrod Road	1.516	-----	-----
Chickasaw Trail	2.088	-----	-----
SR 417 (GreeneWay)	3.316	-----	1.800
Dean Road	4.140	-----	2.625
Rouse Road	5.415	-----	3.899
Alafaya Trail	6.616	-----	5.100
SR 50 (East Colonial Drive)	8.235	-----	6.720

Distance From	Distance To		
	Chickasaw Trail Distance (miles)	SR 417 (GreeneWay) Distance (miles)	Dean Road Distance (miles)
Florida's Turnpike	15.807	17.035	17.859
SR 50/Clarke Road	14.968	16.196	17.020
Good Homes Road	14.252	15.480	16.304
Hiwassee Road	12.471	13.699	14.524
Kirkman Road	11.322	12.550	13.375
Pine Hills Road	10.730	11.958	12.783
Old Winter Garden/Mercy-Ortman Drive	9.645	10.873	11.698
John Young Parkway	8.568	9.796	10.621
Tampa Avenue	-----	-----	-----
Orange Blossom Trail	7.392	8.620	9.445
Interstate 4 (I-4)	6.326	7.554	8.378
Orange Avenue	-----	-----	-----
Rosalind Avenue	5.864	7.092	7.916
Mills Avenue	5.369	6.597	7.422
Bumby Avenue	-----	-----	-----
Crystal Lake Drive	4.105	5.333	6.158
Conway Road	-----	-----	-----
Andes Avenue	-----	-----	-----
Semoran Boulevard (SR 436)	-----	-----	-----
Yucatan Drive	1.806	3.034	3.859
Goldenrod Road	-----	1.800	2.625
Chickasaw Trail	-----	-----	-----
SR 417 (GreeneWay)	-----	-----	0.824
Dean Road	-----	0.824	-----
Rouse Road	-----	2.099	1.275
Alafaya Trail	-----	3.300	2.476
SR 50 (East Colonial Drive)	-----	4.919	4.095

Distance From	Distance To		
	Rouse Road Distance (miles)	Alafaya Trail Distance (miles)	SR 50 (Colonial Dr.) Distance (miles)
Florida's Turnpike	19.134	20.335	21.954
SR 50/Clarke Road	18.295	19.496	21.115
Good Homes Road	17.579	18.780	20.399
Hiawassee Road	15.798	16.999	18.619
Kirkman Road	14.649	15.850	17.470
Pine Hills Road	14.057	15.258	16.878
Old Winter Garden/Mercy-Ortman Drive	12.972	14.173	15.793
John Young Parkway	11.895	13.096	14.716
Tampa Avenue	-----	-----	-----
Orange Blossom Trail	10.719	11.920	13.540
Interstate 4 (I-4)	9.653	10.854	12.473
Orange Avenue	-----	-----	-----
Rosalind Avenue	9.191	10.392	12.011
Mills Avenue	8.696	9.897	11.517
Bumby Avenue	-----	-----	-----
Crystal Lake Drive	7.432	8.633	10.253
Conway Road	-----	-----	-----
Andes Avenue	-----	-----	-----
Semoran Boulevard (SR 436)	-----	-----	-----
Yucatan Drive	5.133	6.334	7.954
Goldenrod Road	3.899	5.100	6.720
Chickasaw Trail	-----	-----	-----
SR 417 (GreeneWay)	2.099	3.300	4.919
Dean Road	1.275	2.476	4.095
Rouse Road	-----	1.201	2.821
Alafaya Trail	1.201	-----	-----
SR 50 (East Colonial Drive)	2.821	-----	-----

Distance From	Distance To		
	Boggy Creek Road <i>Distance (miles)</i>	Tradeport/Conway <i>Distance (miles)</i>	Semoran Blvd/Airport <i>Distance (miles)</i>
US 441/Florida's Turnpike	3.580	4.657	6.157
Boggy Creek Road	-----	1.077	2.577
Tradeport Drive/Conway Road	1.077	-----	1.501
Semoran Boulevard/Airport	2.577	1.501	-----
Goldenrod Road	3.940	2.863	1.363
Narcoossee Road	5.295	4.218	2.718
SR 417 (GreeneWay)	7.385	6.308	4.807
Innovation Way ⁽¹⁾	11.024	9.947	8.447
Dallas Boulevard	15.617	14.540	13.040
SR 520	22.667	21.591	20.090
Brevard County Line	27.605	26.529	25.028

Distance From	Distance To		
	Goldenrod Road <i>Distance (miles)</i>	Narcoossee Road <i>Distance (miles)</i>	SR 417 (GreeneWay) <i>Distance (miles)</i>
US 441/Florida's Turnpike	7.520	8.875	10.965
Boggy Creek Road	3.940	5.295	7.385
Tradeport Drive/Conway Road	2.863	4.218	6.308
Semoran Boulevard/Airport	1.363	2.718	4.807
Goldenrod Road	-----	1.355	3.445
Narcoossee Road	1.355	-----	2.090
SR 417 (GreeneWay)	3.445	2.090	-----
Innovation Way ⁽¹⁾	7.084	5.729	3.639
Dallas Boulevard	11.677	10.322	8.232
SR 520	18.728	17.373	15.283
Brevard County Line	23.666	22.311	20.221

Distance From	Distance To	
	Innovation Way ⁽¹⁾ <i>Distance (miles)</i>	Dallas Boulevard <i>Distance (miles)</i>
US 441/Florida's Turnpike	14.604	19.197
Boggy Creek Road	11.024	15.617
Tradeport Drive/Conway Road	9.947	14.540
Semoran Boulevard/Airport	8.447	13.040
Goldenrod Road	7.084	11.677
Narcoossee Road	5.729	10.322
SR 417 (GreeneWay)	3.639	8.232
Innovation Way ⁽¹⁾	-----	4.593
Dallas Boulevard	4.593	-----
SR 520	11.644	-----
Brevard County Line	16.582	-----

Distance From	Distance To	
	SR 520 <i>Distance (miles)</i>	Brevard County Line <i>Distance (miles)</i>
US 441/Florida's Turnpike	26.247	31.185
Boggy Creek Road	22.667	27.605
Tradeport Drive/Conway Road	21.591	26.529
Semoran Boulevard/Airport	20.090	25.028
Goldenrod Road	18.728	23.666
Narcoossee Road	17.373	22.311
SR 417 (GreeneWay)	15.283	20.221
Innovation Way ⁽¹⁾	11.644	16.582
Dallas Boulevard	-----	-----
SR 520	-----	4.938
Brevard County Line	4.938	-----

Distance From	Distance To		
	International Drive <i>Distance (miles)</i>	John Young Parkway <i>Distance (miles)</i>	Orange Blossom Trail <i>Distance (miles)</i>
International Drive	-----	4.240	5.606
John Young Parkway	4.240	-----	1.366
Orange Blossom Trail	5.606	1.366	-----
Florida's Turnpike	-----	-----	-----
Landstar Boulevard	7.952	3.712	2.346
South Access Road (International Airport)	11.475	7.234	5.869
Boggy Creek Road	11.475	7.234	5.869
Lake Nona Boulevard	13.566	9.326	7.960
Narcoossee Road	16.119	11.879	10.513
Moss Park Road	17.579	13.339	11.973
Dowden Road	18.503	14.262	12.897
SR 528 (Beachline Expressway)	20.132	15.892	14.526
Lee Vista Boulevard	22.033	17.793	16.427
Curry Ford Road	24.336	20.096	18.730
SR 408 (East-West Expressway)	27.064	22.823	21.458
SR 50 (Colonial Drive)	28.756	24.515	23.150
University Boulevard	31.024	26.783	25.418
Aloma Avenue	32.657	28.417	27.051

Distance From	Distance To		
	Florida's Turnpike <i>Distance (miles)</i>	Landstar Boulevard <i>Distance (miles)</i>	South Access (Airport) <i>Distance (miles)</i>
International Drive	6.575	7.952	11.475
John Young Parkway	2.334	3.712	7.234
Orange Blossom Trail	0.969	2.346	5.869
Florida's Turnpike	-----	1.378	4.900
Landstar Boulevard	1.378	-----	3.523
South Access Road (International Airport)	4.900	3.523	-----
Boggy Creek Road	4.900	3.523	-----
Lake Nona Boulevard	6.992	5.614	2.092
Narcoossee Road	9.545	8.167	4.645
Moss Park Road	11.004	9.627	6.104
Dowden Road	11.928	10.551	7.028
SR 528 (Beachline Expressway)	13.558	12.180	8.658
Lee Vista Boulevard	15.459	14.081	10.559
Curry Ford Road	17.762	16.384	12.862
SR 408 (East-West Expressway)	20.489	19.112	15.589
SR 50 (Colonial Drive)	22.181	20.804	17.281
University Boulevard	24.449	23.072	19.549
Aloma Avenue	26.083	24.705	21.183

Distance From	Distance To		
	Boggy Creek Road <i>Distance (miles)</i>	Lake Nona Boulevard <i>Distance (miles)</i>	Narcoossee Road <i>Distance (miles)</i>
International Drive	11.475	13.566	16.119
John Young Parkway	7.234	9.326	11.879
Orange Blossom Trail	5.869	7.960	10.513
Florida's Turnpike	4.900	6.992	9.545
Landstar Boulevard	3.523	5.614	8.167
South Access Road (International Airport)	-----	2.092	4.645
Boggy Creek Road	-----	2.092	4.645
Lake Nona Boulevard	2.092	-----	2.553
Narcoossee Road	4.645	2.553	-----
Moss Park Road	6.104	4.013	1.460
Dowden Road	7.028	4.937	2.384
SR 528 (Beachline Expressway)	8.658	6.566	4.013
Lee Vista Boulevard	10.559	8.467	5.914
Curry Ford Road	12.862	10.770	8.217
SR 408 (East-West Expressway)	15.589	13.498	10.945
SR 50 (Colonial Drive)	17.281	15.190	12.637
University Boulevard	19.549	17.458	14.905
Aloma Avenue	21.183	19.091	16.538

Distance From	Distance To		
	Moss Park Road <i>Distance (miles)</i>	Dowden Road <i>Distance (miles)</i>	SR 528 (Beachline) <i>Distance (miles)</i>
International Drive	17.579	18.503	20.132
John Young Parkway	13.339	14.262	15.892
Orange Blossom Trail	11.973	12.897	14.526
Florida's Turnpike	11.004	11.928	13.558
Landstar Boulevard	9.627	10.551	12.180
South Access Road (International Airport)	6.104	7.028	8.658
Boggy Creek Road	6.104	7.028	8.658
Lake Nona Boulevard	4.013	4.937	6.566
Narcoossee Road	1.460	2.384	4.013
Moss Park Road	-----	0.924	2.553
Dowden Road	0.924	-----	1.630
SR 528 (Beachline Expressway)	2.553	1.630	-----
Lee Vista Boulevard	4.454	3.531	1.901
Curry Ford Road	6.757	5.834	4.204
SR 408 (East-West Expressway)	9.485	8.561	6.932
SR 50 (Colonial Drive)	11.177	10.253	8.624
University Boulevard	13.445	12.521	10.892
Aloma Avenue	15.078	14.155	12.525

Distance From	Distance To		
	Lee Vista Boulevard <i>Distance (miles)</i>	Curry Ford Road <i>Distance (miles)</i>	SR 408 (East West) <i>Distance (miles)</i>
International Drive	22.033	24.336	27.064
John Young Parkway	17.793	20.096	22.823
Orange Blossom Trail	16.427	18.730	21.458
Florida's Turnpike	15.459	17.762	20.489
Landstar Boulevard	14.081	16.384	19.112
South Access Road (International Airport)	10.559	12.862	15.589
Boggy Creek Road	10.559	12.862	15.589
Lake Nona Boulevard	8.467	10.770	13.498
Narcoossee Road	5.914	8.217	10.945
Moss Park Road	4.454	6.757	9.485
Dowden Road	3.531	5.834	8.561
SR 528 (Beachline Expressway)	1.901	4.204	6.932
Lee Vista Boulevard	-----	2.303	5.031
Curry Ford Road	2.303	-----	2.728
SR 408 (East-West Expressway)	5.031	2.728	-----
SR 50 (Colonial Drive)	6.723	4.420	1.692
University Boulevard	8.991	6.688	3.960
Aloma Avenue	10.624	8.321	5.594

Distance From	Distance To		
	SR 50 (Colonial Dr.) <i>Distance (miles)</i>	University Boulevard <i>Distance (miles)</i>	Aloma Avenue <i>Distance (miles)</i>
International Drive	28.756	31.024	32.657
John Young Parkway	24.515	26.783	28.417
Orange Blossom Trail	23.150	25.418	27.051
Florida's Turnpike	22.181	24.449	26.083
Landstar Boulevard	20.804	23.072	24.705
South Access Road (International Airport)	17.281	19.549	21.183
Boggy Creek Road	17.281	19.549	21.183
Lake Nona Boulevard	15.190	17.458	19.091
Narcoossee Road	12.637	14.905	16.538
Moss Park Road	11.177	13.445	15.078
Dowden Road	10.253	12.521	14.155
SR 528 (Beachline Expressway)	8.624	10.892	12.525
Lee Vista Boulevard	6.723	8.991	10.624
Curry Ford Road	4.420	6.688	8.321
SR 408 (East-West Expressway)	1.692	3.960	5.594
SR 50 (Colonial Drive)	-----	2.268	3.902
University Boulevard	2.268	-----	1.634
Aloma Avenue	3.902	1.634	-----

Distance From	Distance To		
	Seidel Road <i>Distance (miles)</i>	Schofield Road <i>Distance (miles)</i>	New Independence <i>Distance (miles)</i>
Seidel Road	-----	2.120	4.079
Schofield Road	2.120	-----	1.959
New Independence Parkway	4.079	1.959	-----
Stoneybrook West Parkway	-----	-----	-----
CR 535 (Winter Garden Vineland Road)	8.449	6.329	4.370
Florida's Turnpike (SR 91)	11.416	9.296	7.337
SR 50 (West Colonial Drive)	11.749	9.629	7.670
Plant Street/Franklin Street/SR 438	13.189	11.069	9.110
West Road	15.700	13.581	11.622
CR 437A (Ocoee Apopka Road)	18.205	16.086	14.127
SR 414 (Apopka Expressway)	19.556	17.436	15.477
SR 429 Connector Road	22.985	20.866	18.907
Kelly Park Road	27.043	24.923	22.964
SR 453	28.128	26.009	24.050
SR 46	33.010	30.890	28.931

Distance From	Distance To		
	Stoneybrook Parkway <i>Distance (miles)</i>	CR 535 <i>Distance (miles)</i>	Florida's Turnpike <i>Distance (miles)</i>
Seidel Road	-----	8.449	11.416
Schofield Road	-----	6.329	9.296
New Independence Parkway	-----	4.370	7.337
Stoneybrook West Parkway	-----	1.270	4.237
CR 535 (Winter Garden Vineland Road)	1.270	-----	2.967
Florida's Turnpike (SR 91)	4.237	2.967	-----
SR 50 (West Colonial Drive)	4.570	3.300	-----
Plant Street/Franklin Street/SR 438	6.010	4.740	1.773
West Road	8.521	7.252	4.284
CR 437A (Ocoee Apopka Road)	11.026	9.757	6.790
SR 414 (Apopka Expressway)	12.377	11.107	8.140
SR 429 Connector Road	15.806	14.537	11.569
Kelly Park Road	19.864	18.594	15.627
SR 453	20.949	19.680	16.712
SR 46	25.831	24.561	21.594

Distance From	Distance To		
	SR 50 (Colonial Dr.) Distance (miles)	Plant/Franklin St. Distance (miles)	West Road Distance (miles)
Seidel Road	11.749	13.189	15.700
Schofield Road	9.629	11.069	13.581
New Independence Parkway	7.670	9.110	11.622
Stoneybrook West Parkway	4.570	6.010	8.521
CR 535 (Winter Garden Vineland Road)	3.300	4.740	7.252
Florida's Turnpike (SR 91)	-----	1.773	4.284
SR 50 (West Colonial Drive)	-----	1.440	3.951
Plant Street/Franklin Street/SR 438	1.440	-----	2.512
West Road	3.951	2.512	-----
CR 437A (Ocoee Apopka Road)	6.457	5.017	2.505
SR 414 (Apopka Expressway)	7.807	6.367	3.856
SR 429 Connector Road	11.236	9.797	7.285
Kelly Park Road	15.294	13.854	11.343
SR 453	16.379	14.940	12.428
SR 46	21.261	19.821	17.310

Distance From	Distance To		
	CR 437A Distance (miles)	SR 414 (Apopka Expressway) Distance (miles)	SR 429 Connector Road Distance (miles)
Seidel Road	18.205	19.556	22.985
Schofield Road	16.086	17.436	20.866
Stoneybrook West Parkway	14.127	15.477	18.907
New Independence Parkway	11.026	12.377	15.806
CR 535 (Winter Garden Vineland Road)	9.757	11.107	14.537
Florida's Turnpike (SR 91)	6.790	8.140	11.569
SR 50 (West Colonial Drive)	6.457	7.807	11.236
Plant Street/Franklin Street/SR 438	5.017	6.367	9.797
West Road	2.505	3.856	7.285
CR 437A (Ocoee Apopka Road)	-----	1.351	4.780
SR 414 (Apopka Expressway)	1.351	-----	3.429
SR 429 Connector Road	4.780	3.429	-----
Kelly Park Road	8.837	7.487	4.058
SR 453	9.923	8.572	5.143
SR 46	14.805	13.454	10.025



Distance Between Interchanges (Miles)
SR 429 (WESTERN BELTWAY)

Distance From	Distance To		
	Kelly Park Road <i>Distance (miles)</i>	SR 453 <i>Distance (miles)</i>	SR 46 <i>Distance (miles)</i>
Seidel Road	27.043	28.128	33.010
Schofield Road	24.923	26.009	30.890
New Independence Parkway	22.964	24.050	28.931
Stoneybrook West Parkway	19.864	20.949	25.831
CR 535 (Winter Garden Vineland Road)	18.594	19.680	24.561
Florida's Turnpike (SR 91)	15.627	16.712	21.594
SR 50 (West Colonial Drive)	15.294	16.379	21.261
Plant Street/Franklin Street/SR 438	13.854	14.940	19.821
West Road	11.343	12.428	17.310
CR 437A (Ocoee Apopka Road)	8.837	9.923	14.805
SR 414 (Apopka Expressway)	7.487	8.572	13.454
SR 429 Connector Road	4.058	5.143	10.025
Kelly Park Road	-----	1.086	5.967
SR 453	1.086	-----	4.882
SR 46	5.967	4.882	-----

Distance From	Distance To		
	SR 429 Connector Road Distance (miles)	SR 451 Distance (miles)	Marden Road Distance (miles)
SR 429 Connector Road	-----	4.226	4.520
SR 451 (Western Beltway)	4.226	-----	0.294
Marden Road	4.520	0.294	-----
Keene Road	6.641	2.415	2.121
Hiawassee Road (CR 435)	7.931	3.705	3.411
OBT - US 441 (East)	9.383	5.157	4.864
Bear Lake Road/Rose Avenue	10.075	5.849	5.556

Distance From	Distance To			
	Keene Road Distance (miles)	Hiawassee Road Distance (miles)	OBT - US 441 (East) Distance (miles)	Bear Lake/Rose Avenue Distance (miles)
SR 429 Connector Road	6.641	7.931	9.383	10.075
SR 451 (Western Beltway)	2.415	3.705	5.157	5.849
Marden Road	2.121	3.411	4.864	5.556
Keene Road	-----	1.290	2.743	3.435
Hiawassee Road (CR 435)	1.290	-----	1.453	2.145
OBT - US 441 (East)	2.743	1.453	-----	0.692
Bear Lake Road/Rose Avenue	3.435	2.145	0.692	-----

Distance From	Distance To	
	US 441/Vick Road Ext. <i>Distance (miles)</i>	SR 429 Interchange <i>Distance (miles)</i>
US 441/Vick Road Extension	-----	1.868
SR 429 Interchange	1.868	-----

Distance From	Distance To	
	SR 429 Interchange <i>Distance (miles)</i>	SR 46 <i>Distance (miles)</i>
SR 429 Interchange	-----	1.983
SR 46	1.983	-----

Distance From	Distance To			
	Osceola/Polk Co. Line <i>Distance (miles)</i>	Marigold Avenue <i>Distance (miles)</i>	Koa Street <i>Distance (miles)</i>	Cypress Parkway <i>Distance (miles)</i>
Osceola/Polk County Line	-----	3.968	6.365	7.194
Marigold Avenue	3.968	-----	2.397	3.226
Koa Street	6.365	2.397	-----	0.829
Cypress Parkway	7.194	3.226	0.829	-----

Toll Rates Between Interchanges



2022 Traffic Data and Statistics Manual
CENTRAL FLORIDA EXPRESSWAY AUTHORITY

From	To								
	Florida's Turnpike			SR 50/Clarke Road			Good Homes Road		
	E-PASS	CASH	Pay-By-Plate	E-PASS	CASH	Pay-By-Plate	E-PASS	CASH	Pay-By-Plate
Florida's Turnpike	-----	-----	-----	-----	-----	-----	\$0.28	\$0.50	\$0.56
SR 50/Clarke Road	-----	-----	-----	-----	-----	-----	\$0.28	\$0.50	\$0.56
Good Homes Road	\$0.28	\$0.50	\$0.56	\$0.28	\$0.50	\$0.56	-----	-----	-----
Hiawassee Road	\$0.93	\$1.25	\$1.86	\$0.93	\$1.25	\$1.86	\$0.93	\$1.25	\$1.86
Kirkman Road	\$0.93	\$1.25	\$1.86	\$0.93	\$1.25	\$1.86	\$0.93	\$1.25	\$1.86
Pine Hills Road	-----	-----	-----	-----	-----	-----	-----	-----	-----
Old Winter Garden/Mercy-Ortman Drive	-----	-----	-----	-----	-----	-----	-----	-----	-----
John Young Parkway	\$2.18	\$2.75	\$4.36	\$2.18	\$2.75	\$4.36	\$2.18	\$2.75	\$4.36
Tampa Avenue	\$2.18	\$2.75	\$4.36	\$2.18	\$2.75	\$4.36	\$2.18	\$2.75	\$4.36
Orange Blossom Trail	\$2.18	\$2.75	\$4.36	\$2.18	\$2.75	\$4.36	\$2.18	\$2.75	\$4.36
Interstate 4 (I-4)	\$2.18	\$2.75	\$4.36	\$2.18	\$2.75	\$4.36	\$2.18	\$2.75	\$4.36
Orange Avenue	\$2.18	\$2.75	\$4.36	\$2.18	\$2.75	\$4.36	\$2.18	\$2.75	\$4.36
Rosalind Avenue	-----	-----	-----	-----	-----	-----	-----	-----	-----
Mills Avenue	-----	-----	-----	-----	-----	-----	-----	-----	-----
Bumby Avenue	\$2.81	\$3.50	\$5.62	\$2.81	\$3.50	\$5.62	\$2.81	\$3.50	\$5.62
Crystal Lake Drive	-----	-----	-----	-----	-----	-----	-----	-----	-----
Conway Road	\$3.11	\$4.00	\$6.22	\$3.11	\$4.00	\$6.22	\$3.11	\$4.00	\$6.22
Andes Avenue	\$3.43	\$4.25	\$6.86	\$3.43	\$4.25	\$6.86	\$3.43	\$4.25	\$6.86
Semoran Boulevard (SR 436)	\$3.43	\$4.25	\$6.86	\$3.43	\$4.25	\$6.86	\$3.43	\$4.25	\$6.86
Yucatan Drive	-----	-----	-----	-----	-----	-----	-----	-----	-----
Goldenrod Road	\$3.43	\$4.25	\$6.86	\$3.43	\$4.25	\$6.86	\$3.43	\$4.25	\$6.86
Chickasaw Trail	\$3.43	\$4.25	\$6.86	\$3.43	\$4.25	\$6.86	\$3.43	\$4.25	\$6.86
SR 417 (GreeneWay)	\$3.43	\$4.25	\$6.86	\$3.43	\$4.25	\$6.86	\$3.43	\$4.25	\$6.86
Dean Road	\$4.06	\$5.00	\$8.12	\$4.06	\$5.00	\$8.12	\$4.06	\$5.00	\$8.12
Rouse Road	\$4.36	\$5.50	\$8.72	\$4.36	\$5.50	\$8.72	\$4.36	\$5.50	\$8.72
Alafaya Trail	\$4.36	\$5.50	\$8.72	\$4.36	\$5.50	\$8.72	\$4.36	\$5.50	\$8.72
SR 50 (East Colonial Drive)	\$4.36	\$5.50	\$8.72	\$4.36	\$5.50	\$8.72	\$4.36	\$5.50	\$8.72



**Toll Rates Between Interchanges -
2 Axle Vehicles Only
SR 408 (EAST-WEST EXPRESSWAY)**

(Effective July 1, 2023)

From	To								
	Hiawassee Road			Kirkman Road			Pine Hills Road		
	E-PASS	CASH	Pay-By-Plate	E-PASS	CASH	Pay-By-Plate	E-PASS	CASH	Pay-By-Plate
Florida's Turnpike	\$0.93	\$1.25	\$1.86	\$0.93	\$1.25	\$1.86	-----	-----	-----
SR 50/Clarke Road	\$0.93	\$1.25	\$1.86	\$0.93	\$1.25	\$1.86	-----	-----	-----
Good Homes Road	\$0.93	\$1.25	\$1.86	\$0.93	\$1.25	\$1.86	-----	-----	-----
Hiawassee Road	-----	-----	-----	\$0.63	\$0.75	\$1.26	-----	-----	-----
Kirkman Road	\$0.63	\$0.75	\$1.26	-----	-----	-----	-----	-----	-----
Pine Hills Road	-----	-----	-----	-----	-----	-----	-----	-----	-----
Old Winter Garden/Mercy-Ortman Drive	-----	-----	-----	-----	-----	-----	-----	-----	-----
John Young Parkway	\$1.88	\$2.25	\$3.76	\$1.25	\$1.50	\$2.50	\$1.25	\$1.50	\$2.50
Tampa Avenue	\$1.88	\$2.25	\$3.76	\$1.25	\$1.50	\$2.50	\$1.25	\$1.50	\$2.50
Orange Blossom Trail	\$1.88	\$2.25	\$3.76	\$1.25	\$1.50	\$2.50	\$1.25	\$1.50	\$2.50
Interstate 4 (I-4)	\$1.88	\$2.25	\$3.76	\$1.25	\$1.50	\$2.50	\$1.25	\$1.50	\$2.50
Orange Avenue	\$1.88	\$2.25	\$3.76	\$1.25	\$1.50	\$2.50	\$1.25	\$1.50	\$2.50
Rosalind Avenue	-----	-----	-----	-----	-----	-----	-----	-----	-----
Mills Avenue	-----	-----	-----	-----	-----	-----	-----	-----	-----
Bumby Avenue	\$2.51	\$3.00	\$5.02	\$1.88	\$2.25	\$3.76	\$1.88	\$2.25	\$3.76
Crystal Lake Drive	-----	-----	-----	-----	-----	-----	-----	-----	-----
Conway Road	\$2.81	\$3.50	\$5.62	\$2.18	\$2.75	\$4.36	\$2.18	\$2.75	\$4.36
Andes Avenue	\$3.13	\$3.75	\$6.26	\$2.50	\$3.00	\$5.00	\$2.50	\$3.00	\$5.00
Semorán Boulevard (SR 436)	\$3.13	\$3.75	\$6.26	\$2.50	\$3.00	\$5.00	\$2.50	\$3.00	\$5.00
Yucatan Drive	-----	-----	-----	-----	-----	-----	-----	-----	-----
Goldenrod Road	\$3.13	\$3.75	\$6.26	\$2.50	\$3.00	\$5.00	\$2.50	\$3.00	\$5.00
Chickasaw Trail	\$3.13	\$3.75	\$6.26	\$2.50	\$3.00	\$5.00	\$2.50	\$3.00	\$5.00
SR 417 (GreeneWay)	\$3.13	\$3.75	\$6.26	\$2.50	\$3.00	\$5.00	\$2.50	\$3.00	\$5.00
Dean Road	\$3.76	\$4.50	\$7.52	\$3.13	\$3.75	\$6.26	\$3.13	\$3.75	\$6.26
Rouse Road	\$4.06	\$5.00	\$8.12	\$3.43	\$4.25	\$6.86	\$3.43	\$4.25	\$6.86
Alafaya Trail	\$4.06	\$5.00	\$8.12	\$3.43	\$4.25	\$6.86	\$3.43	\$4.25	\$6.86
SR 50 (East Colonial Drive)	\$4.06	\$5.00	\$8.12	\$3.43	\$4.25	\$6.86	\$3.43	\$4.25	\$6.86



**Toll Rates Between Interchanges -
2 Axle Vehicles Only
SR 408 (EAST-WEST EXPRESSWAY)**

(Effective July 1, 2023)

SECTION V

235

From	To								
	Old Winter Garden/Mercy/ Ortman			John Young Parkway			Tampa Avenue		
	E-PASS	CASH	Pay-By-Plate	E-PASS	CASH	Pay-By-Plate	E-PASS	CASH	Pay-By-Plate
Florida's Turnpike	-----	-----	-----	\$2.18	\$2.75	\$4.36	\$2.18	\$2.75	\$4.36
SR 50/Clarke Road	-----	-----	-----	\$2.18	\$2.75	\$4.36	\$2.18	\$2.75	\$4.36
Good Homes Road	-----	-----	-----	\$2.18	\$2.75	\$4.36	\$2.18	\$2.75	\$4.36
Hiawassee Road	-----	-----	-----	\$1.88	\$2.25	\$3.76	\$1.88	\$2.25	\$3.76
Kirkman Road	-----	-----	-----	\$1.25	\$1.50	\$2.50	\$1.25	\$1.50	\$2.50
Pine Hills Road	-----	-----	-----	\$1.25	\$1.50	\$2.50	\$1.25	\$1.50	\$2.50
Old Winter Garden/Mercy-Ortman Drive	-----	-----	-----	\$0.93	\$1.25	\$1.86	\$0.93	\$1.25	\$1.86
John Young Parkway	\$0.93	\$1.25	\$1.86	-----	-----	-----	\$0.93	\$1.25	\$1.86
Tampa Avenue	\$0.93	\$1.25	\$1.86	\$0.93	\$1.25	\$1.86	-----	-----	-----
Orange Blossom Trail	\$0.93	\$1.25	\$1.86	\$0.93	\$1.25	\$1.86	-----	-----	-----
Interstate 4 (I-4)	\$0.93	\$1.25	\$1.86	\$0.93	\$1.25	\$1.86	-----	-----	-----
Orange Avenue	\$0.93	\$1.25	\$1.86	\$0.93	\$1.25	\$1.86	-----	-----	-----
Rosalind Avenue	-----	-----	-----	-----	-----	-----	-----	-----	-----
Mills Avenue	-----	-----	-----	-----	-----	-----	-----	-----	-----
Bumby Avenue	\$1.56	\$2.00	\$3.12	\$1.56	\$2.00	\$3.12	-----	-----	-----
Crystal Lake Drive	-----	-----	-----	-----	-----	-----	-----	-----	-----
Conway Road	\$1.86	\$2.50	\$3.72	\$1.86	\$2.50	\$3.72	-----	-----	-----
Andes Avenue	\$2.18	\$2.75	\$4.36	\$2.18	\$2.75	\$4.36	-----	-----	-----
Semoran Boulevard (SR 436)	\$2.18	\$2.75	\$4.36	\$2.18	\$2.75	\$4.36	-----	-----	-----
Yucatan Drive	-----	-----	-----	-----	-----	-----	-----	-----	-----
Goldenrod Road	\$2.18	\$2.75	\$4.36	\$2.18	\$2.75	\$4.36	-----	-----	-----
Chickasaw Trail	\$2.18	\$2.75	\$4.36	\$2.18	\$2.75	\$4.36	-----	-----	-----
SR 417 (GreeneWay)	\$2.18	\$2.75	\$4.36	\$2.18	\$2.75	\$4.36	-----	-----	-----
Dean Road	\$2.81	\$3.50	\$5.62	\$2.81	\$3.50	\$5.62	-----	-----	-----
Rouse Road	\$3.11	\$4.00	\$6.22	\$3.11	\$4.00	\$6.22	-----	-----	-----
Alafaya Trail	\$3.11	\$4.00	\$6.22	\$3.11	\$4.00	\$6.22	-----	-----	-----
SR 50 (East Colonial Drive)	\$3.11	\$4.00	\$6.22	\$3.11	\$4.00	\$6.22	-----	-----	-----



**Toll Rates Between Interchanges -
2 Axle Vehicles Only**
SR 408 (EAST-WEST EXPRESSWAY)

(Effective July 1, 2023)

SECTION V

236

From	To								
	Orange Blossom Trail			Interstate 4 (I-4)			Orange Avenue		
	E-PASS	CASH	Pay-By-Plate	E-PASS	CASH	Pay-By-Plate	E-PASS	CASH	Pay-By-Plate
Florida's Turnpike	\$2.18	\$2.75	\$4.36	\$2.18	\$2.75	\$4.36	\$2.18	\$2.75	\$4.36
SR 50/Clarke Road	\$2.18	\$2.75	\$4.36	\$2.18	\$2.75	\$4.36	\$2.18	\$2.75	\$4.36
Good Homes Road	\$2.18	\$2.75	\$4.36	\$2.18	\$2.75	\$4.36	\$2.18	\$2.75	\$4.36
Hiawassee Road	\$1.88	\$2.25	\$3.76	\$1.88	\$2.25	\$3.76	\$1.88	\$2.25	\$3.76
Kirkman Road	\$1.25	\$1.50	\$2.50	\$1.25	\$1.50	\$2.50	\$1.25	\$1.50	\$2.50
Pine Hills Road	\$1.25	\$1.50	\$2.50	\$1.25	\$1.50	\$2.50	\$1.25	\$1.50	\$2.50
Old Winter Garden/Mercy-Ortman Drive	\$0.93	\$1.25	\$1.86	\$0.93	\$1.25	\$1.86	\$0.93	\$1.25	\$1.86
John Young Parkway	\$0.93	\$1.25	\$1.86	\$0.93	\$1.25	\$1.86	\$0.93	\$1.25	\$1.86
Tampa Avenue	-----	-----	-----	-----	-----	-----	-----	-----	-----
Orange Blossom Trail	-----	-----	-----	\$0.63	\$0.75	\$1.26	\$0.63	\$0.75	\$1.26
Interstate 4 (I-4)	\$0.63	\$0.75	\$1.26	-----	-----	-----	-----	-----	-----
Orange Avenue	\$0.63	\$0.75	\$1.26	-----	-----	-----	-----	-----	-----
Rosalind Avenue	-----	-----	-----	-----	-----	-----	-----	-----	-----
Mills Avenue	-----	-----	-----	-----	-----	-----	-----	-----	-----
Bumby Avenue	\$1.26	\$1.50	\$2.52	\$0.63	\$0.75	\$1.26	-----	-----	-----
Crystal Lake Drive	-----	-----	-----	-----	-----	-----	-----	-----	-----
Conway Road	\$1.56	\$2.00	\$3.12	\$0.93	\$1.25	\$1.86	-----	-----	-----
Andes Avenue	\$1.88	\$2.25	\$3.76	\$1.25	\$1.50	\$2.50	-----	-----	-----
Semoran Boulevard (SR 436)	\$1.88	\$2.25	\$3.76	\$1.25	\$1.50	\$2.50	-----	-----	-----
Yucatan Drive	-----	-----	-----	-----	-----	-----	-----	-----	-----
Goldenrod Road	\$1.88	\$2.25	\$3.76	\$1.25	\$1.50	\$2.50	-----	-----	-----
Chickasaw Trail	\$1.88	\$2.25	\$3.76	\$1.25	\$1.50	\$2.50	-----	-----	-----
SR 417 (GreeneWay)	\$1.88	\$2.25	\$3.76	\$1.25	\$1.50	\$2.50	-----	-----	-----
Dean Road	\$2.51	\$3.00	\$5.02	\$1.88	\$2.25	\$3.76	-----	-----	-----
Rouse Road	\$2.81	\$3.50	\$5.62	\$2.18	\$2.75	\$4.36	-----	-----	-----
Alafaya Trail	\$2.81	\$3.50	\$5.62	\$2.18	\$2.75	\$4.36	-----	-----	-----
SR 50 (East Colonial Drive)	\$2.81	\$3.50	\$5.62	\$2.18	\$2.75	\$4.36	-----	-----	-----



**Toll Rates Between Interchanges -
2 Axle Vehicles Only
SR 408 (EAST-WEST EXPRESSWAY)**

(Effective July 1, 2023)

SECTION V

237

From	To								
	Rosalind Avenue			Mills Avenue			Bumby Avenue		
	E-PASS	CASH	Pay-By-Plate	E-PASS	CASH	Pay-By-Plate	E-PASS	CASH	Pay-By-Plate
Florida's Turnpike	-----	-----	-----	\$2.81	\$3.50	\$5.62	\$2.81	\$3.50	\$5.62
SR 50/Clarke Road	-----	-----	-----	\$2.81	\$3.50	\$5.62	\$2.81	\$3.50	\$5.62
Good Homes Road	-----	-----	-----	\$2.81	\$3.50	\$5.62	\$2.81	\$3.50	\$5.62
Hiawassee Road	-----	-----	-----	\$2.51	\$3.00	\$5.02	\$2.51	\$3.00	\$5.02
Kirkman Road	-----	-----	-----	\$1.88	\$2.25	\$3.76	\$1.88	\$2.25	\$3.76
Pine Hills Road	-----	-----	-----	\$1.88	\$2.25	\$3.76	\$1.88	\$2.25	\$3.76
Old Winter Garden/Mercy-Ortman Drive	-----	-----	-----	\$1.56	\$2.00	\$3.12	\$1.56	\$2.00	\$3.12
John Young Parkway	-----	-----	-----	\$1.56	\$2.00	\$3.12	\$1.56	\$2.00	\$3.12
Tampa Avenue	-----	-----	-----	-----	-----	-----	-----	-----	-----
Orange Blossom Trail	-----	-----	-----	\$1.26	\$1.50	\$2.52	\$1.26	\$1.50	\$2.52
Interstate 4 (I-4)	-----	-----	-----	\$0.63	\$0.75	\$1.26	\$0.63	\$0.75	\$1.26
Orange Avenue	-----	-----	-----	-----	-----	-----	-----	-----	-----
Rosalind Avenue	-----	-----	-----	\$0.63	\$0.75	\$1.26	\$0.63	\$0.75	\$1.26
Mills Avenue	-----	-----	-----	-----	-----	-----	\$0.63	\$0.75	\$1.26
Bumby Avenue	\$0.63	\$0.75	\$1.26	\$0.63	\$0.75	\$1.26	-----	-----	-----
Crystal Lake Drive	-----	-----	-----	-----	-----	-----	-----	-----	-----
Conway Road	\$0.93	\$1.25	\$1.86	\$0.93	\$1.25	\$1.86	-----	-----	-----
Andes Avenue	\$1.25	\$1.50	\$2.50	\$1.25	\$1.50	\$2.50	-----	-----	-----
Semorán Boulevard (SR 436)	\$1.25	\$1.50	\$2.50	\$1.25	\$1.50	\$2.50	-----	-----	-----
Yucatan Drive	-----	-----	-----	-----	-----	-----	-----	-----	-----
Goldenrod Road	\$1.25	\$1.50	\$2.50	\$1.25	\$1.50	\$2.50	-----	-----	-----
Chickasaw Trail	\$1.25	\$1.50	\$2.50	\$1.25	\$1.50	\$2.50	-----	-----	-----
SR 417 (GreeneWay)	\$1.25	\$1.50	\$2.50	\$1.25	\$1.50	\$2.50	-----	-----	-----
Dean Road	\$1.88	\$2.25	\$3.76	\$1.88	\$2.25	\$3.76	-----	-----	-----
Rouse Road	\$2.18	\$2.75	\$4.36	\$2.18	\$2.75	\$4.36	-----	-----	-----
Alafaya Trail	\$2.18	\$2.75	\$4.36	\$2.18	\$2.75	\$4.36	-----	-----	-----
SR 50 (East Colonial Drive)	\$2.18	\$2.75	\$4.36	\$2.18	\$2.75	\$4.36	-----	-----	-----



**Toll Rates Between Interchanges -
2 Axle Vehicles Only
SR 408 (EAST-WEST EXPRESSWAY)**

(Effective July 1, 2023)

From	To								
	Crystal Lake Drive			Conway Road			Andes Avenue		
	E-PASS	CASH	Pay-By-Plate	E-PASS	CASH	Pay-By-Plate	E-PASS	CASH	Pay-By-Plate
Florida's Turnpike	-----	-----	-----	\$3.11	\$4.00	\$6.22	\$3.43	\$4.25	\$6.86
SR 50/Clarke Road	-----	-----	-----	\$3.11	\$4.00	\$6.22	\$3.43	\$4.25	\$6.86
Good Homes Road	-----	-----	-----	\$3.11	\$4.00	\$6.22	\$3.43	\$4.25	\$6.86
Hiawassee Road	-----	-----	-----	\$2.81	\$3.50	\$5.62	\$3.13	\$3.75	\$6.26
Kirkman Road	-----	-----	-----	\$2.18	\$2.75	\$4.36	\$2.50	\$3.00	\$5.00
Pine Hills Road	-----	-----	-----	\$2.18	\$2.75	\$4.36	\$2.50	\$3.00	\$5.00
Old Winter Garden/Mercy-Ortman Drive	-----	-----	-----	\$1.86	\$2.50	\$3.72	\$2.18	\$2.75	\$4.36
John Young Parkway	-----	-----	-----	\$1.86	\$2.50	\$3.72	\$2.18	\$2.75	\$4.36
Tampa Avenue	-----	-----	-----	-----	-----	-----	-----	-----	-----
Orange Blossom Trail	-----	-----	-----	\$1.56	\$2.00	\$3.12	\$1.88	\$2.25	\$3.76
Interstate 4 (I-4)	-----	-----	-----	\$0.93	\$1.25	\$1.86	\$1.25	\$1.50	\$2.50
Orange Avenue	-----	-----	-----	-----	-----	-----	-----	-----	-----
Rosalind Avenue	-----	-----	-----	\$0.93	\$1.25	\$1.86	\$1.25	\$1.50	\$2.50
Mills Avenue	-----	-----	-----	\$0.93	\$1.25	\$1.86	\$1.25	\$1.50	\$2.50
Bumby Avenue	-----	-----	-----	-----	-----	-----	-----	-----	-----
Crystal Lake Drive	-----	-----	-----	\$0.93	\$1.25	\$1.86	\$1.25	\$1.50	\$2.50
Conway Road	\$0.93	\$1.25	\$1.86	-----	-----	-----	-----	-----	-----
Andes Avenue	\$1.25	\$1.50	\$2.50	-----	-----	-----	-----	-----	-----
Semoran Boulevard (SR 436)	\$1.25	\$1.50	\$2.50	-----	-----	-----	-----	-----	-----
Yucatan Drive	-----	-----	-----	-----	-----	-----	-----	-----	-----
Goldenrod Road	\$1.25	\$1.50	\$2.50	-----	-----	-----	-----	-----	-----
Chickasaw Trail	\$1.25	\$1.50	\$2.50	-----	-----	-----	-----	-----	-----
SR 417 (GreeneWay)	\$1.25	\$1.50	\$2.50	-----	-----	-----	-----	-----	-----
Dean Road	\$1.88	\$2.25	\$3.76	-----	-----	-----	-----	-----	-----
Rouse Road	\$2.18	\$2.75	\$4.36	-----	-----	-----	-----	-----	-----
Alafaya Trail	\$2.18	\$2.75	\$4.36	-----	-----	-----	-----	-----	-----
SR 50 (East Colonial Drive)	\$2.18	\$2.75	\$4.36	-----	-----	-----	-----	-----	-----



**Toll Rates Between Interchanges -
2 Axle Vehicles Only**
SR 408 (EAST-WEST EXPRESSWAY)

(Effective July 1, 2023)

SECTION V

239

From	To								
	Semoran Boulevard			Yucatan Drive			Goldenrod Road		
	E-PASS	CASH	Pay-By-Plate	E-PASS	CASH	Pay-By-Plate	E-PASS	CASH	Pay-By-Plate
Florida's Turnpike	-----	-----	-----	-----	-----	-----	\$3.43	\$4.25	\$6.86
SR 50/Clarke Road	-----	-----	-----	-----	-----	-----	\$3.43	\$4.25	\$6.86
Good Homes Road	-----	-----	-----	-----	-----	-----	\$3.43	\$4.25	\$6.86
Hiwassee Road	-----	-----	-----	-----	-----	-----	\$3.13	\$3.75	\$6.26
Kirkman Road	-----	-----	-----	-----	-----	-----	\$2.50	\$3.00	\$5.00
Pine Hills Road	-----	-----	-----	-----	-----	-----	\$2.50	\$3.00	\$5.00
Old Winter Garden/Mercy-Ortman Drive	-----	-----	-----	-----	-----	-----	\$2.18	\$2.75	\$4.36
John Young Parkway	-----	-----	-----	-----	-----	-----	\$2.18	\$2.75	\$4.36
Tampa Avenue	-----	-----	-----	-----	-----	-----	-----	-----	-----
Orange Blossom Trail	-----	-----	-----	-----	-----	-----	\$1.88	\$2.25	\$3.76
Interstate 4 (I-4)	-----	-----	-----	-----	-----	-----	\$1.25	\$1.50	\$2.50
Orange Avenue	-----	-----	-----	-----	-----	-----	-----	-----	-----
Rosalind Avenue	-----	-----	-----	-----	-----	-----	\$1.25	\$1.50	\$2.50
Mills Avenue	-----	-----	-----	-----	-----	-----	\$1.25	\$1.50	\$2.50
Bumby Avenue	-----	-----	-----	-----	-----	-----	-----	-----	-----
Crystal Lake Drive	-----	-----	-----	-----	-----	-----	\$1.25	\$1.50	\$2.50
Conway Road	-----	-----	-----	-----	-----	-----	-----	-----	-----
Andes Avenue	-----	-----	-----	-----	-----	-----	-----	-----	-----
Semoran Boulevard (SR 436)	-----	-----	-----	-----	-----	-----	-----	-----	-----
Yucatan Drive	-----	-----	-----	-----	-----	-----	\$0.93	\$1.25	\$1.86
Goldenrod Road	\$0.93	\$1.25	\$1.86	-----	-----	-----	-----	-----	-----
Chickasaw Trail	\$0.93	\$1.25	\$1.86	-----	-----	-----	-----	-----	-----
SR 417 (GreeneWay)	\$0.93	\$1.25	\$1.86	-----	-----	-----	\$0.00	\$0.00	\$0.00
Dean Road	\$1.56	\$2.00	\$3.12	-----	-----	-----	\$0.63	\$0.75	\$1.26
Rouse Road	\$1.86	\$2.50	\$3.72	-----	-----	-----	\$0.93	\$1.25	\$1.86
Alafaya Trail	\$1.86	\$2.50	\$3.72	-----	-----	-----	\$0.93	\$1.25	\$1.86
SR 50 (East Colonial Drive)	\$1.86	\$2.50	\$3.72	-----	-----	-----	\$0.93	\$1.25	\$1.86



**Toll Rates Between Interchanges -
2 Axle Vehicles Only**
SR 408 (EAST-WEST EXPRESSWAY)

(Effective July 1, 2023)

SECTION V

240

From	To								
	Chickasaw Trail			SR 417 (GreeneWay)			Dean Road		
	E-PASS	CASH	Pay-By-Plate	E-PASS	CASH	Pay-By-Plate	E-PASS	CASH	Pay-By-Plate
Florida's Turnpike	\$3.43	\$4.25	\$6.86	\$3.43	\$4.25	\$6.86	\$4.06	\$5.00	\$8.12
SR 50/Clarke Road	\$3.43	\$4.25	\$6.86	\$3.43	\$4.25	\$6.86	\$4.06	\$5.00	\$8.12
Good Homes Road	\$3.43	\$4.25	\$6.86	\$3.43	\$4.25	\$6.86	\$4.06	\$5.00	\$8.12
Hiawassee Road	\$3.13	\$3.75	\$6.26	\$3.13	\$3.75	\$6.26	\$3.76	\$4.50	\$7.52
Kirkman Road	\$2.50	\$3.00	\$5.00	\$2.50	\$3.00	\$5.00	\$3.13	\$3.75	\$6.26
Pine Hills Road	\$2.50	\$3.00	\$5.00	\$2.50	\$3.00	\$5.00	\$3.13	\$3.75	\$6.26
Old Winter Garden/Mercy-Ortman Drive	\$2.18	\$2.75	\$4.36	\$2.18	\$2.75	\$4.36	\$2.81	\$3.50	\$5.62
John Young Parkway	\$2.18	\$2.75	\$4.36	\$2.18	\$2.75	\$4.36	\$2.81	\$3.50	\$5.62
Tampa Avenue	-----	-----	-----	-----	-----	-----	-----	-----	-----
Orange Blossom Trail	\$1.88	\$2.25	\$3.76	\$1.88	\$2.25	\$3.76	\$2.51	\$3.00	\$5.02
Interstate 4 (I-4)	\$1.25	\$1.50	\$2.50	\$1.25	\$1.50	\$2.50	\$1.88	\$2.25	\$3.76
Orange Avenue	-----	-----	-----	-----	-----	-----	-----	-----	-----
Rosalind Avenue	\$1.25	\$1.50	\$2.50	\$1.25	\$1.50	\$2.50	\$1.88	\$2.25	\$3.76
Mills Avenue	\$1.25	\$1.50	\$2.50	\$1.25	\$1.50	\$2.50	\$1.88	\$2.25	\$3.76
Bumby Avenue	-----	-----	-----	-----	-----	-----	-----	-----	-----
Crystal Lake Drive	\$1.25	\$1.50	\$2.50	\$1.25	\$1.50	\$2.50	\$1.88	\$2.25	\$3.76
Conway Road	-----	-----	-----	-----	-----	-----	-----	-----	-----
Andes Avenue	-----	-----	-----	-----	-----	-----	-----	-----	-----
Semoran Boulevard (SR 436)	-----	-----	-----	-----	-----	-----	-----	-----	-----
Yucatan Drive	\$0.93	\$1.25	\$1.86	\$0.93	\$1.25	\$1.86	\$1.56	\$2.00	\$3.12
Goldenrod Road	-----	-----	-----	\$0.00	\$0.00	\$0.00	\$0.63	\$0.75	\$1.26
Chickasaw Trail	-----	-----	-----	-----	-----	-----	-----	-----	-----
SR 417 (GreeneWay)	-----	-----	-----	-----	-----	-----	\$0.63	\$0.75	\$1.26
Dean Road	-----	-----	-----	\$0.63	\$0.75	\$1.26	-----	-----	-----
Rouse Road	-----	-----	-----	\$0.93	\$1.25	\$1.86	\$0.93	\$1.25	\$1.86
Alafaya Trail	-----	-----	-----	\$0.93	\$1.25	\$1.86	\$0.93	\$1.25	\$1.86
SR 50 (East Colonial Drive)	-----	-----	-----	\$0.93	\$1.25	\$1.86	\$0.93	\$1.25	\$1.86



**Toll Rates Between Interchanges -
2 Axle Vehicles Only
SR 408 (EAST-WEST EXPRESSWAY)**

(Effective July 1, 2023)

From	To								
	Rouse Road			Alafaya Trail			SR 50 (Colonial Drive)		
	E-PASS	CASH	Pay-By-Plate	E-PASS	CASH	Pay-By-Plate	E-PASS	CASH	Pay-By-Plate
Florida's Turnpike	\$4.36	\$5.50	\$8.72	\$4.36	\$5.50	\$8.72	\$4.36	\$5.50	\$8.72
SR 50/Clarke Road	\$4.36	\$5.50	\$8.72	\$4.36	\$5.50	\$8.72	\$4.36	\$5.50	\$8.72
Good Homes Road	\$4.36	\$5.50	\$8.72	\$4.36	\$5.50	\$8.72	\$4.36	\$5.50	\$8.72
Hiawassee Road	\$4.06	\$5.00	\$8.12	\$4.06	\$5.00	\$8.12	\$4.06	\$5.00	\$8.12
Kirkman Road	\$3.43	\$4.25	\$6.86	\$3.43	\$4.25	\$6.86	\$3.43	\$4.25	\$6.86
Pine Hills Road	\$3.43	\$4.25	\$6.86	\$3.43	\$4.25	\$6.86	\$3.43	\$4.25	\$6.86
Old Winter Garden/Mercy-Ortman Drive	\$3.11	\$4.00	\$6.22	\$3.11	\$4.00	\$6.22	\$3.11	\$4.00	\$6.22
John Young Parkway	\$3.11	\$4.00	\$6.22	\$3.11	\$4.00	\$6.22	\$3.11	\$4.00	\$6.22
Tampa Avenue	-----	-----	-----	-----	-----	-----	-----	-----	-----
Orange Blossom Trail	\$2.81	\$3.50	\$5.62	\$2.81	\$3.50	\$5.62	\$2.81	\$3.50	\$5.62
Interstate 4 (I-4)	\$2.18	\$2.75	\$4.36	\$2.18	\$2.75	\$4.36	\$2.18	\$2.75	\$4.36
Orange Avenue	-----	-----	-----	-----	-----	-----	-----	-----	-----
Rosalind Avenue	\$2.18	\$2.75	\$4.36	\$2.18	\$2.75	\$4.36	\$2.18	\$2.75	\$4.36
Mills Avenue	\$2.18	\$2.75	\$4.36	\$2.18	\$2.75	\$4.36	\$2.18	\$2.75	\$4.36
Bumby Avenue	-----	-----	-----	-----	-----	-----	-----	-----	-----
Crystal Lake Drive	\$2.18	\$2.75	\$4.36	\$2.18	\$2.75	\$4.36	\$2.18	\$2.75	\$4.36
Conway Road	-----	-----	-----	-----	-----	-----	-----	-----	-----
Andes Avenue	-----	-----	-----	-----	-----	-----	-----	-----	-----
Semoran Boulevard (SR 436)	-----	-----	-----	-----	-----	-----	-----	-----	-----
Yucatan Drive	\$1.86	\$2.50	\$3.72	\$1.86	\$2.50	\$3.72	\$1.86	\$2.50	\$3.72
Goldenrod Road	\$0.93	\$1.25	\$1.86	\$0.93	\$1.25	\$1.86	\$0.93	\$1.25	\$1.86
Chickasaw Trail	-----	-----	-----	-----	-----	-----	-----	-----	-----
SR 417 (GreeneWay)	\$0.93	\$1.25	\$1.86	\$0.93	\$1.25	\$1.86	\$0.93	\$1.25	\$1.86
Dean Road	\$0.93	\$1.25	\$1.86	\$0.93	\$1.25	\$1.86	\$0.93	\$1.25	\$1.86
Rouse Road	-----	-----	-----	\$0.63	\$0.75	\$1.26	\$0.63	\$0.75	\$1.26
Alafaya Trail	\$0.63	\$0.75	\$1.26	-----	-----	-----	-----	-----	-----
SR 50 (East Colonial Drive)	\$0.63	\$0.75	\$1.26	-----	-----	-----	-----	-----	-----



**Toll Rates Between Interchanges -
2 Axle Vehicles Only
SR 408 (EAST-WEST EXPRESSWAY)**

(Effective July 1, 2023)

From	To								
	Boggy Creek Road			Tradeport/Conway Road			Semoran Boulevard/Airport		
	E-PASS	CASH	Pay-By-Plate	E-PASS	CASH	Pay-By-Plate	E-PASS	CASH	Pay-By-Plate
US 441/Florida's Turnpike	\$2.03	\$2.75	\$3.71	\$2.03	\$2.75	\$3.71	\$2.03	\$2.75	\$3.71
Boggy Creek Road	-----	-----	-----	\$1.25	\$1.50	\$2.50	\$1.25	\$1.50	\$2.50
Tradeport Drive/Conway Road	\$1.25	\$1.50	\$2.50	-----	-----	-----	\$1.25	\$1.50	\$2.50
Semoran Boulevard/Airport	\$1.25	\$1.50	\$2.50	\$1.25	\$1.50	\$2.50	-----	-----	-----
Goldenrod Road	\$1.25	\$1.50	\$2.50	\$1.25	\$1.50	\$2.50	\$0.00	\$0.00	\$0.00
Narcoossee Road	\$1.25	\$1.50	\$2.50	\$1.25	\$1.50	\$2.50	\$0.00	\$0.00	\$0.00
SR 417 (GreeneWay)	\$1.25	\$1.50	\$2.50	\$1.25	\$1.50	\$2.50	\$0.00	\$0.00	\$0.00
Innovation Way	\$2.24	\$2.75	\$4.48	\$2.24	\$2.75	\$4.48	\$0.99	\$1.25	\$1.98
Dallas Boulevard	\$2.82	\$3.50	\$5.64	\$2.82	\$3.50	\$5.64	\$1.57	\$2.00	\$3.14
SR 520	\$3.08	\$4.25	\$6.39	\$3.08	\$4.25	\$6.39	\$1.83	\$2.75	\$3.89
Brevard County Line	\$3.08	\$4.25	\$6.39	\$3.08	\$4.25	\$6.39	\$1.83	\$2.75	\$3.89

From	To								
	Goldenrod Road			Narcoossee Road			SR 417 (GreeneWay)		
	E-PASS	CASH	Pay-By-Plate	E-PASS	CASH	Pay-By-Plate	E-PASS	CASH	Pay-By-Plate
US 441/Florida's Turnpike	\$2.03	\$2.75	\$3.71	\$2.03	\$2.75	\$3.71	\$2.03	\$2.75	\$3.71
Boggy Creek Road	\$1.25	\$1.50	\$2.50	\$1.25	\$1.50	\$2.50	\$1.25	\$1.50	\$2.50
Tradeport Drive/Conway Road	\$1.25	\$1.50	\$2.50	\$1.25	\$1.50	\$2.50	\$1.25	\$1.50	\$2.50
Semoran Boulevard/Airport	\$0.00	\$0.00	\$0.00	\$0.00	\$0.00	\$0.00	\$0.00	\$0.00	\$0.00
Goldenrod Road	-----	-----	-----	\$0.00	\$0.00	\$0.00	\$0.00	\$0.00	\$0.00
Narcoossee Road	\$0.00	\$0.00	\$0.00	-----	-----	-----	\$0.00	\$0.00	\$0.00
SR 417 (GreeneWay)	\$0.00	\$0.00	\$0.00	\$0.00	\$0.00	\$0.00	-----	-----	-----
Innovation Way	\$0.99	\$1.25	\$1.98	\$0.99	\$1.25	\$1.98	\$0.99	\$1.25	\$1.98
Dallas Boulevard	\$1.57	\$2.00	\$3.14	\$1.57	\$2.00	\$3.14	\$1.57	\$2.00	\$3.14
SR 520	\$1.83	\$2.75	\$3.89	\$1.83	\$2.75	\$3.89	\$1.83	\$2.75	\$3.89
Brevard County Line	\$1.83	\$2.75	\$3.89	\$1.83	\$2.75	\$3.89	\$1.83	\$2.75	\$3.89



**Toll Rates Between Interchanges -
2 Axle Vehicles Only
SR 528 (BEACHLINE EXPRESSWAY)**

(Effective July 1, 2023)

From	To					
	Innovation Way			Dallas Boulevard		
	E-PASS	CASH	Pay-By-Plate	E-PASS	CASH	Pay-By-Plate
US 441/Florida's Turnpike	\$3.02	\$4.00	\$5.69	\$3.60	\$4.75	\$6.85
Boggy Creek Road	\$2.24	\$2.75	\$4.48	\$2.82	\$3.50	\$5.64
Tradeport Drive/Conway Road	\$2.24	\$2.75	\$4.48	\$2.82	\$3.50	\$5.64
Semoran Boulevard/Airport	\$0.99	\$1.25	\$1.98	\$1.57	\$2.00	\$3.14
Goldenrod Road	\$0.99	\$1.25	\$1.98	\$1.57	\$2.00	\$3.14
Narcoossee Road	\$0.99	\$1.25	\$1.98	\$1.57	\$2.00	\$3.14
SR 417 (GreeneWay)	\$0.99	\$1.25	\$1.98	\$1.57	\$2.00	\$3.14
Innovation Way	-----	-----	-----	\$1.25	\$1.50	\$2.50
Dallas Boulevard	\$1.25	\$1.50	\$2.50	-----	-----	-----
SR 520	\$1.51	\$2.25	\$3.25	-----	-----	-----
Brevard County Line	\$1.51	\$2.25	\$3.25	-----	-----	-----

From	To					
	SR 520			Brevard County Line		
	E-PASS	CASH	Pay-By-Plate	E-PASS	CASH	Pay-By-Plate
US 441/Florida's Turnpike	\$3.86	\$5.50	\$7.60	\$3.86	\$5.50	\$7.60
Boggy Creek Road	\$3.08	\$4.25	\$6.39	\$3.08	\$4.25	\$6.39
Tradeport Drive/Conway Road	\$3.08	\$4.25	\$6.39	\$3.08	\$4.25	\$6.39
Semoran Boulevard/Airport	\$1.83	\$2.75	\$3.89	\$1.83	\$2.75	\$3.89
Goldenrod Road	\$1.83	\$2.75	\$3.89	\$1.83	\$2.75	\$3.89
Narcoossee Road	\$1.83	\$2.75	\$3.89	\$1.83	\$2.75	\$3.89
SR 417 (GreeneWay)	\$1.83	\$2.75	\$3.89	\$1.83	\$2.75	\$3.89
Innovation Way	\$1.51	\$2.25	\$3.25	\$1.51	\$2.25	\$3.25
Dallas Boulevard	-----	-----	-----	-----	-----	-----
SR 520	-----	-----	-----	\$0.26	\$0.50	\$0.50
Brevard County Line	\$0.26	\$0.50	\$0.50	-----	-----	-----

From	To								
	International Drive			John Young Parkway			Orange Blossom Trail		
	E-PASS	CASH	Pay-By-Plate	E-PASS	CASH	Pay-By-Plate	E-PASS	CASH	Pay-By-Plate
International Drive	-----	-----	-----	\$1.56	\$1.75	\$3.12	\$1.56	\$1.75	\$3.12
John Young Parkway	\$1.56	\$1.75	\$3.12	-----	-----	-----	\$0.93	\$1.25	\$1.86
Orange Blossom Trail	\$1.56	\$1.75	\$3.12	\$0.93	\$1.25	\$1.86	-----	-----	-----
Florida's Turnpike	-----	-----	-----	-----	-----	-----	-----	-----	-----
Landstar Boulevard	\$2.06	\$2.25	\$4.12	\$1.43	\$1.75	\$2.86	\$1.13	\$1.25	\$2.26
South Access Road (International Airport)	\$3.12	\$3.50	\$6.24	\$2.49	\$3.00	\$4.98	\$2.19	\$2.50	\$4.38
Boggy Creek Road	\$3.12	\$3.50	\$6.24	\$2.49	\$3.00	\$4.98	\$2.19	\$2.50	\$4.38
Lake Nona Boulevard	\$3.12	\$3.50	\$6.24	\$2.49	\$3.00	\$4.98	\$2.19	\$2.50	\$4.38
Narcoossee Road	\$3.12	\$3.50	\$6.24	\$2.49	\$3.00	\$4.98	\$2.19	\$2.50	\$4.38
Moss Park Road	\$3.12	\$3.50	\$6.24	\$2.49	\$3.00	\$4.98	\$2.19	\$2.50	\$4.38
Innovation Way	\$3.12	\$3.50	\$6.24	\$2.49	\$3.00	\$4.98	\$2.19	\$2.50	\$4.38
SR 528 (Beachline Expressway)	\$3.12	\$3.50	\$6.24	\$2.49	\$3.00	\$4.98	\$2.19	\$2.50	\$4.38
Lee Vista Boulevard	\$3.75	\$4.25	\$7.50	\$3.12	\$3.75	\$6.24	\$2.82	\$3.25	\$5.64
Curry Ford Road	\$4.05	\$4.75	\$8.10	\$3.42	\$4.25	\$6.84	\$3.12	\$3.75	\$6.24
SR 408 (East-West Expressway)	\$4.05	\$4.75	\$8.10	\$3.42	\$4.25	\$6.84	\$3.12	\$3.75	\$6.24
SR 50 (Colonial Drive)	\$4.68	\$5.50	\$9.36	\$4.05	\$5.00	\$8.10	\$3.75	\$4.50	\$7.50
University Boulevard	\$4.98	\$6.00	\$9.96	\$4.35	\$5.50	\$8.70	\$4.05	\$5.00	\$8.10
Aloma Avenue	\$5.24	\$6.75	\$10.71	\$4.61	\$6.25	\$9.45	\$4.31	\$5.75	\$8.85



**Toll Rates Between Interchanges -
2 Axle Vehicles Only**
SR 417 (CENTRAL FLORIDA GREENEWAY)

(Effective July 1, 2023)

SECTION V

245

From	To								
	Florida's Turnpike			Landstar Boulevard			South Access Road (Int'l Airport)		
	E-PASS	CASH	Pay-By-Plate	E-PASS	CASH	Pay-By-Plate	E-PASS	CASH	Pay-By-Plate
International Drive	\$1.56	\$1.75	\$3.12	\$2.06	\$2.25	\$4.12	\$3.12	\$3.50	\$6.24
John Young Parkway	\$0.93	\$1.25	\$1.86	\$1.43	\$1.75	\$2.86	\$2.49	\$3.00	\$4.98
Orange Blossom Trail	\$0.63	\$0.75	\$1.26	\$1.13	\$1.25	\$2.26	\$2.19	\$2.50	\$4.38
Florida's Turnpike	-----	-----	-----	\$0.50	\$0.50	\$1.00	\$1.56	\$1.75	\$3.12
Landstar Boulevard	\$0.50	\$0.50	\$1.00	-----	-----	-----	\$1.56	\$1.75	\$3.12
South Access Road (International Airport)	\$1.56	\$1.75	\$3.12	\$1.56	\$1.75	\$3.12	-----	-----	-----
Boggy Creek Road	\$1.56	\$1.75	\$3.12	\$1.56	\$1.75	\$3.12	-----	-----	-----
Lake Nona Boulevard	\$1.56	\$1.75	\$3.12	\$1.56	\$1.75	\$3.12	\$1.25	\$1.50	\$2.50
Narcoossee Road	\$1.56	\$1.75	\$3.12	\$1.56	\$1.75	\$3.12	\$1.25	\$1.50	\$2.50
Moss Park Road	\$1.56	\$1.75	\$3.12	\$1.56	\$1.75	\$3.12	\$1.25	\$1.50	\$2.50
Innovation Way	\$1.56	\$1.75	\$3.12	\$1.56	\$1.75	\$3.12	\$1.25	\$1.50	\$2.50
SR 528 (Beachline Expressway)	\$1.56	\$1.75	\$3.12	\$1.56	\$1.75	\$3.12	\$1.25	\$1.50	\$2.50
Lee Vista Boulevard	\$2.19	\$2.50	\$4.38	\$2.19	\$2.50	\$4.38	\$1.88	\$2.25	\$3.76
Curry Ford Road	\$2.49	\$3.00	\$4.98	\$2.49	\$3.00	\$4.98	\$2.18	\$2.75	\$4.36
SR 408 (East-West Expressway)	\$2.49	\$3.00	\$4.98	\$2.49	\$3.00	\$4.98	\$2.18	\$2.75	\$4.36
SR 50 (Colonial Drive)	\$3.12	\$3.75	\$6.24	\$3.12	\$3.75	\$6.24	\$2.81	\$3.50	\$5.62
University Boulevard	\$3.42	\$4.25	\$6.84	\$3.42	\$4.25	\$6.84	\$3.11	\$4.00	\$6.22
Aloma Avenue	\$3.68	\$5.00	\$7.59	\$3.68	\$5.00	\$7.59	\$3.37	\$4.75	\$6.97



**Toll Rates Between Interchanges -
2 Axle Vehicles Only**
SR 417 (CENTRAL FLORIDA GREENEWAY)

(Effective July 1, 2023)

From	To								
	Boggy Creek Road			Lake Nona Boulevard			Narcoossee Road		
	E-PASS	CASH	Pay-By-Plate	E-PASS	CASH	Pay-By-Plate	E-PASS	CASH	Pay-By-Plate
International Drive	\$3.12	\$3.50	\$6.24	\$3.12	\$3.50	\$6.24	\$3.12	\$3.50	\$6.24
John Young Parkway	\$2.49	\$3.00	\$4.98	\$2.49	\$3.00	\$4.98	\$2.49	\$3.00	\$4.98
Orange Blossom Trail	\$2.19	\$2.50	\$4.38	\$2.19	\$2.50	\$4.38	\$2.19	\$2.50	\$4.38
Florida's Turnpike	\$1.56	\$1.75	\$3.12	\$1.56	\$1.75	\$3.12	\$1.56	\$1.75	\$3.12
Landstar Boulevard	\$1.56	\$1.75	\$3.12	\$1.56	\$1.75	\$3.12	\$1.56	\$1.75	\$3.12
South Access Road (International Airport)	-----	-----	-----	\$1.25	\$1.50	\$2.50	\$1.25	\$1.50	\$2.50
Boggy Creek Road	-----	-----	-----	\$1.25	\$1.50	\$2.50	\$1.25	\$1.50	\$2.50
Lake Nona Boulevard	\$1.25	\$1.50	\$2.50	-----	-----	-----	\$0.93	\$1.25	\$1.86
Narcoossee Road	\$1.25	\$1.50	\$2.50	\$0.93	\$1.25	\$1.86	-----	-----	-----
Moss Park Road	\$1.25	\$1.50	\$2.50	\$0.93	\$1.25	\$1.86	\$0.93	\$1.25	\$1.86
Innovation Way	\$1.25	\$1.50	\$2.50	\$0.93	\$1.25	\$1.86	\$0.93	\$1.25	\$1.86
SR 528 (Beachline Expressway)	\$1.25	\$1.50	\$2.50	\$0.93	\$1.25	\$1.86	\$0.93	\$1.25	\$1.86
Lee Vista Boulevard	\$1.88	\$2.25	\$3.76	\$1.56	\$2.00	\$3.12	\$1.56	\$2.00	\$3.12
Curry Ford Road	\$2.18	\$2.75	\$4.36	\$1.86	\$2.50	\$3.72	\$1.86	\$2.50	\$3.72
SR 408 (East-West Expressway)	\$2.18	\$2.75	\$4.36	\$1.86	\$2.50	\$3.72	\$1.86	\$2.50	\$3.72
SR 50 (Colonial Drive)	\$2.81	\$3.50	\$5.62	\$2.49	\$3.25	\$4.98	\$2.49	\$3.25	\$4.98
University Boulevard	\$3.11	\$4.00	\$6.22	\$2.79	\$3.75	\$5.58	\$2.79	\$3.75	\$5.58
Aloma Avenue	\$3.37	\$4.75	\$6.97	\$3.05	\$4.50	\$6.33	\$3.05	\$4.50	\$6.33



**Toll Rates Between Interchanges -
2 Axle Vehicles Only**
SR 417 (CENTRAL FLORIDA GREENEWAY)

(Effective July 1, 2023)

From	To								
	Moss Park Road			Innovation Way			SR 528 (Beachline)		
	E-PASS	CASH	Pay-By-Plate	E-PASS	CASH	Pay-By-Plate	E-PASS	CASH	Pay-By-Plate
International Drive	\$3.12	\$3.50	\$6.24	\$3.12	\$3.50	\$6.24	\$3.12	\$3.50	\$6.24
John Young Parkway	\$2.49	\$3.00	\$4.98	\$2.49	\$3.00	\$4.98	\$2.49	\$3.00	\$4.98
Orange Blossom Trail	\$2.19	\$2.50	\$4.38	\$2.19	\$2.50	\$4.38	\$2.19	\$2.50	\$4.38
Florida's Turnpike	\$1.56	\$1.75	\$3.12	\$1.56	\$1.75	\$3.12	\$1.56	\$1.75	\$3.12
Landstar Boulevard	\$1.56	\$1.75	\$3.12	\$1.56	\$1.75	\$3.12	\$1.56	\$1.75	\$3.12
South Access Road (International Airport)	\$1.25	\$1.50	\$2.50	\$1.25	\$1.50	\$2.50	\$1.25	\$1.50	\$2.50
Boggy Creek Road	\$1.25	\$1.50	\$2.50	\$1.25	\$1.50	\$2.50	\$1.25	\$1.50	\$2.50
Lake Nona Boulevard	\$0.93	\$1.25	\$1.86	\$0.93	\$1.25	\$1.86	\$0.93	\$1.25	\$1.86
Narcoossee Road	\$0.93	\$1.25	\$1.86	\$0.93	\$1.25	\$1.86	\$0.93	\$1.25	\$1.86
Moss Park Road	-----	-----	-----	\$0.63	\$0.75	\$1.26	\$0.63	\$0.75	\$1.26
Innovation Way	\$0.63	\$0.75	\$1.26	-----	-----	-----	\$0.63	\$0.75	\$1.26
SR 528 (Beachline Expressway)	\$0.63	\$0.75	\$1.26	\$0.63	\$0.75	\$1.26	-----	-----	-----
Lee Vista Boulevard	\$1.26	\$1.50	\$2.52	\$1.26	\$1.50	\$2.52	\$0.63	\$0.75	\$1.26
Curry Ford Road	\$1.56	\$2.00	\$3.12	\$1.56	\$2.00	\$3.12	\$0.93	\$1.25	\$1.86
SR 408 (East-West Expressway)	\$1.56	\$2.00	\$3.12	\$1.56	\$2.00	\$3.12	\$0.93	\$1.25	\$1.86
SR 50 (Colonial Drive)	\$2.19	\$2.75	\$4.38	\$2.19	\$2.75	\$4.38	\$1.56	\$2.00	\$3.12
University Boulevard	\$2.49	\$3.25	\$4.98	\$2.49	\$3.25	\$4.98	\$1.86	\$2.50	\$3.72
Aloma Avenue	\$2.75	\$4.00	\$5.73	\$2.75	\$4.00	\$5.73	\$2.12	\$3.25	\$4.47



**Toll Rates Between Interchanges -
2 Axle Vehicles Only**
SR 417 (CENTRAL FLORIDA GREENEWAY)

(Effective July 1, 2023)

From	To								
	Lee Vista Boulevard			Curry Ford Road			SR 408 (East West)		
	E-PASS	CASH	Pay-By-Plate	E-PASS	CASH	Pay-By-Plate	E-PASS	CASH	Pay-By-Plate
International Drive	\$3.75	\$4.25	\$7.50	\$4.05	\$4.75	\$8.10	\$4.05	\$4.75	\$8.10
John Young Parkway	\$3.12	\$3.75	\$6.24	\$3.42	\$4.25	\$6.84	\$3.42	\$4.25	\$6.84
Orange Blossom Trail	\$2.82	\$3.25	\$5.64	\$3.12	\$3.75	\$6.24	\$3.12	\$3.75	\$6.24
Florida's Turnpike	\$2.19	\$2.50	\$4.38	\$2.49	\$3.00	\$4.98	\$2.49	\$3.00	\$4.98
Landstar Boulevard	\$2.19	\$2.50	\$4.38	\$2.49	\$3.00	\$4.98	\$2.49	\$3.00	\$4.98
South Access Road (International Airport)	\$1.88	\$2.25	\$3.76	\$2.18	\$2.75	\$4.36	\$2.18	\$2.75	\$4.36
Boggy Creek Road	\$1.88	\$2.25	\$3.76	\$2.18	\$2.75	\$4.36	\$2.18	\$2.75	\$4.36
Lake Nona Boulevard	\$1.56	\$2.00	\$3.12	\$1.86	\$2.50	\$3.72	\$1.86	\$2.50	\$3.72
Narcoossee Road	\$1.56	\$2.00	\$3.12	\$1.86	\$2.50	\$3.72	\$1.86	\$2.50	\$3.72
Moss Park Road	\$1.26	\$1.50	\$2.52	\$1.56	\$2.00	\$3.12	\$1.56	\$2.00	\$3.12
Innovation Way	\$1.26	\$1.50	\$2.52	\$1.56	\$2.00	\$3.12	\$1.56	\$2.00	\$3.12
SR 528 (Beachline Expressway)	\$0.63	\$0.75	\$1.26	\$0.93	\$1.25	\$1.86	\$0.93	\$1.25	\$1.86
Lee Vista Boulevard	-----	-----	-----	\$0.93	\$1.25	\$1.86	\$0.93	\$1.25	\$1.86
Curry Ford Road	\$0.93	\$1.25	\$1.86	-----	-----	-----	\$0.63	\$0.75	\$1.26
SR 408 (East-West Expressway)	\$0.93	\$1.25	\$1.86	\$0.63	\$0.75	\$1.26	-----	-----	-----
SR 50 (Colonial Drive)	\$1.56	\$2.00	\$3.12	\$1.26	\$1.50	\$2.52	\$0.63	\$0.75	\$1.26
University Boulevard	\$1.86	\$2.50	\$3.72	\$1.56	\$2.00	\$3.12	\$0.93	\$1.25	\$1.86
Aloma Avenue	\$2.12	\$3.25	\$4.47	\$1.82	\$2.75	\$3.87	\$1.19	\$2.00	\$2.61



**Toll Rates Between Interchanges -
2 Axle Vehicles Only**
SR 417 (CENTRAL FLORIDA GREENEWAY)

(Effective July 1, 2023)

From	To								
	SR 50 (Colonial Drive)			University Boulevard			Aloma Avenue		
	E-PASS	CASH	Pay-By-Plate	E-PASS	CASH	Pay-By-Plate	E-PASS	CASH	Pay-By-Plate
International Drive	\$4.68	\$5.50	\$9.36	\$4.98	\$6.00	\$9.96	\$5.24	\$6.75	\$10.71
John Young Parkway	\$4.05	\$5.00	\$8.10	\$4.35	\$5.50	\$8.70	\$4.61	\$6.25	\$9.45
Orange Blossom Trail	\$3.75	\$4.50	\$7.50	\$4.05	\$5.00	\$8.10	\$4.31	\$5.75	\$8.85
Florida's Turnpike	\$3.12	\$3.75	\$6.24	\$3.42	\$4.25	\$6.84	\$3.68	\$5.00	\$7.59
Landstar Boulevard	\$3.12	\$3.75	\$6.24	\$3.42	\$4.25	\$6.84	\$3.68	\$5.00	\$7.59
South Access Road (International Airport)	\$2.81	\$3.50	\$5.62	\$3.11	\$4.00	\$6.22	\$3.37	\$4.75	\$6.97
Boggy Creek Road	\$2.81	\$3.50	\$5.62	\$3.11	\$4.00	\$6.22	\$3.37	\$4.75	\$6.97
Lake Nona Boulevard	\$2.49	\$3.25	\$4.98	\$2.79	\$3.75	\$5.58	\$3.05	\$4.50	\$6.33
Narcoossee Road	\$2.49	\$3.25	\$4.98	\$2.79	\$3.75	\$5.58	\$3.05	\$4.50	\$6.33
Moss Park Road	\$2.19	\$2.75	\$4.38	\$2.49	\$3.25	\$4.98	\$2.75	\$4.00	\$5.73
Innovation Way	\$2.19	\$2.75	\$4.38	\$2.49	\$3.25	\$4.98	\$2.75	\$4.00	\$5.73
SR 528 (Beachline Expressway)	\$1.56	\$2.00	\$3.12	\$1.86	\$2.50	\$3.72	\$2.12	\$3.25	\$4.47
Lee Vista Boulevard	\$1.56	\$2.00	\$3.12	\$1.86	\$2.50	\$3.72	\$2.12	\$3.25	\$4.47
Curry Ford Road	\$1.26	\$1.50	\$2.52	\$1.56	\$2.00	\$3.12	\$1.82	\$2.75	\$3.87
SR 408 (East-West Expressway)	\$0.63	\$0.75	\$1.26	\$0.93	\$1.25	\$1.86	\$1.19	\$2.00	\$2.61
SR 50 (Colonial Drive)	-----	-----	-----	\$0.93	\$1.25	\$1.86	\$1.19	\$2.00	\$2.61
University Boulevard	\$0.93	\$1.25	\$1.86	-----	-----	-----	\$0.89	\$1.50	\$2.01
Aloma Avenue	\$1.19	\$2.00	\$2.61	\$0.89	\$1.50	\$2.01	-----	-----	-----



**Toll Rates Between Interchanges -
2 Axle Vehicles Only**
SR 417 (CENTRAL FLORIDA GREENEWAY)

(Effective July 1, 2023)

From	To								
	Seidel Road			Schofield Road			New Independence Parkway		
	E-PASS	CASH	Pay-By-Plate	E-PASS	CASH	Pay-By-Plate	E-PASS	CASH	Pay-By-Plate
Seidel Road	-----	-----	-----	-----	-----	-----	-----	-----	-----
Schofield Road	-----	-----	-----	-----	-----	-----	\$0.93	\$1.25	\$1.86
New Independence Parkway	-----	-----	-----	\$0.93	\$1.25	\$1.86	-----	-----	-----
Stoneybrook West Parkway	-----	-----	-----	-----	-----	-----	-----	-----	-----
CR 535 (Winter Garden Vineland Road)	-----	-----	-----	\$1.56	\$1.75	\$3.12	\$1.56	\$1.75	\$3.12
Florida's Turnpike (SR 91)	-----	-----	-----	\$1.56	\$1.75	\$3.12	\$1.56	\$1.75	\$3.12
SR 50 (West Colonial Drive)	-----	-----	-----	\$1.56	\$1.75	\$3.12	\$1.56	\$1.75	\$3.12
Plant Street/Franklin Street/SR 438	-----	-----	-----	\$1.88	\$2.25	\$3.76	\$1.88	\$2.25	\$3.76
West Road	-----	-----	-----	\$2.49	\$3.00	\$4.98	\$2.49	\$3.00	\$4.98
CR 437A (Ocoee Apopka Road)	-----	-----	-----	\$3.12	\$3.50	\$6.24	\$3.12	\$3.50	\$6.24
SR 414 (Apopka Expressway)	-----	-----	-----	\$3.12	\$3.50	\$6.24	\$3.12	\$3.50	\$6.24
SR 429 Connector Road	-----	-----	-----	\$3.12	\$3.50	\$6.24	\$3.12	\$3.50	\$6.24
Kelly Park Road	-----	-----	-----	\$4.01	\$5.28	\$8.02	\$4.01	\$5.28	\$8.02
SR 453	-----	-----	-----	\$4.01	\$5.28	\$8.02	\$4.01	\$5.28	\$8.02
SR 46	-----	-----	-----	\$5.61	\$7.97	\$10.71	\$5.61	\$7.97	\$10.71

Notes:

1. For cash traffic passing through Ponkan and Mount Plymouth Mainline Toll Gantry Facilities, it is assumed Pay-By-Plate is used.



Toll Rates Between Interchanges - 2 Axle Vehicles Only

SR 429 (DANIEL WEBSTER WESTERN BELTWAY) (Effective July 1, 2023)

SECTION V

251

From	To								
	Stoneybrook West Parkway			CR 535			Florida's Turnpike		
	E-PASS	CASH	Pay-By-Plate	E-PASS	CASH	Pay-By-Plate	E-PASS	CASH	Pay-By-Plate
Seidel Road	-----	-----	-----	-----	-----	-----	-----	-----	-----
Schofield Road	-----	-----	-----	\$1.56	\$1.75	\$3.12	\$1.56	\$1.75	\$3.12
New Independence Parkway	-----	-----	-----	\$1.56	\$1.75	\$3.12	\$1.56	\$1.75	\$3.12
Stoneybrook West Parkway	-----	-----	-----	\$0.63	\$1.26	\$1.26	\$0.63	\$1.26	\$1.26
CR 535 (Winter Garden Vineland Road)	\$0.63	\$1.26	\$1.26	-----	-----	-----	\$0.63	\$0.75	\$1.26
Florida's Turnpike (SR 91)	\$0.63	\$1.26	\$1.26	\$0.63	\$0.75	\$1.26	-----	-----	-----
SR 50 (West Colonial Drive)	\$0.63	\$1.26	\$1.26	\$0.63	\$0.75	\$1.26	-----	-----	-----
Plant Street/Franklin Street/SR 438	\$0.95	\$1.76	\$1.90	\$0.95	\$1.25	\$1.90	\$0.32	\$0.50	\$0.64
West Road	\$1.56	\$2.51	\$3.12	\$1.56	\$2.00	\$3.12	\$0.93	\$1.25	\$1.86
CR 437A (Ocoee Apopka Road)	\$2.19	\$3.01	\$4.38	\$2.19	\$2.50	\$4.38	\$1.56	\$1.75	\$3.12
SR 414 (Apopka Expressway)	\$2.19	\$3.01	\$4.38	\$2.19	\$2.50	\$4.38	\$1.56	\$1.75	\$3.12
SR 429 Connector Road	\$2.19	\$3.01	\$4.38	\$2.19	\$2.50	\$4.38	\$1.56	\$1.75	\$3.12
Kelly Park Road	\$3.08	\$4.79	\$6.16	\$3.08	\$4.28	\$6.16	\$2.45	\$3.53	\$4.90
SR 453	\$3.08	\$4.79	\$6.16	\$3.08	\$4.28	\$6.16	\$2.45	\$3.53	\$4.90
SR 46	\$4.68	\$7.48	\$8.85	\$4.68	\$6.97	\$8.85	\$4.05	\$6.22	\$7.59

Notes:

1. For cash traffic passing through Ponkan and Mount Plymouth Mainline Toll Gantry Facilities, it is assumed Pay-By-Plate is used.



Toll Rates Between Interchanges - 2 Axle Vehicles Only

SR 429 (DANIEL WEBSTER WESTERN BELTWAY) (Effective July 1, 2023)

From	To								
	SR 50 (Colonial Drive)			Plant/Franklin Street			West Road		
	E-PASS	CASH	Pay-By-Plate	E-PASS	CASH	Pay-By-Plate	E-PASS	CASH	Pay-By-Plate
Seidel Road	-----	-----	-----	-----	-----	-----	-----	-----	-----
Schofield Road	\$1.56	\$1.75	\$3.12	\$1.88	\$2.25	\$3.76	\$2.49	\$3.00	\$4.98
New Independence Parkway	\$1.56	\$1.75	\$3.12	\$1.88	\$2.25	\$3.76	\$2.49	\$3.00	\$4.98
Stoneybrook West Parkway	\$0.63	\$1.26	\$1.26	\$0.95	\$1.76	\$1.90	\$1.56	\$2.51	\$3.12
CR 535 (Winter Garden Vineland Road)	\$0.63	\$0.75	\$1.26	\$0.95	\$1.25	\$1.90	\$1.56	\$2.00	\$3.12
Florida's Turnpike (SR 91)	-----	-----	-----	\$0.32	\$0.50	\$0.64	\$0.93	\$1.25	\$1.86
SR 50 (West Colonial Drive)	-----	-----	-----	\$0.32	\$0.50	\$0.64	\$0.93	\$1.25	\$1.86
Plant Street/Franklin Street/SR 438	\$0.32	\$0.50	\$0.64	-----	-----	-----	\$0.93	\$1.25	\$1.86
West Road	\$0.93	\$1.25	\$1.86	\$0.93	\$1.25	\$1.86	-----	-----	-----
CR 437A (Ocoee Apopka Road)	\$1.56	\$1.75	\$3.12	\$1.56	\$1.75	\$3.12	\$1.56	\$1.75	\$3.12
SR 414 (Apopka Expressway)	\$1.56	\$1.75	\$3.12	\$1.56	\$1.75	\$3.12	\$1.56	\$1.75	\$3.12
SR 429 Connector Road	\$1.56	\$1.75	\$3.12	\$1.56	\$1.75	\$3.12	\$1.56	\$1.75	\$3.12
Kelly Park Road	\$2.45	\$3.53	\$4.90	\$2.45	\$3.53	\$4.90	\$2.45	\$3.53	\$4.90
SR 453	\$2.45	\$3.53	\$4.90	\$2.45	\$3.53	\$4.90	\$2.45	\$3.53	\$4.90
SR 46	\$4.05	\$6.22	\$7.59	\$4.05	\$6.22	\$7.59	\$4.05	\$6.22	\$7.59

Notes:

1. For cash traffic passing through Ponkan and Mount Plymouth Mainline Toll Gantry Facilities, it is assumed Pay-By-Plate is used.



Toll Rates Between Interchanges - 2 Axle Vehicles Only

SR 429 (DANIEL WEBSTER WESTERN BELTWAY)

(Effective July 1, 2023)

SECTION V

253

From	To								
	CR 437A			SR 414 (Apopka Expressway)			SR 429 Connector Road		
	E-PASS	CASH	Pay-By-Plate	E-PASS	CASH	Pay-By-Plate	E-PASS	CASH	Pay-By-Plate
Seidel Road	-----	-----	-----	-----	-----	-----	-----	-----	-----
Schofield Road	\$3.12	\$3.50	\$6.24	\$3.12	\$3.50	\$6.24	\$3.12	\$3.50	\$6.24
New Independence Parkway	\$3.12	\$3.50	\$6.24	\$3.12	\$3.50	\$6.24	\$3.12	\$3.50	\$6.24
Stoneybrook West Parkway	\$2.19	\$3.01	\$4.38	\$2.19	\$3.01	\$4.38	\$2.19	\$3.01	\$4.38
CR 535 (Winter Garden Vineland Road)	\$2.19	\$2.50	\$4.38	\$2.19	\$2.50	\$4.38	\$2.19	\$2.50	\$4.38
Florida's Turnpike (SR 91)	\$1.56	\$1.75	\$3.12	\$1.56	\$1.75	\$3.12	\$1.56	\$1.75	\$3.12
SR 50 (West Colonial Drive)	\$1.56	\$1.75	\$3.12	\$1.56	\$1.75	\$3.12	\$1.56	\$1.75	\$3.12
Plant Street/Franklin Street/SR 438	\$1.56	\$1.75	\$3.12	\$1.56	\$1.75	\$3.12	\$1.56	\$1.75	\$3.12
West Road	\$1.56	\$1.75	\$3.12	\$1.56	\$1.75	\$3.12	\$1.56	\$1.75	\$3.12
CR 437A (Ocoee Apopka Road)	-----	-----	-----	\$0.63	\$0.75	\$1.26	\$0.63	\$0.75	\$1.26
SR 414 (Apopka Expressway)	\$0.63	\$0.75	\$1.26	-----	-----	-----	\$0.00	\$0.00	\$0.00
SR 429 Connector Road	\$0.63	\$0.75	\$1.26	\$0.00	\$0.00	\$0.00	-----	-----	-----
Kelly Park Road	\$1.52	\$2.53	\$3.04	\$0.89	\$1.78	\$1.78	\$0.89	\$1.78	\$1.78
SR 453	\$1.52	\$2.53	\$3.04	\$0.89	\$1.78	\$1.78	\$0.89	\$1.78	\$1.78
SR 46	\$3.12	\$5.22	\$5.73	\$2.49	\$4.47	\$4.47	\$2.49	\$4.47	\$4.47

Notes:

1. For cash traffic passing through Ponkan and Mount Plymouth Mainline Toll Gantry Facilities, it is assumed Pay-By-Plate is used.



Toll Rates Between Interchanges - 2 Axle Vehicles Only

SR 429 (DANIEL WEBSTER WESTERN BELTWAY) (Effective July 1, 2023)

From	To								
	Kelly Park Road			SR 453			SR 46		
	E-PASS	CASH	Pay-By-Plate	E-PASS	CASH	Pay-By-Plate	E-PASS	CASH	Pay-By-Plate
Seidel Road	-----	-----	-----	-----	-----	-----	-----	-----	-----
Schofield Road	\$4.01	\$5.28	\$8.02	\$4.01	\$5.28	\$8.02	\$5.61	\$7.97	\$10.71
New Independence Parkway	\$4.01	\$5.28	\$8.02	\$4.01	\$5.28	\$8.02	\$5.61	\$7.97	\$10.71
Stoneybrook West Parkway	\$3.08	\$4.79	\$6.16	\$3.08	\$4.79	\$6.16	\$4.68	\$7.48	\$8.85
CR 535 (Winter Garden Vineland Road)	\$3.08	\$4.28	\$6.16	\$3.08	\$4.28	\$6.16	\$4.68	\$6.97	\$8.85
Florida's Turnpike (SR 91)	\$2.45	\$3.53	\$4.90	\$2.45	\$3.53	\$4.90	\$4.05	\$6.22	\$7.59
SR 50 (West Colonial Drive)	\$2.45	\$3.53	\$4.90	\$2.45	\$3.53	\$4.90	\$4.05	\$6.22	\$7.59
Plant Street/Franklin Street/SR 438	\$2.45	\$3.53	\$4.90	\$2.45	\$3.53	\$4.90	\$4.05	\$6.22	\$7.59
West Road	\$2.45	\$3.53	\$4.90	\$2.45	\$3.53	\$4.90	\$4.05	\$6.22	\$7.59
CR 437A (Ocoee Apopka Road)	\$1.52	\$2.53	\$3.04	\$1.52	\$2.53	\$3.04	\$3.12	\$5.22	\$5.73
SR 414 (Apopka Expressway)	\$0.89	\$1.78	\$1.78	\$0.89	\$1.78	\$1.78	\$2.49	\$4.47	\$4.47
SR 429 Connector Road	\$0.89	\$1.78	\$1.78	\$0.89	\$1.78	\$1.78	\$2.49	\$4.47	\$4.47
Kelly Park Road	-----	-----	-----	\$0.00	\$0.00	\$0.00	\$1.60	\$2.69	\$2.69
SR 453	\$0.00	\$0.00	\$0.00	-----	-----	-----	\$1.60	\$2.69	\$2.69
SR 46	\$1.60	\$2.69	\$2.69	\$1.60	\$2.69	\$2.69	-----	-----	-----

Notes:

1. For cash traffic passing through Ponkan and Mount Plymouth Mainline Toll Gantry Facilities, it is assumed Pay-By-Plate is used.



Toll Rates Between Interchanges - 2 Axle Vehicles Only

SR 429 (DANIEL WEBSTER WESTERN BELTWAY) (Effective July 1, 2023)

SECTION V

255

From	To								
	SR 429 Connector Road			SR 451 (Western Beltway)			Marden Road		
	E-PASS	CASH	Pay-By-Plate	E-PASS	CASH	Pay-By-Plate	E-PASS	CASH	Pay-By-Plate
SR 429 Connector Road	-----	-----	-----	-----	-----	-----	-----	-----	-----
SR 451 (Western Beltway)	-----	-----	-----	-----	-----	-----	-----	-----	-----
Marden Road	-----	-----	-----	-----	-----	-----	-----	-----	-----
Keene Road	-----	-----	-----	-----	-----	-----	-----	-----	-----
Hiwassee Road (CR 435)	\$0.84	\$0.00	\$1.68	\$0.84	\$0.00	\$1.68	\$0.84	\$0.00	\$1.68
OBT - US 441 (East)	\$0.84	\$0.00	\$1.68	\$0.84	\$0.00	\$1.68	\$0.84	\$0.00	\$1.68
Bear Lake Road/Rose Avenue	\$0.84	\$0.00	\$1.68	\$0.84	\$0.00	\$1.68	\$0.84	\$0.00	\$1.68

From	To					
	Keene Road			Hiwassee Road		
	E-PASS	CASH	Pay-By-Plate	E-PASS	CASH	Pay-By-Plate
SR 429 Connector Road	-----	-----	-----	\$0.84	\$0.00	\$1.68
SR 451 (Western Beltway)	-----	-----	-----	\$0.84	\$0.00	\$1.68
Marden Road	-----	-----	-----	\$0.84	\$0.00	\$1.68
Keene Road	-----	-----	-----	\$0.62	\$0.75	\$1.24
Hiwassee Road (CR 435)	\$0.62	\$0.75	\$1.24	-----	-----	-----
OBT - US 441 (East)	\$0.62	\$0.75	\$1.24	\$0.32	\$0.50	\$0.64
Bear Lake Road/Rose Avenue	\$0.62	\$0.75	\$1.24	\$0.32	\$0.50	\$0.64

From	To					
	OBT - US 441 (East)			Bear Lake Road/Rose Avenue		
	E-PASS	CASH	Pay-By-Plate	E-PASS	CASH	Pay-By-Plate
SR 429 Connector Road	\$0.84	\$0.00	\$1.68	\$0.84	\$0.00	\$1.68
SR 451 (Western Beltway)	\$0.84	\$0.00	\$1.68	\$0.84	\$0.00	\$1.68
Marden Road	\$0.84	\$0.00	\$1.68	\$0.84	\$0.00	\$1.68
Keene Road	\$0.62	\$0.75	\$1.24	\$0.62	\$0.75	\$1.24
Hiwassee Road (CR 435)	\$0.32	\$0.50	\$0.64	\$0.32	\$0.50	\$0.64
OBT - US 441 (East)	-----	-----	-----	\$0.00	\$0.00	\$0.00
Bear Lake Road/Rose Avenue	\$0.00	\$0.00	\$0.00	-----	-----	-----



**Toll Rates Between Interchanges -
2 Axle Vehicles Only
SR 414 (APOPKA EXPRESSWAY)**

(Effective July 1, 2023)

From	To			
	SR 429 Interchange		SR 46	
	E-PASS	Pay-By-Plate	E-PASS	Pay-By-Plate
SR 429 Interchange	-----	-----	\$0.71	\$1.42
SR 46	\$0.71	\$1.42	-----	-----

From	To			
	Osceola/Polk Co. Line		Marigold Avenue	
	E-PASS	Pay-By-Plate	E-PASS	Pay-By-Plate
Osceola/Polk County Line	-----	-----	\$2.22	\$4.44
Marigold Avenue	\$2.22	\$4.44	-----	-----
Koa Street	\$2.77	\$5.54	-----	-----
Cypress Parkway	\$2.77	\$5.54	-----	-----

From				
	Koa Street		Cypress Parkway	
	E-PASS	Pay-By-Plate	E-PASS	Pay-By-Plate
Osceola/Polk County Line	\$2.77	\$5.54	\$2.77	\$5.54
Marigold Avenue	-----	-----	-----	-----
Koa Street	-----	-----	-----	-----
Cypress Parkway	-----	-----	-----	-----

Cost Per Mile Between Interchanges



2022 Traffic Data and Statistics Manual
CENTRAL FLORIDA EXPRESSWAY AUTHORITY

From	To								
	Florida's Turnpike			SR 50/Clarke Road			Good Homes Road		
	E-PASS	CASH	Pay-By-Plate	E-PASS	CASH	Pay-By-Plate	E-PASS	CASH	Pay-By-Plate
Florida's Turnpike	-----	-----	-----	-----	-----	-----	\$0.18	\$0.32	\$0.36
SR 50/Clarke Road	-----	-----	-----	-----	-----	-----	\$0.39	\$0.70	\$0.78
Good Homes Road	\$0.18	\$0.32	\$0.36	\$0.39	\$0.70	\$0.78	-----	-----	-----
Hiawassee Road	\$0.28	\$0.37	\$0.56	\$0.37	\$0.50	\$0.74	\$0.52	\$0.70	\$1.04
Kirkman Road	\$0.21	\$0.28	\$0.41	\$0.26	\$0.34	\$0.51	\$0.32	\$0.43	\$0.63
Pine Hills Road	-----	-----	-----	-----	-----	-----	-----	-----	-----
Old Winter Garden/Mercy-Ortman Drive	-----	-----	-----	-----	-----	-----	-----	-----	-----
John Young Parkway	\$0.30	\$0.38	\$0.60	\$0.34	\$0.43	\$0.68	\$0.38	\$0.48	\$0.77
Tampa Avenue	\$0.28	\$0.35	\$0.55	\$0.31	\$0.39	\$0.62	\$0.34	\$0.43	\$0.69
Orange Blossom Trail	\$0.26	\$0.33	\$0.52	\$0.29	\$0.36	\$0.58	\$0.32	\$0.40	\$0.64
Interstate 4 (I-4)	\$0.23	\$0.29	\$0.46	\$0.25	\$0.32	\$0.50	\$0.28	\$0.35	\$0.55
Orange Avenue	\$0.23	\$0.28	\$0.45	\$0.25	\$0.31	\$0.49	\$0.27	\$0.34	\$0.54
Rosalind Avenue	-----	-----	-----	-----	-----	-----	-----	-----	-----
Mills Avenue	-----	-----	-----	-----	-----	-----	-----	-----	-----
Bumby Avenue	\$0.25	\$0.31	\$0.50	\$0.27	\$0.34	\$0.54	\$0.29	\$0.36	\$0.58
Crystal Lake Drive	-----	-----	-----	-----	-----	-----	-----	-----	-----
Conway Road	\$0.25	\$0.32	\$0.50	\$0.27	\$0.34	\$0.54	\$0.29	\$0.37	\$0.57
Andes Avenue	\$0.26	\$0.32	\$0.52	\$0.28	\$0.34	\$0.56	\$0.29	\$0.37	\$0.59
Semoran Boulevard (SR 436)	\$0.25	\$0.31	\$0.50	\$0.27	\$0.33	\$0.53	\$0.28	\$0.35	\$0.56
Yucatan Drive	-----	-----	-----	-----	-----	-----	-----	-----	-----
Goldenrod Road	\$0.23	\$0.28	\$0.45	\$0.24	\$0.30	\$0.48	\$0.25	\$0.31	\$0.50
Chickasaw Trail	\$0.22	\$0.27	\$0.43	\$0.23	\$0.28	\$0.46	\$0.24	\$0.30	\$0.48
SR 417 (GreeneWay)	\$0.20	\$0.25	\$0.40	\$0.21	\$0.26	\$0.42	\$0.22	\$0.27	\$0.44
Dean Road	\$0.23	\$0.28	\$0.45	\$0.24	\$0.29	\$0.48	\$0.25	\$0.31	\$0.50
Rouse Road	\$0.23	\$0.29	\$0.46	\$0.24	\$0.30	\$0.48	\$0.25	\$0.31	\$0.50
Alafaya Trail	\$0.21	\$0.27	\$0.43	\$0.22	\$0.28	\$0.45	\$0.23	\$0.29	\$0.46
SR 50 (East Colonial Drive)	\$0.20	\$0.25	\$0.40	\$0.21	\$0.26	\$0.41	\$0.21	\$0.27	\$0.43



**Toll Rates Between Interchanges (\$ Toll Rate/Mile) -
2 Axle Vehicles Only
SR 408 (EAST-WEST EXPRESSWAY)**

(Effective July 1, 2023)

From	To								
	Hiawassee Road			Kirkman Road			Pine Hills Road		
	E-PASS	CASH	Pay-By-Plate	E-PASS	CASH	Pay-By-Plate	E-PASS	CASH	Pay-By-Plate
Florida's Turnpike	\$0.28	\$0.37	\$0.56	\$0.21	\$0.28	\$0.41	-----	-----	-----
SR 50/Clarke Road	\$0.37	\$0.50	\$0.74	\$0.26	\$0.34	\$0.51	-----	-----	-----
Good Homes Road	\$0.52	\$0.70	\$1.04	\$0.32	\$0.43	\$0.63	-----	-----	-----
Hiawassee Road	-----	-----	-----	\$0.55	\$0.65	\$1.10	-----	-----	-----
Kirkman Road	\$0.55	\$0.65	\$1.10	-----	-----	-----	-----	-----	-----
Pine Hills Road	-----	-----	-----	-----	-----	-----	-----	-----	-----
Old Winter Garden/Mercy-Ortman Drive	-----	-----	-----	-----	-----	-----	-----	-----	-----
John Young Parkway	\$0.48	\$0.58	\$0.96	\$0.45	\$0.54	\$0.91	\$0.58	\$0.69	\$1.16
Tampa Avenue	\$0.41	\$0.49	\$0.82	\$0.37	\$0.44	\$0.73	\$0.44	\$0.53	\$0.88
Orange Blossom Trail	\$0.37	\$0.44	\$0.74	\$0.32	\$0.38	\$0.64	\$0.37	\$0.45	\$0.75
Interstate 4 (I-4)	\$0.31	\$0.37	\$0.61	\$0.25	\$0.30	\$0.50	\$0.28	\$0.34	\$0.57
Orange Avenue	\$0.30	\$0.36	\$0.59	\$0.24	\$0.29	\$0.48	\$0.27	\$0.33	\$0.55
Rosalind Avenue	-----	-----	-----	-----	-----	-----	-----	-----	-----
Mills Avenue	-----	-----	-----	-----	-----	-----	-----	-----	-----
Bumby Avenue	\$0.32	\$0.38	\$0.64	\$0.28	\$0.34	\$0.56	\$0.31	\$0.37	\$0.61
Crystal Lake Drive	-----	-----	-----	-----	-----	-----	-----	-----	-----
Conway Road	\$0.31	\$0.38	\$0.62	\$0.27	\$0.35	\$0.55	\$0.30	\$0.37	\$0.59
Andes Avenue	\$0.32	\$0.38	\$0.64	\$0.29	\$0.34	\$0.57	\$0.31	\$0.37	\$0.62
Semorán Boulevard (SR 436)	\$0.30	\$0.36	\$0.60	\$0.27	\$0.32	\$0.54	\$0.29	\$0.35	\$0.58
Yucatan Drive	-----	-----	-----	-----	-----	-----	-----	-----	-----
Goldenrod Road	\$0.26	\$0.32	\$0.53	\$0.23	\$0.28	\$0.47	\$0.25	\$0.30	\$0.49
Chickasaw Trail	\$0.25	\$0.30	\$0.50	\$0.22	\$0.26	\$0.44	\$0.23	\$0.28	\$0.47
SR 417 (GreeneWay)	\$0.23	\$0.27	\$0.46	\$0.20	\$0.24	\$0.40	\$0.21	\$0.25	\$0.42
Dean Road	\$0.26	\$0.31	\$0.52	\$0.23	\$0.28	\$0.47	\$0.24	\$0.29	\$0.49
Rouse Road	\$0.26	\$0.32	\$0.51	\$0.23	\$0.29	\$0.47	\$0.24	\$0.30	\$0.49
Alafaya Trail	\$0.24	\$0.29	\$0.48	\$0.22	\$0.27	\$0.43	\$0.22	\$0.28	\$0.45
SR 50 (East Colonial Drive)	\$0.22	\$0.27	\$0.44	\$0.20	\$0.24	\$0.39	\$0.20	\$0.25	\$0.41



**Toll Rates Between Interchanges (\$ Toll Rate/Mile) -
2 Axle Vehicles Only
SR 408 (EAST-WEST EXPRESSWAY)**

(Effective July 1, 2023)

SECTION V

261

From	To								
	Old Winter Garden/Mercy/Ortman			John Young Parkway			Tampa Avenue		
	E-PASS	CASH	Pay-By-Plate	E-PASS	CASH	Pay-By-Plate	E-PASS	CASH	Pay-By-Plate
Florida's Turnpike	-----	-----	-----	\$0.30	\$0.38	\$0.60	\$0.28	\$0.35	\$0.55
SR 50/Clarke Road	-----	-----	-----	\$0.34	\$0.43	\$0.68	\$0.31	\$0.39	\$0.62
Good Homes Road	-----	-----	-----	\$0.38	\$0.48	\$0.77	\$0.34	\$0.43	\$0.69
Hiwassee Road	-----	-----	-----	\$0.48	\$0.58	\$0.96	\$0.41	\$0.49	\$0.82
Kirkman Road	-----	-----	-----	\$0.45	\$0.54	\$0.91	\$0.37	\$0.44	\$0.73
Pine Hills Road	-----	-----	-----	\$0.58	\$0.69	\$1.16	\$0.44	\$0.53	\$0.88
Old Winter Garden/Mercy-Ortman Drive	-----	-----	-----	\$0.86	\$1.16	\$1.73	\$0.53	\$0.72	\$1.07
John Young Parkway	\$0.86	\$1.16	\$1.73	-----	-----	-----	\$1.40	\$1.88	\$2.80
Tampa Avenue	\$0.53	\$0.72	\$1.07	\$1.40	\$1.88	\$2.80	-----	-----	-----
Orange Blossom Trail	\$0.41	\$0.55	\$0.83	\$0.79	\$1.06	\$1.58	-----	-----	-----
Interstate 4 (I-4)	\$0.28	\$0.38	\$0.56	\$0.41	\$0.56	\$0.83	-----	-----	-----
Orange Avenue	\$0.27	\$0.36	\$0.53	\$0.38	\$0.52	\$0.77	-----	-----	-----
Rosalind Avenue	-----	-----	-----	-----	-----	-----	-----	-----	-----
Mills Avenue	-----	-----	-----	-----	-----	-----	-----	-----	-----
Bumby Avenue	\$0.31	\$0.40	\$0.62	\$0.39	\$0.50	\$0.79	-----	-----	-----
Crystal Lake Drive	-----	-----	-----	-----	-----	-----	-----	-----	-----
Conway Road	\$0.30	\$0.40	\$0.59	\$0.36	\$0.48	\$0.71	-----	-----	-----
Andes Avenue	\$0.31	\$0.39	\$0.62	\$0.37	\$0.46	\$0.73	-----	-----	-----
Semorán Boulevard (SR 436)	\$0.29	\$0.36	\$0.58	\$0.34	\$0.42	\$0.67	-----	-----	-----
Yucatan Drive	-----	-----	-----	-----	-----	-----	-----	-----	-----
Goldenrod Road	\$0.24	\$0.30	\$0.48	\$0.27	\$0.34	\$0.55	-----	-----	-----
Chickasaw Trail	\$0.23	\$0.29	\$0.45	\$0.25	\$0.32	\$0.51	-----	-----	-----
SR 417 (GreeneWay)	\$0.20	\$0.25	\$0.40	\$0.22	\$0.28	\$0.45	-----	-----	-----
Dean Road	\$0.24	\$0.30	\$0.48	\$0.26	\$0.33	\$0.53	-----	-----	-----
Rouse Road	\$0.24	\$0.31	\$0.48	\$0.26	\$0.34	\$0.52	-----	-----	-----
Alafaya Trail	\$0.22	\$0.28	\$0.44	\$0.24	\$0.31	\$0.47	-----	-----	-----
SR 50 (East Colonial Drive)	\$0.20	\$0.25	\$0.39	\$0.21	\$0.27	\$0.42	-----	-----	-----



**Toll Rates Between Interchanges (\$ Toll Rate/Mile) -
2 Axle Vehicles Only
SR 408 (EAST-WEST EXPRESSWAY)**

(Effective July 1, 2023)

From	To								
	Orange Blossom Trail			Interstate 4 (I-4)			Orange Avenue		
	E-PASS	CASH	Pay-By-Plate	E-PASS	CASH	Pay-By-Plate	E-PASS	CASH	Pay-By-Plate
Florida's Turnpike	\$0.26	\$0.33	\$0.52	\$0.23	\$0.29	\$0.46	\$0.23	\$0.28	\$0.45
SR 50/Clarke Road	\$0.29	\$0.36	\$0.58	\$0.25	\$0.32	\$0.50	\$0.25	\$0.31	\$0.49
Good Homes Road	\$0.32	\$0.40	\$0.64	\$0.28	\$0.35	\$0.55	\$0.27	\$0.34	\$0.54
Hiawassee Road	\$0.37	\$0.44	\$0.74	\$0.31	\$0.37	\$0.61	\$0.30	\$0.36	\$0.59
Kirkman Road	\$0.32	\$0.38	\$0.64	\$0.25	\$0.30	\$0.50	\$0.24	\$0.29	\$0.48
Pine Hills Road	\$0.37	\$0.45	\$0.75	\$0.28	\$0.34	\$0.57	\$0.27	\$0.33	\$0.55
Old Winter Garden/Mercy-Ortman Drive	\$0.41	\$0.55	\$0.83	\$0.28	\$0.38	\$0.56	\$0.27	\$0.36	\$0.53
John Young Parkway	\$0.79	\$1.06	\$1.58	\$0.41	\$0.56	\$0.83	\$0.38	\$0.52	\$0.77
Tampa Avenue	-----	-----	-----	-----	-----	-----	-----	-----	-----
Orange Blossom Trail	-----	-----	-----	\$0.59	\$0.70	\$1.18	\$0.51	\$0.60	\$1.01
Interstate 4 (I-4)	\$0.59	\$0.70	\$1.18	-----	-----	-----	-----	-----	-----
Orange Avenue	\$0.51	\$0.60	\$1.01	-----	-----	-----	-----	-----	-----
Rosalind Avenue	-----	-----	-----	-----	-----	-----	-----	-----	-----
Mills Avenue	-----	-----	-----	-----	-----	-----	-----	-----	-----
Bumby Avenue	\$0.45	\$0.54	\$0.91	\$0.37	\$0.44	\$0.73	-----	-----	-----
Crystal Lake Drive	-----	-----	-----	-----	-----	-----	-----	-----	-----
Conway Road	\$0.39	\$0.50	\$0.77	\$0.31	\$0.42	\$0.63	-----	-----	-----
Andes Avenue	\$0.39	\$0.47	\$0.79	\$0.34	\$0.40	\$0.67	-----	-----	-----
Semoran Boulevard (SR 436)	\$0.35	\$0.42	\$0.71	\$0.29	\$0.35	\$0.59	-----	-----	-----
Yucatan Drive	-----	-----	-----	-----	-----	-----	-----	-----	-----
Goldenrod Road	\$0.28	\$0.33	\$0.55	\$0.22	\$0.26	\$0.43	-----	-----	-----
Chickasaw Trail	\$0.25	\$0.30	\$0.51	\$0.20	\$0.24	\$0.40	-----	-----	-----
SR 417 (GreeneWay)	\$0.22	\$0.26	\$0.44	\$0.17	\$0.20	\$0.33	-----	-----	-----
Dean Road	\$0.27	\$0.32	\$0.53	\$0.22	\$0.27	\$0.45	-----	-----	-----
Rouse Road	\$0.26	\$0.33	\$0.52	\$0.23	\$0.28	\$0.45	-----	-----	-----
Alafaya Trail	\$0.24	\$0.29	\$0.47	\$0.20	\$0.25	\$0.40	-----	-----	-----
SR 50 (East Colonial Drive)	\$0.21	\$0.26	\$0.42	\$0.17	\$0.22	\$0.35	-----	-----	-----



**Toll Rates Between Interchanges (\$ Toll Rate/Mile) -
2 Axle Vehicles Only
SR 408 (EAST-WEST EXPRESSWAY)**

(Effective July 1, 2023)

From	To								
	Rosalind Avenue			Mills Avenue			Bumby Avenue		
	E-PASS	CASH	Pay-By-Plate	E-PASS	CASH	Pay-By-Plate	E-PASS	CASH	Pay-By-Plate
Florida's Turnpike	-----	-----	-----	\$0.27	\$0.34	\$0.54	\$0.25	\$0.31	\$0.50
SR 50/Clarke Road	-----	-----	-----	\$0.29	\$0.36	\$0.59	\$0.27	\$0.34	\$0.54
Good Homes Road	-----	-----	-----	\$0.32	\$0.39	\$0.63	\$0.29	\$0.36	\$0.58
Hiwassee Road	-----	-----	-----	\$0.35	\$0.42	\$0.71	\$0.32	\$0.38	\$0.64
Kirkman Road	-----	-----	-----	\$0.32	\$0.38	\$0.63	\$0.28	\$0.34	\$0.56
Pine Hills Road	-----	-----	-----	\$0.35	\$0.42	\$0.70	\$0.31	\$0.37	\$0.61
Old Winter Garden/Mercy-Ortman Drive	-----	-----	-----	\$0.36	\$0.47	\$0.73	\$0.31	\$0.40	\$0.62
John Young Parkway	-----	-----	-----	\$0.49	\$0.63	\$0.98	\$0.39	\$0.50	\$0.79
Tampa Avenue	-----	-----	-----	-----	-----	-----	-----	-----	-----
Orange Blossom Trail	-----	-----	-----	\$0.62	\$0.74	\$1.25	\$0.45	\$0.54	\$0.91
Interstate 4 (I-4)	-----	-----	-----	\$0.66	\$0.78	\$1.32	\$0.37	\$0.44	\$0.73
Orange Avenue	-----	-----	-----	-----	-----	-----	-----	-----	-----
Rosalind Avenue	-----	-----	-----	\$1.27	\$1.52	\$2.55	\$0.50	\$0.60	\$1.00
Mills Avenue	-----	-----	-----	-----	-----	-----	\$0.83	\$0.98	\$1.65
Bumby Avenue	\$0.50	\$0.60	\$1.00	\$0.83	\$0.98	\$1.65	-----	-----	-----
Crystal Lake Drive	-----	-----	-----	-----	-----	-----	-----	-----	-----
Conway Road	\$0.37	\$0.50	\$0.74	\$0.46	\$0.62	\$0.93	-----	-----	-----
Andes Avenue	\$0.39	\$0.46	\$0.77	\$0.45	\$0.55	\$0.91	-----	-----	-----
Semorán Boulevard (SR 436)	\$0.33	\$0.40	\$0.66	\$0.38	\$0.46	\$0.76	-----	-----	-----
Yucatan Drive	-----	-----	-----	-----	-----	-----	-----	-----	-----
Goldenrod Road	\$0.24	\$0.28	\$0.47	\$0.26	\$0.31	\$0.52	-----	-----	-----
Chickasaw Trail	\$0.21	\$0.26	\$0.43	\$0.23	\$0.28	\$0.47	-----	-----	-----
SR 417 (GreeneWay)	\$0.18	\$0.21	\$0.35	\$0.19	\$0.23	\$0.38	-----	-----	-----
Dean Road	\$0.24	\$0.28	\$0.47	\$0.25	\$0.30	\$0.51	-----	-----	-----
Rouse Road	\$0.24	\$0.30	\$0.47	\$0.25	\$0.32	\$0.50	-----	-----	-----
Alafaya Trail	\$0.21	\$0.26	\$0.42	\$0.22	\$0.28	\$0.44	-----	-----	-----
SR 50 (East Colonial Drive)	\$0.18	\$0.23	\$0.36	\$0.19	\$0.24	\$0.38	-----	-----	-----



**Toll Rates Between Interchanges (\$ Toll Rate/Mile) -
2 Axle Vehicles Only
SR 408 (EAST-WEST EXPRESSWAY)**

(Effective July 1, 2023)

From	To								
	Crystal Lake Drive			Conway Road			Andes Avenue		
	E-PASS	CASH	Pay-By-Plate	E-PASS	CASH	Pay-By-Plate	E-PASS	CASH	Pay-By-Plate
Florida's Turnpike	-----	-----	-----	\$0.25	\$0.32	\$0.50	\$0.26	\$0.32	\$0.52
SR 50/Clarke Road	-----	-----	-----	\$0.27	\$0.34	\$0.54	\$0.28	\$0.34	\$0.56
Good Homes Road	-----	-----	-----	\$0.29	\$0.37	\$0.57	\$0.29	\$0.37	\$0.59
Hiawassee Road	-----	-----	-----	\$0.31	\$0.38	\$0.62	\$0.32	\$0.38	\$0.64
Kirkman Road	-----	-----	-----	\$0.27	\$0.35	\$0.55	\$0.29	\$0.34	\$0.57
Pine Hills Road	-----	-----	-----	\$0.30	\$0.37	\$0.59	\$0.31	\$0.37	\$0.62
Old Winter Garden/Mercy-Ortman Drive	-----	-----	-----	\$0.30	\$0.40	\$0.59	\$0.31	\$0.39	\$0.62
John Young Parkway	-----	-----	-----	\$0.36	\$0.48	\$0.71	\$0.37	\$0.46	\$0.73
Tampa Avenue	-----	-----	-----	-----	-----	-----	-----	-----	-----
Orange Blossom Trail	-----	-----	-----	\$0.39	\$0.50	\$0.77	\$0.39	\$0.47	\$0.79
Interstate 4 (I-4)	-----	-----	-----	\$0.31	\$0.42	\$0.63	\$0.34	\$0.40	\$0.67
Orange Avenue	-----	-----	-----	-----	-----	-----	-----	-----	-----
Rosalind Avenue	-----	-----	-----	\$0.37	\$0.50	\$0.74	\$0.39	\$0.46	\$0.77
Mills Avenue	-----	-----	-----	\$0.46	\$0.62	\$0.93	\$0.45	\$0.55	\$0.91
Bumby Avenue	-----	-----	-----	-----	-----	-----	-----	-----	-----
Crystal Lake Drive	-----	-----	-----	\$1.25	\$1.68	\$2.50	\$0.84	\$1.01	\$1.68
Conway Road	\$1.25	\$1.68	\$2.50	-----	-----	-----	-----	-----	-----
Andes Avenue	\$0.84	\$1.01	\$1.68	-----	-----	-----	-----	-----	-----
Semoran Boulevard (SR 436)	\$0.62	\$0.74	\$1.24	-----	-----	-----	-----	-----	-----
Yucatan Drive	-----	-----	-----	-----	-----	-----	-----	-----	-----
Goldenrod Road	\$0.35	\$0.42	\$0.71	-----	-----	-----	-----	-----	-----
Chickasaw Trail	\$0.30	\$0.37	\$0.61	-----	-----	-----	-----	-----	-----
SR 417 (GreeneWay)	\$0.23	\$0.28	\$0.47	-----	-----	-----	-----	-----	-----
Dean Road	\$0.31	\$0.37	\$0.61	-----	-----	-----	-----	-----	-----
Rouse Road	\$0.29	\$0.37	\$0.59	-----	-----	-----	-----	-----	-----
Alafaya Trail	\$0.25	\$0.32	\$0.51	-----	-----	-----	-----	-----	-----
SR 50 (East Colonial Drive)	\$0.21	\$0.27	\$0.43	-----	-----	-----	-----	-----	-----



**Toll Rates Between Interchanges (\$ Toll Rate/Mile) -
2 Axle Vehicles Only
SR 408 (EAST-WEST EXPRESSWAY)**

(Effective July 1, 2023)

From	To								
	Semoran Boulevard			Yucatan Drive			Goldenrod Road		
	E-PASS	CASH	Pay-By-Plate	E-PASS	CASH	Pay-By-Plate	E-PASS	CASH	Pay-By-Plate
Florida's Turnpike	-----	-----	-----	-----	-----	-----	\$0.23	\$0.28	\$0.45
SR 50/Clarke Road	-----	-----	-----	-----	-----	-----	\$0.24	\$0.30	\$0.48
Good Homes Road	-----	-----	-----	-----	-----	-----	\$0.25	\$0.31	\$0.50
Hiawassee Road	-----	-----	-----	-----	-----	-----	\$0.26	\$0.32	\$0.53
Kirkman Road	-----	-----	-----	-----	-----	-----	\$0.23	\$0.28	\$0.47
Pine Hills Road	-----	-----	-----	-----	-----	-----	\$0.25	\$0.30	\$0.49
Old Winter Garden/Mercy-Ortman Drive	-----	-----	-----	-----	-----	-----	\$0.24	\$0.30	\$0.48
John Young Parkway	-----	-----	-----	-----	-----	-----	\$0.27	\$0.34	\$0.55
Tampa Avenue	-----	-----	-----	-----	-----	-----	-----	-----	-----
Orange Blossom Trail	-----	-----	-----	-----	-----	-----	\$0.28	\$0.33	\$0.55
Interstate 4 (I-4)	-----	-----	-----	-----	-----	-----	\$0.22	\$0.26	\$0.43
Orange Avenue	-----	-----	-----	-----	-----	-----	-----	-----	-----
Rosalind Avenue	-----	-----	-----	-----	-----	-----	\$0.24	\$0.28	\$0.47
Mills Avenue	-----	-----	-----	-----	-----	-----	\$0.26	\$0.31	\$0.52
Bumby Avenue	-----	-----	-----	-----	-----	-----	-----	-----	-----
Crystal Lake Drive	-----	-----	-----	-----	-----	-----	\$0.35	\$0.42	\$0.71
Conway Road	-----	-----	-----	-----	-----	-----	-----	-----	-----
Andes Avenue	-----	-----	-----	-----	-----	-----	-----	-----	-----
Semoran Boulevard (SR 436)	-----	-----	-----	-----	-----	-----	-----	-----	-----
Yucatan Drive	-----	-----	-----	-----	-----	-----	\$0.75	\$1.01	\$1.51
Goldenrod Road	\$0.61	\$0.82	\$1.23	-----	-----	-----	-----	-----	-----
Chickasaw Trail	\$0.45	\$0.60	\$0.89	-----	-----	-----	-----	-----	-----
SR 417 (GreeneWay)	\$0.28	\$0.38	\$0.56	-----	-----	-----	\$0.00	\$0.00	\$0.00
Dean Road	\$0.38	\$0.48	\$0.75	-----	-----	-----	\$0.24	\$0.29	\$0.48
Rouse Road	\$0.34	\$0.46	\$0.69	-----	-----	-----	\$0.24	\$0.32	\$0.48
Alafaya Trail	\$0.28	\$0.38	\$0.56	-----	-----	-----	\$0.18	\$0.25	\$0.36
SR 50 (East Colonial Drive)	\$0.23	\$0.30	\$0.45	-----	-----	-----	\$0.14	\$0.19	\$0.28



**Toll Rates Between Interchanges (\$ Toll Rate/Mile) -
2 Axle Vehicles Only**
SR 408 (EAST-WEST EXPRESSWAY)

(Effective July 1, 2023)

SECTION V

266

From	To								
	Chickasaw Trail			SR 417 (GreeneWay)			Dean Road		
	E-PASS	CASH	Pay-By-Plate	E-PASS	CASH	Pay-By-Plate	E-PASS	CASH	Pay-By-Plate
Florida's Turnpike	\$0.22	\$0.27	\$0.43	\$0.20	\$0.25	\$0.40	\$0.23	\$0.28	\$0.45
SR 50/Clarke Road	\$0.23	\$0.28	\$0.46	\$0.21	\$0.26	\$0.42	\$0.24	\$0.29	\$0.48
Good Homes Road	\$0.24	\$0.30	\$0.48	\$0.22	\$0.27	\$0.44	\$0.25	\$0.31	\$0.50
Hiawassee Road	\$0.25	\$0.30	\$0.50	\$0.23	\$0.27	\$0.46	\$0.26	\$0.31	\$0.52
Kirkman Road	\$0.22	\$0.26	\$0.44	\$0.20	\$0.24	\$0.40	\$0.23	\$0.28	\$0.47
Pine Hills Road	\$0.23	\$0.28	\$0.47	\$0.21	\$0.25	\$0.42	\$0.24	\$0.29	\$0.49
Old Winter Garden/Mercy-Ortman Drive	\$0.23	\$0.29	\$0.45	\$0.20	\$0.25	\$0.40	\$0.24	\$0.30	\$0.48
John Young Parkway	\$0.25	\$0.32	\$0.51	\$0.22	\$0.28	\$0.45	\$0.26	\$0.33	\$0.53
Tampa Avenue	-----	-----	-----	-----	-----	-----	-----	-----	-----
Orange Blossom Trail	\$0.25	\$0.30	\$0.51	\$0.22	\$0.26	\$0.44	\$0.27	\$0.32	\$0.53
Interstate 4 (I-4)	\$0.20	\$0.24	\$0.40	\$0.17	\$0.20	\$0.33	\$0.22	\$0.27	\$0.45
Orange Avenue	-----	-----	-----	-----	-----	-----	-----	-----	-----
Rosalind Avenue	\$0.21	\$0.26	\$0.43	\$0.18	\$0.21	\$0.35	\$0.24	\$0.28	\$0.47
Mills Avenue	\$0.23	\$0.28	\$0.47	\$0.19	\$0.23	\$0.38	\$0.25	\$0.30	\$0.51
Bumby Avenue	-----	-----	-----	-----	-----	-----	-----	-----	-----
Crystal Lake Drive	\$0.30	\$0.37	\$0.61	\$0.23	\$0.28	\$0.47	\$0.31	\$0.37	\$0.61
Conway Road	-----	-----	-----	-----	-----	-----	-----	-----	-----
Andes Avenue	-----	-----	-----	-----	-----	-----	-----	-----	-----
Semorán Boulevard (SR 436)	-----	-----	-----	-----	-----	-----	-----	-----	-----
Yucatan Drive	\$0.51	\$0.69	\$1.03	\$0.31	\$0.41	\$0.61	\$0.40	\$0.52	\$0.81
Goldenrod Road	-----	-----	-----	\$0.00	\$0.00	\$0.00	\$0.24	\$0.29	\$0.48
Chickasaw Trail	-----	-----	-----	-----	-----	-----	-----	-----	-----
SR 417 (GreeneWay)	-----	-----	-----	-----	-----	-----	\$0.76	\$0.91	\$1.53
Dean Road	-----	-----	-----	\$0.76	\$0.91	\$1.53	-----	-----	-----
Rouse Road	-----	-----	-----	\$0.44	\$0.60	\$0.89	\$0.73	\$0.98	\$1.46
Alafaya Trail	-----	-----	-----	\$0.28	\$0.38	\$0.56	\$0.38	\$0.50	\$0.75
SR 50 (East Colonial Drive)	-----	-----	-----	\$0.19	\$0.25	\$0.38	\$0.23	\$0.31	\$0.45



**Toll Rates Between Interchanges (\$ Toll Rate/Mile) -
2 Axle Vehicles Only
SR 408 (EAST-WEST EXPRESSWAY)**

(Effective July 1, 2023)

From	To								
	Rouse Road			Alafaya Trail			SR 50 (Colonial Drive)		
	E-PASS	CASH	Pay-By-Plate	E-PASS	CASH	Pay-By-Plate	E-PASS	CASH	Pay-By-Plate
Florida's Turnpike	\$0.23	\$0.29	\$0.46	\$0.21	\$0.27	\$0.43	\$0.20	\$0.25	\$0.40
SR 50/Clarke Road	\$0.24	\$0.30	\$0.48	\$0.22	\$0.28	\$0.45	\$0.21	\$0.26	\$0.41
Good Homes Road	\$0.25	\$0.31	\$0.50	\$0.23	\$0.29	\$0.46	\$0.21	\$0.27	\$0.43
Hiawassee Road	\$0.26	\$0.32	\$0.51	\$0.24	\$0.29	\$0.48	\$0.22	\$0.27	\$0.44
Kirkman Road	\$0.23	\$0.29	\$0.47	\$0.22	\$0.27	\$0.43	\$0.20	\$0.24	\$0.39
Pine Hills Road	\$0.24	\$0.30	\$0.49	\$0.22	\$0.28	\$0.45	\$0.20	\$0.25	\$0.41
Old Winter Garden/Mercy-Ortman Drive	\$0.24	\$0.31	\$0.48	\$0.22	\$0.28	\$0.44	\$0.20	\$0.25	\$0.39
John Young Parkway	\$0.26	\$0.34	\$0.52	\$0.24	\$0.31	\$0.47	\$0.21	\$0.27	\$0.42
Tampa Avenue	-----	-----	-----	-----	-----	-----	-----	-----	-----
Orange Blossom Trail	\$0.26	\$0.33	\$0.52	\$0.24	\$0.29	\$0.47	\$0.21	\$0.26	\$0.42
Interstate 4 (I-4)	\$0.23	\$0.28	\$0.45	\$0.20	\$0.25	\$0.40	\$0.17	\$0.22	\$0.35
Orange Avenue	-----	-----	-----	-----	-----	-----	-----	-----	-----
Rosalind Avenue	\$0.24	\$0.30	\$0.47	\$0.21	\$0.26	\$0.42	\$0.18	\$0.23	\$0.36
Mills Avenue	\$0.25	\$0.32	\$0.50	\$0.22	\$0.28	\$0.44	\$0.19	\$0.24	\$0.38
Bumby Avenue	-----	-----	-----	-----	-----	-----	-----	-----	-----
Crystal Lake Drive	\$0.29	\$0.37	\$0.59	\$0.25	\$0.32	\$0.51	\$0.21	\$0.27	\$0.43
Conway Road	-----	-----	-----	-----	-----	-----	-----	-----	-----
Andes Avenue	-----	-----	-----	-----	-----	-----	-----	-----	-----
Semoran Boulevard (SR 436)	-----	-----	-----	-----	-----	-----	-----	-----	-----
Yucatan Drive	\$0.36	\$0.49	\$0.72	\$0.29	\$0.39	\$0.59	\$0.23	\$0.31	\$0.47
Goldenrod Road	\$0.24	\$0.32	\$0.48	\$0.18	\$0.25	\$0.36	\$0.14	\$0.19	\$0.28
Chickasaw Trail	-----	-----	-----	-----	-----	-----	-----	-----	-----
SR 417 (GreeneWay)	\$0.44	\$0.60	\$0.89	\$0.28	\$0.38	\$0.56	\$0.19	\$0.25	\$0.38
Dean Road	\$0.73	\$0.98	\$1.46	\$0.38	\$0.50	\$0.75	\$0.23	\$0.31	\$0.45
Rouse Road	-----	-----	-----	\$0.52	\$0.62	\$1.05	\$0.22	\$0.27	\$0.45
Alafaya Trail	\$0.52	\$0.62	\$1.05	-----	-----	-----	-----	-----	-----
SR 50 (East Colonial Drive)	\$0.22	\$0.27	\$0.45	-----	-----	-----	-----	-----	-----



**Toll Rates Between Interchanges (\$ Toll Rate/Mile) -
2 Axle Vehicles Only
SR 408 (EAST-WEST EXPRESSWAY)**

(Effective July 1, 2023)

From	To								
	Boggy Creek Road			Tradeport/Conway			Semoran Boulevard/Airport		
	E-PASS	CASH	Pay-By-Plate	E-PASS	CASH	Pay-By-Plate	E-PASS	CASH	Pay-By-Plate
US 441/Florida's Turnpike	\$0.57	\$0.77	\$1.04	\$0.44	\$0.59	\$0.80	\$0.33	\$0.45	\$0.60
Boggy Creek Road	-----	-----	-----	\$1.16	\$1.39	\$2.32	\$0.49	\$0.58	\$0.97
Tradeport Drive/Conway Road	\$1.16	\$1.39	\$2.32	-----	-----	-----	\$0.83	\$1.00	\$1.67
Semoran Boulevard/Airport	\$0.49	\$0.58	\$0.97	\$0.83	\$1.00	\$1.67	-----	-----	-----
Goldenrod Road	\$0.32	\$0.38	\$0.63	\$0.44	\$0.52	\$0.87	\$0.00	\$0.00	\$0.00
Narcoossee Road	\$0.24	\$0.28	\$0.47	\$0.30	\$0.36	\$0.59	\$0.00	\$0.00	\$0.00
SR 417 (GreeneWay)	\$0.17	\$0.20	\$0.34	\$0.20	\$0.24	\$0.40	\$0.00	\$0.00	\$0.00
Innovation Way	\$0.20	\$0.25	\$0.41	\$0.23	\$0.28	\$0.45	\$0.12	\$0.15	\$0.23
Dallas Boulevard	\$0.18	\$0.22	\$0.36	\$0.19	\$0.24	\$0.39	\$0.12	\$0.15	\$0.24
SR 520	\$0.14	\$0.19	\$0.28	\$0.14	\$0.20	\$0.30	\$0.09	\$0.14	\$0.19
Brevard County Line	\$0.11	\$0.15	\$0.23	\$0.12	\$0.16	\$0.24	\$0.07	\$0.11	\$0.16

From	To								
	Goldenrod Road			Narcoossee Road			SR 417 (GreeneWay)		
	E-PASS	CASH	Pay-By-Plate	E-PASS	CASH	Pay-By-Plate	E-PASS	CASH	Pay-By-Plate
US 441/Florida's Turnpike	\$0.27	\$0.37	\$0.49	\$0.23	\$0.31	\$0.42	\$0.19	\$0.25	\$0.34
Boggy Creek Road	\$0.32	\$0.38	\$0.63	\$0.24	\$0.28	\$0.47	\$0.17	\$0.20	\$0.34
Tradeport Drive/Conway Road	\$0.44	\$0.52	\$0.87	\$0.30	\$0.36	\$0.59	\$0.20	\$0.24	\$0.40
Semoran Boulevard/Airport	\$0.00	\$0.00	\$0.00	\$0.00	\$0.00	\$0.00	\$0.00	\$0.00	\$0.00
Goldenrod Road	-----	-----	-----	\$0.00	\$0.00	\$0.00	\$0.00	\$0.00	\$0.00
Narcoossee Road	\$0.00	\$0.00	\$0.00	-----	-----	-----	\$0.00	\$0.00	\$0.00
SR 417 (GreeneWay)	\$0.00	\$0.00	\$0.00	\$0.00	\$0.00	\$0.00	-----	-----	-----
Innovation Way	\$0.14	\$0.18	\$0.28	\$0.17	\$0.22	\$0.35	\$0.27	\$0.34	\$0.54
Dallas Boulevard	\$0.13	\$0.17	\$0.27	\$0.15	\$0.19	\$0.30	\$0.19	\$0.24	\$0.38
SR 520	\$0.10	\$0.15	\$0.21	\$0.11	\$0.16	\$0.22	\$0.12	\$0.18	\$0.25
Brevard County Line	\$0.08	\$0.12	\$0.16	\$0.08	\$0.12	\$0.17	\$0.09	\$0.14	\$0.19



**Toll Rates Between Interchanges (\$ Toll Rate/Mile) -
 2 Axle Vehicles Only
 SR 528 (BEACHLINE EXPRESSWAY)**

(Effective July 1, 2023)

From	To					
	Innovation Way			Dallas Boulevard		
	E-PASS	CASH	Pay-By-Plate	E-PASS	CASH	Pay-By-Plate
US 441/Florida's Turnpike	\$0.21	\$0.27	\$0.39	\$0.19	\$0.25	\$0.36
Boggy Creek Road	\$0.20	\$0.25	\$0.41	\$0.18	\$0.22	\$0.36
Tradeport Drive/Conway Road	\$0.23	\$0.28	\$0.45	\$0.19	\$0.24	\$0.39
Semoran Boulevard/Airport	\$0.12	\$0.15	\$0.23	\$0.12	\$0.15	\$0.24
Goldenrod Road	\$0.14	\$0.18	\$0.28	\$0.13	\$0.17	\$0.27
Narcoossee Road	\$0.17	\$0.22	\$0.35	\$0.15	\$0.19	\$0.30
SR 417 (GreeneWay)	\$0.27	\$0.34	\$0.54	\$0.19	\$0.24	\$0.38
Innovation Way	-----	-----	-----	\$0.27	\$0.33	\$0.54
Dallas Boulevard	\$0.27	\$0.33	\$0.54	-----	-----	-----
SR 520	\$0.13	\$0.19	\$0.28	-----	-----	-----
Brevard County Line	\$0.09	\$0.14	\$0.20	-----	-----	-----

From	To					
	SR 520			Brevard County Line		
	E-PASS	CASH	Pay-By-Plate	E-PASS	CASH	Pay-By-Plate
US 441/Florida's Turnpike	\$0.15	\$0.21	\$0.29	\$0.12	\$0.18	\$0.24
Boggy Creek Road	\$0.14	\$0.19	\$0.28	\$0.11	\$0.15	\$0.23
Tradeport Drive/Conway Road	\$0.14	\$0.20	\$0.30	\$0.12	\$0.16	\$0.24
Semoran Boulevard/Airport	\$0.09	\$0.14	\$0.19	\$0.07	\$0.11	\$0.16
Goldenrod Road	\$0.10	\$0.15	\$0.21	\$0.08	\$0.12	\$0.16
Narcoossee Road	\$0.11	\$0.16	\$0.22	\$0.08	\$0.12	\$0.17
SR 417 (GreeneWay)	\$0.12	\$0.18	\$0.25	\$0.09	\$0.14	\$0.19
Innovation Way	\$0.13	\$0.19	\$0.28	\$0.09	\$0.14	\$0.20
Dallas Boulevard	-----	-----	-----	-----	-----	-----
SR 520	-----	-----	-----	\$0.05	\$0.10	\$0.10
Brevard County Line	\$0.05	\$0.10	\$0.10	-----	-----	-----

From	To								
	International Drive			John Young Parkway			Orange Blossom Trail		
	E-PASS	CASH	Pay-By-Plate	E-PASS	CASH	Pay-By-Plate	E-PASS	CASH	Pay-By-Plate
International Drive	-----	-----	-----	\$0.37	\$0.41	\$0.74	\$0.28	\$0.31	\$0.56
John Young Parkway	\$0.37	\$0.41	\$0.74	-----	-----	-----	\$0.68	\$0.92	\$1.36
Orange Blossom Trail	\$0.28	\$0.31	\$0.56	\$0.68	\$0.92	\$1.36	-----	-----	-----
Florida's Turnpike	-----	-----	-----	-----	-----	-----	-----	-----	-----
Landstar Boulevard	\$0.26	\$0.28	\$0.52	\$0.39	\$0.47	\$0.77	\$0.48	\$0.53	\$0.96
South Access Road (International Airport)	\$0.27	\$0.31	\$0.54	\$0.34	\$0.41	\$0.69	\$0.37	\$0.43	\$0.75
Boggy Creek Road	\$0.27	\$0.31	\$0.54	\$0.34	\$0.41	\$0.69	\$0.37	\$0.43	\$0.75
Lake Nona Boulevard	\$0.23	\$0.26	\$0.46	\$0.27	\$0.32	\$0.53	\$0.28	\$0.31	\$0.55
Narcoossee Road	\$0.19	\$0.22	\$0.39	\$0.21	\$0.25	\$0.42	\$0.21	\$0.24	\$0.42
Moss Park Road	\$0.18	\$0.20	\$0.35	\$0.19	\$0.22	\$0.37	\$0.18	\$0.21	\$0.37
Innovation Way	\$0.17	\$0.19	\$0.34	\$0.17	\$0.21	\$0.35	\$0.17	\$0.19	\$0.34
SR 528 (Beachline Expressway)	\$0.15	\$0.17	\$0.31	\$0.16	\$0.19	\$0.31	\$0.15	\$0.17	\$0.30
Lee Vista Boulevard	\$0.17	\$0.19	\$0.34	\$0.18	\$0.21	\$0.35	\$0.17	\$0.20	\$0.34
Curry Ford Road	\$0.17	\$0.20	\$0.33	\$0.17	\$0.21	\$0.34	\$0.17	\$0.20	\$0.33
SR 408 (East-West Expressway)	\$0.15	\$0.18	\$0.30	\$0.15	\$0.19	\$0.30	\$0.15	\$0.17	\$0.29
SR 50 (Colonial Drive)	\$0.16	\$0.19	\$0.33	\$0.17	\$0.20	\$0.33	\$0.16	\$0.19	\$0.32
University Boulevard	\$0.16	\$0.19	\$0.32	\$0.16	\$0.21	\$0.32	\$0.16	\$0.20	\$0.32
Aloma Avenue	\$0.16	\$0.21	\$0.33	\$0.16	\$0.22	\$0.33	\$0.16	\$0.21	\$0.33



**Toll Rates Between Interchanges (\$ Toll Rate/Mile) -
2 Axle Vehicles Only**
SR 417 (CENTRAL FLORIDA GREENEWAY)

(Effective July 1, 2023)

From	To								
	Florida's Turnpike			Landstar Boulevard			South Access Road (Airport)		
	E-PASS	CASH	Pay-By-Plate	E-PASS	CASH	Pay-By-Plate	E-PASS	CASH	Pay-By-Plate
International Drive	\$0.24	\$0.27	\$0.47	\$0.26	\$0.28	\$0.52	\$0.27	\$0.31	\$0.54
John Young Parkway	\$0.40	\$0.54	\$0.80	\$0.39	\$0.47	\$0.77	\$0.34	\$0.41	\$0.69
Orange Blossom Trail	\$0.65	\$0.77	\$1.30	\$0.48	\$0.53	\$0.96	\$0.37	\$0.43	\$0.75
Florida's Turnpike	-----	-----	-----	\$0.36	\$0.36	\$0.73	\$0.32	\$0.36	\$0.64
Landstar Boulevard	\$0.36	\$0.36	\$0.73	-----	-----	-----	\$0.44	\$0.50	\$0.89
South Access Road (International Airport)	\$0.32	\$0.36	\$0.64	\$0.44	\$0.50	\$0.89	-----	-----	-----
Boggy Creek Road	\$0.32	\$0.36	\$0.64	\$0.44	\$0.50	\$0.89	-----	-----	-----
Lake Nona Boulevard	\$0.22	\$0.25	\$0.45	\$0.28	\$0.31	\$0.56	\$0.60	\$0.72	\$1.20
Narcoossee Road	\$0.16	\$0.18	\$0.33	\$0.19	\$0.21	\$0.38	\$0.27	\$0.32	\$0.54
Moss Park Road	\$0.14	\$0.16	\$0.28	\$0.16	\$0.18	\$0.32	\$0.20	\$0.25	\$0.41
Innovation Way	\$0.13	\$0.15	\$0.26	\$0.15	\$0.17	\$0.30	\$0.18	\$0.21	\$0.36
SR 528 (Beachline Expressway)	\$0.12	\$0.13	\$0.23	\$0.13	\$0.14	\$0.26	\$0.14	\$0.17	\$0.29
Lee Vista Boulevard	\$0.14	\$0.16	\$0.28	\$0.16	\$0.18	\$0.31	\$0.18	\$0.21	\$0.36
Curry Ford Road	\$0.14	\$0.17	\$0.28	\$0.15	\$0.18	\$0.30	\$0.17	\$0.21	\$0.34
SR 408 (East-West Expressway)	\$0.12	\$0.15	\$0.24	\$0.13	\$0.16	\$0.26	\$0.14	\$0.18	\$0.28
SR 50 (Colonial Drive)	\$0.14	\$0.17	\$0.28	\$0.15	\$0.18	\$0.30	\$0.16	\$0.20	\$0.33
University Boulevard	\$0.14	\$0.17	\$0.28	\$0.15	\$0.18	\$0.30	\$0.16	\$0.20	\$0.32
Aloma Avenue	\$0.14	\$0.19	\$0.29	\$0.15	\$0.20	\$0.31	\$0.16	\$0.22	\$0.33



**Toll Rates Between Interchanges (\$ Toll Rate/Mile) -
2 Axle Vehicles Only**
SR 417 (CENTRAL FLORIDA GREENEWAY)

(Effective July 1, 2023)

From	To								
	Boggy Creek Road			Lake Nona Boulevard			Narcoossee Road		
	E-PASS	CASH	Pay-By-Plate	E-PASS	CASH	Pay-By-Plate	E-PASS	CASH	Pay-By-Plate
International Drive	\$0.27	\$0.31	\$0.54	\$0.23	\$0.26	\$0.46	\$0.19	\$0.22	\$0.39
John Young Parkway	\$0.34	\$0.41	\$0.69	\$0.27	\$0.32	\$0.53	\$0.21	\$0.25	\$0.42
Orange Blossom Trail	\$0.37	\$0.43	\$0.75	\$0.28	\$0.31	\$0.55	\$0.21	\$0.24	\$0.42
Florida's Turnpike	\$0.32	\$0.36	\$0.64	\$0.22	\$0.25	\$0.45	\$0.16	\$0.18	\$0.33
Landstar Boulevard	\$0.44	\$0.50	\$0.89	\$0.28	\$0.31	\$0.56	\$0.19	\$0.21	\$0.38
South Access Road (International Airport)	-----	-----	-----	\$0.60	\$0.72	\$1.20	\$0.27	\$0.32	\$0.54
Boggy Creek Road	-----	-----	-----	\$0.60	\$0.72	\$1.20	\$0.27	\$0.32	\$0.54
Lake Nona Boulevard	\$0.60	\$0.72	\$1.20	-----	-----	-----	\$0.36	\$0.49	\$0.73
Narcoossee Road	\$0.27	\$0.32	\$0.54	\$0.36	\$0.49	\$0.73	-----	-----	-----
Moss Park Road	\$0.20	\$0.25	\$0.41	\$0.23	\$0.31	\$0.46	\$0.64	\$0.86	\$1.27
Innovation Way	\$0.18	\$0.21	\$0.36	\$0.19	\$0.25	\$0.38	\$0.39	\$0.52	\$0.78
SR 528 (Beachline Expressway)	\$0.14	\$0.17	\$0.29	\$0.14	\$0.19	\$0.28	\$0.23	\$0.31	\$0.46
Lee Vista Boulevard	\$0.18	\$0.21	\$0.36	\$0.18	\$0.24	\$0.37	\$0.26	\$0.34	\$0.53
Curry Ford Road	\$0.17	\$0.21	\$0.34	\$0.17	\$0.23	\$0.35	\$0.23	\$0.30	\$0.45
SR 408 (East-West Expressway)	\$0.14	\$0.18	\$0.28	\$0.14	\$0.19	\$0.28	\$0.17	\$0.23	\$0.34
SR 50 (Colonial Drive)	\$0.16	\$0.20	\$0.33	\$0.16	\$0.21	\$0.33	\$0.20	\$0.26	\$0.39
University Boulevard	\$0.16	\$0.20	\$0.32	\$0.16	\$0.21	\$0.32	\$0.19	\$0.25	\$0.37
Aloma Avenue	\$0.16	\$0.22	\$0.33	\$0.16	\$0.24	\$0.33	\$0.18	\$0.27	\$0.38



**Toll Rates Between Interchanges (\$ Toll Rate/Mile) -
2 Axle Vehicles Only**
SR 417 (CENTRAL FLORIDA GREENEWAY)

(Effective July 1, 2023)

From	To								
	Moss Park Road			Dowden Road			SR 528 (Beachline)		
	E-PASS	CASH	Pay-By-Plate	E-PASS	CASH	Pay-By-Plate	E-PASS	CASH	Pay-By-Plate
International Drive	\$0.18	\$0.20	\$0.35	\$0.17	\$0.19	\$0.34	\$0.15	\$0.17	\$0.31
John Young Parkway	\$0.19	\$0.22	\$0.37	\$0.17	\$0.21	\$0.35	\$0.16	\$0.19	\$0.31
Orange Blossom Trail	\$0.18	\$0.21	\$0.37	\$0.17	\$0.19	\$0.34	\$0.15	\$0.17	\$0.30
Florida's Turnpike	\$0.14	\$0.16	\$0.28	\$0.13	\$0.15	\$0.26	\$0.12	\$0.13	\$0.23
Landstar Boulevard	\$0.16	\$0.18	\$0.32	\$0.15	\$0.17	\$0.30	\$0.13	\$0.14	\$0.26
South Access Road (International Airport)	\$0.20	\$0.25	\$0.41	\$0.18	\$0.21	\$0.36	\$0.14	\$0.17	\$0.29
Boggy Creek Road	\$0.20	\$0.25	\$0.41	\$0.18	\$0.21	\$0.36	\$0.14	\$0.17	\$0.29
Lake Nona Boulevard	\$0.23	\$0.31	\$0.46	\$0.19	\$0.25	\$0.38	\$0.14	\$0.19	\$0.28
Narcoossee Road	\$0.64	\$0.86	\$1.27	\$0.39	\$0.52	\$0.78	\$0.23	\$0.31	\$0.46
Moss Park Road	-----	-----	-----	\$0.68	\$0.81	\$1.36	\$0.25	\$0.29	\$0.49
Innovation Way	\$0.68	\$0.81	\$1.36	-----	-----	-----	\$0.39	\$0.46	\$0.77
SR 528 (Beachline Expressway)	\$0.25	\$0.29	\$0.49	\$0.39	\$0.46	\$0.77	-----	-----	-----
Lee Vista Boulevard	\$0.28	\$0.34	\$0.57	\$0.36	\$0.42	\$0.71	\$0.33	\$0.39	\$0.66
Curry Ford Road	\$0.23	\$0.30	\$0.46	\$0.27	\$0.34	\$0.53	\$0.22	\$0.30	\$0.44
SR 408 (East-West Expressway)	\$0.16	\$0.21	\$0.33	\$0.18	\$0.23	\$0.36	\$0.13	\$0.18	\$0.27
SR 50 (Colonial Drive)	\$0.20	\$0.25	\$0.39	\$0.21	\$0.27	\$0.43	\$0.18	\$0.23	\$0.36
University Boulevard	\$0.19	\$0.24	\$0.37	\$0.20	\$0.26	\$0.40	\$0.17	\$0.23	\$0.34
Aloma Avenue	\$0.18	\$0.27	\$0.38	\$0.19	\$0.28	\$0.40	\$0.17	\$0.26	\$0.36



**Toll Rates Between Interchanges (\$ Toll Rate/Mile) -
2 Axle Vehicles Only**
SR 417 (CENTRAL FLORIDA GREENEWAY)

(Effective July 1, 2023)

From	To								
	Lee Vista Boulevard			Curry Ford Road			SR 408 (East-West Expressway)		
	E-PASS	CASH	Pay-By-Plate	E-PASS	CASH	Pay-By-Plate	E-PASS	CASH	Pay-By-Plate
International Drive	\$0.17	\$0.19	\$0.34	\$0.17	\$0.20	\$0.33	\$0.15	\$0.18	\$0.30
John Young Parkway	\$0.18	\$0.21	\$0.35	\$0.17	\$0.21	\$0.34	\$0.15	\$0.19	\$0.30
Orange Blossom Trail	\$0.17	\$0.20	\$0.34	\$0.17	\$0.20	\$0.33	\$0.15	\$0.17	\$0.29
Florida's Turnpike	\$0.14	\$0.16	\$0.28	\$0.14	\$0.17	\$0.28	\$0.12	\$0.15	\$0.24
Landstar Boulevard	\$0.16	\$0.18	\$0.31	\$0.15	\$0.18	\$0.30	\$0.13	\$0.16	\$0.26
South Access Road (International Airport)	\$0.18	\$0.21	\$0.36	\$0.17	\$0.21	\$0.34	\$0.14	\$0.18	\$0.28
Boggy Creek Road	\$0.18	\$0.21	\$0.36	\$0.17	\$0.21	\$0.34	\$0.14	\$0.18	\$0.28
Lake Nona Boulevard	\$0.18	\$0.24	\$0.37	\$0.17	\$0.23	\$0.35	\$0.14	\$0.19	\$0.28
Narcoossee Road	\$0.26	\$0.34	\$0.53	\$0.23	\$0.30	\$0.45	\$0.17	\$0.23	\$0.34
Moss Park Road	\$0.28	\$0.34	\$0.57	\$0.23	\$0.30	\$0.46	\$0.16	\$0.21	\$0.33
Innovation Way	\$0.36	\$0.42	\$0.71	\$0.27	\$0.34	\$0.53	\$0.18	\$0.23	\$0.36
SR 528 (Beachline Expressway)	\$0.33	\$0.39	\$0.66	\$0.22	\$0.30	\$0.44	\$0.13	\$0.18	\$0.27
Lee Vista Boulevard	-----	-----	-----	\$0.40	\$0.54	\$0.81	\$0.18	\$0.25	\$0.37
Curry Ford Road	\$0.40	\$0.54	\$0.81	-----	-----	-----	\$0.23	\$0.27	\$0.46
SR 408 (East-West Expressway)	\$0.18	\$0.25	\$0.37	\$0.23	\$0.27	\$0.46	-----	-----	-----
SR 50 (Colonial Drive)	\$0.23	\$0.30	\$0.46	\$0.29	\$0.34	\$0.57	\$0.37	\$0.44	\$0.74
University Boulevard	\$0.21	\$0.28	\$0.41	\$0.23	\$0.30	\$0.47	\$0.23	\$0.32	\$0.47
Aloma Avenue	\$0.20	\$0.31	\$0.42	\$0.22	\$0.33	\$0.47	\$0.21	\$0.36	\$0.47



**Toll Rates Between Interchanges (\$ Toll Rate/Mile) -
2 Axle Vehicles Only**
SR 417 (CENTRAL FLORIDA GREENEWAY)

(Effective July 1, 2023)

From	To								
	SR 50 (Colonial Drive)			University Boulevard			Aloma Avenue		
	E-PASS	CASH	Pay-By-Plate	E-PASS	CASH	Pay-By-Plate	E-PASS	CASH	Pay-By-Plate
International Drive	\$0.16	\$0.19	\$0.33	\$0.16	\$0.19	\$0.32	\$0.16	\$0.21	\$0.33
John Young Parkway	\$0.17	\$0.20	\$0.33	\$0.16	\$0.21	\$0.32	\$0.16	\$0.22	\$0.33
Orange Blossom Trail	\$0.16	\$0.19	\$0.32	\$0.16	\$0.20	\$0.32	\$0.16	\$0.21	\$0.33
Florida's Turnpike	\$0.14	\$0.17	\$0.28	\$0.14	\$0.17	\$0.28	\$0.14	\$0.19	\$0.29
Landstar Boulevard	\$0.15	\$0.18	\$0.30	\$0.15	\$0.18	\$0.30	\$0.15	\$0.20	\$0.31
South Access Road (International Airport)	\$0.16	\$0.20	\$0.33	\$0.16	\$0.20	\$0.32	\$0.16	\$0.22	\$0.33
Boggy Creek Road	\$0.16	\$0.20	\$0.33	\$0.16	\$0.20	\$0.32	\$0.16	\$0.22	\$0.33
Lake Nona Boulevard	\$0.16	\$0.21	\$0.33	\$0.16	\$0.21	\$0.32	\$0.16	\$0.24	\$0.33
Narcoossee Road	\$0.20	\$0.26	\$0.39	\$0.19	\$0.25	\$0.37	\$0.18	\$0.27	\$0.38
Moss Park Road	\$0.20	\$0.25	\$0.39	\$0.19	\$0.24	\$0.37	\$0.18	\$0.27	\$0.38
Innovation Way	\$0.21	\$0.27	\$0.43	\$0.20	\$0.26	\$0.40	\$0.19	\$0.28	\$0.40
SR 528 (Beachline Expressway)	\$0.18	\$0.23	\$0.36	\$0.17	\$0.23	\$0.34	\$0.17	\$0.26	\$0.36
Lee Vista Boulevard	\$0.23	\$0.30	\$0.46	\$0.21	\$0.28	\$0.41	\$0.20	\$0.31	\$0.42
Curry Ford Road	\$0.29	\$0.34	\$0.57	\$0.23	\$0.30	\$0.47	\$0.22	\$0.33	\$0.47
SR 408 (East-West Expressway)	\$0.37	\$0.44	\$0.74	\$0.23	\$0.32	\$0.47	\$0.21	\$0.36	\$0.47
SR 50 (Colonial Drive)	-----	-----	-----	\$0.41	\$0.55	\$0.82	\$0.31	\$0.51	\$0.67
University Boulevard	\$0.41	\$0.55	\$0.82	-----	-----	-----	\$0.54	\$0.92	\$1.23
Aloma Avenue	\$0.31	\$0.51	\$0.67	\$0.54	\$0.92	\$1.23	-----	-----	-----



**Toll Rates Between Interchanges (\$ Toll Rate/Mile) -
2 Axle Vehicles Only**
SR 417 (CENTRAL FLORIDA GREENEWAY)

(Effective July 1, 2023)

From	To								
	Seidel Road			Schofield Road			New Independence Pkwy		
	E-PASS	CASH	Pay-By-Plate	E-PASS	CASH	Pay-By-Plate	E-PASS	CASH	Pay-By-Plate
Seidel Road	-----	-----	-----	-----	-----	-----	-----	-----	-----
Schofield Road	-----	-----	-----	-----	-----	-----	\$0.47	\$0.64	\$0.95
New Independence Parkway	-----	-----	-----	\$0.47	\$0.64	\$0.95	-----	-----	-----
Stoneybrook West Parkway	-----	-----	-----	-----	-----	-----	-----	-----	-----
CR 535 (Winter Garden Vineland Road)	-----	-----	-----	\$0.25	\$0.28	\$0.49	\$0.36	\$0.40	\$0.71
Florida's Turnpike (SR 91)	-----	-----	-----	\$0.17	\$0.19	\$0.34	\$0.21	\$0.24	\$0.43
SR 50 (West Colonial Drive)	-----	-----	-----	\$0.16	\$0.18	\$0.32	\$0.20	\$0.23	\$0.41
Plant Street/Franklin Street/SR 438	-----	-----	-----	\$0.17	\$0.20	\$0.34	\$0.21	\$0.25	\$0.41
West Road	-----	-----	-----	\$0.18	\$0.22	\$0.37	\$0.21	\$0.26	\$0.43
CR 437A (Ocoee Apopka Road)	-----	-----	-----	\$0.19	\$0.22	\$0.39	\$0.22	\$0.25	\$0.44
SR 414 (Apopka Expressway)	-----	-----	-----	\$0.18	\$0.20	\$0.36	\$0.20	\$0.23	\$0.40
SR 429 Connector Road	-----	-----	-----	\$0.15	\$0.17	\$0.30	\$0.17	\$0.19	\$0.33
Kelly Park Road	-----	-----	-----	\$0.16	\$0.21	\$0.32	\$0.17	\$0.23	\$0.35
SR 453	-----	-----	-----	\$0.15	\$0.20	\$0.31	\$0.17	\$0.22	\$0.33
SR 46	-----	-----	-----	\$0.18	\$0.26	\$0.35	\$0.19	\$0.28	\$0.37

Notes:

1. For cash traffic passing through Ponkan and Mount Plymouth Mainline Toll Gantry Facilities, it is assumed Pay-By-Plate is used.



**Toll Rates Between Interchanges (\$ Toll Rate/Mile) -
2 Axle Vehicles Only**
SR 429 (DANIEL WEBSTER WESTERN BELTWAY) (Effective July 1, 2023)

From	To								
	Stoneybrook West Parkway			CR 535			Florida's Turnpike		
	E-PASS	CASH	Pay-By-Plate	E-PASS	CASH	Pay-By-Plate	E-PASS	CASH	Pay-By-Plate
Seidel Road	-----	-----	-----	-----	-----	-----	-----	-----	-----
Schofield Road	-----	-----	-----	\$0.25	\$0.28	\$0.49	\$0.17	\$0.19	\$0.34
New Independence Parkway	-----	-----	-----	\$0.36	\$0.40	\$0.71	\$0.21	\$0.24	\$0.43
Stoneybrook West Parkway	-----	-----	-----	\$0.50	\$0.99	\$0.99	\$0.15	\$0.30	\$0.30
CR 535 (Winter Garden Vineland Road)	\$0.50	\$0.99	\$0.99	-----	-----	-----	\$0.21	\$0.25	\$0.42
Florida's Turnpike (SR 91)	\$0.15	\$0.30	\$0.30	\$0.21	\$0.25	\$0.42	-----	-----	-----
SR 50 (West Colonial Drive)	\$0.14	\$0.28	\$0.28	\$0.19	\$0.23	\$0.38	-----	-----	-----
Plant Street/Franklin Street/SR 438	\$0.16	\$0.29	\$0.32	\$0.20	\$0.26	\$0.40	\$0.18	\$0.28	\$0.36
West Road	\$0.18	\$0.29	\$0.37	\$0.22	\$0.28	\$0.43	\$0.22	\$0.29	\$0.43
CR 437A (Ocoee Apopka Road)	\$0.20	\$0.27	\$0.40	\$0.22	\$0.26	\$0.45	\$0.23	\$0.26	\$0.46
SR 414 (Apopka Expressway)	\$0.18	\$0.24	\$0.35	\$0.20	\$0.23	\$0.39	\$0.19	\$0.21	\$0.38
SR 429 Connector Road	\$0.14	\$0.19	\$0.28	\$0.15	\$0.17	\$0.30	\$0.13	\$0.15	\$0.27
Kelly Park Road	\$0.16	\$0.24	\$0.31	\$0.17	\$0.23	\$0.33	\$0.16	\$0.23	\$0.31
SR 453	\$0.15	\$0.23	\$0.29	\$0.16	\$0.22	\$0.31	\$0.15	\$0.21	\$0.29
SR 46	\$0.18	\$0.29	\$0.34	\$0.19	\$0.28	\$0.36	\$0.19	\$0.29	\$0.35

Notes:

1. For cash traffic passing through Ponkan and Mount Plymouth Mainline Toll Gantry Facilities, it is assumed Pay-By-Plate is used.



**Toll Rates Between Interchanges (\$ Toll Rate/Mile) -
2 Axle Vehicles Only**
SR 429 (DANIEL WEBSTER WESTERN BELTWAY) (Effective July 1, 2023)

From	To								
	SR 50 (Colonial Drive)			Plant/Franklin Street			West Road		
	E-PASS	CASH	Pay-By-Plate	E-PASS	CASH	Pay-By-Plate	E-PASS	CASH	Pay-By-Plate
Seidel Road	-----	-----	-----	-----	-----	-----	-----	-----	-----
Schofield Road	\$0.16	\$0.18	\$0.32	\$0.17	\$0.20	\$0.34	\$0.18	\$0.22	\$0.37
New Independence Parkway	\$0.20	\$0.23	\$0.41	\$0.21	\$0.25	\$0.41	\$0.21	\$0.26	\$0.43
Stoneybrook West Parkway	\$0.14	\$0.28	\$0.28	\$0.16	\$0.29	\$0.32	\$0.18	\$0.29	\$0.37
CR 535 (Winter Garden Vineland Road)	\$0.19	\$0.23	\$0.38	\$0.20	\$0.26	\$0.40	\$0.22	\$0.28	\$0.43
Florida's Turnpike (SR 91)	-----	-----	-----	\$0.18	\$0.28	\$0.36	\$0.22	\$0.29	\$0.43
SR 50 (West Colonial Drive)	-----	-----	-----	\$0.22	\$0.35	\$0.44	\$0.24	\$0.32	\$0.47
Plant Street/Franklin Street/SR 438	\$0.22	\$0.35	\$0.44	-----	-----	-----	\$0.37	\$0.50	\$0.74
West Road	\$0.24	\$0.32	\$0.47	\$0.37	\$0.50	\$0.74	-----	-----	-----
CR 437A (Ocoee Apopka Road)	\$0.24	\$0.27	\$0.48	\$0.31	\$0.35	\$0.62	\$0.62	\$0.70	\$1.25
SR 414 (Apopka Expressway)	\$0.20	\$0.22	\$0.40	\$0.25	\$0.27	\$0.49	\$0.40	\$0.45	\$0.81
SR 429 Connector Road	\$0.14	\$0.16	\$0.28	\$0.16	\$0.18	\$0.32	\$0.21	\$0.24	\$0.43
Kelly Park Road	\$0.16	\$0.23	\$0.32	\$0.18	\$0.25	\$0.35	\$0.22	\$0.31	\$0.43
SR 453	\$0.15	\$0.22	\$0.30	\$0.16	\$0.24	\$0.33	\$0.20	\$0.28	\$0.39
SR 46	\$0.19	\$0.29	\$0.36	\$0.20	\$0.31	\$0.38	\$0.23	\$0.36	\$0.44

Notes:

1. For cash traffic passing through Ponkan and Mount Plymouth Mainline Toll Gantry Facilities, it is assumed Pay-By-Plate is used.



**Toll Rates Between Interchanges (\$ Toll Rate/Mile) -
2 Axle Vehicles Only**
SR 429 (DANIEL WEBSTER WESTERN BELTWAY) (Effective July 1, 2023)

From	To								
	CR 437A			SR 414 (Apopka Expressway)			SR 429 Connector Road		
	E-PASS	CASH	Pay-By-Plate	E-PASS	CASH	Pay-By-Plate	E-PASS	CASH	Pay-By-Plate
Seidel Road	-----	-----	-----	-----	-----	-----	-----	-----	-----
Schofield Road	\$0.19	\$0.22	\$0.39	\$0.18	\$0.20	\$0.36	\$0.15	\$0.17	\$0.30
New Independence Parkway	\$0.22	\$0.25	\$0.44	\$0.20	\$0.23	\$0.40	\$0.17	\$0.19	\$0.33
Stoneybrook West Parkway	\$0.20	\$0.27	\$0.40	\$0.18	\$0.24	\$0.35	\$0.14	\$0.19	\$0.28
CR 535 (Winter Garden Vineland Road)	\$0.22	\$0.26	\$0.45	\$0.20	\$0.23	\$0.39	\$0.15	\$0.17	\$0.30
Florida's Turnpike (SR 91)	\$0.23	\$0.26	\$0.46	\$0.19	\$0.21	\$0.38	\$0.13	\$0.15	\$0.27
SR 50 (West Colonial Drive)	\$0.24	\$0.27	\$0.48	\$0.20	\$0.22	\$0.40	\$0.14	\$0.16	\$0.28
Plant Street/Franklin Street/SR 438	\$0.31	\$0.35	\$0.62	\$0.25	\$0.27	\$0.49	\$0.16	\$0.18	\$0.32
West Road	\$0.62	\$0.70	\$1.25	\$0.40	\$0.45	\$0.81	\$0.21	\$0.24	\$0.43
CR 437A (Ocoee Apopka Road)	-----	-----	-----	\$0.47	\$0.56	\$0.93	\$0.13	\$0.16	\$0.26
SR 414 (Apopka Expressway)	\$0.47	\$0.56	\$0.93	-----	-----	-----	\$0.00	\$0.00	\$0.00
SR 429 Connector Road	\$0.13	\$0.16	\$0.26	\$0.00	\$0.00	\$0.00	-----	-----	-----
Kelly Park Road	\$0.17	\$0.29	\$0.34	\$0.12	\$0.24	\$0.24	\$0.22	\$0.44	\$0.44
SR 453	\$0.15	\$0.25	\$0.31	\$0.10	\$0.21	\$0.21	\$0.17	\$0.35	\$0.35
SR 46	\$0.21	\$0.35	\$0.39	\$0.19	\$0.33	\$0.33	\$0.25	\$0.45	\$0.45

Notes:

1. For cash traffic passing through Ponkan and Mount Plymouth Mainline Toll Gantry Facilities, it is assumed Pay-By-Plate is used.



**Toll Rates Between Interchanges (\$ Toll Rate/Mile) -
2 Axle Vehicles Only**
SR 429 (DANIEL WEBSTER WESTERN BELTWAY) (Effective July 1, 2023)

From	To								
	Kelly Park Road			SR 453			SR 46		
	E-PASS	CASH	Pay-By-Plate	E-PASS	CASH	Pay-By-Plate	E-PASS	CASH	Pay-By-Plate
Seidel Road	-----	-----	-----	-----	-----	-----	-----	-----	-----
Schofield Road	\$0.16	\$0.21	\$0.32	\$0.15	\$0.20	\$0.31	\$0.18	\$0.26	\$0.35
New Independence Parkway	\$0.17	\$0.23	\$0.35	\$0.17	\$0.22	\$0.33	\$0.19	\$0.28	\$0.37
Stoneybrook West Parkway	\$0.16	\$0.24	\$0.31	\$0.15	\$0.23	\$0.29	\$0.18	\$0.29	\$0.34
CR 535 (Winter Garden Vineland Road)	\$0.17	\$0.23	\$0.33	\$0.16	\$0.22	\$0.31	\$0.19	\$0.28	\$0.36
Florida's Turnpike (SR 91)	\$0.16	\$0.23	\$0.31	\$0.15	\$0.21	\$0.29	\$0.19	\$0.29	\$0.35
SR 50 (West Colonial Drive)	\$0.16	\$0.23	\$0.32	\$0.15	\$0.22	\$0.30	\$0.19	\$0.29	\$0.36
Plant Street/Franklin Street/SR 438	\$0.18	\$0.25	\$0.35	\$0.16	\$0.24	\$0.33	\$0.20	\$0.31	\$0.38
West Road	\$0.22	\$0.31	\$0.43	\$0.20	\$0.28	\$0.39	\$0.23	\$0.36	\$0.44
CR 437A (Ocoee Apopka Road)	\$0.17	\$0.29	\$0.34	\$0.15	\$0.25	\$0.31	\$0.21	\$0.35	\$0.39
SR 414 (Apopka Expressway)	\$0.12	\$0.24	\$0.24	\$0.10	\$0.21	\$0.21	\$0.19	\$0.33	\$0.33
SR 429 Connector Road	\$0.22	\$0.44	\$0.44	\$0.17	\$0.35	\$0.35	\$0.25	\$0.45	\$0.45
Kelly Park Road	-----	-----	-----	\$0.00	\$0.00	\$0.00	\$0.27	\$0.45	\$0.45
SR 453	\$0.00	\$0.00	\$0.00	-----	-----	-----	\$0.33	\$0.55	\$0.55
SR 46	\$0.27	\$0.45	\$0.45	\$0.33	\$0.55	\$0.55	-----	-----	-----

Notes:

1. For cash traffic passing through Ponkan and Mount Plymouth Mainline Toll Gantry Facilities, it is assumed Pay-By-Plate is used.



**Toll Rates Between Interchanges (\$ Toll Rate/Mile) -
2 Axle Vehicles Only**
SR 429 (DANIEL WEBSTER WESTERN BELTWAY) (Effective July 1, 2023)

SECTION V

281

From	To								
	SR 429 Connector Road			SR 451 (Western Beltway)			Marden Road		
	E-PASS	CASH	Pay-By-Plate	E-PASS	CASH	Pay-By-Plate	E-PASS	CASH	Pay-By-Plate
SR 429 Connector Road	-----	-----	-----	-----	-----	-----	-----	-----	-----
SR 451 (Western Beltway)	-----	-----	-----	-----	-----	-----	-----	-----	-----
Marden Road	-----	-----	-----	-----	-----	-----	-----	-----	-----
Keene Road	-----	-----	-----	-----	-----	-----	-----	-----	-----
Hiwassee Road (CR 435)	\$0.11	\$0.00	\$0.21	\$0.23	\$0.00	\$0.45	\$0.25	\$0.00	\$0.49
OBT - US 441 (East)	\$0.09	\$0.00	\$0.18	\$0.16	\$0.00	\$0.33	\$0.17	\$0.00	\$0.35
Bear Lake Road/Rose Avenue	\$0.08	\$0.00	\$0.17	\$0.14	\$0.00	\$0.29	\$0.15	\$0.00	\$0.30

From	To					
	Keene Road			Hiwassee Road (CR 435)		
	E-PASS	CASH	Pay-By-Plate	E-PASS	CASH	Pay-By-Plate
SR 429 Connector Road	-----	-----	-----	\$0.11	\$0.00	\$0.21
SR 451 (Western Beltway)	-----	-----	-----	\$0.23	\$0.00	\$0.45
Marden Road	-----	-----	-----	\$0.25	\$0.00	\$0.49
Keene Road	-----	-----	-----	\$0.48	\$0.58	\$0.96
Hiwassee Road (CR 435)	\$0.48	\$0.58	\$0.96	-----	-----	-----
OBT - US 441 (East)	\$0.23	\$0.27	\$0.45	\$0.22	\$0.34	\$0.44
Bear Lake Road/Rose Avenue	\$0.18	\$0.22	\$0.36	\$0.15	\$0.23	\$0.30

From	To					
	OBT - US 441 (East)			Bear Lake Road/Rose Avenue		
	E-PASS	CASH	Pay-By-Plate	E-PASS	CASH	Pay-By-Plate
SR 429 Connector Road	\$0.09	\$0.00	\$0.18	\$0.08	\$0.00	\$0.17
SR 451 (Western Beltway)	\$0.16	\$0.00	\$0.33	\$0.14	\$0.00	\$0.29
Marden Road	\$0.17	\$0.00	\$0.35	\$0.15	\$0.00	\$0.30
Keene Road	\$0.23	\$0.27	\$0.45	\$0.18	\$0.22	\$0.36
Hiwassee Road (CR 435)	\$0.22	\$0.34	\$0.44	\$0.15	\$0.23	\$0.30
OBT - US 441 (East)	-----	-----	-----	\$0.00	\$0.00	\$0.00
Bear Lake Road/Rose Avenue	\$0.00	\$0.00	\$0.00	-----	-----	-----



**Toll Rates Between Interchanges (\$ Toll Rate/Mile) -
2 Axle Vehicles Only
SR 414 (APOPKA EXPRESSWAY)**

(Effective July 1, 2023)

From	To			
	SR 429 Interchange		SR 46	
	E-PASS	Pay-By-Plate	E-PASS	Pay-By-Plate
SR 429 Interchange	-----	-----	\$0.36	\$0.72
SR 46	\$0.36	\$0.72	-----	-----

From	To			
	Osceola/Polk Co. Line		Marigold Avenue	
	E-PASS	Pay-By-Plate	E-PASS	Pay-By-Plate
Osceola/Polk County Line	-----	-----	\$0.56	\$1.12
Marigold Avenue	\$0.56	\$1.12	-----	-----
Koa Street	\$0.44	\$0.87	-----	-----
Cypress Parkway	\$0.39	\$0.77	-----	-----

From	To			
	Koa Street		Cypress Parkway	
	E-PASS	Pay-By-Plate	E-PASS	Pay-By-Plate
Osceola/Polk County Line	\$0.44	\$0.87	\$0.39	\$0.77
Marigold Avenue	-----	-----	-----	-----
Koa Street	-----	-----	-----	-----
Cypress Parkway	-----	-----	-----	-----



**Toll Rates Between Interchanges (\$ Toll Rate/Mile) -
2 Axle Vehicles Only
SR 538 (POINCIANA PARKWAY)**

(Effective July 1, 2023)