

PRELIMINARY ENGINEERING REPORT

SR 408 WESTBOUND CAPACITY IMPROVEMENTS FROM I-4 TO GOLDENROD ROAD PROJECT DEVELOPMENT & ENVIRONMENT STUDY

Prepared by:

Kimley»Horn

November 15, 2023

Table of Contents

1.0 - Project Information.....	3
2.0 – Project Background & Description	5
3.0 – Project Design Controls and Criteria.....	7
4.0 – Existing Conditions	11
5.0 – Traffic Analysis.....	41
6.0 – Alternatives Considered.....	42
7.0 – Preferred Alternative	43

List of Appendices

- Appendix A - Concept Plans
- Appendix B - Roadway Typical Sections
- Appendix C - Bridge Typical Sections
- Appendix D - Cost Estimates

1.0 - Project Information

Project Name: Westbound SR 408 Capacity Improvements from I-4 to Goldenrod Road PD&E Study

Projects Limits: Westbound SR 408 from I-4 to Goldenrod Road (**Figure 1**)

County: Orange County

Proposed Activity: Analyze and evaluate the addition of one lane along the westbound direction of SR 408 from I-4 to Bumby Avenue and SR 436 (Semoran Boulevard) to Goldenrod Road.

Responsible Agency: Central Florida Expressway Authority (CFX)

Planning Organization: CFX

Phase: Project Development & Environment (PD&E) Study

Project Contact Information:

CFX Director of Engineering

Dana Chester, PE
Central Florida Expressway Authority
4974 ORL Tower Road
Orlando, FL 32807
Office: 407-690-5000
Email: Dana.Chester@cfxway.com

CFX Project Manager

David Falk, PE
Central Florida Expressway Authority
4974 ORL Tower Road
Orlando, FL 32807
Office: 407-690-5000
Email: David.Falk@cfxway.com

Figure 1: Project Location Map

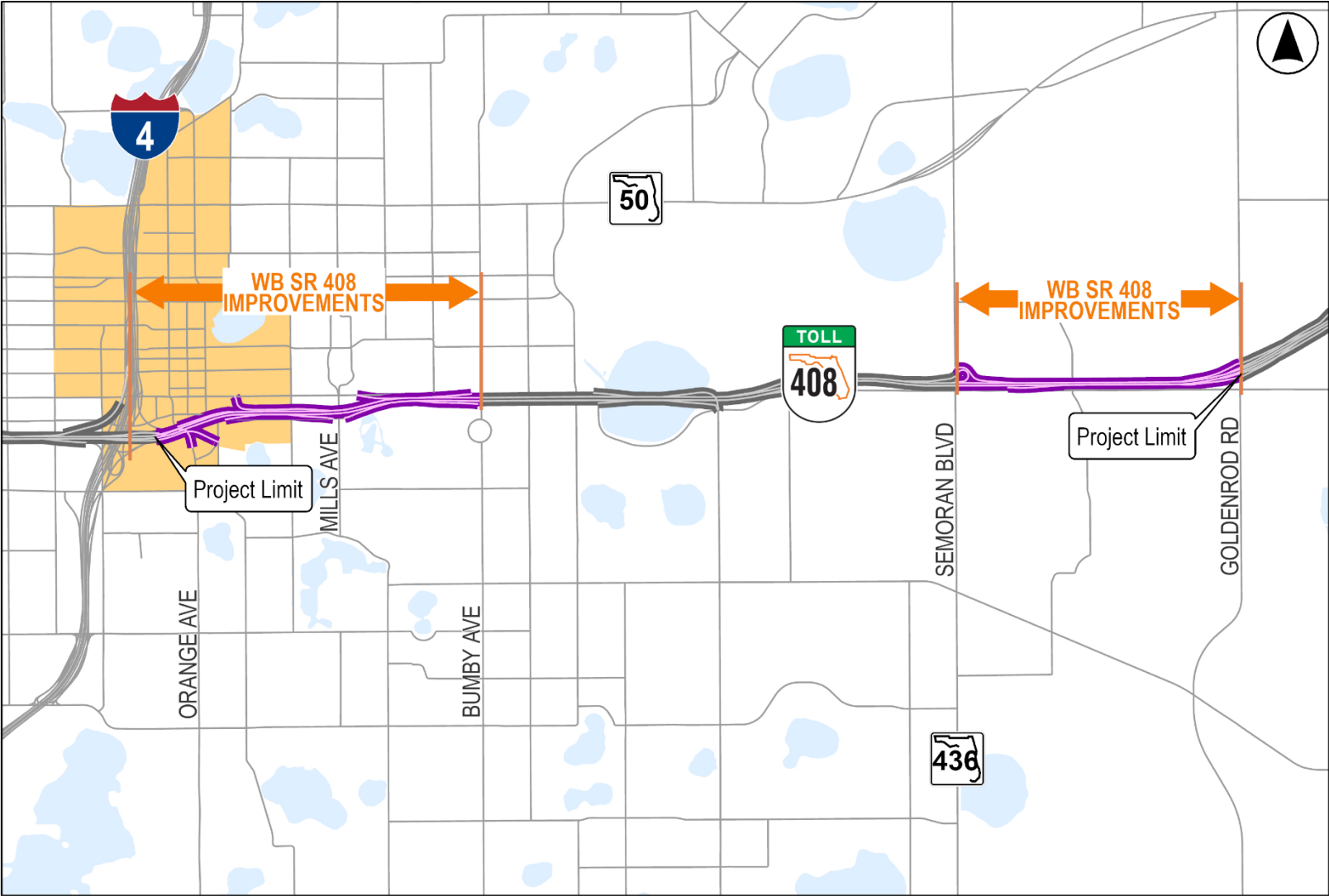

2.0 – Project Background & Description

Background

In September 2022, CFX began conducting a Project Development and Environment (PD&E) Study for capacity improvements to westbound SR 408 between Interstate 4 (I-4) and Goldenrod Road.

More than 164,000 vehicles per day travel on SR 408 with a significant portion traveling westbound in the morning from east Orlando to reach downtown and I-4. As such, the SR 408 westbound lanes near downtown Orlando become congested and experience delay. Within the study area along the westbound direction, SR 408 provides four lanes from Goldenrod Road to Semoran Boulevard, five lanes from Semoran Boulevard to Bumby Avenue, and four lanes from Bumby Avenue to I-4. An additional lane within the existing four lane segments is needed to provide five lanes continuously from Goldenrod Road to I-4 and address the mobility and traffic needs of daily commuters.

This PD&E will evaluate the addition of one westbound lane from I-4 to Bumby Avenue and from Semoran Boulevard to Goldenrod Road, matching previous improvements between Bumby Avenue and Semoran Boulevard. Most of the work would occur within SR 408's existing right of way.

Study Description

The general objective of this PD&E Study is to provide documented information necessary for CFX to reach a decision on the type, design, and location of the proposed capacity improvements within the project limits. Public involvement and community engagement will be a crucial component of this PD&E Study.

The PD&E Study includes the development and evaluation of adding a lane within the corridor. The work includes the evaluation and documentation of the physical, natural, social, and cultural environment within the corridor and the potential impacts associated with the various mobility alternatives. This analysis also addresses economic and engineering feasibility, mobility capacity and levels of service, conceptual geometry, drainage, and structures.

Purpose and Need

The purpose and need provide the basis for developing, considering, evaluating, and eliminating alternatives.

Purpose

The purpose of the study is to address increasing traffic congestion and improve mobility along the westbound lanes of SR 408 between I-4 and Goldenrod Road. With over 164,000 vehicles traveling daily in the area, the traffic volume has been steadily rising and is expected to continue growing. The project aims to improve SR 408 by adding an additional travel lane in the westbound direction from I-4 to Bumby Ave and from Semoran Boulevard to Goldenrod Road. The goal is to improve traffic flow, accommodate growing demands, reduce congestion and delay, and enhance safety.

Need

The need for adding capacity on SR 408 is based on several factors:

- 1) **Improve traffic flow:** The westbound segment of SR 408 from Semoran Boulevard to Goldenrod Road currently operates at an acceptable Level of Service (LOS) D or better

during the AM peak hour. The segment from I-4 to Bumby Avenue operates at an unacceptable LOS of E and F in the AM. As travel demands continue to increase, the LOS is expected to deteriorate if nothing is done. By 2045, travel demands on westbound SR 408 are expected to increase by over 18%.

- 2) **Reduce congestion and delay:** If nothing is done, increasing travel demands will result in more congestion and delays. This will affect the reliability of SR 408 for those who rely on it for their daily commute.
- 3) **Enhance safety:** A review of existing crash data indicates that rear end collisions account for approximately 53% of all crash types. This is indicative of increasing congestion and vehicles having to abruptly stop or slow down within a limited distance. If nothing is done, it is expected that crashes would increase.
- 4) **Support regional connectivity:** SR 408 is a vital transportation corridor connecting commuters to downtown Orlando and Interstate 4 (I-4). By enhancing the capacity and efficiency of SR 408, the improvements will contribute to regional connectivity and support economic growth and development.
- 5) **Provide consistency with local plans and policies:** Improvements to SR 408 are aligned with local plans and policies related to transportation infrastructure and land use. By providing a more efficient roadway, the project will ensure consistency with the existing land use patterns and support the area's planned growth and development.
- 6) **Support economic benefits:** Successful implementation of the study recommendations will bring economic benefits to the region. Reducing congestion and improving traffic flow will enhance logistics and other business transportation routes for goods and services. Commuters will also experience shorter travel times, leading to increased productivity and quality of life.

Other Documentation

The following documents, available under separate cover, were prepared and submitted to CFX for this PD&E Study:

- Air Quality Technical Memorandum
- Conceptual Design Roadway Plan Set
- Contamination Screening Evaluation Technical Memorandum
- Cultural Resources Desktop Analysis Technical Memorandum
- Environmental Assessment Technical Memorandum
- Existing Conditions Technical Memorandum
- Geotechnical Technical Memorandum
- Drainage Technical Memorandum
- Project Traffic Analysis Technical Memorandum
- Traffic Noise Study Report
- Typical Section Package
- Utility Assessment Technical Memorandum
- Water Quality Impact Evaluation Checklist

3.0 – Project Design Controls and Criteria

Design controls include roadway functional classification, context classification, and design speed. These three elements establish the geometric and operational characteristics and criteria of the roadway. **Table 1** lists out the classifications and design speed as determined by the consultant using all available data and documentation.

Table 1: Design Controls and Criteria

Design Element	Design Standard	Source
General Criteria		
Design Standard Manual	2023 CFX Design Guidelines 2023 FDOT Design Manual (FDM)	
Design Vehicle:	WB-62 FL	FDM Section 201.6
Context Based Design	Interstate Criteria	CFX 200.1
Design Speed		FDM Table 201.5.1
Mainline	60 mph	
Ramps		FDM Table 201.5.2
• Loop and Semi-Direct	30 mph	
• Intermediate Portions of Long Ramps	40 mph	
• Direct Connections	50 mph	
Horizontal Geometry Criteria		
Lane Width		
Mainline	12 feet (mainline)	FDM Section 211.2
Ramps		
• One-lane	15 feet	FDM Section 211.2.1
• Two-lane	24 feet	FDM Section 211.2.1
Shoulder Width		
Mainline		
• Three-lane or more	12 feet inside and outside	FDM Table 211.4.1
Ramps		
• One-lane	6 feet inside and outside	FDM Table 211.4.1
• Two-lane	8 feet inside/12 feet outside	FDM Table 211.4.1
Median Width	26 feet (with barrier)	FDM Table 211.3.1
Border Width	10 feet (minimum for maintenance in conjunction with roadside barriers)	FDM Section 211.6.1
Lateral Offset	Light Poles <ul style="list-style-type: none"> Conventional: 20 feet from Travel Lane, 14 feet from Auxiliary Lane, or Clear Zone width, whichever is less High Mast: Outside Clear Zone 	FDM Table 215.2.2

Design Element	Design Standard	Source
	<p>Signal Poles and Controller Cabinets</p> <ul style="list-style-type: none"> • Outside Clear Zone <p>ITS Poles and Related Items</p> <ul style="list-style-type: none"> • Pole & Other Aboveground Fixed Object: Outside Clear Zone • Equipment Shelters and Towers: Outside limited access right of way. • Breakaway Objects: As Close to R/W As Possible <p>Traffic Control Signs</p> <ul style="list-style-type: none"> • Overhead Sign Structures: Outside Clear Zone <p>Trees</p> <ul style="list-style-type: none"> • Outside Clear Zone <p>Aboveground Utilities</p> <ul style="list-style-type: none"> • Existing Utilities: Outside Clear Zone • New or Relocated Utilities: Outside Clear Zone <p>Canal and Drop-off Hazards</p> <ul style="list-style-type: none"> • Not less than 60 feet for flush shoulder and curbed roadways with design speeds of 50 mph or greater. <p>Bridge Piers and Abutments</p> <ul style="list-style-type: none"> • Outside Clear Zone <p>Rigid Barrier Minimum Setback Distance</p> <ul style="list-style-type: none"> • Concrete Barrier $\geq 40''$ Height: 0 feet, 0 inches • Bridge Traffic Railing: 5 feet, 0 inches 	<p>FDM 220.3.2.3</p> <p>FDM 215.3.2</p> <p>FDM Table 215.2.2</p> <p>FDM Table 215.4.2</p>
Clear Zone Width	<p>Design Speed ≥ 60 mph</p> <ul style="list-style-type: none"> • 36 feet (travel lanes and multilane ramps) • 24 feet (auxiliary lanes and single lane ramps) <p>Design Speed = 55 mph</p> <ul style="list-style-type: none"> • 30 feet (travel lanes and multilane ramps) • 18 feet (auxiliary lanes and single lane ramps) 	<p>FDM Table 215.2.1</p>

Design Element	Design Standard	Source
	Design Speed = 45-50 mph <ul style="list-style-type: none"> • 24 feet (travel lanes and multilane ramps) • 14 feet (auxiliary lanes and single lane ramps) Design Speed = 40 mph <ul style="list-style-type: none"> • 18 feet (travel lanes and multilane ramps) • 10 feet (auxiliary lanes and single lane ramps) Design Speed = 35 mph <ul style="list-style-type: none"> • 14 feet (travel lanes and multilane ramps) • 10 feet (auxiliary lanes and single lane ramps) 	
Rate of Superelevation	0.10 (maximum)	FDM Section 210.9
Minimum Curve Radius	Mainline (60 mph) 1,146 feet	FDM Table 210.9.1
Length of Horizontal Curve	Mainline (60 mph) <ul style="list-style-type: none"> • 1,800 feet (desirable) • 900 feet (minimum) Ramp (50 mph) <ul style="list-style-type: none"> • 1,500 feet (desirable) • 750 feet (minimum) Ramp (≤ 45 mph) <ul style="list-style-type: none"> • 400 feet (minimum) 	FDM Table 211.7.1
Maximum Deflection without Curve	2° 00' 00" (≤ 40 mph) 0° 45' 00" (≥ 45 mph)	FDM Section 211.7.1
Maximum Deflection through Intersection	16° 00' (≤ 20 mph) 11° 00' (25 mph) 8° 00' (30 mph)	FDM Table 212.7.1
Maximum Deflection through Intersection	6° 00' (35 mph) 5° 00' (40 mph) 3° 00' (45 mph)	FDM Table 212.7.1
Auxiliary Lane Minimum Acceleration Length	370 feet	Policy on Geometric Design (AASHTO, Table 10-4)
Auxiliary Lane Drop	500 – 2,500 feet	Policy on Geometric Design (AASHTO, Figure 10-52)
Vertical Geometry Criteria		
Stopping Sight Distance Interstate	673 feet (65 mph, 3% Down) 613 feet (65 mph, 3% up)	FDM Table 211.10.1 FDM Table 211.10.1
Expressway/ Ramps	464 feet (50 mph, 5% Down) 393 feet (50 mph, 5% Up)	FDM Table 211.10.2 FDM Table 211.10.2

Design Element	Design Standard	Source
Maximum Profile Grade Limited Access Facilities Ramps	3% (60 mph) 5% (50 mph)	FDM Table 211.9.1 FDM Table 211.9.1
Minimum Length of Vertical Curve	Sag = 800 feet Crest (open highway) = 1,000 feet Crest (within interchanges) = 1,800 feet	FDM Table 211.9.3
Crest Vertical Curve (K- Value) Interstate (60 mph) Ramps (50 mph)	313 (new construction) 193 (resurfacing) 136 (new construction) 84 (resurfacing)	FDM Table 211.9.2
Sag Vertical Curve (K- Value) Interstate (60 mph) Ramps (50 mph)	157 96	FDM Table 211.9.2
Maximum Change in Grade without Vertical Curve	0.30 (60 mph) 0.60 (50 mph)	FDM Table 210.10.2
Vertical Clearance Existing Roadway Bridges New Overhead Sign Structures Existing Overhead Sign Structures New Dynamic Message Sign (DMS) Existing DMS New Signals Existing Signals	16.0 feet 17.5 feet 17.0 feet 19.5 feet 19.0 feet 17.5 feet 17.0 feet	FDM Table 260.6.1 FDM Section 210.10.3
Base Clearance	3 feet minimum from bottom of roadway base course to water elevation. A reduction for Ramps and certain Classification types is outlined in the requirements.	FDM Section 210.10.3

4.0 – Existing Conditions

The westbound lanes of SR 408 from I-4 to Bumby Avenue and Semoran Boulevard to Goldenrod Road currently provide four, 12-foot wide travel lanes in each direction within 180 to 300 feet of right of way. An auxiliary lane is also provided from the Rosalind Avenue exit to the entrance ramp from Bumby Avenue.

Other features of the project corridor include the following:

- 10-foot wide median landscaping located between the westbound and eastbound mainline barrier walls from east of the bridge over Rosalind Avenue to west of Bumby Avenue.
- Ramp toll gantries at the Bumby Avenue on-ramp and Semoran Boulevard off-ramp
- Noise walls
- Terraced landscaping at the overpass bridges

Below is a summary of existing conditions. Additional information is provided in the **Existing Conditions Memorandum** provided under separate cover.

Roadway

Existing Roadway Network

The existing roadway network under evaluation is SR 408 and the roadways that provide access to this portion of the limited access facility. Additional details about the roadways in the project area are provided below:

- SR 408 is a six- to ten-lane divided, east-west route that connects Ocoee from Florida's Turnpike in west Orange County to SR 50 (Colonial Drive) east of Alafaya Trail near the University of Central Florida in east Orange County.
- SR 408 provides access to both eastbound and westbound I-4, the major east-west interstate in Central Florida.
- The Rosalind Avenue exit ramp provides access to South Street and Rosalind Avenue. South Street is a three lane roadway serving westbound traffic only. Rosalind Avenue is a three lane roadway serving northbound traffic only. Both roadways provide access to the Downtown Orlando central business district.
- The Mills Avenue exit ramp provides access to South Street and Mills Avenue. South Street is a three lane roadway serving westbound traffic only. Mills Avenue is a north-south roadway that varies from two to four lanes and provides access to the Thornton Park neighborhood to the north and Lake Davis neighborhood to the south.
- Bumby Avenue, located on the outskirts of downtown, is a five lane roadway north of SR 408 and a two lane roadway south of SR 408. Bumby Avenue is a north-south roadway that provides access to the Milk District to the north and the Lake Como neighborhood to the south. Access to westbound SR 408 from Bumby Avenue is provided through South Street.
- Semoran Boulevard (SR 436) is a six lane divided, north-south roadway that provides access to residential areas east of downtown Orlando and Orlando International Airport.
- Goldenrod Road (SR 551) is a four lane roadway that connects Curry Ford Road to SR 50 and provides access to suburban areas east of downtown.

Design and Posted Speeds

Table 2 provides the design speed for the two study segments of SR 408.

Table 2: Posted and Design Speed

Roadway Name	Design Speed [mph]	Posted Speed [mph]
SR 408, from I-4 to Bumby Avenue	Horiz: 65 Vert: 55	60
SR 408, from Semoran Boulevard to Goldenrod Road	60	60

Typical Section

SR 408 roadway and roadside features were determined using the project 253A, C, and D as-built plans and aerial imagery. Table 3 provides information on the typical section for each segment.

Table 3: Typical Section

Segment	Travel Lanes	Outside Shoulder	Inside Shoulder	Right of Way
SR 408, from I-4 to Bumby Avenue	4 lanes, 12' wide	6' - 12'	10'	180' – 299'
SR 408, from Semoran Boulevard to Goldenrod Road	4 lanes, 12' wide	8'	10'	300'

Ramps

The following ramps are located within the SR 408 segments planned for widening:

I-4 to Bumby Avenue Segment

- I-4 Off-Ramp
- Rosalind Avenue Off-Ramp
- Mills Avenue Off-Ramp
- Bumby Avenue On-Ramp

Semoran Boulevard to Goldenrod Road Segment

- Semoran Boulevard On-Ramp
- Semoran Boulevard Off-Ramp
- Goldenrod Road On-Ramp

Additional information about these ramps is provided in Table 4.

Table 4: Ramp Data

Ramp Name	Ramp Type	Length of Acceleration/Deceleration [ft]
<i>SR 408, from I-4 to Bumby Avenue</i>		
I-4 Off Ramp`	Lane Drop	-
Rosalind Avenue Off-Ramp	Parallel	3,000
Mills Avenue Off-Ramp	Parallel	300
Bumby Avenue On-Ramp	Parallel	3,000
<i>SR 408, from Semoran Boulevard to Goldenrod Road</i>		
Semoran Boulevard Northbound On-Ramp	Parallel	2,650
Semoran Boulevard Off-Ramp	Parallel	750
Goldenrod Road On-Ramp	Parallel	1,550

Pavement Condition

The pavement condition of SR 408 in the project study area was determined using the Florida Department of Transportation’s Pavement Conditions Report, extracted on October 4, 2022. This report provides a numerical representation for both cracking and ride for each roadway segment (from a scale of 0 to 10, with 10 being the best). The findings, summarized in **Table 5** below, indicates the pavement condition is very good.

Table 5: Pavement Condition

Roadway Name	Pavement Type	Cracking	Ride
SR 408, from I-4 to Bumby Avenue	Asphalt	10.0	8.8
SR 408, from Semoran Boulevard to Goldenrod Road	Asphalt	10.0	8.6

Horizontal Alignment

Horizontal alignment data – including curves and their properties – is provided in the as-built plans for project 253 A, C, and D. Information about the curves on the study segments is provided in **Table 6**.

Table 6: Horizontal Alignment

Roadway Name	Number of Curves	Curve Radius [ft]	Curve Length [ft]	Description
SR 408, from I-4 to Bumby Avenue	3	2864.79	982.14	Super Elevated, e=0.062
		3819.72	939.48	Super Elevated, e=0.048
		3819.72	932.51	Super Elevated, e=0.048
SR 408, from Goldenrod Road to Semoran Boulevard	1	5721.63	3012.27	Super Elevated, e=0.032

The available horizontal stopping sight distance within the project segments was reviewed and no horizontal obstructions to sight distance were identified.

Vertical Alignment

Vertical alignment data, including curves and their properties, was obtained from the as-built plans for projects 253A, C, and D. Information about the curves on the study segments is provided in **Table 7**. No vertical obstructions to sight distance were identified in the study area.

Table 7: Vertical Alignment

Roadway Name	Flat or Rolling?	Number of Curves	Max Grade (%)	Number of Bridges
SR 408, from I-4 to Bumby Avenue	Rolling	8	3.12	4
SR 408, from Goldenrod Road to Semoran Boulevard	Rolling	4	2.98	5

Traffic Volumes

Traffic count data for roadways in the study area was obtained from the Florida Traffic Online (FTO) database. A summary of the data is provided in **Table 8**.

Table 8: Traffic Volume Data

Roadway Name	Site #	AADT	K-Factor	T- Factor
SR 408, from I-4 to Bumby Avenue	584	76,500	8.00	3.20
Rosalind Avenue Off Ramp	2176	9,300	8.00	6.20
Mills Avenue Off Ramp	2156	5,000	8.00	6.20
Bumby Avenue On Ramp	2158	8,200	8.00	6.20
I-4 Off Ramp	2167	13,000	8.00	6.20
SR 408, from Semoran Boulevard to Goldenrod Road	585	69,500	9.00	3.20
Semoran Boulevard Northbound On Ramp	2170	6,200	8.00	6.20
Semoran Boulevard Southbound On Ramp	2163	6,500	8.00	6.20
Semoran Boulevard Off Ramp	2180	5,600	8.00	6.20
Goldenrod Road On Ramp	2165	6,300	8.00	6.20

Crash Data

Crash data was obtained for the study segments from the Signal4 Analytics database. Data was obtained for the most recent, complete six years of data, from January 1, 2016 to December 31, 2021. Crash data is summarized in **Tables 9 - 12**.

The crash data was evaluated based on frequency, severity, type of impact, roadway conditions, and environmental conditions.

Table 9: Crash Frequency

Roadway Name	Total Number of Crashes	Year					
		2016	2017	2018	2019	2020	2021
SR 408, from I-4 to Bumby Avenue	545	90	80	77	125	92	81
SR 408, from Semoran Boulevard to Goldenrod Road	200	38	22	52	44	18	26

Table 10: Crash Severity

Roadway Name	Total Number of Crashes	Severity		
		PDO	Injury	Fatal
SR 408, from I-4 to Bumby Avenue	545	370	174	1
SR 408, from Semoran Boulevard to Goldenrod Road	200	143	57	0

Table 11: Crash Type

Roadway Name	Total Number of Crashes	Type of Impact				
		Angle	Head On	Rear End	Sideswipe	Other
SR 408, from I-4 to Bumby Avenue	545	58	3	343	84	57
SR 408, from Semoran Boulevard to Goldenrod Road	200	25	3	100	36	36

Table 12: Crash Conditions

Roadway Name	Total Number of Crashes	Lighting			Road Surface		Weather		
		Day	Night	Lighted	Dry	Wet	Clear	Cloudy	Rain
SR 408, from I-4 to Bumby Avenue	545	469	17	59	460	85	405	78	62
SR 408, from Semoran Boulevard to Goldenrod Road	200	154	10	36	167	33	151	35	14

545 crashes were reported in the westbound direction on the 1.4-mile segment of SR 408 from I-4 to Bumby Avenue from the start of 2016 to the end of 2021. For this same time period, 200 crashes were reported in the westbound direction on the 1.5-mile segment of SR 408 from Semoran Boulevard to Goldenrod Road. One fatality was reported on this segment at the Bumby Avenue on-ramp and involved a pedestrian. Approximately 30% of the crashes along the study segments of SR 408 resulted in an injury. Most common impact type on both segments is rear end. With the proposed widening, operations are anticipated to improve which should reduce the number of collisions.

Structures

There are ten existing bridges within the project limits carrying westbound traffic with potential to be impacted:

- Bridge No. 750570 – SR 408 WB to I-4 EB Ramp D
- Bridge No. 750571 – SR 408 WB to I-4 EB Ramp D-1
- Bridge No. 750242 – SR 408 WB over Summerlin Avenue
- Bridge No. 750116 – SR 408 WB over Mills Avenue
- Bridge No. 750244 – SR 408 over Bumby Avenue
- Bridge No. 750581 – SR 408 over SR 436 (Semoran Boulevard)
- Bridge No. 750126 – SR 408 WB over Yucatan Drive
- Bridge No. 750251 – SR 408 WB over Oxalis Drive
- Bridge No. 750128 – SR 408 WB over Cosmos Drive
- Bridge No. 750129 – SR 408 WB over SR 551 (Goldenrod Road)

Bridge information pertinent to the study was compiled from National Bridge Inventory Data and field verified. A description of each bridge is provided below:

SR 408 WB to I-4 EB Ramp D (Bridge No. 750570)

The existing bridge was constructed in 2008 and consists of ten spans comprised of either prestressed concrete box girders or steel continuous box girders and both have a concrete deck superstructure. The maximum span length is 220.0 feet and the total bridge length is 1,911.0 feet. The minimum vertical clearance is 26.7 feet. The existing bridge provides two travel lanes and shoulders on each side. The total width of the deck from edge to edge is 45.0 feet. The inspection report dated June 2020 states that the bridge has a sufficiency rating of 97.3. The inspection report also indicated the superstructure and substructure have an overall rating of Very Good (8 out of 9) and the deck has an overall rating of Good (7 out of 9).

SR 408 WB to I-4 EB Ramp D-1 (Bridge No. 750571)

The existing bridge was constructed in 2008 and consists of seven spans comprised of steel continuous box girders and concrete deck superstructure. The maximum span length is 230.0 feet and the total bridge length is 1,447.0 feet. The minimum vertical clearance is 16.1 feet. The existing bridge provides one travel lane and shoulders on each side. The total width of the deck from edge to edge is 36.6 feet. The inspection report dated June 2020 states that the bridge has a sufficiency rating of 97.3. The inspection report also indicated the superstructure and substructure have an overall rating of Very Good (8 out of 9) and the deck has an overall rating of Good (7 out of 9).

SR 408 over Summerlin Avenue (Bridge No. 750242)

The existing bridge was constructed in 1973 and consists of three spans with prestressed concrete girders and a concrete deck superstructure. The maximum span length is 94.0 feet and the total bridge length is 166.0 feet. The vertical clearance over Summerlin Avenue is 16.2 feet. The existing bridge provides three travel lanes, one auxiliary lane, and shoulders on each side for westbound traffic and five travel lanes, one auxiliary lane, and shoulders on each side for eastbound traffic. The total width of the deck from edge to edge is 174.3 feet. The inspection report dated April 2021 states that the bridge has a sufficiency rating of 67.0. The inspection report also indicated the deck, superstructure, and substructure have an overall rating of Good (7 out of 9).

SR 408 WB over Mills Avenue (Bridge No. 750116)

The existing bridge was constructed in 1973 and consists of four spans with prestressed concrete girders and a concrete deck superstructure. The maximum span length is 59.2 feet and the total bridge length is 203.4 feet. The vertical clearance over Mills Avenue is 16.4 feet. The existing bridge provides five travel lanes with shoulders on each side. The total width of the deck from edge to edge is 95.1 feet. The inspection report dated October 2021 states that the bridge has a sufficiency rating of 92.3. The inspection report also indicated that the deck, superstructure, and substructure have an overall rating of Good (7 out of 9).

SR 408 over Bumby Avenue (Bridge No. 750244)

The existing bridge was constructed in 1973 and consists of four spans with prestressed concrete girders and a concrete deck superstructure. The maximum span length is 59.0 feet and the total bridge length is 191.5 feet. The vertical clearance over Bumby Avenue is 16.3 feet. The existing bridge provides four travel lanes and shoulders on each side for westbound traffic and five travel lanes and shoulders on each side for eastbound traffic. The total width of the deck from edge to edge is 173.0 feet. The inspection report dated April 2021 states that the bridge has a sufficiency rating of 81.1. The inspection report also indicated the deck, superstructure, and substructure have an overall rating of Good (7 out of 9).

SR 408 over SR 436 (Semoran Boulevard) (Bridge No. 750581)

The existing bridge was constructed in 2007 and consists of a single span of steel plate girders and concrete deck superstructure. The maximum span length is 157.0 feet and the total bridge length is 159.0 feet. The minimum vertical clearance is 20.2 feet. The existing bridge provides eight travel lanes, two auxiliary lanes, and shoulders on each side. The total width of the deck from edge to edge is 177.0 feet. The inspection report dated March 2021 states that the bridge has a sufficiency rating of 100.0. The inspection report also indicated the superstructure, substructure, and deck have an overall rating of Very Good (8 out of 9).

SR 408 WB over Yucatan Drive (Bridge No. 750126)

The existing bridge was constructed in 1973 and consists of three spans with prestressed concrete girders and a concrete deck superstructure. The maximum span length is 61.0 feet and the total bridge length is 127.7 feet. The vertical clearance over Yucatan Drive is 16.4 feet. The existing bridge provides four travel lanes, one auxiliary lane, and shoulders on each side. The total width of the deck from edge to edge is 83.0 feet. The inspection report dated April 2021 states that the bridge has a sufficiency rating of 95.9. The inspection report also indicated that the deck, superstructure, and substructure have an overall rating of Good (7 out of 9).

SR 408 WB over Oxalis Drive (Bridge No. 750251)

The existing bridge was constructed in 1973 and consists of three spans with prestressed concrete girders and a concrete deck superstructure. The maximum span length is 57.4 feet and the total bridge length is 126.0 feet. The vertical clearance over Oxalis Drive is 15.4 feet. The existing bridge provides four travel lanes and shoulders on each side. The total width of the deck from edge to edge is 70.5 feet. The inspection report dated April 2021 states that the bridge has a sufficiency rating of 92.3. The inspection report also indicated the deck, superstructure, and substructure have an overall rating of Good (7 out of 9).

SR 408 WB over Cosmos Drive (Bridge No. 750128)

The existing bridge was constructed in 1973 and consists of three spans with prestressed concrete girders and a concrete deck superstructure. The maximum span length is 57.4 feet and the total bridge length is 130.9 feet. The vertical clearance over Cosmos Drive is 15.0 feet. The existing bridge provides four travel lanes, two auxiliary lanes, and shoulders on each side.

The total width of the deck from edge to edge is 94.2 feet. The inspection report dated February 2022 states that the bridge has a sufficiency rating of 94.7. The inspection report also indicated that the deck, superstructure, and substructure have an overall rating of Good (7 out of 9).

SR 408 WB over SR 551 (Goldenrod Road) (Bridge No. 750129)

The functionally obsolete existing bridge was constructed in 1973 and consists of four spans with prestressed concrete girders and a concrete deck superstructure. The maximum span length is 63.0 feet and the total bridge length is 201.0 feet. The vertical clearance over Goldenrod Road is 15.9 feet. The existing bridge provides four travel lanes, one auxiliary lane, and shoulders on each side. The total width of the deck from edge to edge is 84.7 feet. The inspection report dated May 2022 states that the bridge has a sufficiency rating of 90.6. The inspection report also indicated superstructure, and substructure have an overall rating of Good (7 out of 9) while the deck has an overall rating of Satisfactory (6 out of 9).

Drainage

Hydrology

The study area, shown in **Figure 2**, consists of both open and closed basins. Between I-4 and west of the Lake Underhill Toll Plaza, runoff from SR 408 is routed to several lakes: Lake Cherokee, Lake Greenwood, Lake Como, and Lake Underhill. The project is within the Lake Underhill Outfall basin (WBID 3168ZA) and is part of the Upper Kissimmee River Watershed that ultimately discharges south to Lake Okeechobee. Historically, these lakes are considered to be landlocked by St Johns River Water Management District (SJRWMD). The lake outfalls consist of either a drainwell that discharges into the groundwater and/or an overflow structure to cascade south to a downstream lake that is controlled by a pump station. SR 408 existing drainage between the Lake Underhill Toll Plaza and the Goldenrod Road interchange drains north to either a conveyance ditch to Lake Barton within the Lake Baldwin Outfall basin (WBID 3023A) or to the Yucatan Outfall Canal within the Azalea Park Canal basin (WBID 3025); both of which flow northeast to Crane Strand basin (WBID 3023) which flow east to discharge to the Little Econlockhatchee River basin (WBID 3001) which ultimately flows north towards the St. Johns River. The Yucatan Outfall Canal also functions as the northern outfall for Lake Underhill. Ambient Water Quality is summarized in **Table 13**.

The project is located within the jurisdiction of the SJRWMD. Lake Como within Orange County is listed as an impaired waterbody for total phosphorus. The study area is also within the Econlockhatchee River Hydrologic basin but does not contain any portions of the Econlockhatchee River Riparian Habitat Protection Zone. The Econlockhatchee River Hydrologic Basin has additional requirements to meet SJRWMD criteria related to peak discharge rates for both the mean annual and 25-year storm events, as well as providing floodplain compensation for any locations with upstream drainage area of one square mile or more.

Figure 2: Drainage Basins Overview Map

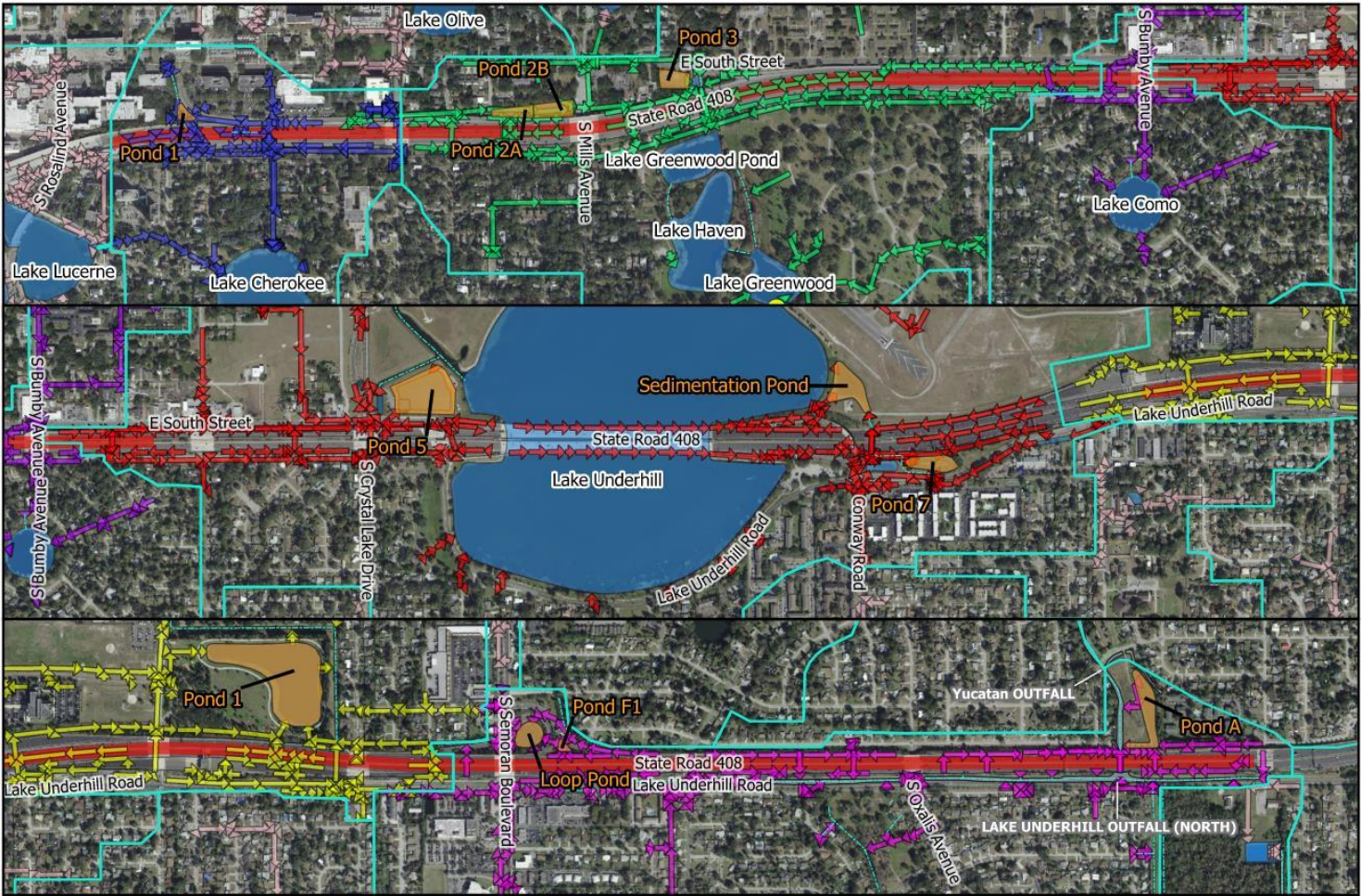

Legend

- Ponds & Lakes
- Pump Stations
- Secondary Canals Water
- Storm Sewer Systems by Basin
- Lake Como Basin
- Yucatan Outfall Canal
- FEMA FIRM
- Project Limits
- Drainwells
- Existing SR 408 Ponds
- Lake Cherokee Basin
- Lake Underhill Basin
- ELSE
- FEMA Zone AE
- FEMA Zone A
- Lake Greenwood Basin
- Lake Barton Basin
- FEMA Floodway

Table 13: Ambient Water Quality

Basin	WBID	Outfall	BMAP	TMD L	Waters Not Attaining Standards	
					Verified Impaired ⁽¹⁾	Study List ⁽²⁾
Lake Cherokee	3168X6	Lake Underhill Outlet (WBID 3168Z)	Lake Okeechobee	--	--	--
Lake Greenwood	3168Y3			--	--	--
Lake Como (Orange Co.)	3168Y2			--	TP	--
Lake Underhill	3168G			--	--	--
Lake Underhill Outlet	3168ZA			--	--	DO
Lake Baldwin Outfall	3023A	Little Econlockhatchee River ⁽³⁾ (WBID 3001)	--	Fecal	Fecal	--
Azalea Park Canal	3025				--	--

Water Quality Parameters:
DO – Dissolved Oxygen, TP – Total Phosphorus, Fecal – Fecal Coliform

Notes:
(1) Impaired waterbodies per FDEP Comprehensive Verified List (September 2022)
(2) Other waters not attaining standards per FDEP Comprehensive Study List (September 2022)
(3) Little Econlockhatchee River is an Outstanding Florida Waterbody (OFW).

Previous SR 408 plans and existing SJRWMD permits for the project corridor were researched to obtain stormwater and drainage design information. Applicable SR 408 design contracts are listed, and permits are summarized in **Table 14**.

- 408-253A: East of I-4 interchange to Crystal Lake Drive,
- 408-253B: Crystal Lake Drive to Conway Road,
- 408-253C: Conway Road to Oxalis Avenue, and
- 408-253D: Oxalis Avenue to Chickasaw Trail

Under these contracts, SR 408 was widened from a 6-lane to an 8-lane condition, with the exception of contract 408-253B where a 10-lane section was constructed. The SMFs for these projects are permitted to treat and attenuate for the ultimate 10-lane condition. The SMF design utilizes compensatory treatment and basin diversion to attenuate at the outfalls to accommodate these improvements. This was accomplished by routing an equivalent area of impervious area along the mainline and ramps to each SMF to match the net new impervious area for each outlet and, where necessary, shift basin lines along SR 408 to an SMF or adjacent watershed in lieu of an existing outfall. The SMFs continue to discharge into the stormwater conveyance systems that are conveyed to the historical outfall within each basin. A majority of the existing SR 408 SMFs are located on the north side of the SR 408 mainline, which may be impacted by the proposed westbound widening. Refer to **Table 15** for a Summary of the Existing Treatment Facilities.

Between I-4 and the Lake Underhill Toll Plaza, located within the Lake Underhill Outlet Watershed, the SMFs are designed for landlocked outfalls (closed basins) where pre-post attenuation volume calculated from the Soil Conservation Service (SCS) runoff curve number method was established utilizing the 25-year/96-hour storm event; SMFs were still allowed to discharge. From the Lake Underhill Toll Plaza to Goldenrod Road, located within the Little Econlockhatchee watershed, the project has positive outfall (open basins). These SMFs were designed for the 25-year/24-hour storm event and meet the additional criteria for the Little Econlockhatchee Hydrologic Basin.

Table 14: Permit Summary

Project Name	Permit No.	Date Issued	Description
SR 408 Improvements – Rosalind Ave to Crystal Lake Dr, Contract 253A	SJRWMD 92150-1	4/23/2004	Widen SR 408 from 6-lane to 8-lane. Stormwater management facilities (SMFs) designed for ultimate 10-lane (widening to median) and provides compensatory treatment and attenuation. Outfall lakes within Lake Underhill Outlet watershed considered landlocked lakes. Decreased SR 408 basin area to Lake Como in lieu of building an SMF.
SR 408 Improvements – Pond 5 Relocation	SJRWMD 92150-2	8/27/2004	Relocated Pond 5 closer to Lake Underhill, Joint-Use of SMF between CFX (Project 253A and 253B) and the City of Orlando for Crystal Lake Drive Improvements.
SR 408 WB Off-Ramp Improvements at Mills Ave. (CFX 408-159)	SJRWMD 92150-6	12/20/2019	Off-ramp widening project, Modification to SMF Pond 3 by lowering pond bottom 0.5-feet. Nutrient analysis included.
SR 408 from Crystal Lake Drive to Conway Rd, Contract 253B	SJRWMD 96799-1	9/13/2005	SR 408 Bridge over Lake Underhill expanded to 10-lane condition. The 10-lane condition is already built.
SR 408 Widening from Conway Rd to Oxalis Ave, Contract 253C	SJRWMD 96799-2	12/13/2005	SR 408 Widening from 6-lane to 8-lane. SMFs designed for ultimate 10-lane. Project located within Econlockhatchee River Hydrologic Basin but does not contain portion of Econlockhatchee River Riparian Habitat Protection Zone
SR 408 Widening from Oxalis Ave to Chickasaw Trail, Contract 253D	SJRWMD 20358-18	1/29/2010	Widen SR 408 from 6-lane to 10-lanes. Mentions the large (2)-6'x7' CBC culvert within the Azalea Park Canal watershed includes a sharp-crested weir and vertical volume recovery structure (VRS) located on the north to meet Orange County's NPDES permit.

Table 15: Summary of Existing Treatment Facilities

Contract	Treatment Facility	Treatment Method	Treatment Criteria	Basin Area (ac)	Required Treatment (ac-ft)	Provided Treatment (ac-ft)	Discharge Location	Special Criteria	Comments
408-253A	Pond 1 ⁽¹⁾ (SR 408 Off-ramp to South St)	Online Dry Retention	1.25-inch over net new impervious area + 0.5-inch over basin for Online	2.87	0.36	0.44	Lake Cherokee	landlocked, permitted attenuation set for pre-post volume of the 25-yr/96-hr	Permitted under SJRWMD 92150-1 for Ult. 10-lane ⁽²⁾
	Pond 2A ⁽¹⁾ (SR 408 & Mills Ave)	Online Dry Retention		4.38	0.59	0.59	Lake Greenwood		
	Pond 2B ⁽¹⁾ (SR 408 & Mills Ave)	Online Dry Retention		4.19	0.53	0.55			
	Pond 3 ⁽³⁾ (SR 408 Off-ramp to South St)	Online Dry Retention		4.44	0.54	1.57			
	Pond 5	Online Dry Retention		17.75	2.19	4.87	Lake Underhill		Permitted under SJRWMD 92150-2 as Joint Use SMF (CFX & City of Orlando) for Ult. 10-lane ⁽²⁾
	Lake Greenwood	Expansion of existing lake	N/A, Attenuation only	33.01	--	--	Pump Station		Permitted under SJRWMD 92150-1 for Ult. 10-lane ⁽²⁾ , this artificial stormwater retention pond is exempt from water quality standards
408-253C	Pond 1	Wet Detention	Greater of: 1-inch over basin, 2.5-inch over impervious	104	10.29	13.94	Canal to Lake Barton	Little Econ Hydrologic Basin Criteria	--
	Loop Pond	Wet Detention		8.5	0.51	1.08	Lake Underhill Road roadside ditch to Yucatan Outfall Canal		--
	Pond F1 ⁽¹⁾	Dry Retention	N/A, Attenuation only	1.8	--	0.24			No treatment credit taken for the dry retention infield area
408-253D	Pond A	Wet Detention	Greater of: 1-inch over basin, 2.5-inch over impervious	24.24	2.28	2.28	Yucatan Outfall		
	(2)-6'x7' CBC ⁽⁴⁾	Wetlands & swales	--	--	--	--		NPDES	VRS south of SR 408 to treat 20% of required treatment volume for Lake Azalea Estates subdivision (SJRWMD Permit 4-095-20358-6)

Floodplains

The Federal Emergency Management Agency (FEMA) has determined the 100-year floodplain limits in the vicinity of the project limits in the form of Flood Insurance Rate Maps (FIRM). In **Figure 2**, the 100-year floodplain limits are presented from City of Orlando and Orange County Unincorporated Areas panels 12095C0245F, 12095C0265F, 12095C0270F effective 9/25/2009, with a Letter of Map Revision (LOMR) 14-04-4627P, effective 1/9/2015, located along the south side of Lake Underhill Road.

The 100-year floodplain crosses the SR 408 right of way in the location of either a bridge or cross drain that connects the floodplain on either side of the road. These locations include the bridge over Lake Lucerne near the I-4 interchange, the Fern Creek double 6-foot x 8-foot box culvert near Mills Avenue interchange, the bridge over Lake Underhill, and the Yucatan Outfall Canal double 6-foot x 7-foot box culvert. At the two bridge locations, Lake Lucerne has an established base flood elevation (BFE) of 87.7 feet NAVD88 and Lake Underhill has an established BFE of 101.4 feet NAVD88.

Fern Creek is a regulated floodway that flows from north to south through the SR 408 right of way, concluding at Lake Greenwood which is located south of and adjacent to the SR 408 right of way. From ERP data, Lake Greenwood is considered the lowest lying lake in the area. From review of the City of Orlando stormwater database (2015), Lake Greenwood has a single outfall, a pump station located at its southern most point. The BFE at the floodway entering SR 408 right of way is 74.9 feet NAVD88, with Lake Greenwood's BFE set to 74.6 feet NAVD88.

The Yucatan Outfall Canal flows from south to north to Orange County's Primary Canal system between Lake Barton to Little Econlockahatee River. The Yucatan Outfall Canal is designated as a FEMA Flood Zone A, which does not have an established BFE. The upstream basin for this cross drain includes an overflow conveyance ditch for Lake Underhill as documented within the County Stormwater database (2022) and a large wetland system (Ponding Area M9) located within the LOMR, which has an established BFE of 88.4 feet NAVD88. Within ERP 20358-18, it was noted that the (2)-6'x7' box culverts under SR 408 includes a vertical volume recovery structure along the upstream endwall, south of SR 408 to provide treatment for the Lake Azalea Estates subdivision (SJRWMD Permit 4-095-20358-6) for the Orange County NPDES permit.

Utilities

The utility agencies/owners (UAOs) in the study area were determined using a variety of sources. First, a Sunshine 811 Design Ticket was made to identify the utility providers and operators registered in the area. These utility providers were then contacted to establish the proper personnel to assist with locating and identifying existing and planned utilities in the area. Lastly, plans, permits and/or mapping of the utilities were requested for review including any right of way or easement agreements along the affected corridors. The UAO identities on the project are summarized in **Table 16**. Additional information is provided in the **Utility Assessment Technical Memorandum** available under separate cover.

Table 16: List of Utility Contact Information

Utility Owner	Contact	Email/Phone	Facilities
Windstream	TBD	locate.desk@windstream.com	Fiber
ATT	Marin	martin@trecgroup.com	Fiber
Black and Veatch	Chad Arnett	TBD	TBD
American Traffic Solutions	Victoris Grasser	(408) 596-4559	TBD
Centurylink	Bill McCloud	(850) 599-1444	Fiber, Telephone
City of Orlando – Water Reclamation	Michael Zeno	michael.zeno@cityoforlando.net	Water
Charter Communications	John Smith	john.smith5@charter.com	Fiber
Florida Gas Transportation	Joseph Sanchez	joseph.e.sanchez@energytransfer.com	Gas
Zayo Group	Henry Klobucar	(406) 496-6510	Fiber
Duke Energy	TBD	(407) 629-1010	Electric
MCI	TBD	investigations@verizon.com	Fiber
Crown Castle NG Fiber	TBD	fiber.dig@crowncastle.com	Fiber
Orange County – Waste Water	Marc Brown	marc.brown@ocfl.net	Sewer
Orange County – Water	Marc Brown	marc.brown@ocfl.net	Water
Orange County Public Works	Matthew Shipley	(407) 836-7814	TBD
City of Orlando - Fiber	John Falango	orlando_traffic_signal_construction@cityoforlando.net	Fiber
OUC – Fiber	Julie Leininger	(407) 434-4198	Fiber
OUC – Chilled Water	Ron Hawkins	(407) 434-2569	Water
OUC - Water	Steve Lockington	(407) 434-2568	Water
OUC – Electric	Juan Diaz	developmentservices@OUC.com	Electric
Summit Broadband	Michelle Daniel	(407) 996-1183	Fiber
TECO Peoples Gas	Joan Domning	(813) 275-3783	Gas
AT&T Distribution	Dino Farruggio	G27896@ATT.com	Fiber
EMBARQ Communication Inc.	Robert Godek	(407) 830-3421	Fiber
Uniti Fiber LLC	Charlie Croft	Charlie.croft@uniti.com	Fiber
Traffic Control Device	Patricia Vickers	(407) 869-5300 (option 168)	TBD
Sprint	Jon Baker	(352) 409-5095	TBD

Windstream

Windstream has an underground fiber line crossing under SR 408 along Boone Avenue and Lucerne Circle.

AT&T

AT&T was emailed on 4/14/2023 with no response.

Black and Veatch

Black and Veatch was emailed on 3/31/2023 and then again on 7/11/2023 with no response.

American Traffic Solutions

American Traffic Solutions has no facilities within the project limits.

Centurylink

Centurylink was emailed on 3/31/2023 and then again on 7/11/2023 with no response.

City of Orlando – Water Reclamation

The City of Orlando-Water Reclamation Division has the following facilities within the project limits:

- Private Unknown Sanitary Sewer running underneath SR 408 between Delaney Ave and Margaret Court
- 27" Sanitary Sewer running along SR 408
- 8" Sanitary Sewer running underneath SR 408 along Summerlin Avenue
- 30" Sanitary Sewer running underneath SR 408 along South Mills Avenue and along SR 408
- 24" Sanitary Force Main running underneath SR 408 between South Lawsona Boulevard and Reeves Court
- 24" Sanitary Sewer running along East South Street
- 15" Sanitary Sewer running along East South Street
- 10" Sanitary Sewer running underneath SR 408 along Hampton Avenue
- 12" Sanitary Sewer running along East South Street
- 30" Sanitary Force Main running along East South Street
- 12" Sanitary Sewer running underneath SR 408 along Wiltshire Road
- 8" Sanitary Sewer running underneath SR 408 along North Primrose Drive
- 8" Sanitary Sewer running underneath SR 408 between North Primrose Drive and South Lakewood Drive
- 8" Force Main running underneath SR 408 along South Crystal Lake Drive
- 8" Sanitary Sewer running underneath SR 408 along South Solandra Drive
- 8" Sanitary Sewer running underneath SR 408 along South Semoran Boulevard
- 10" Sanitary Sewer running underneath SR 408 along Yucatan Drive
- 8" Sanitary Sewer running underneath SR 408 along South Oxalis Drive

Charter Communications

Charter Communications has underground fiber line along Summerlin Avenue, Primrose Drive, Yucatan Drive, and Goldenrod Road. Along Summerlin Avenue, their service line is located on the west side of the road. Along Primrose Drive, the service line runs on the east side of the road. Along Yucatan Drive, their service line is located on the west side of the road. Along

Goldenrod Road, the service line runs on the east side of the road.

Florida Gas Transportation

Florida Gas Transmission was emailed on 4/14/2023 and then again on 7/11/2023 with no response.

Zayo Group

Zayo Group was called with voicemail on 3/31/2023 and then again on 7/11/2023 with no response.

Duke Energy (Distribution)

Duke Energy was called on 3/31/2023 and then again on 7/11/2023 with no response.

MCI

MCI required a form to be submitted and that form was submitted on 4/18/2023 with no response.

Crown Castle

Crown Castle has facilities located within the project limit. They have underground conduit that is running along South Street and turning towards the south along Crystal Lake Drive. Once it gets to Anderson Street it heads east along Lake Underhill Road and then north along Goldenrod Road.

Orange County

Orange County has a gravity sewer line running along the west side of Cosmos Drive and then along the south side of Lake Underhill Road. They also have a sewer line that is running along the east side of Capehart Drive running underneath SR 408. They have a water line running along the east side of Cosmos Drive heading to a tee on Lake Underhill Road and running east.

Orlando Utilities Commission (OUC)

OUC has an 8" DIP and 8" Universal Joint Cast-iron watermain along Lucerne Circle. They have 10" DIP watermain on the western side of Summerlin Avenue. They have 6" Mechanical Joint Cast-iron watermain on the western side of Mills Avenue. They have 8" Universal Joint Cast-iron watermain along the western side of Bumby Avenue. They have 16" Universal Joint Cast-iron watermain running on the southern side of South Street between Primrose Drive and Crystal Lake Drive and turns towards the south on Crystal Lake Drive. They have a 12" Universal Joint Cast-iron watermain on the eastern side of Semoran Boulevard. They have a 12" DIP and Universal Joint Cast-iron watermain on the western side of Oxalis Avenue.

Summit Broadband

Summit Broadband was emailed on 3/31/2023 and then again on 7/11/2023 with no response.

TECO Peoples Gas

TECO Peoples Gas was emailed on 3/31/2023 and then again on 7/11/2023 with no response.

AT&T Distribution

AT&T Distribution has an underground duct crossing SR 408 along Magnolia Avenue, Mills Avenue, Bumby Avenue, and S Crystal Lake Drive. They have duct running along East South

Street. They have a manhole near the intersection of E South Street and S Bumby Avenue, and manholes along East South Street between North Primrose Drive and South Crystal Lake Drive. They have aerial Copper running along East South Street, along East Anderson Street, and along Bamboo Drive. They have buried Copper line running underneath SR 408 along Summerlin Avenue, along North Primrose Drive, along Capehart Drive, and along South Alder Drive. They have buried Copper line along East South Street and along Lake Underhill Road. They have aerial Fiber running along Bamboo Drive. They have Cabinets located near the intersection of South Oxalia Drive and Bamboo Drive, near the intersection of South Alder Drive and Bamboo Drive, and one at the intersection of Cosmos Drive and Bamboo Drive. They have buried Fiber running underneath SR 408 along South Oxalia Drive, along Palmyra Drive, and along Bamboo Drive. They have a 4" HDPE running underneath SR 408 along Cosmos Drive.

Uniti Fiber LLC

Uniti Fiber LLC was emailed on 4/14/2023 with no response.

EMBARQ Communication INC

EMBARQ Communications was contacted on 4/4/2023 but both the primary and alternative phone numbers failed.

Sprint

Sprint was emailed on 4/14/2023 with no response.

Lighting

SR 408, from I-4 to Bumby Avenue

The segment of SR 408 from I-4 to Bumby Avenue has conventional light poles on both sides of the roadway. These poles appear to be spaced approximately 200 feet apart. There are LED luminaires on rounded cobra head arms that extend off the pole upright. The conventional light poles and luminaires are painted black. Along the bridge sections of SR 408, the poles are mounted to the bridge. Near the Rosalind Avenue exit, the poles are installed on the ground behind guardrail or mounted to the barrier wall. All poles are fed by underground or bridge mounted/embedded conduit.

SR 408, from Semoran Boulevard to Goldenrod Road

There are conventional light poles along SR 408 from Semoran Boulevard to Goldenrod Road spaced approximately 150-200 feet apart. These light poles have LED luminaires on cobra head arms that extend off the pole upright. Some poles are ground mounted, while others are mounted to the bridge sections of the roadway. There are no light poles in the median, and all poles and fixtures are painted black. Light pole power sources appear to be underground or routed through bridge mounted/embedded conduit.



Intelligent Transportation Systems

SR 408, from I-4 to Bumby Avenue

The ITS configuration along SR 408 includes two (2) 72-count single mode backbone Fiber Optic Cables (FOC) buried along both sides of the mainline expressway, under the eastbound shoulder and the westbound shoulders, for the entire limits of the analysis area. They do not extend along the ramps to Interstate-4.

Within the analysis area, there are multiple closed-circuit television (CCTV) cameras, microwave vehicle detection systems (MVDS), automatic vehicle identification (AVI), dynamic message signs (DMS), and wrong way detection systems (WWDS). These devices are summarized in **Table 17** below based on mile marker location:

Table 17: Existing ITS Inventory - I-4 to Bumby Avenue

<p>AVI-408- I4-WB and MVDS- 408- 10.6-WB</p>	
<p>WWDS- 408- Exit11A- WB</p>	



TMS-
408-
Exit11A-
WB

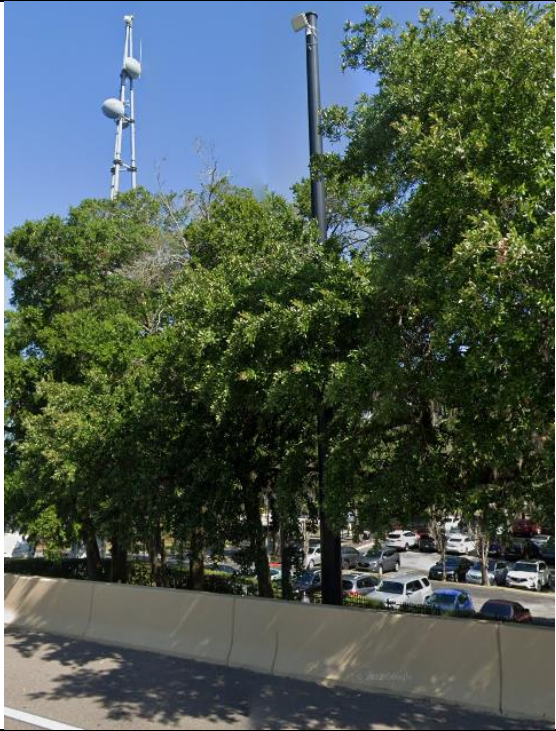

AVI-408-
10.9-WB
and
TMS-
408-
10.9-WB



DMS-
408-
11.2-WB



WWDS-
408-
Exit11B-
WB





CCTV-408-11.3-WB, AVI-408-11.3-WB, and MVDS-408-11.3-WB



MVDS-
408-
11.6-WB



DMS-
408-
11.7-WB



CCTV-
408-
11.8-WB



SR 408, from Semoran Boulevard to Goldenrod Road

The ITS configuration along SR 408 includes two (2) 72-count single mode backbone Fiber Optic Cables (FOC) buried along both sides of the mainline expressway, under the eastbound shoulder and the westbound shoulders, for the entire limits of the analysis area.

Within the analysis area, there are multiple closed-circuit television (CCTV) cameras, microwave vehicle detection systems (MVDS), automatic vehicle identification (AVI), dynamic message signs (DMS), and wrong way detection systems (WWDS). These devices are summarized in **Table 18** below based on mile marker location:

Table 18: Existing ITS Inventory - Semoran Boulevard to Goldenrod Road

WWDS-408-Exit14-WB	
--------------------	---

CCTV-408-14.4-WB, MVDS-408-14.4A-WB, and MVDS-408-14.4B-WB



AVI-408-14.5-WB, MVDS-408-14.5-WB, and MVDS-408-14.5-EB





DMS-
408-
15.2-WB



CCTV-
408-
15.4-WB



MVDS-
408-
15.9-WB



Geotechnical

Based on review of available documents, the USGS Quadrangle Map, the NRCS Orange County Soil Survey and current plans, the following observations are noted.

- Natural ground surface topography varies from +75 to +110 feet NGVD from I-4 to Bumby Avenue and from +90 to +100 feet NGVD from Semoran Boulevard to Goldenrod Road.
- Land use in both project areas is primarily residential and light commercial.
- Near surface soils for both segments are primarily poorly drained sandy soils. The segment from Semoran Boulevard to Goldenrod Road contains organic muck soils (soil type 41).
- The muck soils were likely removed for the original SR 408 construction.
- Groundwater depth varies based on topography but is generally within 5 feet of natural grade.
- Review of available plans indicate the bridges were originally supported on 18-inch precast piles extending 50 to 100 feet below natural grade.
- Piles for the inside widening that was performed about 15 years ago utilized steel HP piles, extending 80 to 120 feet below natural grade.
- Geotechnical considerations include exploration for highly compressible organic muck soils, evaluation of variable groundwater conditions and deep Standard Penetration Test (SPT) borings for bridge foundation design.
- Bridges should be supported on a deep driven pile substructure due to Karst environment and likely high Factored Loads required.
- Dry stormwater ponds may be feasible depending on pond location, the presence of the clay confining layer and groundwater levels.

5.0 – Traffic Analysis

A traffic analysis was conducted and is documented under a **Project Traffic Analysis Memorandum** available under separate cover. The traffic analysis provides future traffic forecasts and operational analysis for the 2025 opening year and 2045 design year.

By the year 2045, the Annual Average Daily Traffic (AADT) is expected to reach as high as 233,400 from I-4 to Bumby Avenue. From Semoran Boulevard to Goldenrod Road, the AADT is expected to reach 185,600.

The traffic analysis evaluated multiple options including the following:

- Alternative 202 (Base) – Fifth westbound mainline lane extended to I-4 off-ramp. Three-lane exit to I-4 with a 2/2 split.
- Alternative 202B - Fifth westbound mainline lane extended to I-4 off-ramp. Two-lane exit to I-4 with a 2/1 split (existing).
- Alternative 203B - Fifth westbound mainline lane extended to I-4 off-ramp. Three-lane exit to I-4 with a 2/2 split, and Bumby Avenue on-ramp and Mills Avenue off-ramp switched.
- Alternative 203 - Fifth westbound mainline lane extended to I-4 off-ramp. Two-lane exit to I-4 with a 2/1 split (existing), one-lane exit to Rosalind Ave, and Bumby Ave on-Ramp and Mills Ave off-ramp switched.

The results of the traffic analysis indicated that Alternative 202 is the preferred configuration as it provides the most benefit. However, FDOT stated that an Interchange Modification Report (IMR) would be needed for proposed ramp improvements related to the I-4 interchange. CFX selected to exclude any improvements along the I-4 off-ramp and to proceed with Alternative 202B as the Preferred Alternative for this PD&E study. In the future, D5 may pursue an IMR for needed improvements to the I-4 interchange, and a three lane exit to I-4, as proposed under Alternative 202, could be implemented at that time. Even with maintaining a two-lane exit to I-4, travel speeds would increase by 40% when compared to the No-Build.

The traffic analysis demonstrated a need for a two-lane exit to Semoran Boulevard. A summary of all on- and off-ramps is provided below:

- I-4 off-ramp (Exit 10A) – maintain two-lane exit
- Rosalind Avenue off-ramp (Exit 11A) – maintain two-lane exit
- Mills Avenue off-ramp (Exit 11B) – maintain single-lane exit
- Bumby Avenue on-ramp – maintain single-lane on-ramp
- Semoran Boulevard off-ramp (Exit 14) – expand to two-lane exit

6.0 – Alternatives Considered

Segment from I-4 to Bumby Avenue

All alternatives within the segment from I-4 to Bumby Avenue included the addition of a fifth westbound lane by widening to the outside. Accommodating the additional lane includes widening of the overpass bridges and reconstruction of the toll gantry at the Bumby Avenue on-ramp. The following alternatives were considered:

- Provide a three-lane exit to I-4 with a 2/2 split between the I-4 EB and WB ramps. The I-4 EB ramp would merge back down to a single lane before crossing over South Street. This alternative was eliminated due to the requirement of preparing an IMR with approval from FDOT Central Office and the Federal Highway Administration (FHWA).
- Provide a three-lane exit to I-4 with a 2/1 split as provided today between the I-4 EB and WB ramps. This alternative was eliminated due to the requirement of preparing an IMR with approval from FDOT Central Office and the FHWA.
- For the segment from the bridge over Rosalind Avenue to the Rosalind Avenue off-ramp, widen to the outside to avoid impacting the existing median landscaping. This would involve right of way acquisition impacting the existing Orange County owned parking lot. This alternative was eliminated as Orange County indicated that there is a shortage of parking at this location and a reduction of spaces would be impactful.
- For the segment from the bridge over Rosalind Avenue to the Rosalind Avenue off-ramp, widen to the inside to avoid impacting Orange County owned property. This alternative was eliminated as it would impact the existing median landscaping which is an important feature for the City of Orlando.
- For the segment from the bridge over Rosalind Avenue to the Rosalind Avenue off-ramp, narrow the outside shoulder along the Rosalind Avenue off-ramp to 4-ft wide, reduce the outside mainline shoulder to 8-ft wide, and reduce the lane widths to 11.5-ft wide. This alternative avoids the Orange County owned property and only partially impacts the existing median landscaping. The existing median landscaping would be reduced from 10 ft to 6.5 ft. This alternative was selected as part of the Preferred Alternative.

Segment from Semoran Boulevard to Goldenrod Road

One Build Alternative was evaluated for the segment from Semoran Boulevard to Goldenrod Road. The Build Alternative includes adding a lane by widening to the outside. Accommodating the additional lane involves widening of the overpass bridge over Oxalis Avenue. This segment also includes a two-lane exit to Semoran Boulevard. No additional right of way is anticipated for improvements within this segment.

7.0 – Preferred Alternative

Concept plans for the Preferred Alternative are provided in **Appendix A**. Additional details are provided below.

Typical Sections

Typical sections are provided in **Appendix B**. For the segment parallel to the Rosalind Avenue off-ramp, the typical section includes an 8-ft wide outside shoulder, 11.5-ft wide travel lanes, and a 10-ft wide inside shoulder. The Rosalind Avenue off-ramp includes 11-ft wide lanes with 4-ft wide inside and outside shoulders. This typical section configuration avoids impacting the Orange County owned property and maintains a portion of the median landscaping barrier.

For the segment from Mills Avenue to Bumby Avenue, the typical section includes a 6-12 ft wide outside shoulder, a 12-ft wide auxiliary lane, five 12-ft wide travel lanes, and a 10-ft wide inside shoulder.

For the segment from Semoran Boulevard to Goldenrod Road, the typical section includes an 8-ft wide paved outside shoulder, a 14-ft wide outside lane, four 12-ft wide inside lanes, and a 10-ft wide outside shoulder. A 14-ft wide outside lane provides flexibility to repurpose the lanes to include Flex Lanes in the future.

Bridges and Structures

A summary of bridge widening needs is provided below. All bridge typical sections are provided in **Appendix C**.

SR 408 over Summerlin Avenue (Bridge No. 750242)

The westbound SR 408 bridge over Summerlin Avenue is being widened from four travel lanes to five and will provide 10'-0" inside and 8'-1/2" outside shoulders. Widening will occur to the outside which varies from 2'-8" to 3'-2". The existing inside barrier wall will be removed and a new wall will be reconstructed 4' to the inside. Only one superstructure design alternative is considered for the overall bridge length of 166 ft along the bridge centerline. The proposed widening can be accommodated utilizing prestressed Florida-I Beam girders.

SR 408 WB over Mills Avenue (Bridge No. 750116)

The westbound SR 408 bridge over Mills Avenue is being widened from five travel lanes to six and will provide 10'-0" inside and 12'-0" outside shoulders. Widening will occur to the outside which varies from 7'-4" to 9'-3". The existing inside barrier wall will be removed and a new wall will be reconstructed to the inside. Only one superstructure design alternative is considered for the overall bridge length of 203.4 ft along the bridge centerline. The proposed widening can be accommodated utilizing prestressed Florida-I Beam girders.

SR 408 over Bumby Avenue (Bridge No. 750244)

The westbound SR 408 bridge over Bumby Avenue is being widened from four travel lanes to five and will provide 20'-0" inside and 12'-0" outside shoulders. Widening will occur to the outside which varies from 3'-9" to 5'-5". Only one superstructure design alternative is considered for the overall bridge length of 191.5 ft along the bridge centerline. The proposed widening can be accommodated utilizing prestressed Florida-I Beam girders.

SR 408 WB over Yucatan Drive (Bridge No. 750126)

No widening of the existing westbound SR 408 bridge over Yucatan Drive is required.

SR 408 WB over Oxalis Drive (Bridge No. 750251)

The westbound SR 408 bridge over Oxalis Drive is being widened from four travel lanes to five and will provide 10'-1-5/8" inside and 12'-0" outside shoulders. Widening of the bridge by 15' – 10-7/8" will occur to the outside. Only one superstructure design alternative is considered for the overall bridge length of 126.0 ft along the bridge centerline. The proposed widening can be accommodated utilizing prestressed Florida-I Beam girders. The existing vertical clearance over Oxalis Drive is 15.4 feet. This will be further reduced with the widening.

SR 408 WB over Cosmos Drive (Bridge No. 750128)

No widening of the existing westbound SR 408 bridge over Cosmos Drive is required.

Right of Way and Relocations

No additional right of way is anticipated for the proposed improvements.

Horizontal and Vertical Geometry

The proposed project will maintain existing horizontal and vertical geometry.

Tolling Sites

There is a toll gantry on the Bumby Avenue on-ramp with two lanes—one for exact change and one transponder reader only. Reconstruction of the ramp toll gantry at Bumby Avenue is needed to accommodate proposed improvements and will result in only one lane with a transponder reader only.

There is a toll gantry on the Semoran Boulevard off-ramp with two lanes—one for exact change and one transponder reader only. Reconstruction of this ramp toll gantry may be needed to accommodate proposed improvements and should be verified during the design phase.

Bicycle and Pedestrian Accommodations

No changes to bicycle and pedestrian accommodations are proposed as part of this project.

Multimodal Accommodations

No changes to multimodal accommodations are proposed as part of this project.

Access Management

No change in access is proposed as part of this project.

Intersection and Interchange Concepts

- Rosalind Avenue off-ramp (Exit 11A): Maintain two-lane exit
- Mills Avenue off-ramp (Exit 11B): Maintain single-lane exit
- Bumby Avenue on-ramp – Maintain single-lane on-ramp
- Semoran Boulevard off-ramp (Exit 14) – expand to two-lane exit

Intelligent Transportation System (ITS)

To increase the safety of the traveling public, SR 408 proposed ITS infrastructure will include equipment consistent with CFX's overall ITS vision for the future. The safety aspect of ITS

equipment consists of its ability to monitor traffic and provide incident management and travel information to travelers on SR 408.

The Preferred Alternative may result in impacts to some of the existing ITS System along SR 408. ITS Improvements will be further evaluated during the design phase and may include the following ITS elements.

Wrong-Way Vehicle Detection and Warning Equipment (WWVD)

The wrong-way vehicle detection system includes vehicle detectors and wrong-way LED Rapid Flashing Beacon warning system that gives wrong-way drivers a visible real-time indication prior to entering the CFX roadway system. When activated, the wrong-way signs flash with high intensity LEDs. The wrong way driving system utilizes radar and an HD camera to detect, analyze and confirm oncoming or outgoing vehicles. When a wrong-way driving event occurs, the information collected sends an alert notification and event package containing a configurable sequence of images, video and other data to the Regional Transportation Management Center (RTMC) so that the RTMC can deploy the necessary safety protocol. The proposed system will monitor the SR 408 ramps 24 hours a day without interfering with other traffic detection systems.

All exit ramps within the project limits include existing wrong way driving systems. Verification of potential impacts is needed during the design phase. If necessary, WWVD improvements should be included.

Data Collection Sensor (DCS)

DCS's are used in travel time analysis by the detecting transponders located in the traveling vehicles. The DCS will be installed at the on/off-ramps and will collect accurate travel time information to be disseminated to the traveling public via existing DMS signs. Installing DCS at the on/off ramps is an effective way to control traffic congestion by analyzing and predicting traffic flow.

Power Distribution System and Fiber Connections:

For this study it was assumed one power service per HUB location will be needed. The future design firm shall be responsible for verifying the proposed locations and determining available power sources and voltages needed to operate all the proposed ITS equipment. Additionally, it will be necessary to coordinate with utility companies for the power connection. Disconnects, service meters and six-inch-thick maintenance pads are to be installed at all locations. The design team will have to design the connections between the existing fiber line to the proposed ITS elements.

Utilities

Data on existing utilities is provided within the **Existing Conditions** section of this report. Cost, scheduling, and any UAO dispositions and agreements pertaining to the potential relocation of any facilities will be further investigated as part of the design phase for this project.

Drainage and Stormwater Facilities

There are several existing stormwater management facilities (SMFs) servicing SR 408 between I-4 and Goldenrod Road. These SMFs have already been permitted through SJRWMD to provide treatment and attenuation for an ultimate 10-lane mainline condition. Although the SMFs are permitted for a 10-lane mainline, the proposed improvements also address capacity improvements along on-ramps, off-ramps, and auxiliary lanes, which requires additional widening to the outside. Analysis of the net additional proposed impervious area compared to the permitted 10-lane impervious area is evaluated to determine if any additional treatment and attenuation needs are required for the proposed improvements. Refer to **Figure 3** for locations of the additional and removed impervious areas that exceed the SR 408 10-lane mainline condition.

Proposed Basins

The proposed basin delineation along SR 408 is anticipated to match the permitted condition. The western segment of the project, from I-4 to Primrose Drive, is located within the City of Orlando's Southeast Lakes Basin, which is comprised of several lakes classified as closed basins. SMFs within this area are comprised of dry retention facilities. The eastern segment of the project, from the Lake Underhill Toll Plaza to Goldenrod Road is located within the headwaters of Little Econlockhatchee River tributaries. These SMFs are comprised of wet detention facilities and a dry detention infield area.

The City of Orlando has developed a watershed model for the closed basins under Southeast Lakes Basin (SJRWMD ERP 131052). This Southeast Lake Basin model is currently being revised to include subsequent projects that have been completed by the City throughout the watershed and the basin changes that resulted from the I-4 Ultimate project. SR 408 and its existing SMFs were modeled within this Southeast Lakes Basin, which can provide useful tailwater information, evaluate attenuation criteria, and analyze floodplain impacts.

Treatment Volume

Treatment volume provided within these existing SMFs are based on the net new impervious along SR 408 corridor. Dry retention SMFs located within the western segment of the project used 1.25-inch over the net new impervious from the 6-lane condition to the 10-lane condition plus 0.5-inch over the new project area, which included the net new impervious and the pond site. The wet detention SMFs located within the eastern segment of the project use the greater of 2.5-inches over the net new impervious.

Since these existing SMFs are permitted for the 10-lane mainline, only the net impervious area due to auxiliary lane and on/off-ramp improvements were evaluated. **Table 19** provides a summary of the change in impervious area of the auxiliary lanes and ramp improvements and the resulting additional treatment volume within each watershed following permitted criteria.

Figure 3: Additional Impervious Area Locations & Potential Encroachment into Floodplains

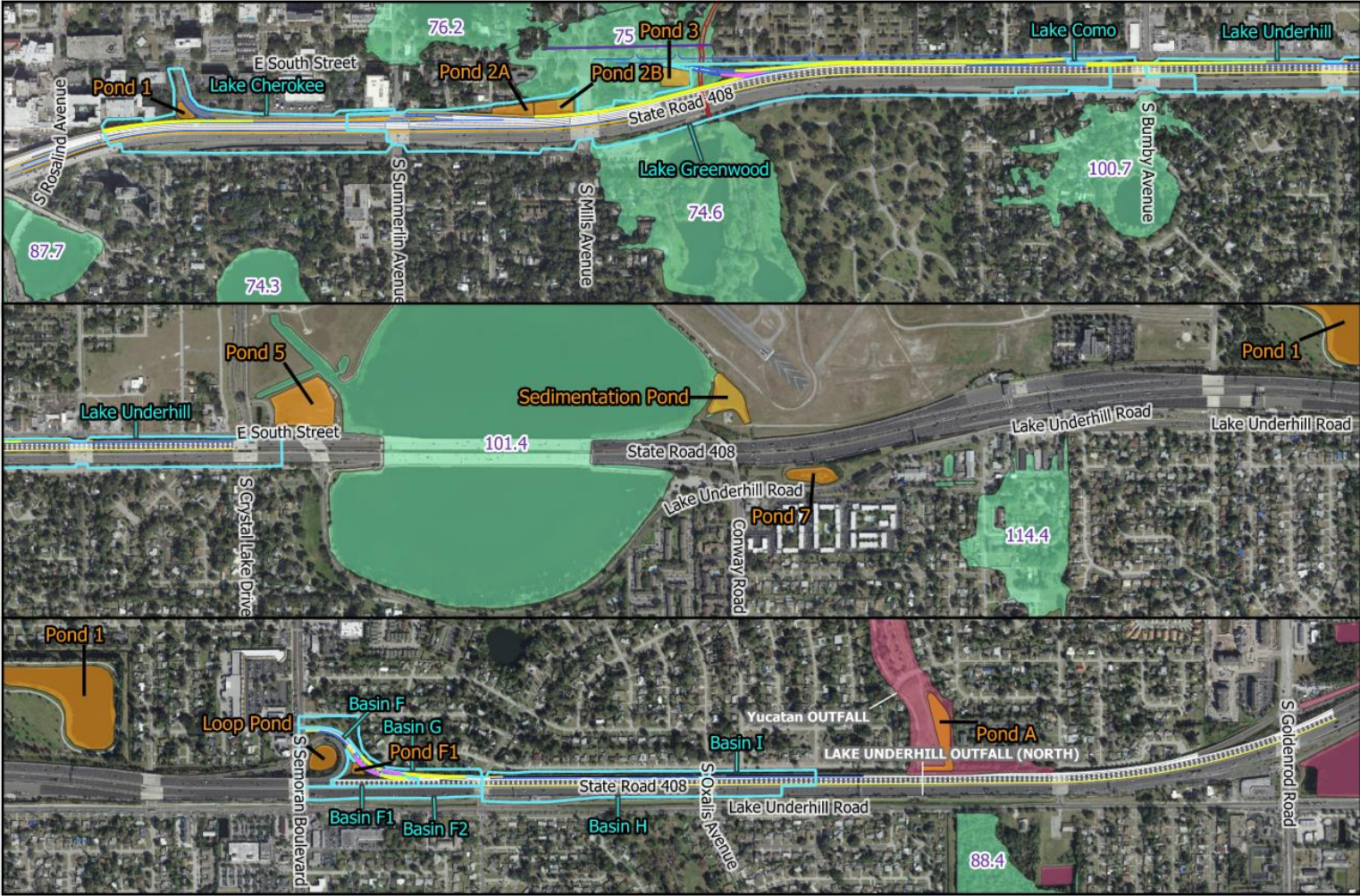

- Legend**
- Existing SR 408 Ponds
 - Basins
 - Additional Impervious Area
 - Removed Impervious Area
 - FEMA BFE
 - FEMA Zone AE
 - FEMA Zone A
 - Regulated FEMA Floodway

Table 19: Net Proposed Impervious

SR 408 Segment	Watershed	Added ⁽¹⁾ (ac)	Removed ⁽¹⁾ (ac)	Net Impervious Area ⁽¹⁾ (ac)	Additional Treatment Volume ⁽³⁾
Western Segment	Lake Cherokee	0.44	0	0.44	0.06
	Lake Greenwood	0.94	0.06	0.88	0.13
	Lake Como	0.2	0	0.2 ⁽²⁾	N/A
	Lake Underhill	0.2	0	0.2	0.03
Eastern Segment	Lake Barton	N/A – Outside Project Limits			
	Yucatan Outfall Canal	0.31	0.1	0.21	0.04

(1) Only includes areas at ramps and auxiliary lanes that are beyond the SR 408 10-lane mainline typical section.

(2) Permitted basin division rerouted 1.5-acres of impervious area away from Lake Como.

(3) Treatment volume calculations follow permitted treatment volume methodology for each SMF.

Each watershed, with the exception of Lake Como, has one or more existing SMF(s) to provide treatment. **Table 20** summarizes the available treatment volume, if any, within the existing SMFs. When these existing SMFs were permitted, a portion of the Lake Como basin was rerouted to Lake Greenwood to provide compensatory treatment for the Lake Como watershed.

Table 20 - Existing SMF Treatment Volume Capacity

Watershed	Existing SMF	Required Treatment Volume (ac-ft)	Provided Treatment Volume (ac-ft)	Excess Treatment Volume (ac-ft)	Excess per Watershed (ac-ft)
Lake Cherokee	Pond 1	0.36	0.44	0.08	0.08
Lake Greenwood	Pond 2A	0.59	0.59	0	1.58
	Pond 2B	0.53	0.55	0.02	
	Pond 3	0.54	1.57	1.03	
	Lake Greenwood	0	0.53	0.53	
Lake Como	<i>N/A – Permitted compensation provided within Lake Greenwood Watershed</i>				
Lake Underhill	Pond 5	2.19	4.87	2.68	2.68
Lake Barton	Pond 1	<i>Outside project limits</i>			
Yucatan Outfall Canal	Loop Pond	0.51	1.08	0.57	0.81
	Pond F1	0	0.24	0.24	
	Pond A	2.28	2.28	0	

As shown within **Tables 19** and **20**, the SMFs within each watershed provide more treatment volume than the net new impervious would require. Although there is a net of 0.2-acre of additional impervious within the Lake Como watershed, the permitted condition originally diverted 1.5-acres of impervious area from Lake Como. Therefore, the proposed additional impervious remains less than the original pre-development condition.

Attenuation

Attenuation requirements for a 10-lane condition have already been permitted within the existing SMFs along the corridor. The western segment of the project is located within several closed basins. These SMFs were sized to contain the increase in volume runoff for the 25-year/96-hour storm event, with the exception of Lake Greenwood and Lake Como. A basin diversion was used to reroute runoff away from Lake Como to Lake Greenwood, thus resulting in 2.6 ac-ft of runoff away from Lake Como. Lake Greenwood is the lowest lake in the surrounding area; therefore, attenuation was evaluated by analyzing the floodplain’s peak stage within Lake Greenwood by using the City of Orlando’s ICPR model.

For the closed basins, the NRCS CN runoff volume methodology was utilized with 13-inches rainfall. The approximate additional required runoff volume for the proposed followed this same methodology converting the land use from open space, good condition (CN of 39) to impervious (CN of 98). **Table 21** provides a summary of the anticipated additional runoff volume that may be required by the proposed improvements compared to the permitted excess attenuation volume provided within each watershed.

Possible control structure modification or SMF regrading may be required within the design phase to accommodate the change in runoff volume for the proposed improvements. The design team should coordinate with the City of Orlando to obtain the most recent Southeast Lakes Basin ICPR model to evaluate attenuation and floodplain within this segment of the project.

Table 21: Closed Basins Attenuation Volume

Watershed	Area (ac)	Permitted Weighted Curve Number	Proposed Weighted Curve Number	Additional Attenuation Volume (ac-ft)	Permitted Required Attenuation Volume (ac-ft)	Provided Attenuation Volume (ac-ft)	Excess Attenuation Volume (ac-ft)
Lake Cherokee	12.26	77.69	79.81	0.30	0.44	0.44	0.0
Lake Greenwood	33.01	82.26	83.83	0.59	<i>N/A – Evaluated floodplain peak stage within Lake Greenwood using ICPR</i>		
Lake Como	3.04	79.4	83.25	0.13	--	--	2.6 ⁽¹⁾
Lake Underhill	17.75	95.2	95.2	0 ⁽²⁾	4.80	4.87	0.07

(1) Permitted condition redirected 2.6 ac-ft away from Lake Como towards Lake Greenwood.

(2) Permitted with the presumption of SR 408 to be 100% Impervious

The eastern segment of the project is permitted as open basins to meet pre-post peak flowrate for the 25-year/24-hour storm event. The change in impervious area beyond the SR 408 10-lane condition occurs at the Semoran Boulevard interchange’s westbound off-ramp reconfiguration. This area is routed to Pond F (Loop) or Pond F1 (infield area) to receive attenuation. As shown in **Table 19**, there was very little net additional impervious area within this watershed, which is anticipated to have a marginal affect to the post peak flowrate. **Table 22** provides a summary of permitted pre-development vs. SR 408 10-lane mainline post-development. Possible control structure modification or SMF regrading may be required within the design phase to accommodate the change in peak flowrate for the proposed improvements.

Table 22: Open Basins Attenuation Peak Flowrate

Watershed	SMF	Permitted Pre-Dev Peak Flowrate (cfs)	Permitted Post-Dev Peak Flowrate (cfs)	Excess Peak Flowrate (cfs)
Yucatan Outfall Canal	Pond F (Loop)	109.6cfs	102.4 cfs	7.2 cfs
	Pond F1 (infield)			

Floodplain Analysis

SR 408 mainline is being widened within existing right of way, which is anticipated to not have an adverse effect on surrounding floodplains or regulated floodways, however, there is one location where widening to the outside to accommodate auxiliary lanes and ramps for operational improvements is located within a FEMA floodplain and over a regulated FEMA Floodway. This encroachment occurs within Lake Greenwood’s floodplain, between Mills Avenue and Bumby Avenue, within the City of Orlando’s Southeastern Lakes Basin. The City of Orlando is currently revising the existing conditions model for the Southeast Lakes Basin, which was originally used to evaluate peak stages of Lake Greenwood during the permitting of SR 408 Widening project for Contract 253A. Additionally, this encroachment is also to occur within the limits of Fern Creek’s regulated FEMA Floodway, which flows south under SR 408 into Lake Greenwood. This will require the design phase to obtain a FEMA No Rise Certification for these improvements. Refer to **Figure 3** for locations of the proposed widening beyond the currently permitted 10-lane SR 408 mainline and its potential impacts to the surrounding FEMA floodplains.

Noise Walls

Modification to existing walls and new noise walls are proposed in several locations as summarized in the **Traffic Noise Study Report** available under separate cover. Specific locations are illustrated in **Appendix A** and discussed below.

Noise wall construction is proposed on the westbound side, approximately from the east side of the bridge over Rosalind Avenue to the Rosalind Avenue ramp terminal, from Summerlin Avenue to Mills Avenue, and from the Mills Avenue off-ramp to east of Bumby Avenue.

From Semoran Boulevard to Goldenrod Road, noise wall construction is proposed from Semoran Boulevard to Yucatan Drive. The remainder of the segment includes existing noise walls. A re-evaluation of the Traffic Noise Study will be conducted as part of the design phase.

Lighting

A lighting analysis was performed in AGi32 software using the proposed typical sections along SR 408. A 5-lane section, 6-lane, and 7-lane section (exit lanes) were analyzed for proposed light pole spacing using a 241W Lumec Signify Large Road Focus cobra head luminaire. Based on CFX Design Guidelines and Lighting Standards, a 45’ mounting height and a 15’ bracket arm length were assumed for this analysis. FDOT lighting criteria for Limited Access Facilities from Table 231.2.1 of the Florida Design Manual (FDM) was used to set the parameters for the lighting analysis. AGi32 roadway optimizer results showed that a spacing of approximately 200’ between poles would be required to illuminate the corridor to FDOT standards. The 7-lane typical section with exit lanes may require supplemental lighting along the edge of the roadway to achieve uniform lighting levels. Upon review of the corridor, many existing light poles are currently installed behind guardrail or behind a wall section. Assuming that future conditions will

have similar accommodations, light poles should be placed as close to the roadway as possible while still meeting clear zone requirements. In summary, results of the initial lighting analysis show that light poles are needed every approximately 200' on each side of the roadway to achieve FDOT lighting criteria for Limited Access Facilities.

Design Variations and Exceptions

No design variations or exceptions are needed for this project.

Cost Estimates

The total estimated construction cost for the Preferred Alternative is \$61,123,062. A breakdown of costs is provided in **Appendix D**.

Appendix A – Concept Plans

11/10/2023 11:30:40 AM K:\ORL_IPTO\240260002_IBG-CFX_TWO_#2\12345678910\roadway\Plansheets\PLANRD01.dgn eric.benson

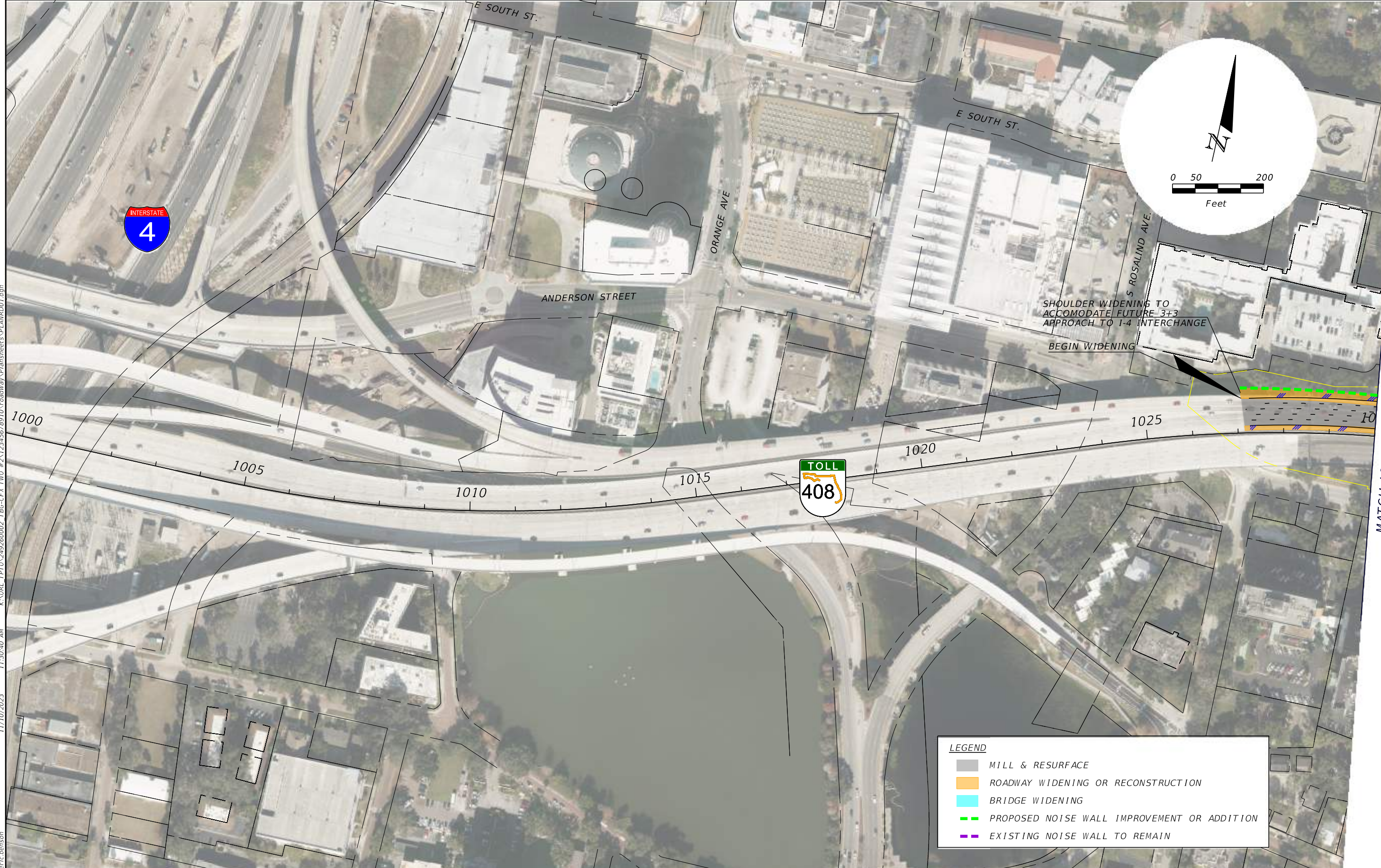

LEGEND	
	MILL & RESURFACE
	ROADWAY WIDENING OR RECONSTRUCTION
	BRIDGE WIDENING
	PROPOSED NOISE WALL IMPROVEMENT OR ADDITION
	EXISTING NOISE WALL TO REMAIN

REVISIONS		PREPARED BY	
DATE	DESCRIPTION	DATE	DESCRIPTION

PREPARED BY
KIMLEY-HORN AND ASSOCIATES INC.
 189 SOUTH ORANGE AVENUE, SUITE 1000
 ORLANDO, FLORIDA, 32801

SR 408 WIDENING FROM
 I-4 TO S GOLDENROD ROAD

ROAD NO.	PROJECT NO.
SR-408	408-175



CONCEPT PLANS

SHEET NO.
01

THE OFFICIAL RECORD OF THIS SHEET IS THE ELECTRONIC FILE DIGITALLY SIGNED AND SEALED UNDER RULE 61G15-23.004, F.A.C.

11/10/2023 11:30:54 AM K:\ORL_IPT\0240260002_TBG-CFX_TWB_#2\123456789\roadway\Plansheets\PLANRD02.dgn eric.benson

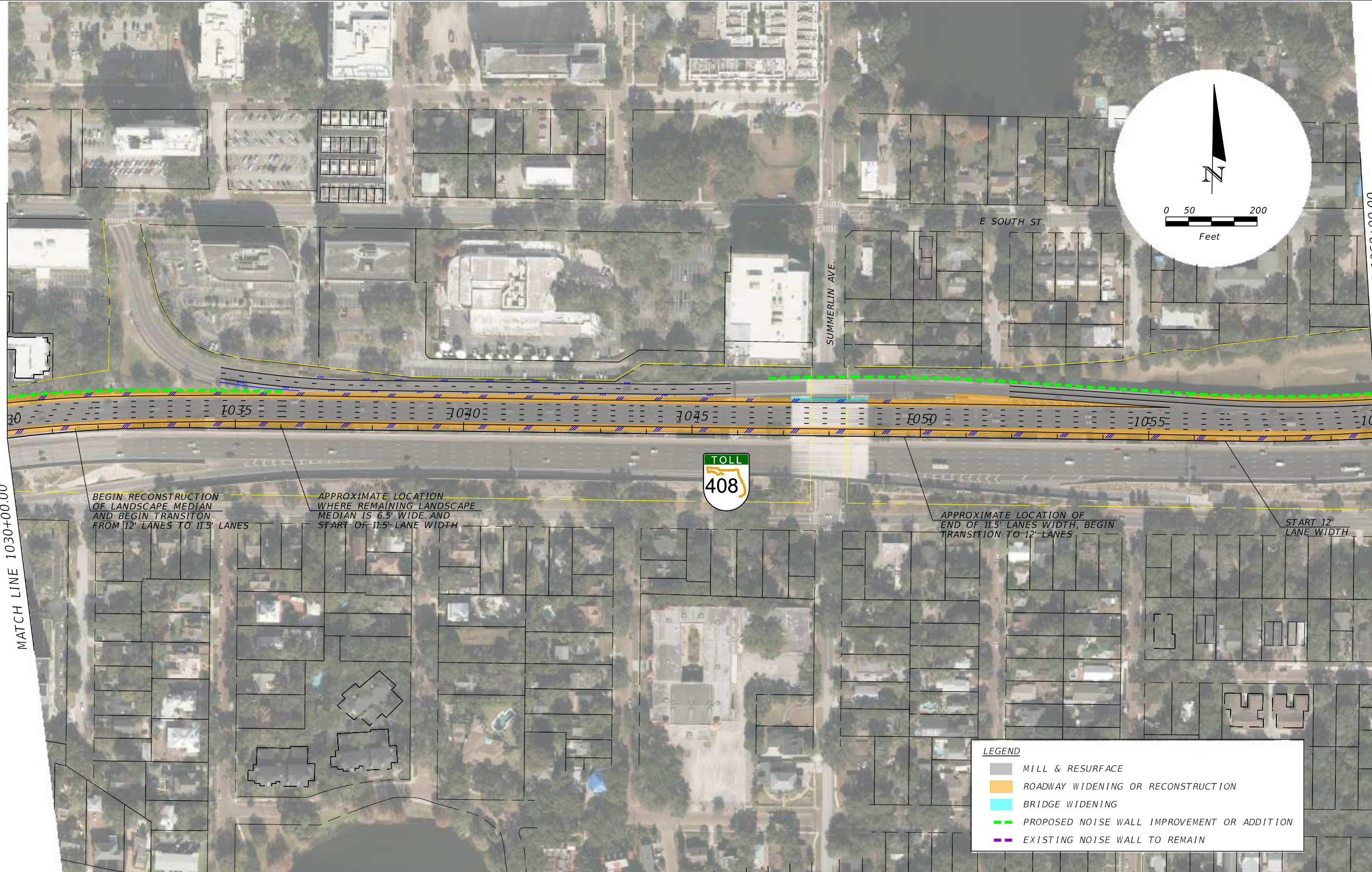

BEGIN RECONSTRUCTION OF LANDSCAPE MEDIAN AND BEGIN TRANSITION FROM 12' LANES TO 11.5' LANES

APPROXIMATE LOCATION WHERE REMAINING LANDSCAPE MEDIAN IS 6.5' WIDE AND START OF 11.5' LANE WIDTH

APPROXIMATE LOCATION OF END OF 11.5' LANES WIDTH, BEGIN TRANSITION TO 12' LANES

START 12' LANE WIDTH



LEGEND	
	MILL & RESURFACE
	ROADWAY WIDENING OR RECONSTRUCTION
	BRIDGE WIDENING
	PROPOSED NOISE WALL IMPROVEMENT OR ADDITION
	EXISTING NOISE WALL TO REMAIN

MATCH LINE 1030+00.00

MATCH LINE 1060+00.00

REVISIONS			
DATE	DESCRIPTION	DATE	DESCRIPTION

PREPARED BY
 KIMLEY-HORN AND ASSOCIATES INC.
 189 SOUTH ORANGE AVENUE, SUITE 1000
 ORLANDO, FLORIDA, 32801

SR 408 WIDENING FROM 1-4 TO 5 GOLDENROD ROAD	
ROAD NO.	PROJECT NO.
SR-408	408-175



CONCEPT PLANS

SHEET NO.

THE OFFICIAL RECORD OF THIS SHEET IS THE ELECTRONIC FILE DIGITALLY SIGNED AND SEALED UNDER RULE 61G15-23.004, F.A.C.

11/10/2023 11:31:03 AM K:\ORL_TPT0\249260002_TB6-CFX_TW0 #2\12345678910\roadway\Plansheets\PLANRD03.dgn

eric.henson

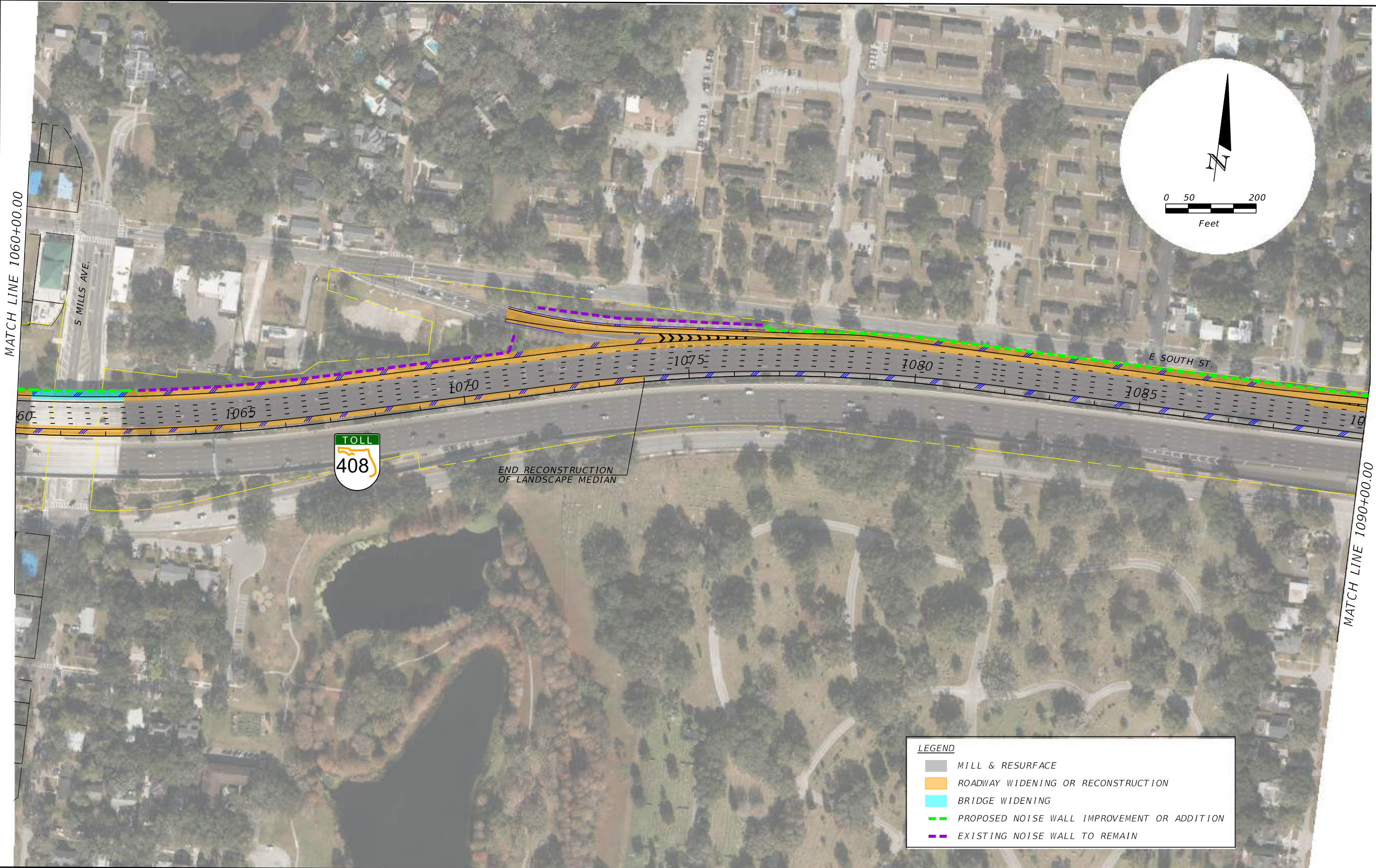

MATCH LINE 1060+00.00

MATCH LINE 1090+00.00

LEGEND	
	MILL & RESURFACE
	ROADWAY WIDENING OR RECONSTRUCTION
	BRIDGE WIDENING
	PROPOSED NOISE WALL IMPROVEMENT OR ADDITION
	EXISTING NOISE WALL TO REMAIN

REVISIONS			
DATE	DESCRIPTION	DATE	DESCRIPTION

PREPARED BY
 KIMLEY-HORN AND ASSOCIATES INC.
 189 SOUTH ORANGE AVENUE, SUITE 1000
 ORLANDO, FLORIDA, 32801

SR 408 WIDENING FROM I-4 TO S GOLDENROD ROAD	
ROAD NO.	PROJECT NO.
SR-408	408-175



CONCEPT PLANS

SHEET NO.
03

THE OFFICIAL RECORD OF THIS SHEET IS THE ELECTRONIC FILE DIGITALLY SIGNED AND SEALED UNDER RULE 61G15-23.004, F.A.C.

11/10/2023 11:31:13 AM K:\ORL_TPT\0\249260002_TBG-CFX_TWO_#2\123456789\roadway\Plansheets\PLANRD04.dgn eric.jenison

MATCH LINE 1090+00.00

MATCH LINE 1120+00.00

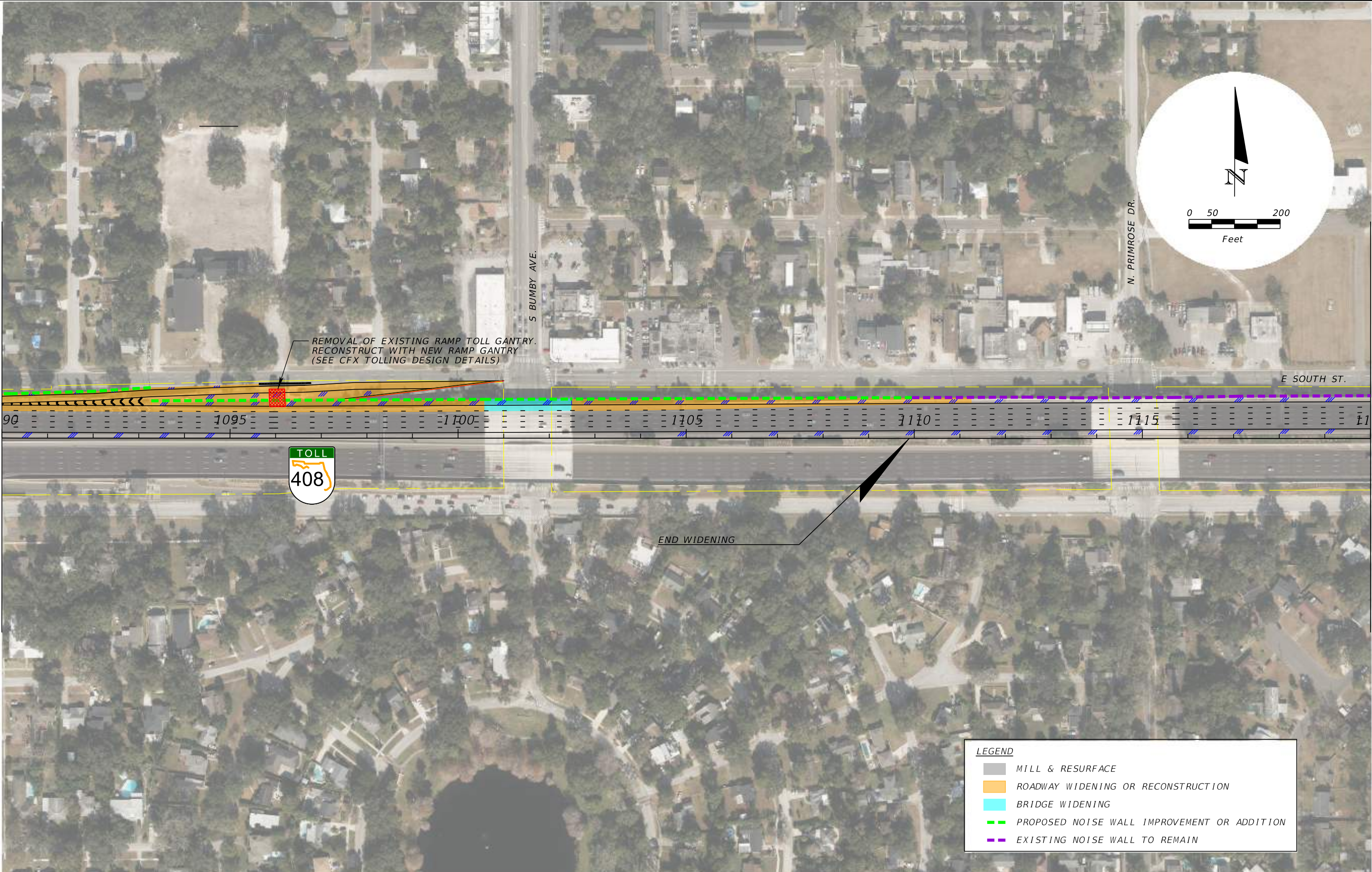

REMOVAL OF EXISTING RAMP TOLL GANTRY.
RECONSTRUCT WITH NEW RAMP GANTRY
(SEE CFX TOLLING DESIGN DETAILS)

END WIDENING

LEGEND	
	MILL & RESURFACE
	ROADWAY WIDENING OR RECONSTRUCTION
	BRIDGE WIDENING
	PROPOSED NOISE WALL IMPROVEMENT OR ADDITION
	EXISTING NOISE WALL TO REMAIN

REVISIONS			
DATE	DESCRIPTION	DATE	DESCRIPTION

PREPARED BY
KIMLEY-HORN AND ASSOCIATES INC.
189 SOUTH ORANGE AVENUE, SUITE 1000
ORLANDO, FLORIDA, 32801

SR 408 WIDENING FROM I-4 TO S GOLDENROD ROAD	
ROAD NO.	PROJECT NO.
SR-408	408-175



CONCEPT PLANS

SHEET NO.
04

THE OFFICIAL RECORD OF THIS SHEET IS THE ELECTRONIC FILE DIGITALLY SIGNED AND SEALED UNDER RULE 61G15-23.004, F.A.C.

11/10/2023 11:31:22 AM K:\ORL_TPTD\249260002_TB6-CFA_TW0 #2\12345678910\roadway\plansheets\PLANRD05.dgn eric.benson

MATCH LINE 1120+00.00



LEGEND	
	MILL & RESURFACE
	ROADWAY WIDENING OR RECONSTRUCTION
	BRIDGE WIDENING
	PROPOSED NOISE WALL IMPROVEMENT OR ADDITION
	EXISTING NOISE WALL TO REMAIN

REVISIONS				PREPARED BY	SR 408 WIDENING FROM I-4 TO S GOLDENROD ROAD	CENTRAL FLORIDA EXPRESSWAY AUTHORITY	CONCEPT PLANS	SHEET NO.
DATE	DESCRIPTION	DATE	DESCRIPTION					
				KIMLEY-HORN AND ASSOCIATES INC. 189 SOUTH ORANGE AVENUE, SUITE 1000 ORLANDO, FLORIDA, 32801	ROAD NO.	PROJECT NO.		05
					SR-408	408-175		

THE OFFICIAL RECORD OF THIS SHEET IS THE ELECTRONIC FILE DIGITALLY SIGNED AND SEALED UNDER RULE 61G15-23.004, F.A.C.

11/10/2023 11:31:32 AM K:\ORL_IPTO\240260002_IBG-CFX_TWO_#2\123456789\roadway\Plansheets\PLANRD09.dgn eric.benson

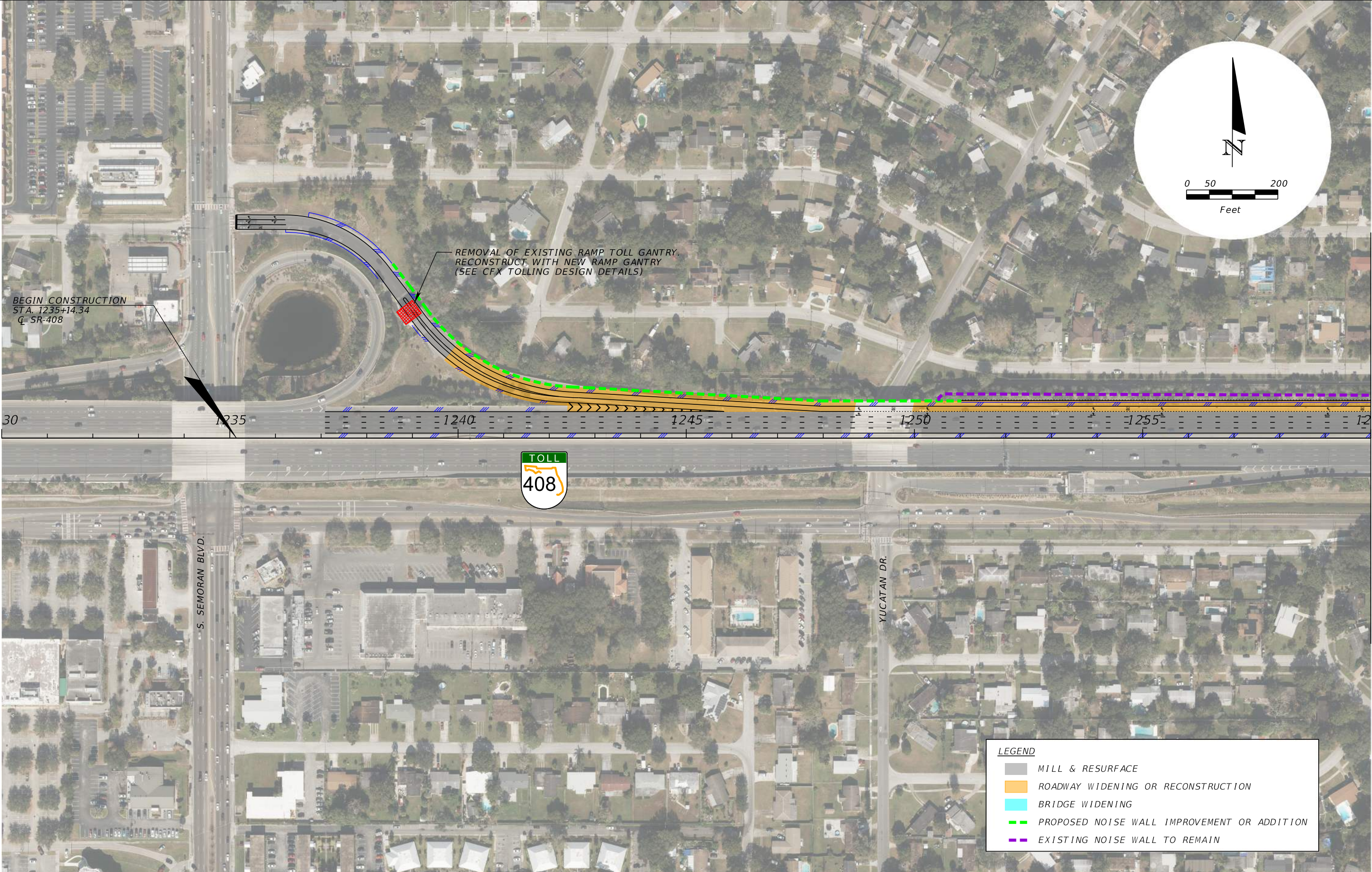

BEGIN CONSTRUCTION
STA. 1235+14.34
Q-SR-408

REMOVAL OF EXISTING RAMP TOLL GANTRY.
RECONSTRUCT WITH NEW RAMP GANTRY
(SEE CFX TOLLING DESIGN DETAILS)

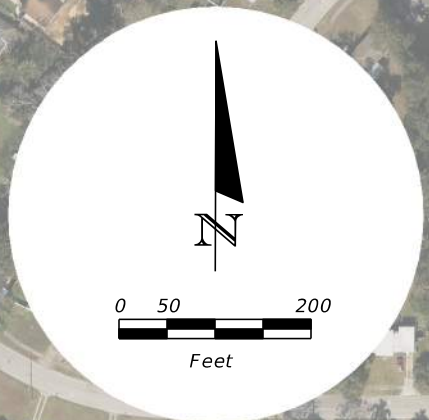

LEGEND	
	MILL & RESURFACE
	ROADWAY WIDENING OR RECONSTRUCTION
	BRIDGE WIDENING
	PROPOSED NOISE WALL IMPROVEMENT OR ADDITION
	EXISTING NOISE WALL TO REMAIN

REVISIONS			
DATE	DESCRIPTION	DATE	DESCRIPTION

PREPARED BY
KIMLEY-HORN AND ASSOCIATES INC.
189 SOUTH ORANGE AVENUE, SUITE 1000
ORLANDO, FLORIDA, 32801

SR 408 WIDENING FROM
1-4 TO 5 GOLDENROD ROAD

ROAD NO.	PROJECT NO.
SR-408	408-175



CONCEPT PLANS

SHEET NO.
09

MATCH LINE 1260+00.00 THE OFFICIAL RECORD OF THIS SHEET IS THE ELECTRONIC FILE DIGITALLY SIGNED AND SEALED UNDER RULE 61G15-23.004, F.A.C.

11/10/2023 11:33:15 AM K:\ORL_IPT\0\240260002_IBG-CFX_TWO_#2\123456789\roadway\Plansheets\PLANRD010.dgn eric.benson

MATCH LINE 1260+00.00

MATCH LINE 1290+00.00

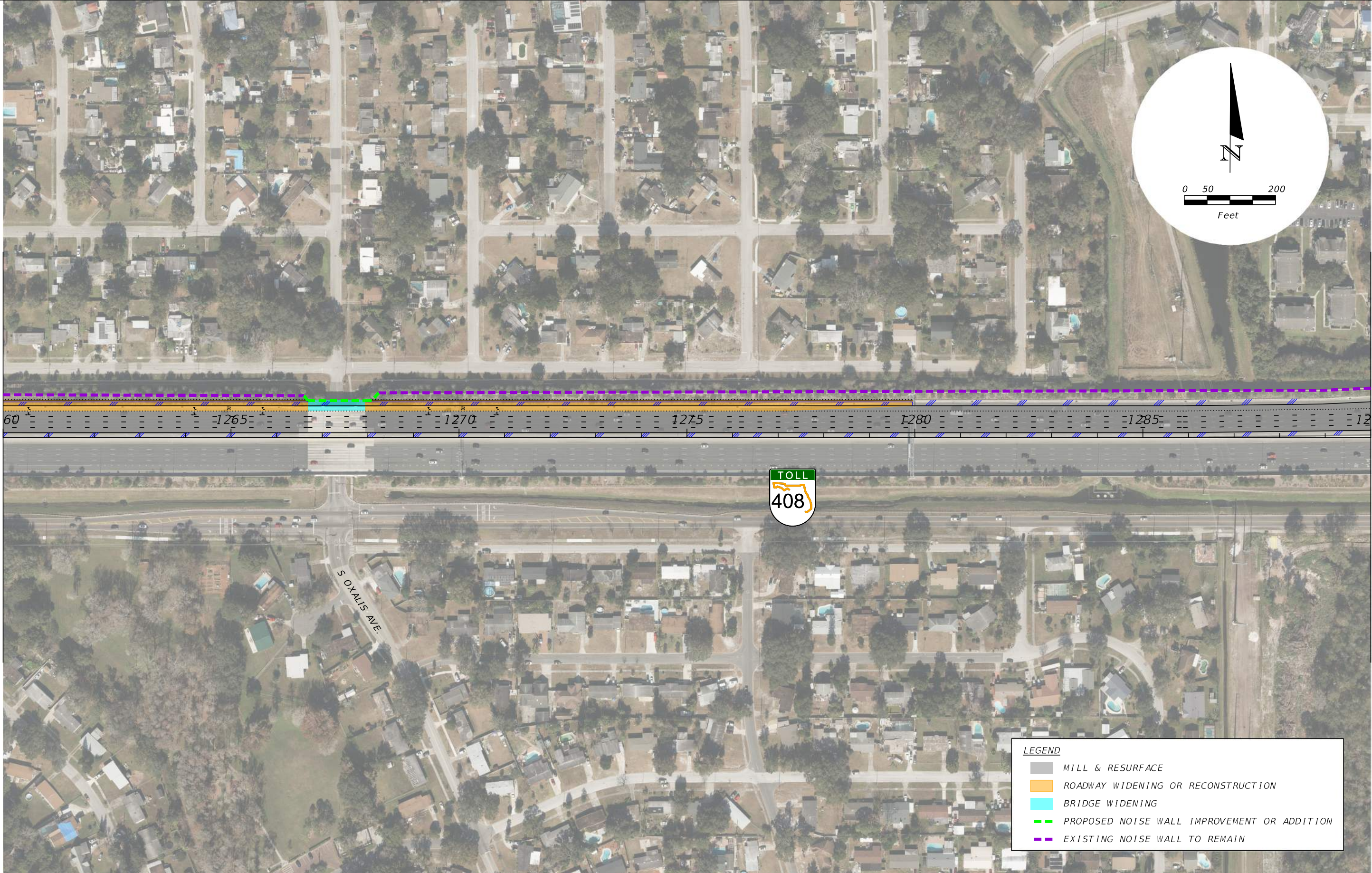

REVISIONS			
DATE	DESCRIPTION	DATE	DESCRIPTION

PREPARED BY
 KIMLEY-HORN AND ASSOCIATES INC.
 189 SOUTH ORANGE AVENUE, SUITE 1000
 ORLANDO, FLORIDA, 32801

SR 408 WIDENING FROM
 I-4 TO S GOLDENROD ROAD

ROAD NO.	PROJECT NO.
SR-408	408-175



CONCEPT PLANS

SHEET NO.
 010

THE OFFICIAL RECORD OF THIS SHEET IS THE ELECTRONIC FILE DIGITALLY SIGNED AND SEALED UNDER RULE 61G15-23.004, F.A.C.

11/10/2023 11:34:47 AM K:\ORL_IPTO\240260002_IBG-CFX_TWO_#2\12345678910\roadway\Plansheets\PLANRD011.dgn eric.benson

MATCH LINE 1290+00.00



LEGEND

- MILL & RESURFACE
- ROADWAY WIDENING OR RECONSTRUCTION
- BRIDGE WIDENING
- PROPOSED NOISE WALL IMPROVEMENT OR ADDITION
- EXISTING NOISE WALL TO REMAIN

REVISIONS		PREPARED BY	
DATE	DESCRIPTION	DATE	DESCRIPTION

PREPARED BY
KIMLEY-HORN AND ASSOCIATES INC.
 189 SOUTH ORANGE AVENUE, SUITE 1000
 ORLANDO, FLORIDA, 32801

SR 408 WIDENING FROM 1-4 TO 5 GOLDENROD ROAD	
ROAD NO.	PROJECT NO.
SR-408	408-175



CONCEPT PLANS

SHEET NO.
011

THE OFFICIAL RECORD OF THIS SHEET IS THE ELECTRONIC FILE DIGITALLY SIGNED AND SEALED UNDER RULE 61G15-23.004, F.A.C.

Appendix B – Roadway Typical Sections

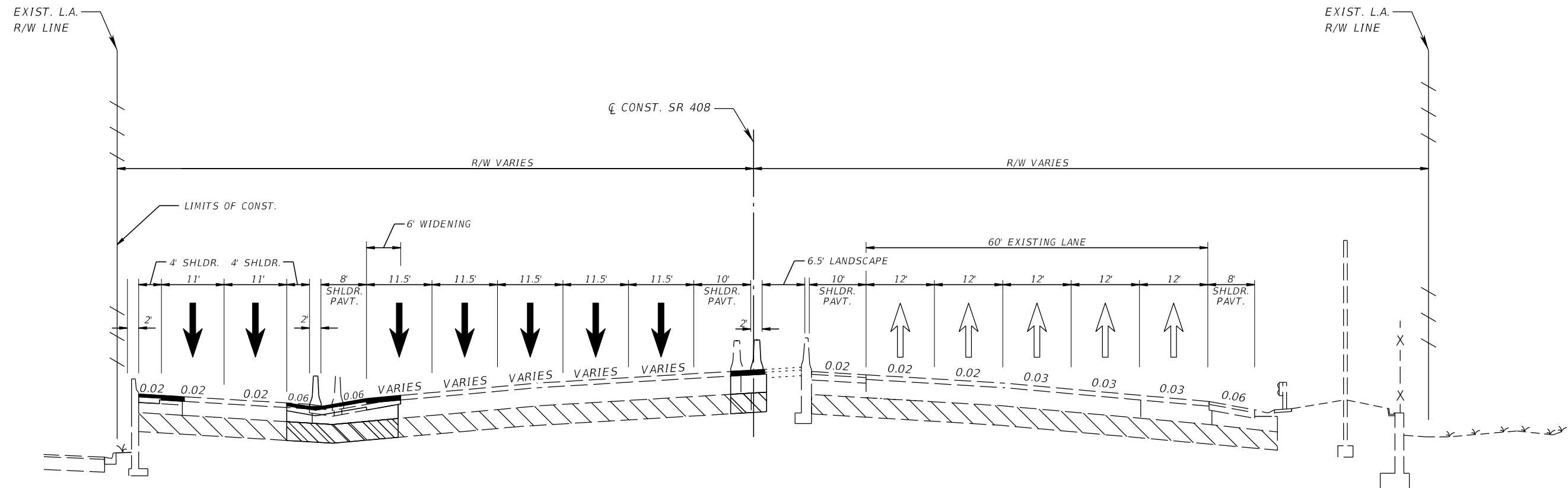

TYPICAL SECTION
SR 408
SEGMENT PARALLEL TO ROSALIND AVE EXIT

REVISIONS				PREPARED BY	SR 408 WIDENING FROM I-4 TO GOLDENROD ROAD	CENTRAL FLORIDA EXPRESSWAY AUTHORITY	TYPICAL SECTION (01)	SHEET NO.
DATE	DESCRIPTION	DATE	DESCRIPTION					1
				KIMLEY HORN AND ASSOCIATES INC. 189 SOUTH ORANGE AVENUE, SUITE 1000 ORLANDO, FLORIDA, 32801	ROAD NO. SR-408	PROJECT NO. 408-175		

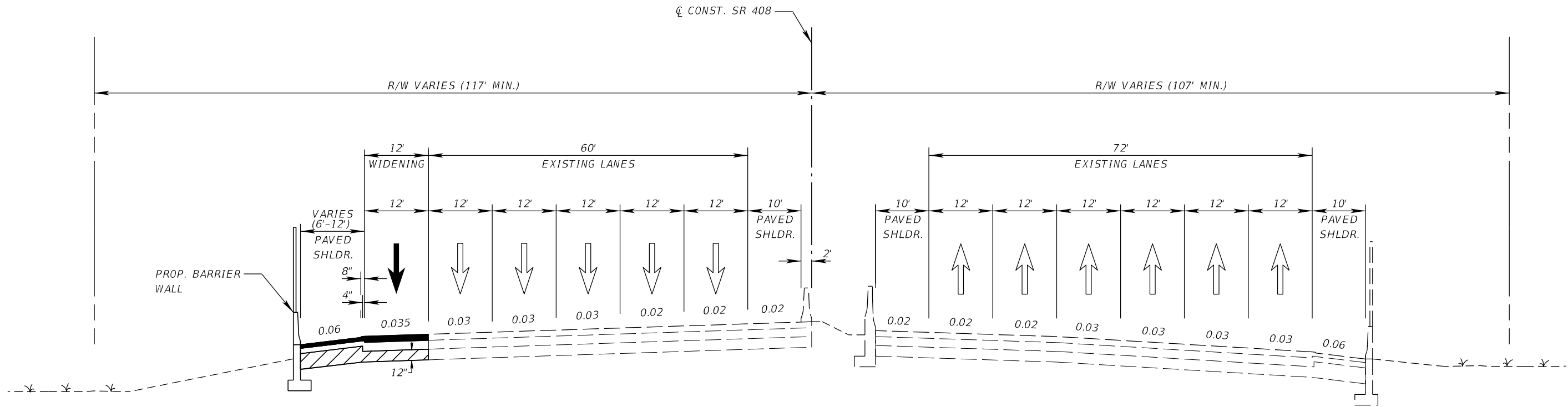

TYPICAL SECTION
 SR 408
 MILLS AVE TO BUMBY AVE

REVISIONS				PREPARED BY	SR 408 WIDENING FROM I-4 TO GOLDENROD ROAD	CENTRAL FLORIDA EXPRESSWAY AUTHORITY	TYPICAL SECTION (02)	SHEET NO.
DATE	DESCRIPTION	DATE	DESCRIPTION					2
				KIMLEY HORN AND ASSOCIATES INC. 189 SOUTH ORANGE AVENUE, SUITE 1000 ORLANDO, FLORIDA, 32801	ROAD NO. SR-408	PROJECT NO. 408-175		

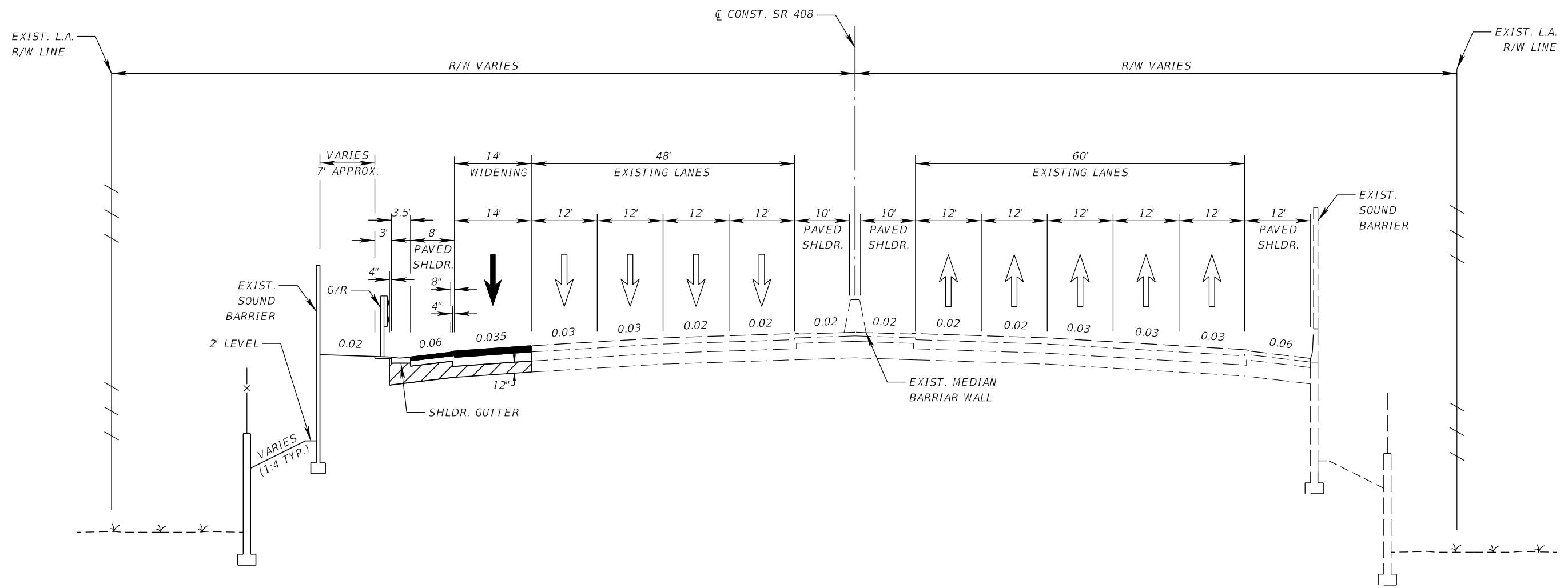

TYPICAL SECTION
SR 408
SEMORAN BLVD TO GOLDENROD ROAD

REVISIONS				PREPARED BY	SR 408 WIDENING FROM I-4 TO GOLDENROD ROAD	CENTRAL FLORIDA EXPRESSWAY AUTHORITY	TYPICAL SECTION (03)	SHEET NO.			
DATE	DESCRIPTION	DATE	DESCRIPTION					3			
				KIMLEY HORN AND ASSOCIATES INC. 189 SOUTH ORANGE AVENUE, SUITE 1000 ORLANDO, FLORIDA, 32801	<table border="1" style="width: 100%; border-collapse: collapse;"> <tr> <th style="text-align: center;">ROAD NO.</th> <th style="text-align: center;">PROJECT NO.</th> </tr> <tr> <td style="text-align: center;">SR-408</td> <td style="text-align: center;">408-175</td> </tr> </table>	ROAD NO.	PROJECT NO.	SR-408	408-175		
ROAD NO.	PROJECT NO.										
SR-408	408-175										

Appendix C – Bridge Typical Sections

K:\ORL_IPT\0240260002_IBG-CFY_TWO_#2\12345678910\STRUCT\TYPSTR_SUMMERLIN.dgn 6:12:43 PM 11/7/2023 NoJan.Villatoro

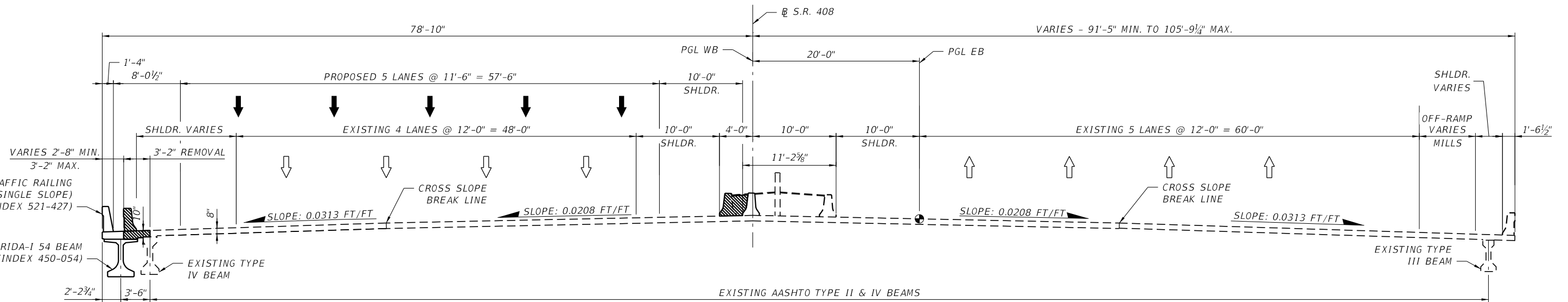

- LEGEND:**
- EXISTING BRIDGE TO BE REMOVED
 - EXISTING STRUCTURE
 - PROPOSED DIRECTION OF TRAVEL
 - EXISTING DIRECTION OF TRAVEL

BRIDGE NO. 750242

REVISIONS				PREPARED BY	SR 408 WIDENING FROM 1-4 TO 5 GOLDENROD ROAD		CENTRAL FLORIDA EXPRESSWAY AUTHORITY	<i>TYPICAL SECTION</i>	SHEET NO.
DATE	DESCRIPTION	DATE	DESCRIPTION		ROAD NO.	PROJECT NO.			1
				KIMLEY-HORN AND ASSOCIATES INC. 189 SOUTH ORANGE AVENUE, SUITE 1000 ORLANDO, FLORIDA, 32801	SR-408	408-175	CENTRAL FLORIDA EXPRESSWAY AUTHORITY	<i>TYPICAL SECTION</i>	1

THE OFFICIAL RECORD OF THIS SHEET IS THE ELECTRONIC FILE DIGITALLY SIGNED AND SEALED UNDER RULE 61G15-23.004, F.A.C.

K:\ORL_TPT0\249260002_TBG-CFX_TMO_#2\12345678910_Struct\TYPSTR_MILLS.dgn 6:14:37 PM 11/7/2023 NoAm.Vilatoro

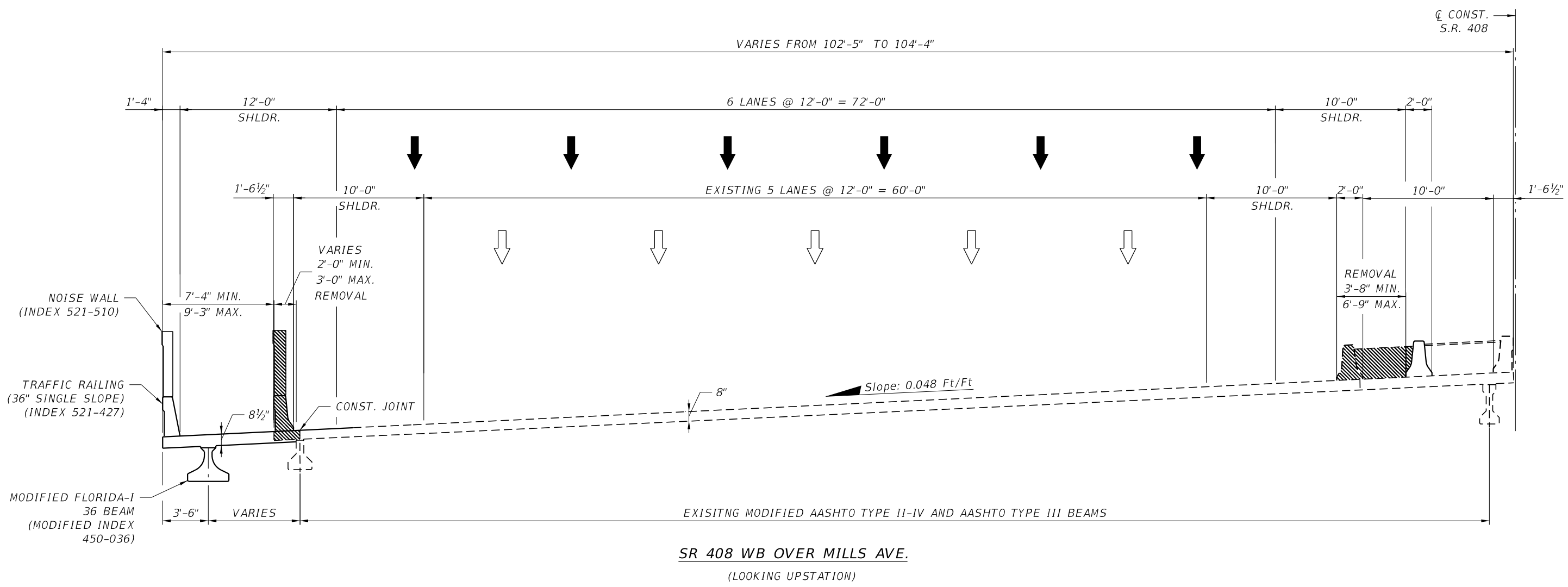

- LEGEND:**
- EXISTING BRIDGE TO BE REMOVED
 - EXISTING STRUCTURE
 - PROPOSED DIRECTION OF TRAVEL
 - EXISTING DIRECTION OF TRAVEL

BRIDGE NO. 750116

REVISIONS				PREPARED BY	SR 408 WIDENING FROM 1-4 TO 5 GOLDENROD ROAD		<h2 style="margin: 0;">TYPICAL SECTION</h2>	SHEET NO.				
DATE	DESCRIPTION	DATE	DESCRIPTION					2				
				KIMLEY-HORN AND ASSOCIATES INC. 189 SOUTH ORANGE AVENUE, SUITE 1000 ORLANDO, FLORIDA, 32801	<table border="1" style="width: 100%; border-collapse: collapse;"> <tr> <th style="width: 50%;">ROAD NO.</th> <th style="width: 50%;">PROJECT NO.</th> </tr> <tr> <td style="text-align: center;">SR-408</td> <td style="text-align: center;">408-175</td> </tr> </table>	ROAD NO.	PROJECT NO.	SR-408	408-175		<h2 style="margin: 0;">TYPICAL SECTION</h2>	2
ROAD NO.	PROJECT NO.											
SR-408	408-175											

THE OFFICIAL RECORD OF THIS SHEET IS THE ELECTRONIC FILE DIGITALLY SIGNED AND SEALED UNDER RULE 61G15-23.004, F.A.C.

11/10/2023 12:09:56 PM K:\ORL\TPT0\249260002_TBG-CFX_TWO_#2\1.2345678910\STRUCT\TYPSTR_BUMBY.dgn

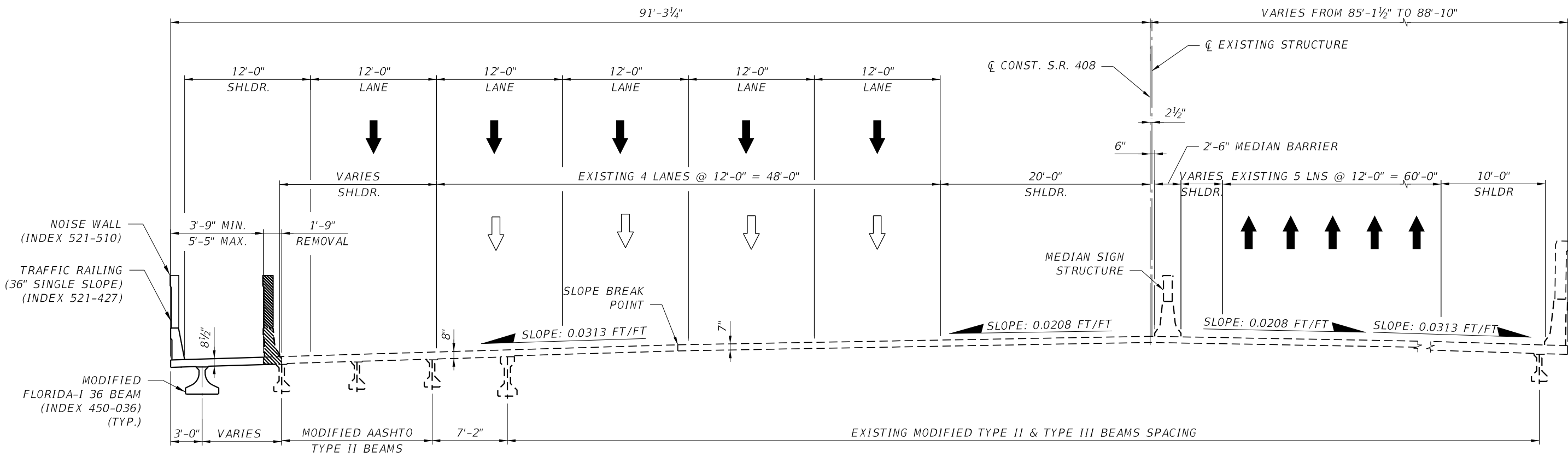

SR 408 OVER BUMBY DRIVE
(LOOKING UPSTATION)

- LEGEND:**
- EXISTING BRIDGE TO BE REMOVED
 - EXISTING STRUCTURE
 - PROPOSED DIRECTION OF TRAVEL
 - EXISTING DIRECTION OF TRAVEL

BRIDGE NO. 750244

REVISIONS			
DATE	DESCRIPTION	DATE	DESCRIPTION

PREPARED BY
KIMLEY-HORN AND ASSOCIATES INC.
189 SOUTH ORANGE AVENUE, SUITE 1000
ORLANDO, FLORIDA, 32801

SR 408 WIDENING FROM I-4 TO 5 GOLDENROD ROAD	
ROAD NO. SR-408	PROJECT NO. 408-175



TYPICAL SECTION

SHEET
NO.
3

THE OFFICIAL RECORD OF THIS SHEET IS THE ELECTRONIC FILE DIGITALLY SIGNED AND SEALED UNDER RULE 61G15-23.004, F.A.C.

11/10/2023 10:19:58 AM K:\ORL_IPT\0240260002_TBG-CFY_TWO #2\12345678910\STRUCT\TYPSTR_OXALIS.dgn

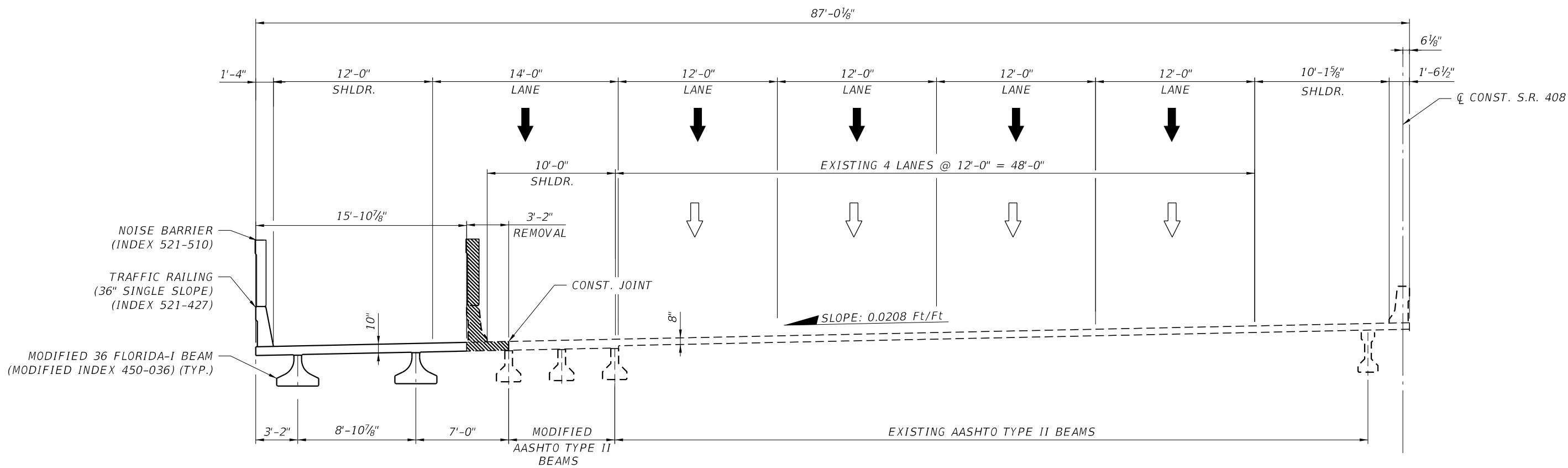

SR 408 WB OVER OXALIS DRIVE
 (LOOKING UPSTATION)

- LEGEND:**
- EXISTING BRIDGE TO BE REMOVED
 - EXISTING STRUCTURE
 - PROPOSED DIRECTION OF TRAVEL
 - EXISTING DIRECTION OF TRAVEL

BRIDGE NO. 750251

REVISIONS			
DATE	DESCRIPTION	DATE	DESCRIPTION

PREPARED BY
 KIMLEY-HORN AND ASSOCIATES INC.
 189 SOUTH ORANGE AVENUE, SUITE 1000
 ORLANDO, FLORIDA, 32801

SR 408 WIDENING FROM I-4 TO S GOLDENROD ROAD	
ROAD NO.	PROJECT NO.
SR-408	408-175



TYPICAL SECTION

SHEET NO.
4

THE OFFICIAL RECORD OF THIS SHEET IS THE ELECTRONIC FILE DIGITALLY SIGNED AND SEALED UNDER RULE 61G15-23.004, F.A.C.

Appendix D – Cost Estimates

